



# INSTALLATION & SERVICING

**LOGIC SYSTEM<sup>2</sup>**  
**S15 S18 S24 S30**

When replacing any part on this appliance, use only spare parts that you can be assured conform to the safety and performance specification that we require. Do not use reconditioned or copy parts that have not been clearly authorised by Ideal Heating.

For the very latest copy of literature for specification and maintenance practices visit our website [idealheating.com](http://idealheating.com) where you can download the relevant information in PDF format.



## ERP DATA

|   | SYMBOL      | UNITS        | 15 kW  | 18 kW | 24 kW | 30 kW |    |
|---|-------------|--------------|--------|-------|-------|-------|----|
| Condensing Boiler                               | n/a         | n/a          | yes    | yes   | yes   | yes   |    |
| Low Temperature Boiler                          | n/a         | n/a          | no     | no    | no    | no    |    |
| B1 Boiler                                       | n/a         | n/a          | no     | no    | no    | no    |    |
| Cogeneration Space Heater                       | n/a         | n/a          | no     | no    | no    | no    |    |
| Equipped with a Supplementary Heater            | n/a         | n/a          | no     | no    | no    | no    |    |
| Combination Heater                              | n/a         | n/a          | no     | no    | no    | no    |    |
| <b>Nominal Heat Output for Space Heating</b>    |             |              |        |       |       |       |    |
| Full Load                                       | P4          | kW           | 15.1   | 18.1  | 24.3  | 30.3  |    |
| Part Load                                       | P1          | kW           | 4.9    | 5.9   | 8.0   | 9.9   |    |
| <b>Auxiliary Electricity Consumption</b>        |             |              |        |       |       |       |    |
| Full Load                                       | elmax       | kW           | 0.022  | 0.025 | 0.046 | 0.050 |    |
| Part Load                                       | elmin       | kW           | 0.011  | 0.003 | 0.013 | 0.012 |    |
| Standby   | PSB         | kW           | 0.003  | 0.002 | 0.002 | 0.002 |    |
| <b>Seasonal Space Heating Energy Efficiency</b> |             |              |        |       |       |       |    |
| Full Load                                       | $\eta_4$    | %            | 90.0   | 90.0  | 90.0  | 89.6  |    |
| Part Load                                       | $\eta_1$    | %            | 97.8   | 98.5  | 98.6  | 98.2  |    |
| Standby Loss                                    | Pstby       | kW           | 0.05   | 0.05  | 0.05  | 0.05  |    |
| Ignition  | Pign        | kW           | 0      | 0     | 0     | 0     |    |
| <b>Emissions</b>                                |             |              |        |       |       |       |    |
|   | NOx (Gross) | NOx, pond Hs | mg/kWh | 21    | 24    | 28    | 26 |
| Annual Energy Consumption                       |             | QHE          | GJ     | 47    | 56    | 75    | 93 |
| Sound Power Level, Indoors                      |             | LWA          | dB     | 42    | 44    | 50    | 50 |

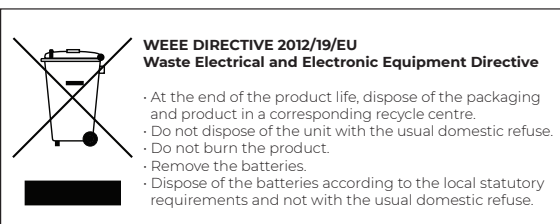

The code of practice for the installation, commissioning & servicing of central heating systems

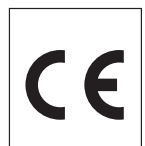

# PRODUCT FICHE

## LOGIC SYSTEM<sup>2</sup> S BOILER Ideal Heating ERP DATA

|  | SYMBOL   | UNITS | MODEL |       |       |       |
|--|----------|-------|-------|-------|-------|-------|
|  |          |       | 15 kW | 18 kW | 24 kW | 30 kW |
| Condensing boiler                        |          |       | Yes   |       |       |       |
| Seasonal Space heating efficiency class  |          |       | A     |       |       |       |
| Rated heat output                        |          | kW    | 15    | 18    | 24    | 30    |
| Seasonal space heating energy efficiency | $\eta_s$ | %     | 93*   | 93*   | 94*   | 93*   |
| Annual energy consumption                | $Q_{HE}$ | GJ    | 47    | 56    | 75    | 93    |
| Sound power level, indoors               | $L_{WA}$ | dB    | 42    | 44    | 50    | 50    |

|  |                 |                  |                 |                |                 |                  |                   |                                   |
|--|-----------------|------------------|-----------------|----------------|-----------------|------------------|-------------------|-----------------------------------|
| <b>Seasonal Space Heating Energy Efficiency of the Boiler</b>  |                 |                  |                 |                |                 |                  |                   | <b>94%</b> <sup>+%</sup> <b>A</b> |
| <b>Temperature control (from fiche of temperature control)</b> |                 |                  |                 |                |                 |                  |                   | % <b>B</b>                        |
| <i>Class I</i>   | <i>Class II</i> | <i>Class III</i> | <i>Class IV</i> | <i>Class V</i> | <i>Class VI</i> | <i>Class VII</i> | <i>Class VIII</i> |                                   |
| 1%   | 2%              | 1.5%             | 2%              | 3%             | 4%              | 3.5%             | 5%                |                                   |

### Solar Contribution (from fiche of solar device)

Collector Size  
(in m<sup>2</sup>)

Tank Volume  
(in m<sup>3</sup>)

Collector  
Efficiency  
(in %)

Tank rating  
A\* = 0.95  
A = 0.91  
B = 0.86  
C = 0.83  
D-G = 0.81

= ('III' x  + 'IV' x ) x 0.9 x (  / 100 x  ) =  % **C**

Seasonal Space Heating Energy Efficiency of Package

**TOTAL: A+B+C=**

 %

### Seasonal Space Heating Energy Efficiency Class of Package

|                          |                          |                          |                          |                          |                          |                          |                          |                          |                          |
|--------------------------|--------------------------|--------------------------|--------------------------|--------------------------|--------------------------|--------------------------|--------------------------|--------------------------|--------------------------|
| <input type="checkbox"/> | <input type="checkbox"/> | <input type="checkbox"/> | <input type="checkbox"/> | <input type="checkbox"/> | <input type="checkbox"/> | <input type="checkbox"/> | <input type="checkbox"/> | <input type="checkbox"/> | <input type="checkbox"/> |
| <b>G</b>                 | <b>F</b>                 | <b>E</b>                 | <b>D</b>                 | <b>C</b>                 | <b>B</b>                 | <b>A</b>                 | <b>A+</b>                | <b>A++</b>               | <b>A+++</b>              |
| < 30%                    | ≥ 30%                    | ≥ 34%                    | ≥ 36%                    | ≥ 75%                    | ≥ 82%                    | ≥ 90%                    | ≥ 98%                    | ≥ 125%                   | ≥ 150%                   |

The energy efficiency of the package of products provided for in this document may not correspond to its actual energy efficiency once installed in a building, as the efficiency is influenced by further factors such as heat loss in the products in relation to the building size and its characteristics

## NOTES FOR THE INSTALLER

For any technical queries please ring the Ideal installer helpline : 01482 498663

### **BOILER RESTART PROCEDURE -**

**Press the RESTART button. The boiler will repeat the ignition sequence if a heat demand is present.**

## DEFINITIONS



**WARNING:** Risk of injury or death



**CAUTION:** Risk of damage to objects



**IMPORTANT:** Important information

## Table of Acronyms

**CH** - Central Heating

**DHW** - Domestic Hot Water

**TRV** - Thermostatic Radiator Valve

**PRV** - Pressure Relief Valve

**IE** - Ireland

**ETCI** - Electro-Technical Council of Ireland

**BS** - British Standard

**WRAS** - Water Regulations Advisory Scheme

**SAP** - Standard Assessment Procedure

**IET** - Institution of Engineering and Technology

**UKCA** - UK Conformity Assessed

**RHS** - Right Hand Side

**LHS** - Left Hand Side

**PCB** - Printed Circuit Board

# CONTENTS

|   |    |   |                                   |    |
|---|----|---|-----------------------------------|----|
| Section 1 - General .....                           | 6  | 2.31  | Accessing the Installer Mode..... | 36 |
| 1.1 Introduction .....                              | 8  | 2.32  | Handing Over.....                 | 36 |
| 1.2 Operation .....                                 | 8  |   |                                   |    |
| 1.3 Safe Handling .....                             | 8  | Section 3 - Servicing.....  |                                   | 37 |
| 1.4 Optional Accessories .....                      | 8  | 3.1 Servicing Schedule .....                                      |                                   | 37 |
| 1.5 Safety.....                                     | 8  | 3.2 Removal / Replacement of Components.....                      |                                   | 38 |
| 1.6 Safe Handling of Substances .....               | 9  | 3.3 Draining the Boiler .....                                     |                                   | 38 |
| 1.7 Location of Boiler .....                        | 9  | 3.4 Boiler Front Panel Removal / Replacement.....                 |                                   | 38 |
| 1.8 Carbon Monoxide Alarms .....                    | 9  | 3.5 Flue Manifold Removal/Replacement.....                        |                                   | 39 |
| 1.9 Air Supply.....                                 | 9  | 3.6 Burner Removal and Cleaning.....                              |                                   | 39 |
| 1.10 Gas Supply .....                               | 10 | 3.7 Fan and Venturi Assembly Removal and Cleaning.....            |                                   | 40 |
| 1.11 Water Circulation System .....                 | 10 | 3.8 Cleaning the Heat Exchanger.....                              |                                   | 41 |
| 1.12 Boiler Controls .....                          | 10 | 3.9 Ignition / Detection Electrode Replacement / Inspection ..... |                                   | 41 |
| 1.13 Electrical Supply .....                        | 10 | 3.10 Cleaning / Replacing the Condensate Trap .....               |                                   | 42 |
| 1.14 Condensate Drain.....                          | 10 | 3.11 Return Thermistor Replacement.....                           |                                   | 42 |
| 1.15 Boiler Dimensions, Services & Clearances ..... | 11 | 3.12 Burner Injector Replacement.....                             |                                   | 42 |
| 1.16 System Requirements - Central Heating .....    | 12 | 3.13 Burner Replacement.....                                      |                                   | 43 |
| 1.17 System Balancing.....                          | 13 | 3.14 Spark Generator Replacement.....                             |                                   | 43 |
| 1.18 Water Treatment.....                           | 13 | 3.15 Gas Control Valve Replacement.....                           |                                   | 43 |
|   |    | 3.16 Condensate Trap Replacement / Cleaning.....                  |                                   | 44 |
| Section 2 - Installation .....                      | 14 | 3.17 Primary PCB Replacement.....                                 |                                   | 44 |
| 2.1 Boiler Assembly - Exploded View .....           | 14 | 3.18 Pressure Gauge Replacement .....                             |                                   | 45 |
| 2.2 Unpacking.....                                  | 15 | 3.19 PRV Replacement .....  |                                   | 45 |
| 2.3 Wall Mounting Template.....                     | 16 | 3.20 Pump Automatic Air Vent Replacement.....                     |                                   | 46 |
| 2.4 Preparing the Wall .....                        | 16 | 3.21 CH Water Pressure Switch Replacement.....                    |                                   | 46 |
| 2.5 Fitting the Wall Mounting Plate .....           | 16 | 3.22 Pump Head Replacement.....                                   |                                   | 47 |
| 2.6 Mounting the Boiler.....                        | 16 | 3.23 Flow Thermistor Replacement.....                             |                                   | 47 |
| 2.7 Flues and Locations.....                        | 17 | 3.24 Expansion Vessel Recharging & Replacement .....              |                                   | 48 |
| 2.8 Flues and Locations - Cont.....                 | 18 | 3.25 Heat Engine Replacement.....                                 |                                   | 49 |
| 2.9 Horizontal Flue Positions .....                 | 19 |   |                                   |    |
| 2.10 Vertical Flue Positions .....                  | 19 | Section 4 - Fault Finding.....                                    |                                   | 50 |
| 2.11 Flue System Dimensions .....                   | 20 | 4.1 Fault Finding Main Menu .....                                 |                                   | 50 |
| 2.12 Fitting the Turret.....                        | 20 | 4.2 'L 01' - Overheat Lockout.....                                |                                   | 51 |
| 2.13 Cutting the Flue .....                         | 21 | 4.3 'L 02' - Ignition Lockout.....                                |                                   | 51 |
| 2.14 Assembling the Vertical Flue .....             | 22 | 4.4 'L 06' - Flame On Before Gas Valve On.....                    |                                   | 52 |
| 2.15 Condensate Drain.....                          | 23 | 4.5 'F 01' - Low Water Pressure .....                             |                                   | 52 |
| 2.16 Condensate Drain - Continued .....             | 24 | 4.6 'F 02 or FN or LN' - Flame Loss.....                          |                                   | 52 |
| 2.17 Connections & Filling.....                     | 25 | 4.7 'F 03' - Fan Fault.....                                       |                                   | 53 |
| 2.18 Electrical connections.....                    | 26 | 4.8 F 04 or L 04' - Flow Thermistor Fault .....                   |                                   | 53 |
| 2.19 Installer Wiring.....                          | 26 | 4.9 'F 05 or L 05' - Return Thermistor Fault .....                |                                   | 54 |
| 2.20 Installer Wiring - Continued .....             | 27 | 4.10 'F 06' - Outside Sensor Fault .....                          |                                   | 54 |
| 2.21 Installer Wiring - Continued .....             | 28 | 4.11 No CH Operation .....  |                                   | 55 |
| 2.22 Replacing Pre-Fitted Mains Cable.....          | 29 | 4.12 No Display .....   |                                   | 56 |
| 2.23 External Electrical Controls.....              | 30 | 4.13 No DHW Operation.....  |                                   | 56 |
| 2.24 Wiring Diagram.....                            | 31 | 4.14 Flow/Return Differential Greater than 50°C.....              |                                   | 56 |
| 2.25 Commissioning and Testing.....                 | 32 |   |                                   |    |
| 2.26 Initial Lighting.....                          | 33 | Section 5 - Spare Parts .....                                     |                                   | 57 |
| 2.27 The Display.....                               | 34 |   |                                   |    |
| 2.28 General Checks.....                            | 34 | Section 6 - Benchmark to Commissioning.....                       |                                   | 58 |
| 2.29 General Checks - Water Circulation .....       | 35 |   |                                   |    |
| 2.30 Restart Procedure.....                         | 35 |   |                                   |    |

## Section 1 - General

**Table 1 General Data**

|   |                             | 15 kW                                   | 18 kW       | 24 kW        | 30 kW        |
|---|-----------------------------|---|-------------|--------------|--------------|
| Gas Supply                                |                             | 2H - G20 - 20 mbar                      |             |              |              |
| Gas Supply Connection                     |                             | 15 mm copper compression                |             |              |              |
| Injector Size                             | mm                          | 4.15                                    | 4.15        | 4.15         | 4.65         |
| Flow Connection                           | Central Heating             | 22 mm copper compression                |             |              |              |
| Return Connection                         | Central Heating             | 22 mm copper compression                |             |              |              |
| Flue Terminal Diameter                    | mm                          | 100                                     |             |              |              |
| Average Flue Temp-Mass Flow Rate          |                             | 56°C - 6g/s                             | 58°C - 8g/s | 63°C - 10g/s | 69°C - 13g/s |
| CO <sub>2</sub> Content (± 0.7)           | Max. CH                     | 9.5%                                    | 9.3%        | 9.2%         | 9.6%         |
|   | Min. CH                     | 8.9%                                    | 8.3%        | 8.5%         | 8.7%         |
| Maximum Working Pressure (Sealed Systems) | bar (psi)                   | 2.5(36.3)                               |             |              |              |
| Electrical Supply                         |                             | 230 V ~ 50Hz                            |             |              |              |
| Power Consumption                         | W                           | 72                                      | 75          | 96           | 100          |
| Fuse Rating                               |                             | External: 3A Internal : T4 A HRC L250 V |             |              |              |
| Water Content                             | Central Heating litre (gal) | 1.2(0.26)                               |             |              |              |
| Packaged Weight                           | kg                          | 31.3                                    |             |              |              |
| Lift Weight                               | kg                          | 27.3                                    |             |              |              |
| Boiler Casing Size                        | Height mm                   | 700                                     |             |              |              |
|   | Width mm                    | 395                                     |             |              |              |
|   | Depth mm                    | 278                                     |             |              |              |

**Table 2 Performance Data - Central Heating**

| Boiler Input:                           |                   | 15 kW   |       | 18 kW |       | 24 kW |       | 30 kW |       |
|---|-------------------|---------|-------|-------|-------|-------|-------|-------|-------|
|   |                   | Min     | Max   | Min   | Max   | Min   | Max   | Min   | Max   |
| Boiler 'Q' Net CV                       | kW                | 4.9     | 15.1  | 4.9   | 18.1  | 4.9   | 24.3  | 6.1   | 30.4  |
| Gross CV                                | kW                | 5.4     | 16.6  | 5.4   | 20.1  | 5.4   | 27.0  | 6.7   | 33.7  |
| Gas Consumption                         | m <sup>3</sup> /h | 0.500   | 1.537 | 0.500 | 1.872 | 0.500 | 2.512 | 0.623 | 3.136 |
| Boiler Output :                         |                   |         |       |       |       |       |       |       |       |
| Non Condensing<br>70°C Mean Water Temp. | kW                | 4.8     | 15.0  | 4.8   | 18.0  | 4.8   | 24.2  | 6.1   | 30.3  |
| Condensing<br>40°C Mean Water Temp.     | kW                | 5.1     | 15.9  | 5.1   | 19.1  | 5.1   | 25.6  | 6.4   | 31.0  |
| Seasonal Efficiency* SEDBUK 2005        |                   | 91.2%   |       | 91.1% |       | 91.2% |       | 91.1% |       |
| Seasonal Efficiency* SEDBUK 2009/2012   |                   | 89.4%   |       | 89.7% |       | 89.7% |       | 89.6% |       |
| NOx Classification                      |                   | Class 6 |       |       |       |       |       |       |       |

\* The value is used in the UK Government's Standard Assessment Procedure (SAP) for energy rating of dwellings. The test data from which it has been calculated have been certified by a notified body.

Gas consumption is calculated using a calorific value of 38.7 MJ/m<sup>3</sup> (1038 Btu/ft<sup>3</sup>) gross or 34.9 MJ/m<sup>3</sup> (935 Btu/ft<sup>3</sup>) nett

To obtain the gas consumption at a different calorific value:

- For l/s** - divide the gross heat input (kW) by the gross C.V. of the gas (MJ/m<sup>3</sup>)
- For Btu/h** - multiply the gross heat input (kW) by 26.8
- For ft<sup>3</sup>/h** - divide the gross heat input (Btu/h) by the gross C.V. of the gas (Btu/ft<sup>3</sup>)
- For m<sup>3</sup>/h** - multiply l/s by 3.6

**C<sub>13</sub> C<sub>33</sub> C<sub>53</sub>** = A room sealed appliance designed for connection via ducts to a horizontal or vertical terminal, which admits fresh air to the burner and discharges the products of combustion to the outside through orifices which, in this case, are concentric. The fan is up stream of the combustion chamber.

**I<sub>2H</sub>** = An appliance designed for use on 2nd family gas, Group H only.

**LOGIC SYSTEM<sup>2</sup> S**

Natural Gas Only

| BOILER SIZE kW | G.C. Appliance No (Benchmark No.) |
|----------------|-----------------------------------|
| 15             | 41-796-85                         |
| 18             | 41-796-86                         |
| 24             | 41-796-87                         |
| 30             | 41-796-88                         |

Destination Country: GB

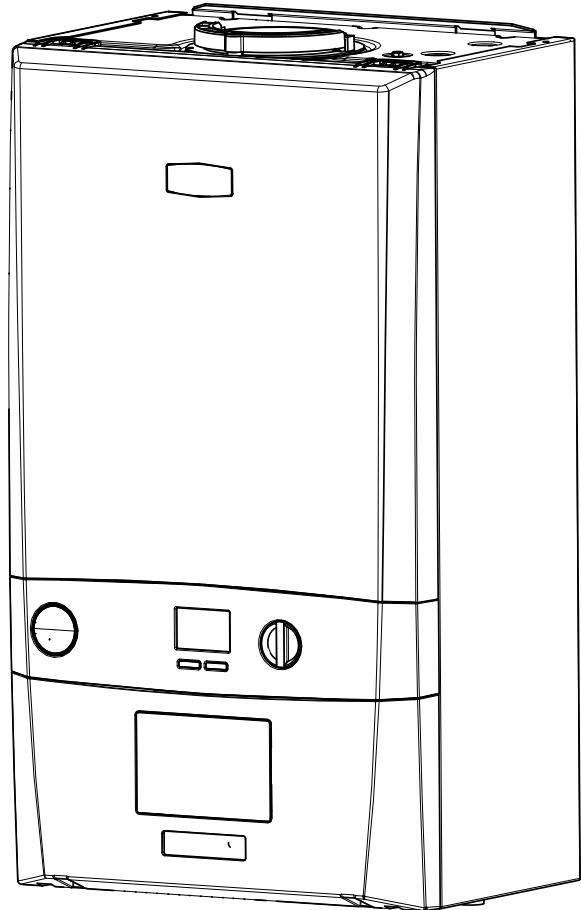

For UK, to comply with Building Regulations Part L1 (Part 6 in Scotland) the boiler should be fitted in accordance with the manufacturer's instructions. Self-certification that the boiler has been installed to comply with Building Regulations can be demonstrated by completing and signing the Benchmark Commissioning Checklist.

Before installing this boiler, read the Code of Practice sheet at the rear of this book.

**BENCHMARK COMMISSIONING CHECKLIST DETAILS**

| <b>Boiler</b>                                   | <b>Page</b>      | <b>Page</b>  |                    |
|---|------------------|--|--------------------|
| Make and model.....                             | 7                | Burner operating pressure .....                                    | n/a                |
| Appliance serial no. on data badge .....        | Front Cover      | Central heating flow temp. ....                                    | measure and record |
| SEDBUK No. %.....                               | 6                | Central heating return temp. ....                                  | measure and record |
| <b>Controls</b>                                 |                  | <b>For combination boilers only</b>                                |                    |
| Time and temperature control to heating .....   | 27               | Scale reducer .....  | 15                 |
| Time and temperature control to hot water ..... | 27               | <i>Hot water mode</i>  |                    |
| Heating zone valves.....                        | n/a              | Heat input.....  | to be calculated   |
| TRVs .....                                      | 10               | Max. operating burner pressure .....                               | n/a                |
| Auto bypass .....                               | 10               | Max. operating water pressure.....                                 | measure & record   |
| Boiler interlock.....                           | 10               | Cold water inlet temp .....  | measure & record   |
| <b>For all boilers</b>                          |                  | Hot water outlet temp. ....  | measure & record   |
| Flushing to BS.7593.....                        | 13               | Water flow rate at max. setting.....                               | measure & record   |
| Inhibitor .....                                 | 13               | <b>For condensing boilers only</b>                                 |                    |
| <i>Central heating mode</i>                     |                  | Condensate drain .....   | 23-24              |
| Heat input.....                                 | to be calculated | <b>For all boilers: Complete, sign &amp; hand over to customer</b> |                    |

**NOTE TO THE INSTALLER: COMPLETE THE BENCHMARK COMMISSIONING CHECKLIST AND LEAVE THESE INSTRUCTIONS WITH APPLIANCE**



For assistance call Technical Helpline  
01482 498663

# Section 1 - General

## 1.1 INTRODUCTION

The Logic System<sup>2</sup> range of boilers are wall mounted, condensing, system gas boilers.

Features:

- High efficiency
- Full sequence
- Automatic spark ignition
- Low water content
- Fanned flue

The boiler is supplied fully assembled with circulating pump, pressure gauge, PRV and CH expansion vessel.

A variable temperature control is fitted on the user control.

The boiler includes as standard:

- Boiler frost protection
- Daily pump exercise.

**Note.** The appliance must be wired with a permanent live supply, or the boiler frost protection will not operate. The boiler warranty will be invalid if this requirement is not complied with.

The boiler casing is of white painted mild steel with a white polymer front panel.

The boiler temperature control is visibly located in the control panel on the front of the boiler.

The heat exchanger is manufactured from cast aluminium.

The boiler is suitable for connection to fully pumped, sealed heating systems ONLY. Adequate arrangements for completely draining the system by provision of drain cocks MUST be provided in the installation pipework.

Pipework from the boiler is routed downwards.

### Data Plate

The boiler model and serial number can be located on the bottom of the boiler casing, shown in **1.15 Boiler Dimensions, Services & Clearances**

## 1.2 OPERATION

When there is a demand for CH, the heating system is supplied at the selected temperature of between 30°C and 80°C.

The boiler features a comprehensive diagnostic system which gives detailed information on the boiler status when operating, and performance of key components to aid commissioning and fault finding.

## 1.3 SAFE HANDLING

This boiler may require 2 or more operatives to move it to its installation site, remove it from its packaging base and during movement into its installation location. Manoeuvring the boiler may include the use of a sack truck and involve lifting, pushing and pulling.

Caution should be exercised during these operations.

Operatives should be knowledgeable in handling techniques when performing these tasks and the following precautions should be considered:

- Grip the boiler at the base.
- Be physically capable.
- Use personal protective equipment as appropriate, e.g. gloves, safety footwear.

During all manoeuvres and handling actions, every attempt should be made to ensure the following unless unavoidable and/or the weight is light.

- Keep back straight.
- Avoid twisting at the waist.
- Avoid upper body/top heavy bending.
- Always grip with the palm of the hand.
- Use designated hand holds.
- Keep load as close to the body as possible.
- Always use assistance if required.

## 1.4 OPTIONAL ACCESSORIES

Please visit [idealheating.com](http://idealheating.com) to access the optional accessories for this boiler.



## 1.5 SAFETY

### Current Gas Safety (installation and use) regulations or rules in force:

The appliance is suitable only for installation in GB and should be installed in accordance with the rules in force.

In GB, the installation must be carried out by a Gas Safe Registered Engineer. It must be carried out in accordance with the relevant requirements of the:

- Gas Safety (Installation and Use) Regulations
- Appropriate Building Regulations, either The Building Regulations, The Building Regulations (Scotland), Building Regulations (Northern Ireland).
- Water Fittings Regulations or Water byelaws in Scotland.
- Current IET Wiring Regulations.

Where no specific instructions are given, reference should be made to the relevant British Standard Code of Practice.

The Boiler has been tested and certified to;

BSEN 15502-1, BSEN 15502-2, BSEN 15502-2-1, BSEN 60335-1, BSEN 60335-2-102, BSEN 55014-1 and BSEN 55014-2 for use with Natural Gas & Propane.

Detailed recommendations are contained in the following British Standard Codes of Practice:

- BS5440:1** Flues (for gas appliances of rated input not exceeding 70 kW).
- BS5440:2** Ventilation (for gas appliances of rated input not exceeding 70 kW).
- BSEN. 12828** Heating Systems in buildings: Design for water based heating systems.
- BSEN 12831** Heating Systems in buildings: Method for calculation of the design heat load.
- BSEN 14336** Heating Systems in buildings: Installation and commissioning of water based heating systems.
- BS5546** Installation of gas hot water supplies for domestic purposes (2nd Family Gases)
- BS6798** Installation of gas fired hot water boilers of rated input not exceeding 70 kW.
- BS6891** Installation and maintenance of low pressure gas installation pipework.

# Section 1 - General

**BS 7593:2019** Code of practice for the preparation, commissioning and maintenance of domestic central heating and cooling water systems.

**Health & Safety Document No. 635.**

**The Electricity at Work Regulations, 1989.**

The manufacturer's notes must NOT be taken, in any way, as overriding statutory obligations.

**! IMPORTANT:** This appliance is UKCA/CE certificated for safety and performance. Do not connect external control devices directly to this appliance unless recommended in this manual or by **Ideal Heating** in writing. If in doubt, please enquire.

Unapproved control devices could invalidate the warranty of this appliance and infringe the Gas Safety Regulations.

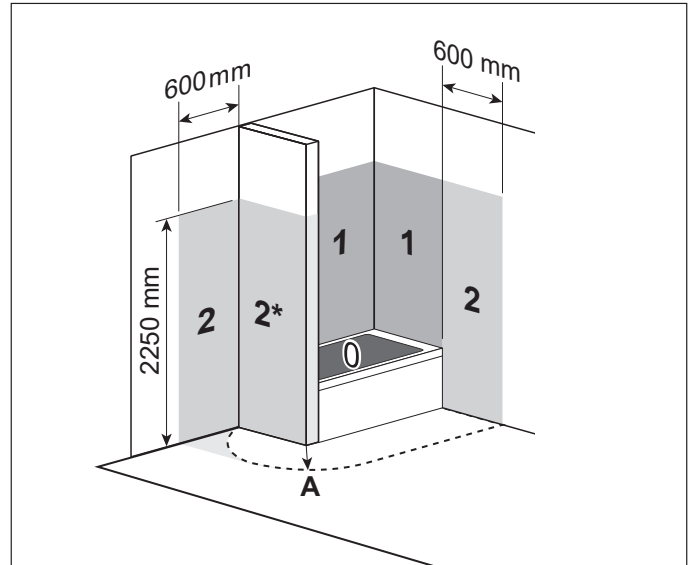

## 1.6 SAFE HANDLING OF SUBSTANCES

No asbestos, mercury or CFCs are included in any part of the boiler or its manufacture.

## 1.7 LOCATION OF BOILER

The boiler must be installed on a flat and vertical internal wall, capable of adequately supporting the weight of the boiler and any ancillary equipment.

The boiler may be fitted on a combustible wall and insulation between the wall and the boiler is not necessary, unless required by the local authority.

**! WARNING:** Rear access to the boiler is not permitted.

**! CAUTION:** Do not fit the boiler outside.

### Timber Framed Buildings

Boilers installed in a timber-framed building must comply with IGE/UP7 +A 2008.

### Bathroom Installations

**! CAUTION:** This appliance is IP20 rated, do not clean with jets of water.

You may install the boiler in any internal space. The installation must comply with the current IET (BS 7671) Wiring Regulations and the electrical regulations applicable in Scotland.

If the appliance is to be installed in a room containing a bath or shower then, the appliance must be installed beyond Zone 2, as detailed in BS7671.

### Bathroom Installations

[0] Zone 0

[1] Zone 1

[2] Zone 2

[2\*] Without the end wall, zone 2 must extend 600 mm from the bath

[A] 600 mm radius from the bath or shower

### Compartment Installations

A boiler installed in a compartment does not require ventilation. However, A boiler installed in a compartment must provide adequate clearances for servicing. The compartment should also be fitted with a suitable label in accordance with current standards.

Refer to Section 1.15

## 1.8 CARBON MONOXIDE ALARMS

When installing a new boiler, Installers should make sure that a suitable carbon monoxide alarm is installed near to the boiler.

**! IMPORTANT:** Carbon monoxide alarms must be installed in any room that has a fixed combustion appliance.

UK Building Regulations state that a carbon monoxide alarm should be installed in the room where:

- a new or replacement fixed combustion appliance (excluding an appliance used solely for cooking) is installed in the dwelling, or
- a new or replacement fixed combustion appliance is installed in a connected space such as an integral garage.

Users and Installers should comply with the Smoke and Carbon Monoxide Alarm (Amendment) Regulations 2022 and BS EN 50291-1:2010, and all applicable local building authority regulations.

Carbon monoxide detectors should use a battery designed to operate for the working life of the detector. Carbon monoxide detectors that are connected to the main electrical supply and comply with BS EN 50291-1:2010 (Type A) may be used, as long as a sensor failure warning device is installed. All detectors should include a warning device to alert the Users when the working life of the detector is scheduled to end.

## 1.9 AIR SUPPLY.

It is not necessary to have an air vent in the room or internal space where the boiler is installed.

## Section 1 - General

### 1.10 GAS SUPPLY

Consult the local gas supplier to establish an adequate supply of gas. Do not use existing service pipes without consulting the local gas supplier.

The gas supply must be governed with a meter.

A gas meter can only be connected by the local gas supplier or a Gas Safe Registered Engineer.

An existing meter should be checked, preferably by the gas supplier, to ensure that the meter is adequate to deal with the required gas supply rate.

It is the responsibility of the Gas Installer to size the gas installation pipework in accordance with BS6891.

Whilst the principle of the 1:1 gas valve ensures the Logic range is able to deliver it is full output at inlet pressures as low as 14 mb, other gas appliances in the property may not be as tolerant. When operating pressures are found to be below the minimum meter outlet of 19 mb these should be checked to ensure this is adequate for correct and safe operation.

Allowing for the acceptable pressure loss of 1mb across the installation pipework, it can be assumed that a minimum permitted operating pressure of 18mb will be delivered to the inlet of the appliance.

(Reference BS6400-1 Clause 6.2 Pressure Absorption).

The external gas cock could further reduce the operating pressure when measured at its test point. The pressure drop is relative to the heat input to the boiler (kW), refer to graph on P10.

**IMPORTANT:** Ensure all gas valve connections are gas tight with a gas soundness check up to the gas control valve.

Installation pipes must be fitted in accordance with BS6891.

The complete installation MUST be tested for gas tightness and purged as described, for the majority of installations the appropriate standard is IGEM/UP/1B [23], but alternatively IGEM/UP/1 [21] or IGEM/UP/1A [22], as appropriate, can be utilized.

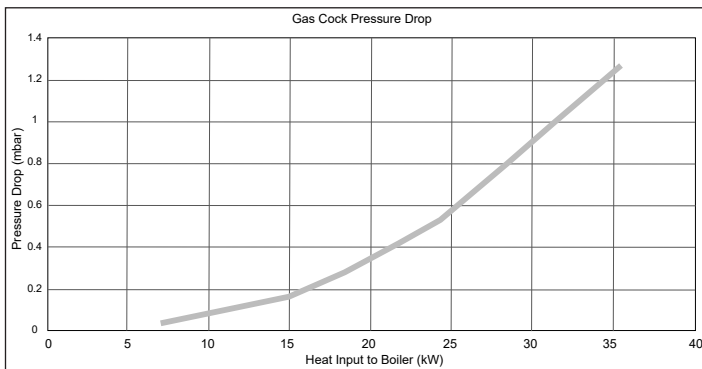

### 1.11 WATER CIRCULATION SYSTEM

**IMPORTANT:** A minimum length of 1 metre of copper pipe MUST be fitted to both flow and return connections from the boiler before connection to any plastic piping.

The central heating system should be in accordance with BS6798 and, in addition, for smallbore and microbore systems, BS EN 12828:2012+A1:2014..

Water treatment is covered later in these instructions.

Refer to Section  
1.18

### 1.12 BOILER CONTROLS

**WARNING:** This appliance must be earthed

Install CH controls to ensure that the boiler has no demand when there is no requirement from the system.

Heating systems with TRVs in individual rooms must include a thermostat to control the temperature in rooms without TRVs.

At least 10% of the minimum boiler heat output should be achieved using a room thermostat. A bypass circuit with an automatic bypass valve must be fitted to systems with TRVs or two-port valves on all the radiators to ensure water flow.

### 1.13 ELECTRICAL SUPPLY

Wiring external to the appliance MUST be in accordance with the current IET (BS7671) Wiring Regulations and any local regulations which apply.

The mains supply to the boiler and system wiring centre shall be through one common fused double pole isolator and for new heating systems, and where practical replacement installations, the isolator shall be situated adjacent to the appliance.

### 1.14 CONDENSATE DRAIN

The condensate drain provided must be connected to the drainage point on site. All condensate drainage pipework and fittings must be made of plastic.

**IMPORTANT:** The condensate drain pipework should be installed in accordance with BS6798.

The drain outlet on the boiler is sized for standard 21.5 mm overflow pipe. It is a universal fitting to allow use of different brands of pipework.

Refer to Section  
2.15

# 1.15 BOILER DIMENSIONS, SERVICES & CLEARANCES

Refer to Section 2.17

The boiler connections are made on the boiler connection tails.

**The following minimum clearances must be maintained for operation and servicing.**

Additional space will be required for installation, depending upon site conditions.

**Side and Rear Flue**

- a. Provided that the flue hole is cut accurately, e.g. with a core drill, the flue can be installed from inside the building where wall thicknesses do not exceed 600mm.

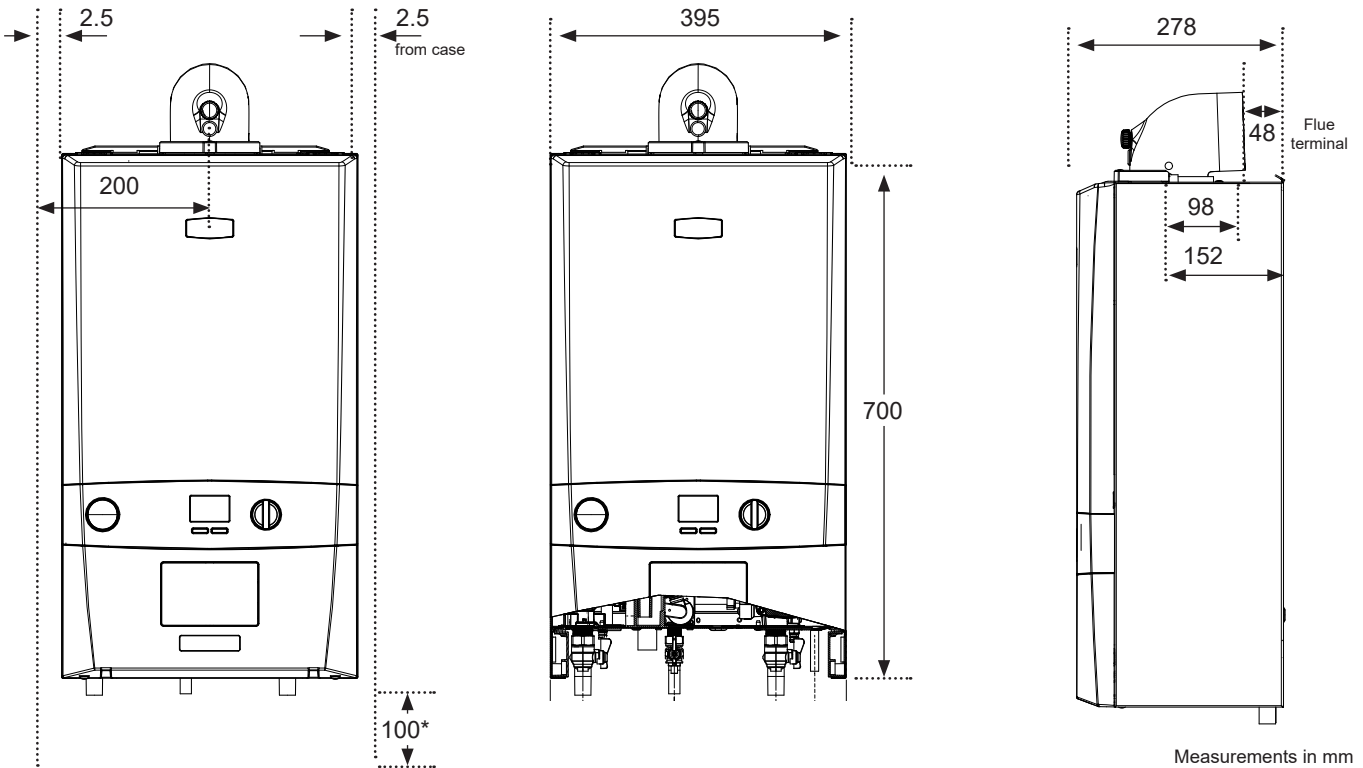

Measurements in mm

Water and Gas Connections

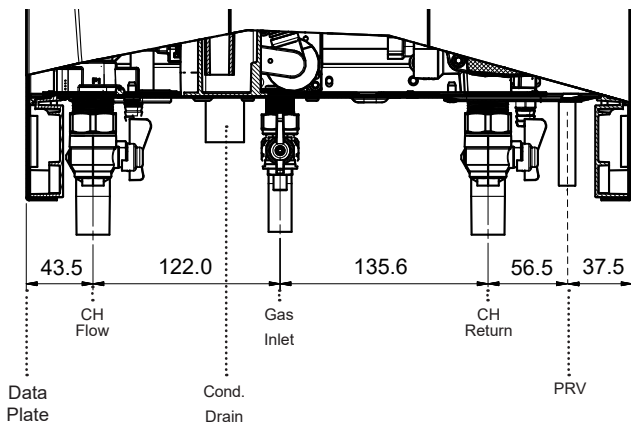

Underside View - Dimension to Wall

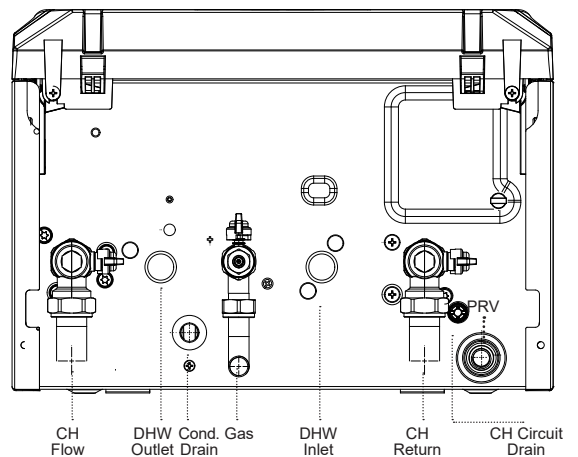

**Front Clearance**

The minimum front clearance when built in to a cupboard is 5mm from the cupboard door but 450mm overall clearance is still required, with the cupboard door open, to allow for servicing.

**\* Bottom Clearance**

Bottom clearance after installation can be reduced to 15mm.

This must be obtained with an easily removable panel to provide the 100mm clearance required for servicing.

**IMPORTANT:** Please ensure there is sufficient clearance either side and below the boiler, particularly from door hinges and the base of a cupboard.

## 1.16 SYSTEM REQUIREMENTS - CENTRAL HEATING

- a. The method of filling, refilling, topping up or flushing sealed primary hot water circuits from the mains via a temporary hose connection is only allowed if acceptable to the local water authority.
- b. Antifreeze fluid, corrosion and scale inhibitor fluids suitable for use with boilers having aluminium heat exchangers may be used in the central heating system.

### General

1. The installation must comply with all relevant national and local regulations.
2. Design the system for flow temperatures up to 80°C.
3. All components of the system must be suitable for a working pressure of 3 bar and a maximum design temperature of 110°C. Extra care should be taken in making all connections so that the risk of leakage is minimised.

The following components are incorporated within the appliance:

- a. Circulating pump.
  - b. PRV, with a non-adjustable preset lift pressure of 3 bar.
  - c. Pressure gauge, covering a range of 0 to 4bar.
  - d. An 8-litre expansion vessel, with an initial charge pressure of 0.75 bar.
4. **Makeup Water.** One of the following provisions must be made for replacing system water loss:
    - a. Manually filled vessel  
The vessel must:  
Have a visible water level  
Be mounted at least 150 mm above the system's highest point  
Connect through a non-return valve to the system  
Be at least 150 mm below the makeup vessel on the return side of the radiators
    - b. System prepressurisation.  
The efficiency of the expansion vessel will be reduced in a pressurised system; a larger vessel or smaller system volume may be necessary. If the vessel's capacity is not sufficient, an additional vessel must be installed on the return to the boiler.  
If the system is not pressurised, the cold water capacity must not exceed 143 litres.

Guidance on vessel sizing is given in table above.

### Water Flow Rate and Pressure Loss

| Model                     |           | 15     | 18     | 24     | 30    |
|---------------------------|-----------|--------|--------|--------|-------|
| Max CH output             | kW        | 15     | 18     | 24.2   | 30.3  |
| Water flow rate           | l/min     | 10.7   | 13     | 17.2   | 21.5  |
|                           | (gal/min) | (2.4)  | (2.8)  | (3.8)  | (4.7) |
| Temp differential         | °C        | 20     | 20     | 20     | 20    |
| Head available for system | m.w.g.    | 5      | 4.5    | 3.3    | 1.9   |
|                           | (ft.w.g.) | (16.2) | (14.7) | (10.8) | (6.2) |

**Table 3 Vessel Sizing**

|   |     |   |       |
|---|-----|---|-------|
| <b>PRV setting</b>  | bar | 3.0                                     |       |
| <b>Vessel charge pressure</b>                                 | bar | 0.5 to 0.75                             |       |
| <b>System pre-charge pressure</b>                             | bar | None                                    | 1.0   |
| <b>System volume (litres)</b>                                 |     | <b>Expansion vessel volume (litres)</b> |       |
| 25  |     | 1.6                                     | 1.8   |
| 50  |     | 3.1                                     | 3.7   |
| 75  |     | 4.7                                     | 5.5   |
| 100   |     | 6.3                                     | 7.4   |
| 125   |     | 7.8                                     | 9.2   |
| 150   |     | 9.4                                     | 11.0  |
| 175   |     | 10.9                                    | 12.9  |
| 190   |     | 11.9                                    | 14.0  |
| 200   |     | 12.5                                    | 14.7  |
| 250   |     | 15.6                                    | 18.4  |
| 300   |     | 18.8                                    | 22.1  |
| <b>For other system volumes multiply by the factor across</b> |     | 0.063                                   | 0.074 |

### 5. Filling

The system may be filled by the following method:

Where the mains pressure is excessive a pressure reducing valve must be used to facilitate filling.

- a. Thoroughly flush out the whole system with cold water.
- b. Fill and vent the system until the pressure gauge registers 1 bar and examine for leaks.

Refer to Section  
**2.17**

- c. Check the operation of the PRV by raising the water pressure until the valve lifts. This should occur within 0.3 bar of the preset lift pressure.
- d. Check no escape of water occurs except at the discharge point
- e. Release water from the system until the minimum system design pressure is reached; 1.0 bar if the system is to be pre-pressurised.

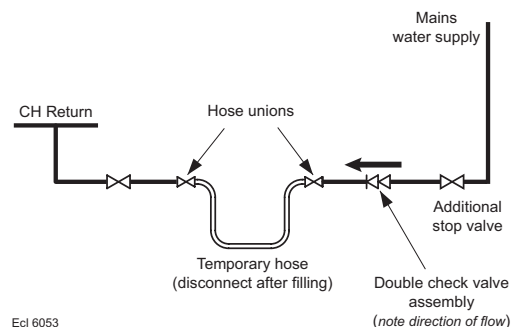

## 1.17 SYSTEM BALANCING

The boiler does not normally need a bypass but at least some radiators on the heating circuit, of load of at least 10% of the minimum boiler output, must be provided with twin lockshield valves so that this minimum heating load is always available. See note regarding thermostatic radiator valves on page 10.

**Note.** Systems incorporating zone valves which could completely cut off the flow through the system must also include a bypass.

### Balancing

1. Set the programmer to ON.  
Close the manual or thermostatic valves on all radiators, leaving the twin lockshield valves (on the radiators referred to above) in the OPEN position.  
Turn up the room thermostat and adjust the lockshield valve to give an uninterrupted flow through the radiator.  
These valves should now be left as set.
2. Open all manual or thermostatic radiator valves and adjust the lockshield valves on the remaining radiators, to give around 20°C temperature drop at each radiator.
3. Adjust the room thermostat and programmer to NORMAL settings.

## 1.18 WATER TREATMENT

### Central Heating

The Logic range of boilers have an ALUMINIUM alloy heat exchanger.

 **IMPORTANT** The application of any other treatment to this product may render the guarantee of Ideal Heating invalid.

**Ideal Heating** recommend Water Treatment in accordance with the Benchmark Guidance Notes on Water Treatment in Central Heating Systems.

If water treatment is used **Ideal Heating** recommend only the use of SCALEMASTER SM-1 PRO, FERNOX, MBI, ADEY MC1, SENTINEL X100 or CALMAG CM100 inhibitors and associated water treatment products, which must be used in accordance with the manufacturers' instructions.

This boiler can be used with a water softener. However, the heating system should not be filled with softened water as any softening chemicals could enhance corrosion of certain materials in the heating system, including aluminium and steel. The heating system should always be filled from the bypass on the water softener installation.

### Notes

1. It is most important that the correct concentration of the water treatment products is maintained in accordance with the manufacturers' instructions.
2. If the boiler is installed in an existing system any unsuitable additives **MUST** be removed by thorough cleansing. BS7593:2019 details the steps necessary to clean a domestic heating system.
3. In hard water areas, treatment to prevent lime scale may be necessary - however the use of artificially softened water is **NOT** permitted.
4. Under no circumstances should the boiler be fired before the system has been thoroughly flushed.

For further information contact:

Fernox  
www.fernox.com  
Tel: +44 (0) 3301 007750

Sentinel Performance Solutions  
www.sentinelprotects.com  
Tel: +44 (0) 1928 704330

Scalemaster Water Treatment Products  
www.scalemaster.co.uk  
Tel: +44 (0) 1785 811636

Calmag Ltd.  
www.calmag Ltd.com  
Tel: +44 (0) 1535 210320

Adey  
www.adey.com  
Tel: +44 (0) 1242 546700

## 2.1 BOILER ASSEMBLY - EXPLODED VIEW

|     |                         |     |                       |     |                               |     |                                       |
|-----|-------------------------|-----|-----------------------|-----|-------------------------------|-----|---------------------------------------|
| 104 | CH RETURN VALVE         | 131 | WATER PRESSURE SWITCH | 227 | CLAMP RETAINING FLUE TURRET   | 309 | HEAT EXCHANGER FLOW THERMISTOR & SEAL |
| 105 | CH FLOW VALVE           | 135 | PRESSURE GAUGE        | 228 | HOSE CONDENSATE INTERNAL      | 313 | IGNITION LEAD                         |
| 108 | PUMP HEAD               | 203 | GAS COCK              | 229 | SIPHON TRAP                   | 324 | CONTROLS BOX LID                      |
| 110 | PUMP AUTO AIR VENT      | 205 | GAS VALVE             | 231 | CONDENSATE OUTLET CONNECTION  | 325 | CONTROL BOX FRONT                     |
| 113 | PRESSURE RELIEF VALVE   | 206 | PIPE - GAS INJECTOR   | 239 | CONDENSATE DRAIN TUBE         | 401 | HEAT ENGINE                           |
| 114 | PIPE - PRV OUTLET       | 211 | INJECTOR ASSEMBLY     | 302 | PCB                           | 503 | WALL MOUNTING BRACKET                 |
| 115 | PIPE - FLOW             | 214 | VENTURI               | 304 | THERMISTOR RETURN             | 504 | FRONT PANEL                           |
| 116 | PIPE - RETURN           | 215 | FAN                   | 306 | ELECTRODE IGNITION/ DETECTION | 505 | FASCIA                                |
| 117 | PIPE - EXPANSION VESSEL | 217 | BURNER                | 308 | IGNITER UNIT                  | 506 | BRACKET - GAS VALVE                   |
| 118 | EXPANSION VESSEL        | 218 | GASKET - BURNER       |     |                               | 507 | BRACKET - EXPANSION VESSEL            |
| 120 | FLOW GROUP MANIFOLD     | 219 | SUMP CLEAN OUT COVER  |     |                               |     |                                       |
| 121 | BY-PASS KIT             | 223 | FLUE MANIFOLD         |     |                               |     |                                       |
|     |                         | 224 | FLUE MANIFOLD TOP     |     |                               |     |                                       |

Note that item numbers are linked to the spares list

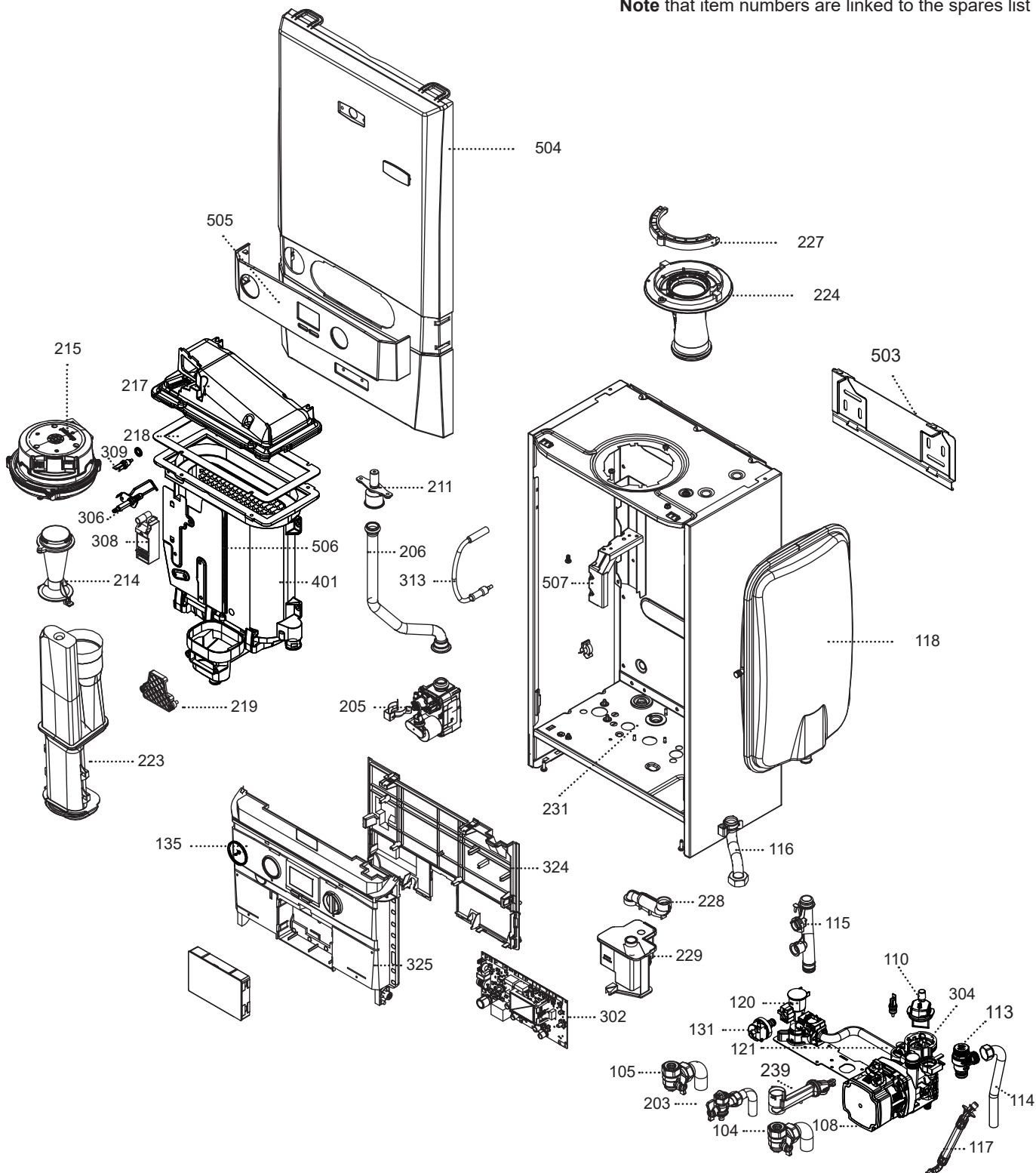

## 2.2 UNPACKING

The boiler is supplied fully assembled in Pack A.

### Pack A Contents

1. Boiler
2. Hardware Pack Box
3. Wall Mounting Plate
4. These Installation/Users Instructions
5. Wall Mounting Template
6. Boiler Warranty

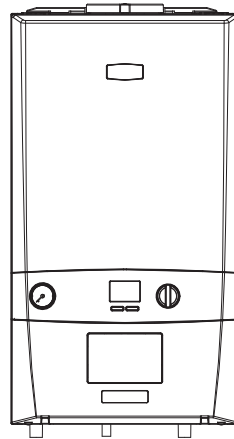

### Unpack and check the contents

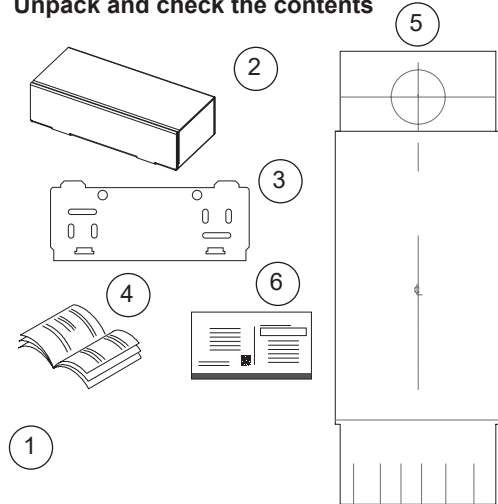

### Hardware Pack Box Contents

7. 2x Valve CH 3/4 x 22 mm\*
8. 1x Gas Cock

### Accessory Bag Contents

9. 2x Flow/Return Valve Washers\*
10. 1x Gas Cock Sealing Washer \*
11. 2x Wall Plugs
12. 2x Screws
13. 1x Flue Clamp Screw

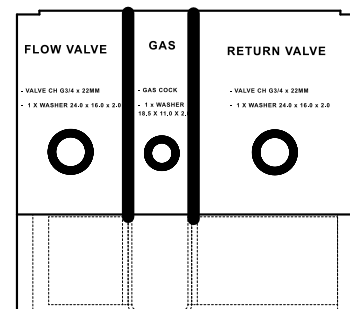
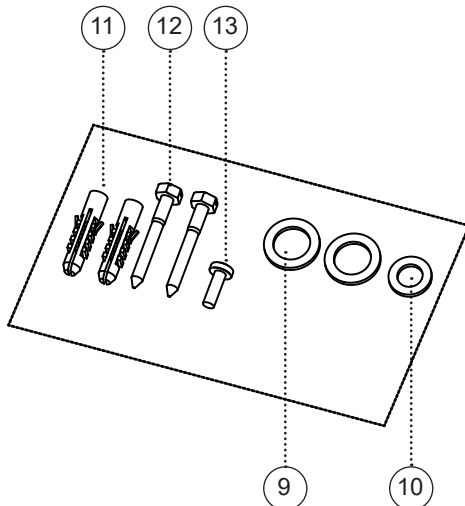
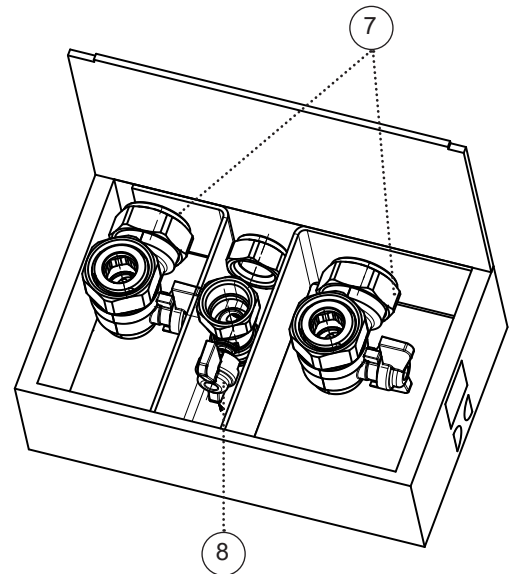

\*Refer to Valve Washer Template inside box lid.

## 2.3 WALL MOUNTING TEMPLATE

The wall mounting template is located on the internal protective packaging. The template shows the position of the fixing and rear flue centre holes for a standard installation

Care **MUST** be taken to ensure the correct holes are drilled.

1. Secure the template into the required position. Ensure it is square by hanging a plumbline.
2. If fitting a side flue, extend the flue centreline onto the side by 155 mm on a standard wall fix or 200 mm if using a stand-off bracket.
3. Mark the following on to the wall:
  - a The selected group of wall mounting screw holes.
  - b. The centre position of the flue duct. Marking both the centre and the circumference of the flue duct.
4. Remove the template plate from the wall.

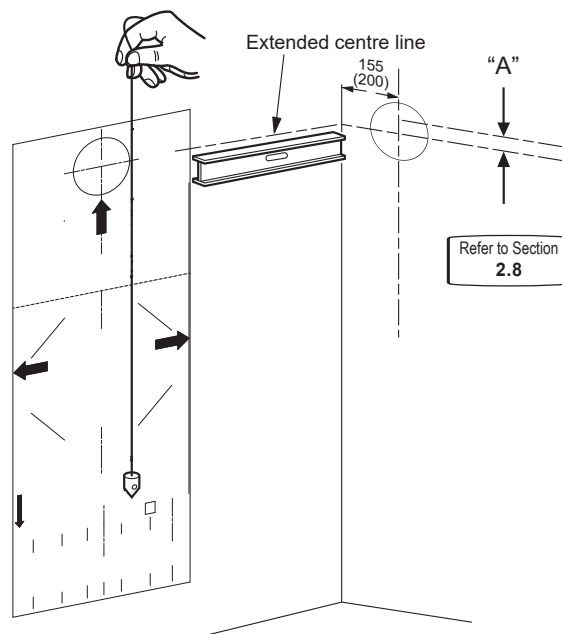

## 2.4 PREPARING THE WALL



**WARNING:** Ensure that, during the cutting operation, masonry falling outside of the building does not cause damage or personal injury.

1. Check all of the hole positions before drilling.
2. Cut the flue hole with a 127 mm core boring tool, ensure the hole is square to the wall.
3. Drill the 2 mounting holes with a 7.5 mm / 8 mm masonry drill and insert the plastic plugs provided.
4. Locate 2 No.14 x 50 mm screws in the wall mounting plate (one at each side, in any of the 3 holes provided at each side) and screw home. Ensure mounting bracket is level.

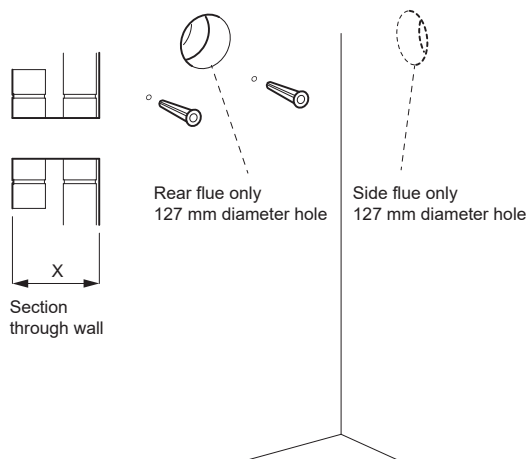

## 2.5 FITTING THE WALL MOUNTING PLATE

Screw the wall mounting plate to the wall using 2 wall plugs fitted previously with the 2 screws provided.

Choose one of the 2 sets of slots in left and right bank. Ensure that at least one of the screws is fitted into a top slot and the mounting bracket is level.

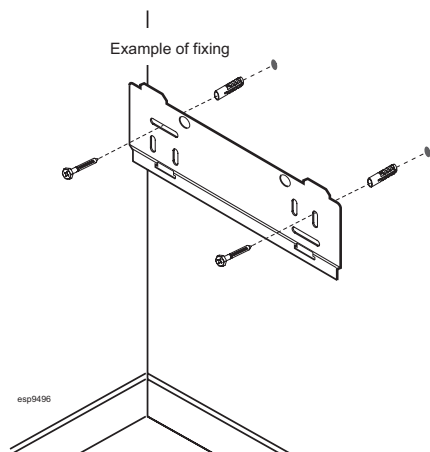



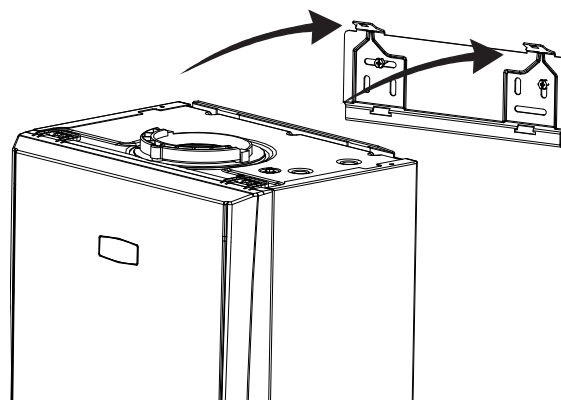

## 2.6 MOUNTING THE BOILER

1. Lift the boiler onto the wall mounting plate and locate it over the 2 tabs.

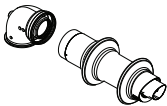
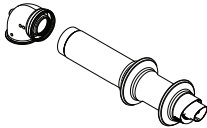

## 2.7 FLUES AND LOCATIONS

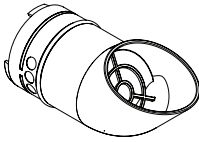
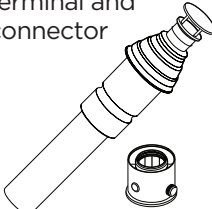
These Installation & Servicing Instructions must be read with all other instructions that may be supplied with the flue components. The Flue Guide can be downloaded from: <https://idealheating.com/logic-V4-literature-11>. Also available is an online video that shows you how to install the flue pipework.

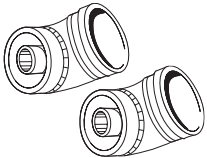
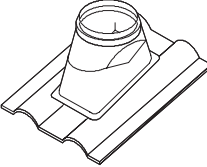
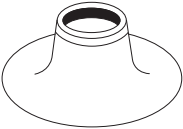
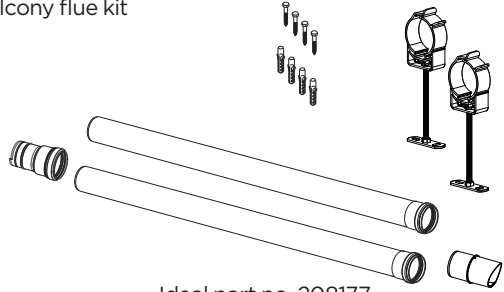
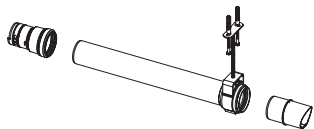
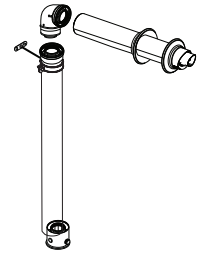
|  |   |  |   |  |
|--|---|--|---|--|
| <p>Telescopic horizontal flue<br/>0.5 or 0.7 m</p>  <p>Ideal part no.<br/>0.5 m 208169<br/>0.7 m 208174</p> | <p>Horizontal flue<br/>0.6 or 0.8 m</p>  <p>Ideal part no.<br/>0.6 m 208171<br/>0.8 m 217442</p> | <p>Flue extension<br/>0.5 m, 1 m or 2 m</p>  <p>Ideal part no.<br/>0.5 m 211037<br/>1 m 203129<br/>2 m 211038</p> | <p>Flue deflector</p>  <p>Ideal part no.<br/>208176</p>           | <p>Vertical flue terminal and connector</p>  <p>Ideal part no.<br/>211039</p> |
| <p>Flue elbow 90°</p>  <p>Ideal part no.<br/>203130</p>   | <p>Flue elbow 45°</p>  <p>Ideal part no.<br/>203131</p>  | <p>Weather collar pitched roof</p>  <p>Ideal part no.<br/>152258</p>  | <p>Weather collar flat roof</p>  <p>Ideal part no.<br/>152259</p> |  |
| <p>Balcony flue kit</p>  <p>Ideal part no. 208177</p>   | <p>Soffit kit</p>  <p>Ideal part no. 211302</p>   | <p>Raised horizontal flue kit</p>  <p>Ideal part no. 208290</p>   |   |  |

**WARNING:**

- It is critical that products of combustion cannot re-enter the building.
- The flue terminal must always have a free passage of air.

**CAUTION:**

- White sections of the flue must not be visible outside.
- Install a flue terminal guard where the flue terminal is less than 2 metres above a platform where persons can walk or come into contact with the terminal.
- Water is the only permitted lubricant for flue assembly.

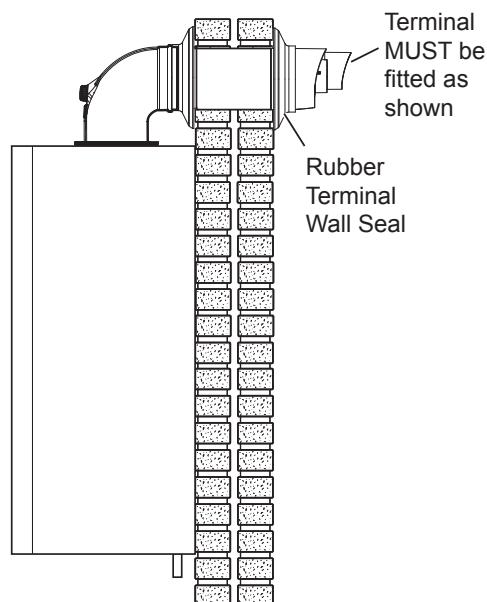

FLUE OUTLET

2.8 FLUES AND LOCATIONS - CONT

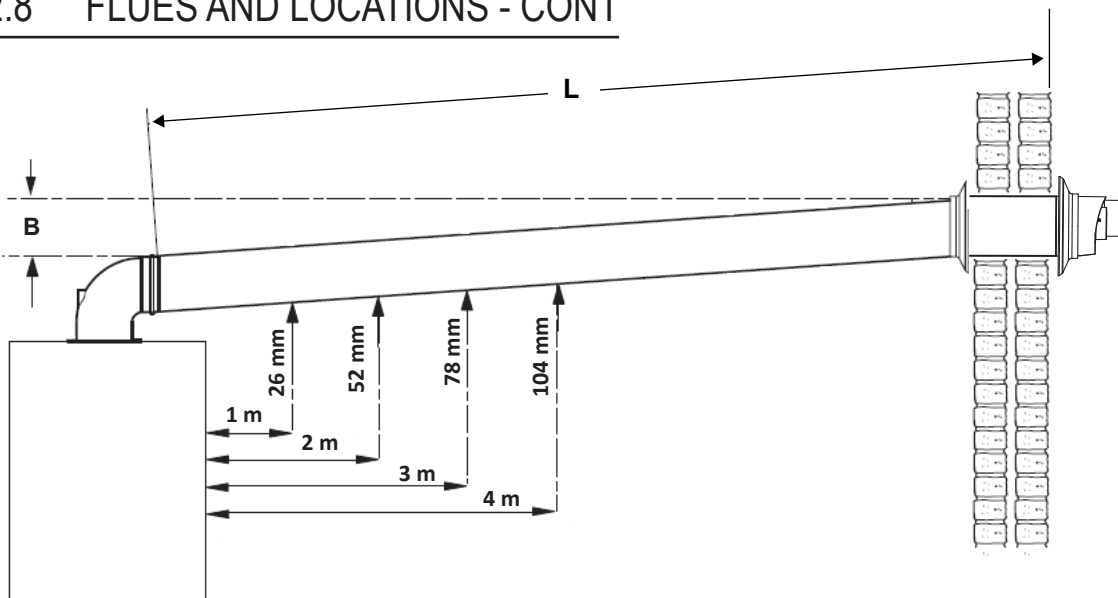

\* Ensure the flue terminal is horizontal when passing through the wall. Any flue extensions should be fitted with a 1.5° decline.

**B = Top Clearance**

Top Clearance is measure from the top of the turret to the top of the hole where the flue terminates.

**L = Effective flue length.**

The effective length of the flue is measured from the edge of the turret to the flue terminal lip.

Flue systems that require extension kits must be installed with a 1.5° decline from the flue terminal back to the boiler. A 1.5° decline can be achieved by designing the flue with a 26 mm rise per meter length of flue.

**! IMPORTANT INFORMATION**

Install the flue in accordance to BS 5440:1 2008  
Position the terminal, so the products of combustion do not cause a nuisance.

The terminal outlet duct must not be closer than 25 mm to combustible material.

The flue is secured in the wall using either sand and cement or heatproof silicone.

The flue must be supported by a bracket every metre of flue length and at every change of direction. Concealed flues must have inspection hatches no more than 1.5 metres from joints.

Where possible inspection hatches should be located at change of directions. Where this is not possible then bends must be viewable from both sides.

Inspection hatches must be at least 300 mm<sup>2</sup>.

Table 4 - Flue Terminal Position

| Flue Terminal Positions  | Min. Spacing*            |
|--|--------------------------|
| 1. Directly below, above or alongside an opening.                            | 300 mm                   |
| 2. Below guttering, drain pipes or soil pipes.                               | 75 mm<br>25 mm*          |
| 3. Below eaves.  | 200 mm<br>25 mm*         |
| 4. Below balconies or a car port roof.                                       | 200 mm<br>25 mm*         |
| 5. From vertical drain pipes or soil pipes.                                  | 150 mm<br>25 mm*         |
| 6. From an internal or external corner or a boundary alongside the terminal. | 300 mm<br>25 mm*         |
| 7. Above adjacent ground, roof or balcony level.                             | 300 mm                   |
| 8. From a surface or a boundary facing the terminal.                         | 600 mm                   |
| 9. From a terminal facing a terminal.  | 1200 mm                  |
| 10. From an opening in a car port into dwelling.                             | 1200 mm                  |
| 11. Vertically from a terminal on the same wall.                             | 1500 mm                  |
| 12. Horizontally from a terminal wall.                                       | 300 mm                   |
| 13. Horizontally from an adjacent window                                     | 600 mm                   |
| 14. Facing an opening into an adjacent building                              | 2000 mm                  |
| 15. At an angle to the boundary  | 90° 300 mm<br>45° 600 mm |
| 16. Parallel to a boundary   | 300 mm                   |
| 17. Below ground level – open light well                                     |                          |
| a) Below ground  | <1,000 mm                |
| b) Above floor level   | 300 mm                   |
| c) From side   | 300 mm                   |
| d) From facing surface   | 600 mm                   |

\*Only one reduction down to 25mm is allowed per installation.

| Horizontal | Maximum Effective Flue Length |
|------------|-------------------------------|
| 15-24 kW   | 9.0 metres                    |
| 30 kW      | 8.0 metres                    |
| Vertical   |                               |
| 15-30 kW   | 7.5 metres                    |

Elbows increase resistance and have an effective flue length equivalence. The following table is an example.

| Part      | Resistance |
|-----------|------------|
| 45° elbow | 0.6 metres |
| 90° elbow | 1.0 metres |

FLUE OUTLET

## 2.9 HORIZONTAL FLUE POSITIONS

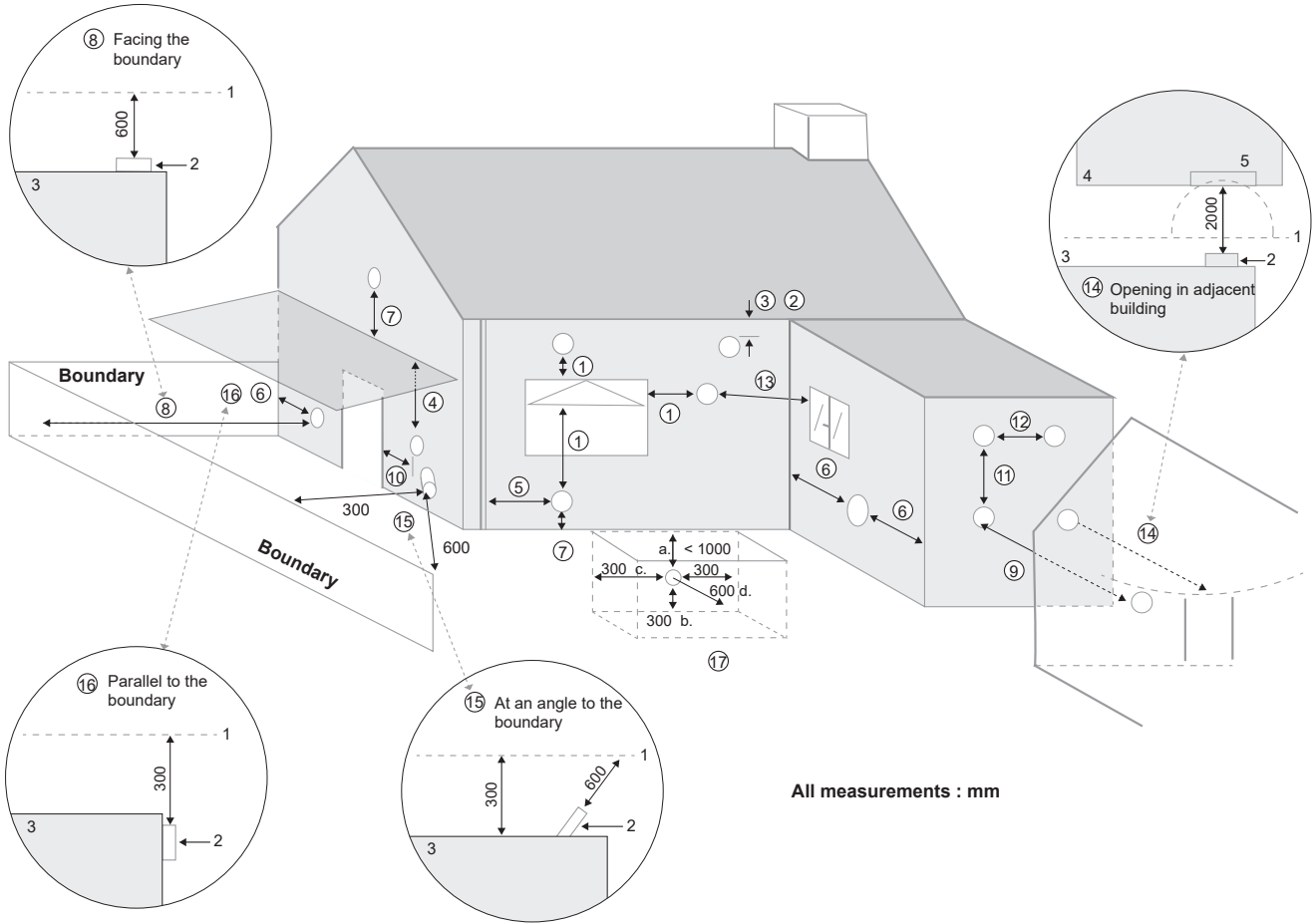

Refer to Table 4

## 2.10 VERTICAL FLUE POSITIONS

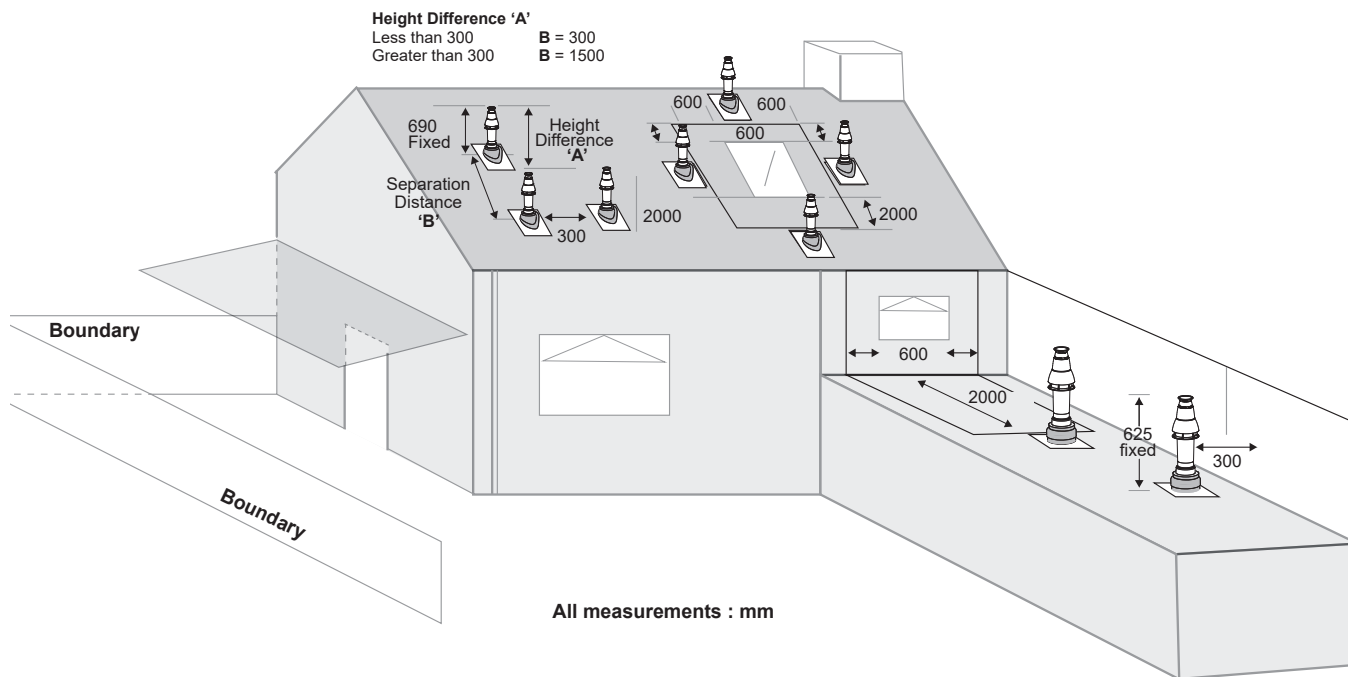

Refer to Table 4

FLUE OUTLET

## 2.11 FLUE SYSTEM DIMENSIONS

### Flue Design

#### ⚠ IMPORTANT:

1. Flue lengths may vary, always measure flue lengths before cutting.
2. Effective flue length and actual flue length are different measurements.
3. Effective flue length is made up of the flue length equivalence and the flue sections between the turret, elbows and terminal.
4. Actual flue length is the amount of flue needed to achieve the effective flue length, this includes insertions.
5. It is recommended that a support bracket is fitted on every 1 metre of pipe work used and the bracket is located as close to the collar as possible. The bracketing must ensure a 1.5 degree fall back to the appliance.

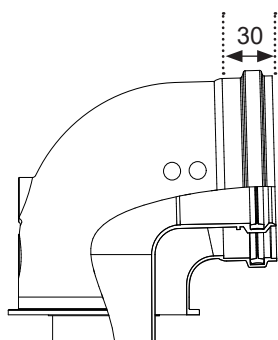

Turret insertion (mm)

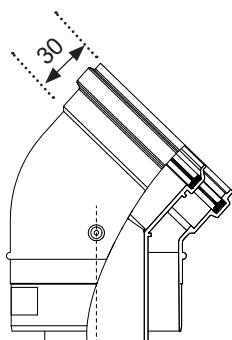

Elbow insertion (mm)

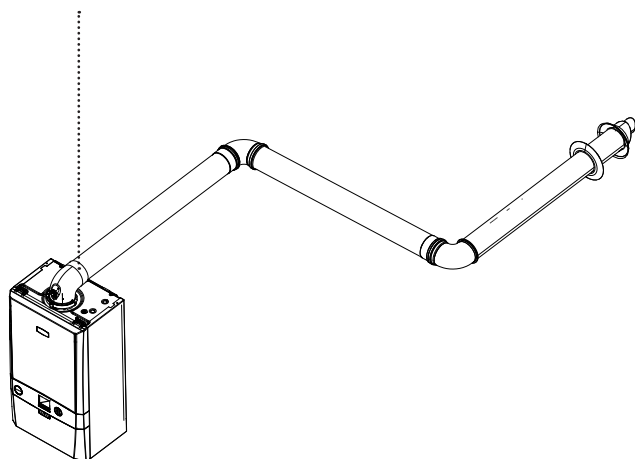

## 2.12 FITTING THE TURRET

1. Ensure the condensate trap is filled with water
2. Ensure the rubber seal is not damaged and fitted correctly on the appliance manifold.
3. Firmly hold the flue and push the turret on until it has travelled 30 mm ensuring the flue has not rotated or moved forward.
4. Push the turret into the manifold ensuring the upper plastic lip is flush with the top of the manifold.
5. Fully engage the clamp location section into the manifold location hole and rotate down onto the flange.
6. Use the securing screws to secure the clamp to the appliance.
7. Ensure all sample points are accessible and all sample plugs and caps are fitted.

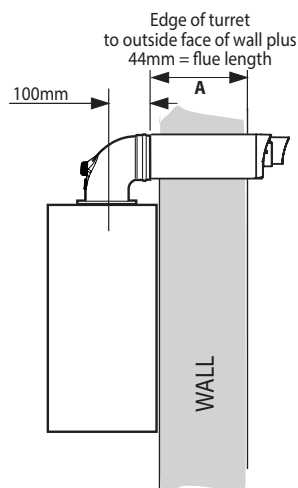
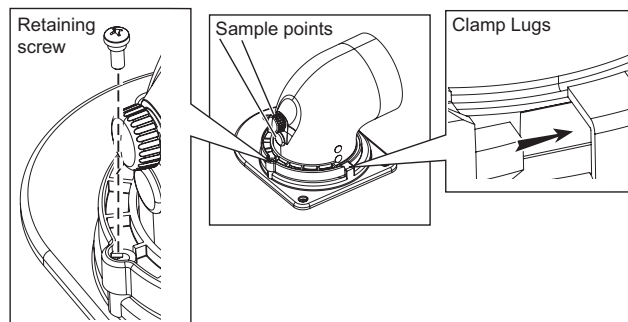
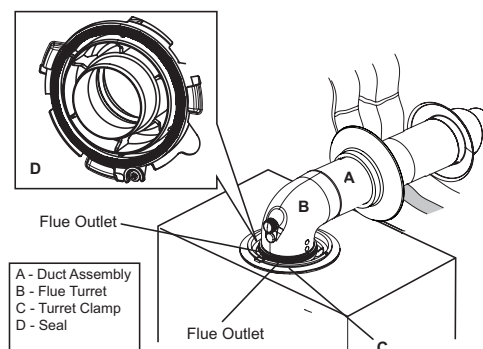

| Part                | Actual Length | Insertion | Effective Length |
|---------------------|---------------|-----------|------------------|
| 1 m flue length     | 1000 mm       | 30 mm     | 970 mm           |
| 90° elbow           |               | n/a       | 1000 mm          |
| 1 m flue length     | 1000 mm       | 30 mm     | 970 mm           |
| 90° elbow           |               | n/a       | 1000 mm          |
| 0.6 m flue terminal | 600 mm        | 30 mm     | 570 mm           |
| Total               |               |           | 4.510 mm         |

## 2.13 CUTTING THE FLUE

### CUTTING HORIZONTAL FLUE TERMINAL (non-telescopic)

1. Measure the required cut flue length ( $A + 44$  mm)
2. Measure from the outer terminal lip to the end of outer tube. Mark the required cut length ( $A + 44$  mm) around the circumference of the outer tube and cut following the mark to ensure it is cut square.
3. Mark and cut the inner tube 10 mm longer than the outer tube ensure the cut is square.
4. Remove all burrs on the inner and outer tube and place a light chamfer on the inner tube to aid with assembly.

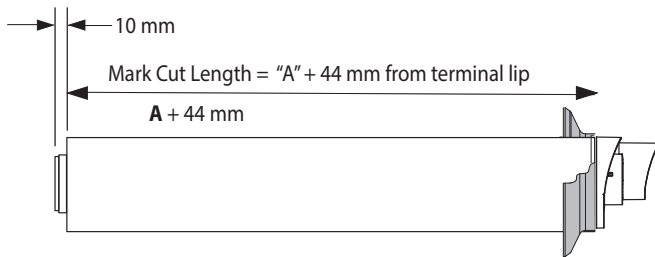

### SETTING TELESCOPIC FLUE

1. Measure the required length ( $A + 44$  mm)
2. Pull flue apart until the desired length is achieved ensuring the stop mark is not visible.
3. Ensure both flue seams are at the top and the flue outlet terminal is uppermost.
4. Drill a 3.5 mm hole through the small and large outer tube using the pilot hole on the large outer tube.
5. Secure large and small outer tube using the screws provided.
6. Seal the joint on the out tube with the tape provided.
7. Fit the internal and external wall seals.

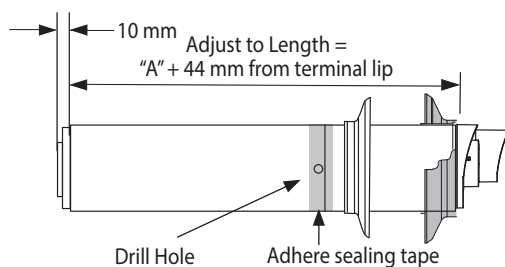

### FITTING THE FLUE THROUGH THE WALL (Internal Installation)

1. Measure the thickness of the wall.
2. To this measurement add 14 mm.
3. Make a mark on the flue shown as mark 1 (top right).
4. Make another mark on the flue a further 14 mm in shown as Mark 2 above right.
5. Fit the external wall seal (black) to the flue terminal ensuring it is fitted on the terminal outer lip seal.
6. Fit the inner wall seal approximately 65 mm prior to Mark 2.

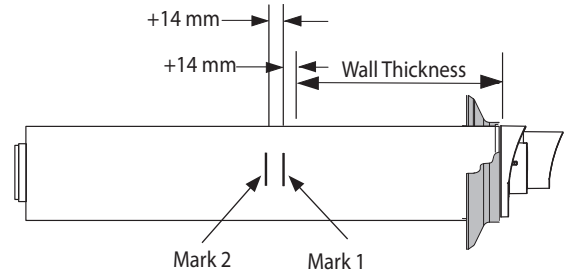

7. Place the terminal end of the flue into the 127 mm core drilled centrally and slowly apply slight pressure and move the flue up or down or side to side. This will cause the external wall seal to fold in and allow the flue to pass through the wall.
8. When the inner wall seal is flush against the wall pull back the flue until Mark 1 is flush with the inner wall surface.
9. Hold the flue steady and push the inner wall seal towards the wall until Mark 2 is just visible.

### FITTING THE FLUE THROUGH THE WALL (External Installation)

1. Follow steps 1 - 5 from above.
2. Push the flue through the 127 mm core drilled hole from the outside
3. Return inside the property and fit the inner wall seal to the flue.
4. Pull the flue internally until Mark 1 is flush with the inner wall surface.
5. Holding the flue in this position push the inner wall seal towards the wall until Mark 2 is just visible.

If Mark 1 is not flush with the inner wall surface and can be seen prior to the wall surface, then the external wall seal will have been dislodged and will require to be re-fitted. If this situation occurs, then please start the process from the beginning.

On completion the flue will be correctly installed as below.

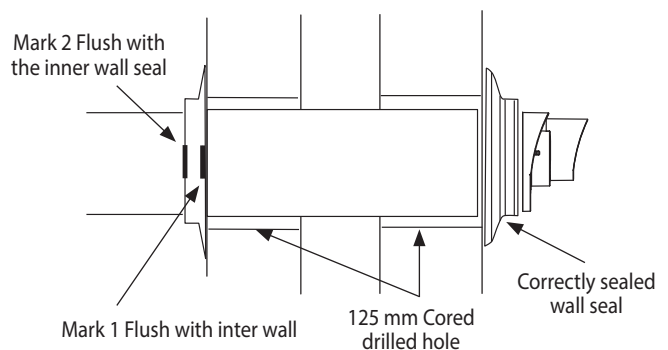

**IMPORTANT:** Ensure no White flue is visible between the flue terminal and the wall.

## Section 2 - Installation

A video showing how to correctly measure and fit a flue can be found by viewing the QR Code.

**SCAN**  
for Flue Fitting  
Video's



For the full range of FLUE ACCESSORIES please visit:  
<https://idealheating.com/logic-V4-literature-11>.

**SCAN**  
for Flues and  
Accessories Guide



### 2.14 ASSEMBLING THE VERTICAL FLUE

Determine the correct height that the flue should terminate above the roof. If after calculating or measuring the overall flue height from the top of the boiler, it is necessary to cut both pipes of assembly A, then ensure they are cut equally leaving the inner flue tube longer than the outer air tube as supplied.

Ensure the cut pipe ends are free from any burrs.

1. Position the roof flashing plate (supplied separately) over the hole cut in the roof and insert flue terminal from the roof end.
2. Fit the vertical connector (supplied in kit) in accordance with the instructions provided.
3. Secure the vertical connector by applying downward pressure on the connector.
4. Position the clamp on the top face of the flue manifold and push it horizontally backwards. Locate both clamp lugs into the flue manifold and secure to the flue manifold with the M5 retaining screw.

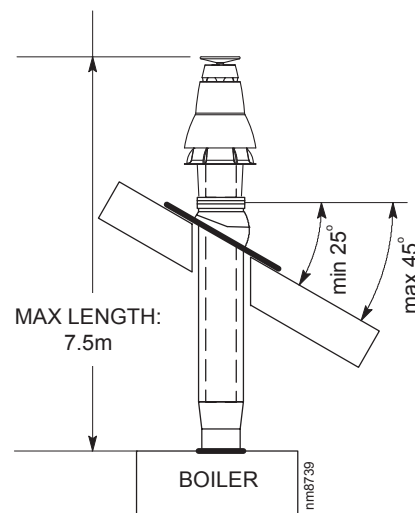

**Note.** Check the position of the inner flue duct relative to the outer duct on the assembled extension duct(s) and ensure the terminal flue duct is cut longer than the air duct to ensure engagement in the final flue duct seal.

7. Finally ensure the roof flashing plate is correctly sealed to the roof.

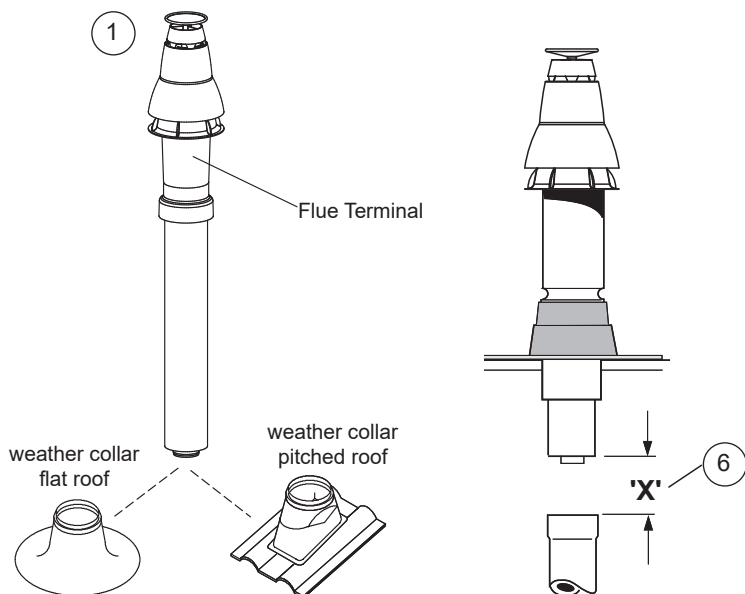

5. Push extension duct (if required (supplied separately)) into vertical connector.

**Note.** Ensure turret sample points are servicable and all caps and plugs are fitted. Fill the condense trap/siphon with water.

6. If the last extension duct requires cutting, measure 'X', the distance (outer ducts), between the duct and the terminal and add 100 mm to this dimension. This gives the length of the last extension duct.

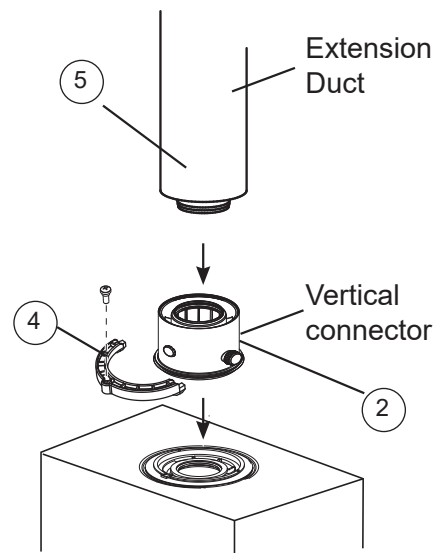

## 2.15 CONDENSATE DRAIN

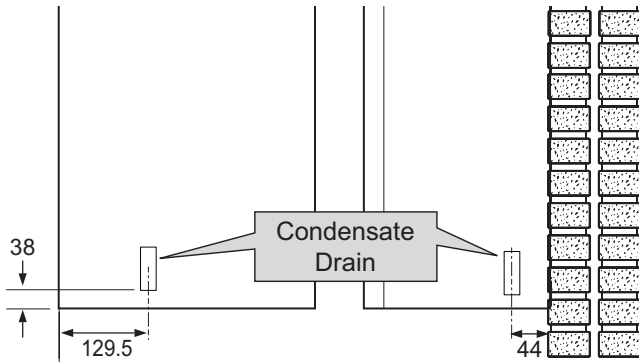

This appliance is fitted with a siphonic 75mm condensate trap system that requires filling before operating the appliance for the 1st time or after maintenance.

All condensate pipework should conform to the following:

- a. Where a new or replacement boiler is being installed, access to an internal 'gravity discharge' termination should be one of the main factors considered in determining boiler location.
- b. Plastic with push fit or solvent connections.
- c. Internal plastic pipe work a minimum of 19mm ID (typically 22mm OD).
- d. External plastic pipe must be a minimum of 30mm ID (typically 32 OD) before it passes through the sleeved wall.
- e. All horizontal pipe runs must fall a minimum of 52mm per metre away from the Boiler.
- f. External & unheated pipework should be kept to a minimum and insulated with Class "O" waterproof pipe insulation (UV Resistant).
- g. All installations must be carried out in accordance to the relevant connection methods as shown in the "Condensate installation diagrams" & BS6798.
- h. Pipework must be installed so that it does not allow spillage into the dwelling in the event of a blockage (through freezing)
- i. All internal burrs should be removed from the pipe work and any fittings.

In order to minimise the risk of freezing during prolonged very cold spells, one of the following methods of terminating condensate drainage pipe should be adopted.

### Internal Drain Connections

Wherever possible, the condensate drainage pipe should be routed to drain by gravity to a suitable internal foul water discharge point such as an internal soil and vent stack or kitchen or bathroom waste pipe etc.

Refer to Fig.  
1 & 2

### Condensate Pump

Where gravity discharge to an internal termination is not physically possible or where very long internal pipe runs would be required to reach a suitable discharge point, a condensate pump of a specification recommended by the boiler or pump manufacturer should be used terminating into a suitable internal foul water discharge point such as an internal soil and vent stack or internal kitchen or bathroom waste pipe etc.

Refer to Fig.  
3

### External Drain Connections

The use of an externally run condensate drainage pipe should only be considered after exhausting all internal termination options as described previously. An external system must terminate at a suitable foul water discharge point or purpose designed soakaway. If an external system is chosen then the following measures must be adopted:

The external pipe run should be kept to a minimum using the most direct and "most vertical" route possible to the discharge point, with no horizontal sections in which condensate might collect.

- For connections to an external soil/vent stack. Insulation measures as described should be used.

Refer to Fig.  
4

- When a rainwater downpipe is used, an air break must be installed between the condensate drainage pipe and the downpipe to avoid reverse flow of rainwater into the boiler should the downpipe become flooded or frozen.

Refer to Fig.  
5

- Where the condensate drain pipe terminates in a purpose designed soakaway (see BS 6798) any above ground condensate drain pipe sections should be run and insulated as described above.

Refer to Fig.  
6

- Where the condensate drain pipe terminates over an open foul drain or gully, the pipe should terminate below the grating level, but above water level, to minimise "wind chill" at the open end. The use of a drain cover (as used to prevent blockage by leaves) may offer further prevention from wind chill.

### Unheated Internal Areas

Internal condensate drain pipes run in unheated areas, e.g. lofts basements and garages, should be treated as external pipe.

Ensure the customer is aware of the effects created by a frozen condensate and is shown where this information can be found in the user manual.

**Note.** Please check current HHIC condensate discharge guidance available via the Gas Safe Registered Technical Bulletins List.

continued . . . . .

2.16 CONDENSATE DRAIN - CONTINUED

**Figure 1 - Connection of Condensate Drainage Pipe to Internal Soil & Vent Stack**

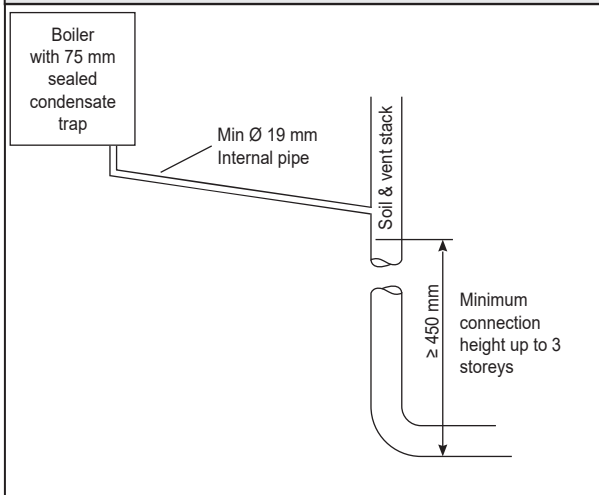

**Figure 2 - Connection of a Condensate Drainage Pipe Downstream of a Sink, Basin, Bath or Shower Water Trap to Internal Soil Vent Stack**

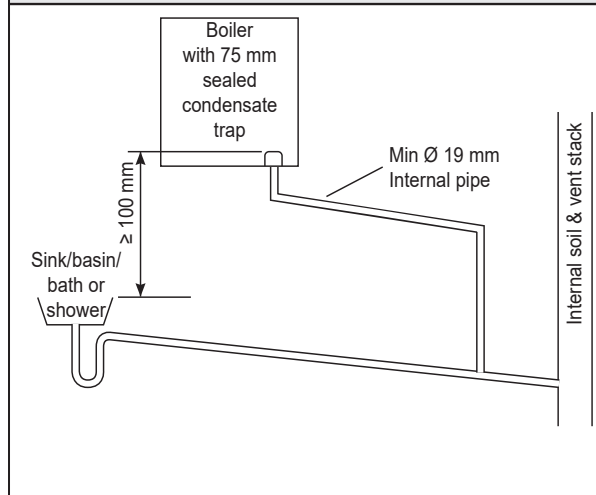

**Figure 3 - Connection of a Condensate Pump Typical Method (see manufacturer's detailed instructions)**

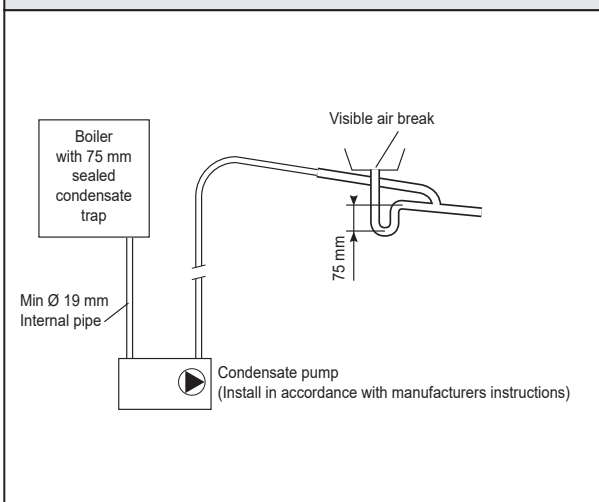

**Figure 4 - Connection of Condensate Drainage Pipe to External Soil & Vent Stack**

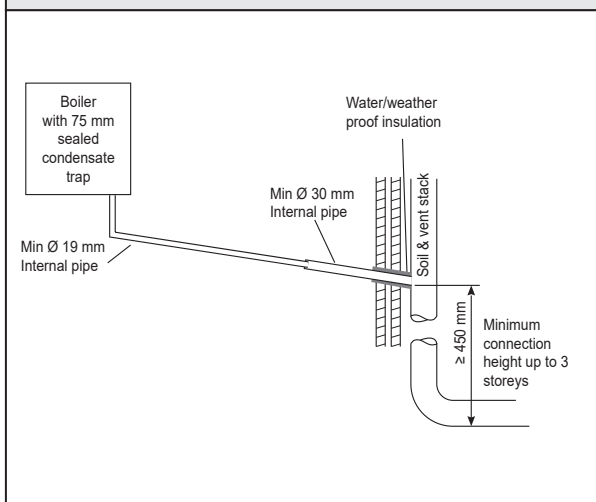

**Figure 5 - Connection of a Condensate Drainage Pipe to an External Rainwater Downpipe (only combined foul/rainwater drain)**

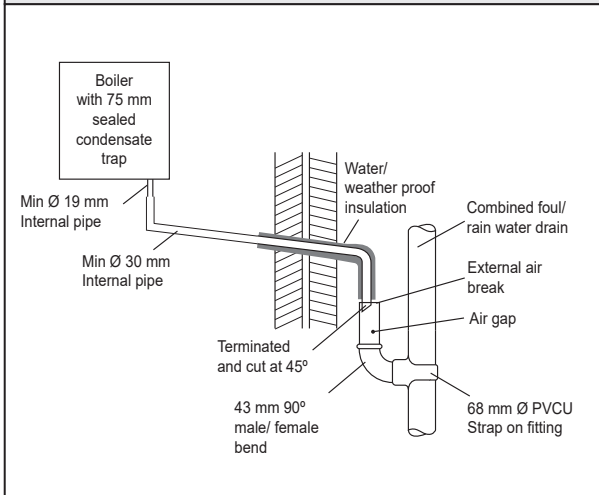

**Figure 6 - Connection of a Condensate Drainage Pipe to an External Purpose Made Soakaway.**

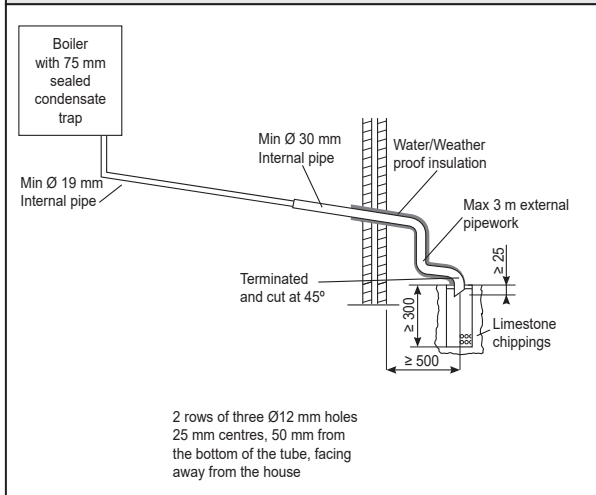

## 2.17 CONNECTIONS & FILLING

**CAUTION:** Heating the isolation valves may damage the fibre seals

Remove all boss blanking plugs before connecting the hardware.

Fit each union with the fibre seals provided.

### WATER CONNECTIONS CH

1. Connect the CH flow service valve (black handle) and copper tail provided in the hardware pack to the threaded boss connection provided at the lower rear of the boiler.
2. Connect the CH return valve (black handle) and copper tail.

### GAS CONNECTION

**CAUTION:** The gas service cock is sealed with a non-metallic blue fibre washer, which must not be overheated when making capillary connections.

For details of the position of the gas connection:

### PRV DRAIN

The PRV connection, located at the bottom right-hand side of the boiler comprises an open ended 15 mm pipe.

A 15mm compression coupling should be fitted to assist in removal of pipework if required.

**WARNING:** Make sure that the water or steam (from the boiler) is discharged safely. Hot water or steam is dangerous and can cause serious injury, and damage to electrical systems.

A purpose made PRV drain pipe is provided with the boiler to allow safe discharge through a wall to the outside of the building. This is particularly relevant to 'high rise' installations but can be used for all installations.

If a secondary PRV is required then the correct Logic2 Secondary PRV kit must be used and fitted correctly.

### FILLING

#### IMPORTANT - when filling:

- A. All electrical connections must be protected from water leakage.
  - B. Fully open the Pump Automatic Air Vent. If there is a leakage of water, then the Automatic Air Vent must be replaced. (Refer to Section 3.20, Pump Auto Air Vent Replacement).
1. Ensure that the CH isolating handles are open.
  2. Fill and vent the system.
  3. Check for water soundness.

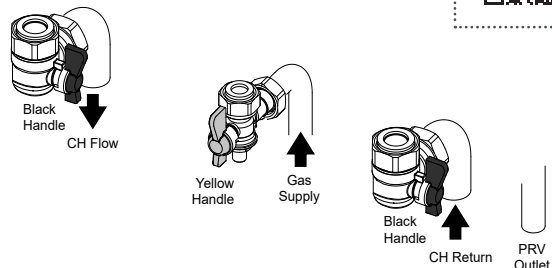
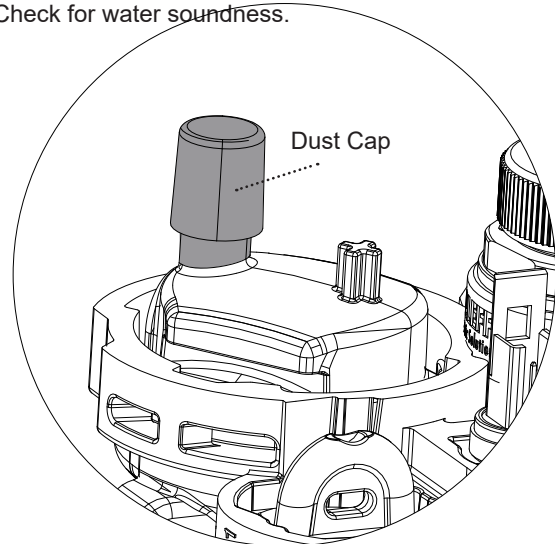

## 2.18 ELECTRICAL CONNECTIONS

**WARNING:** This appliance must be earthed

A mains supply of 230 V ~ 50 Hz is required.

3 A fuse required. All external controls and wiring must be suitable for mains voltage.

Wiring external to the boiler must follow current IET (BS7671) wiring regulations and local regulations.

Wiring should be 3 core PVC insulated cable, not less than 0.75 mm<sup>2</sup> (24 x 0.2 mm), and to BS EN 50525-1:2011 Table 16.

Connection must be made in a way that allows complete isolation of the electrical supply. The means of isolation must be accessible to the user after installation.

## 2.19 INSTALLER WIRING

**WARNING:** Ensure the supply cord is not damaged

The boiler must be connected to a permanent live power supply.

### Connecting the Switched Live to the Boiler

1. Consult the Y Plan and S Plan diagrams overleaf.
2. Isolate the mains supply to the boiler.
3. Remove the front panel.

Refer to Section 3.4

4. Swing down the control box into the service position, unclip and swing back the installer wiring cover and latch into the retaining clips.

All of the connections can now be readily accessed.

5. Connect the switched live to the terminal block as shown.
 

**Note.** The cable strain relief system and grommets.
6. Once any wiring is completed, to secure the boiler, reverse the order above.

### Frost Thermostat – Wiring

If parts of the system are vulnerable to freezing or the programmer is likely to be left off during cold weather, a frost stat should be fitted in conjunction with a pipe thermostat.

Installer Connections (LHS)

Installer Connections (RHS)

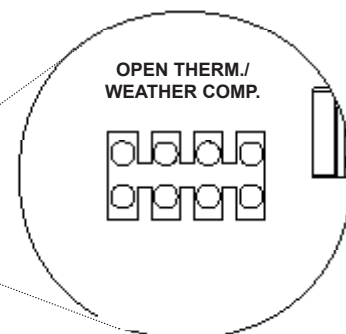
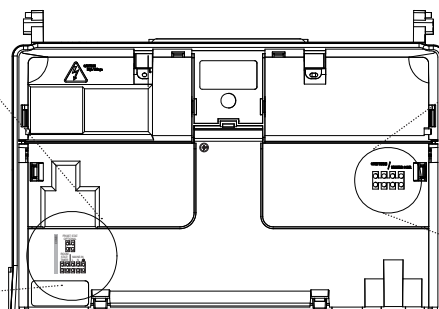
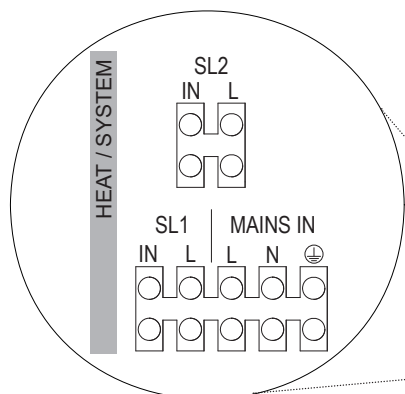
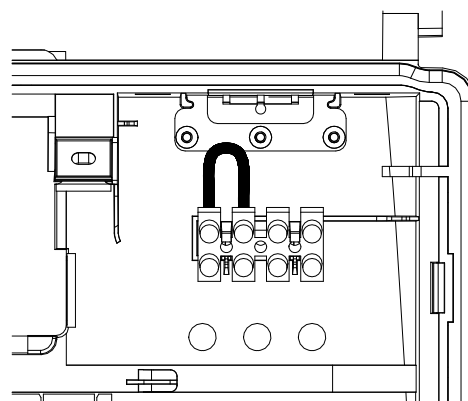
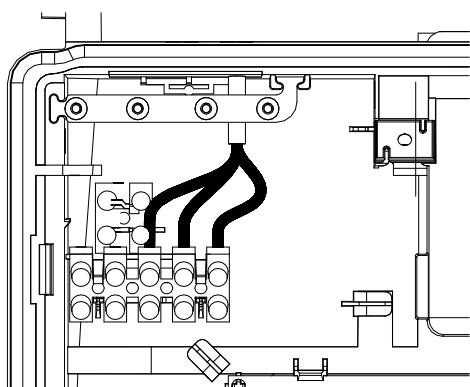

2.20 INSTALLER WIRING - CONTINUED

**Logic System<sup>2</sup> S BOILER WITH Y PLAN SYSTEM**

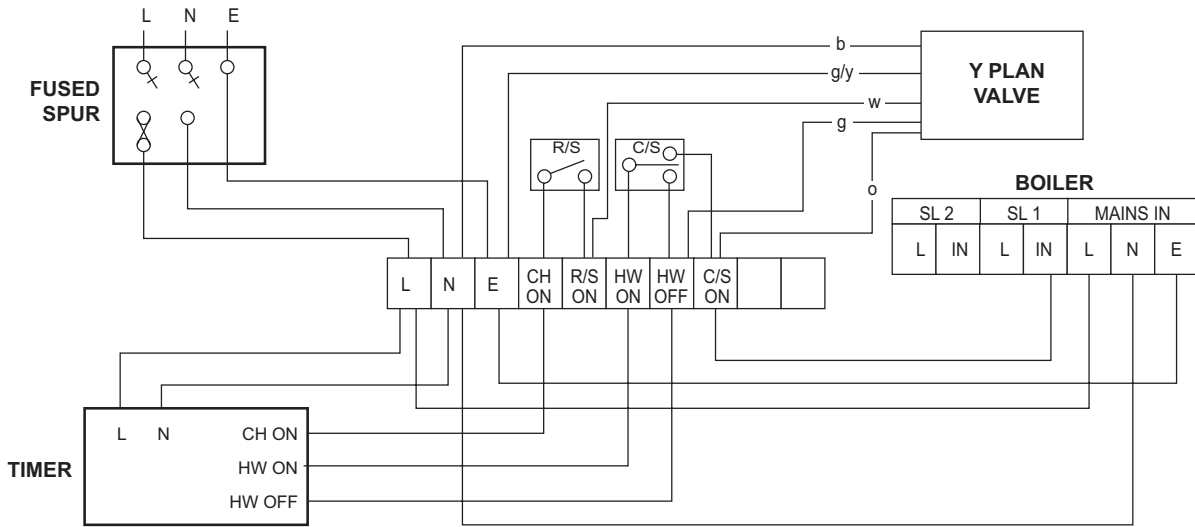

**Logic System<sup>2</sup> S BOILER WITH S PLAN SYSTEM**

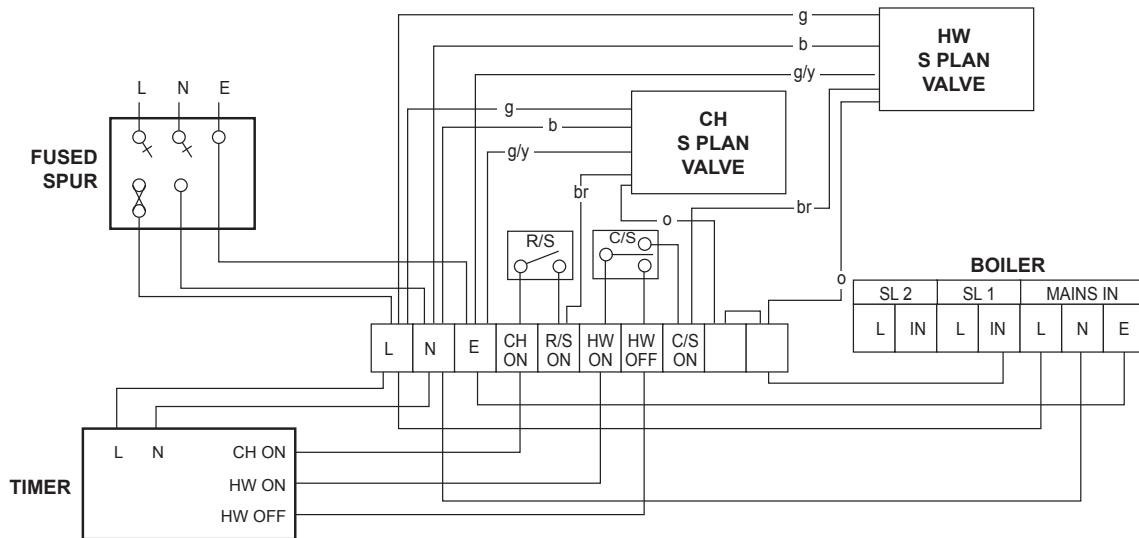

2.21 INSTALLER WIRING - CONTINUED

**Logic System<sup>2</sup> S BOILER WITH Y PLAN SYSTEM (with outside sensor OR 2x Switched Live Operation)**

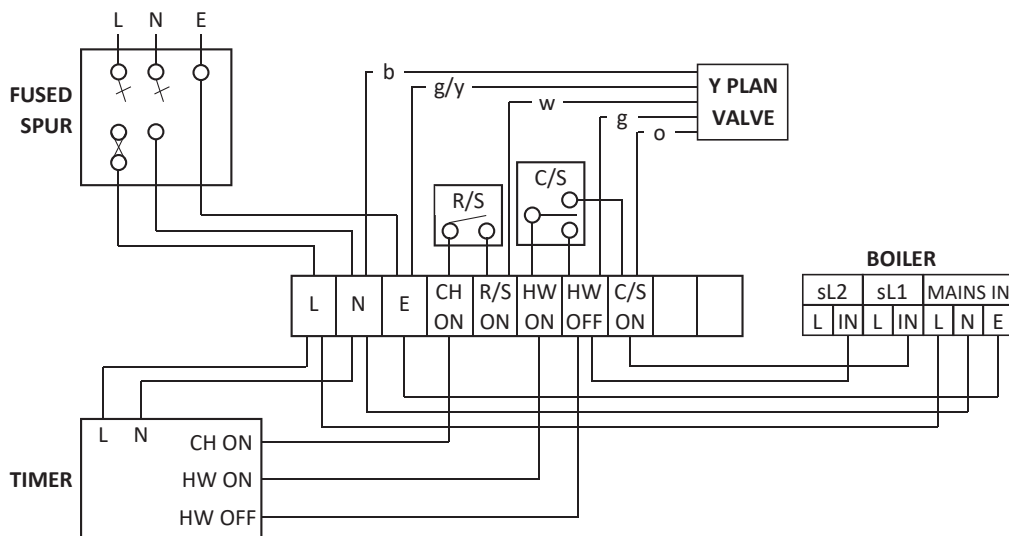

**Logic System<sup>2</sup> S BOILER WITH S PLAN SYSTEM (with outside sensor OR 2x Switched Live Operation)**

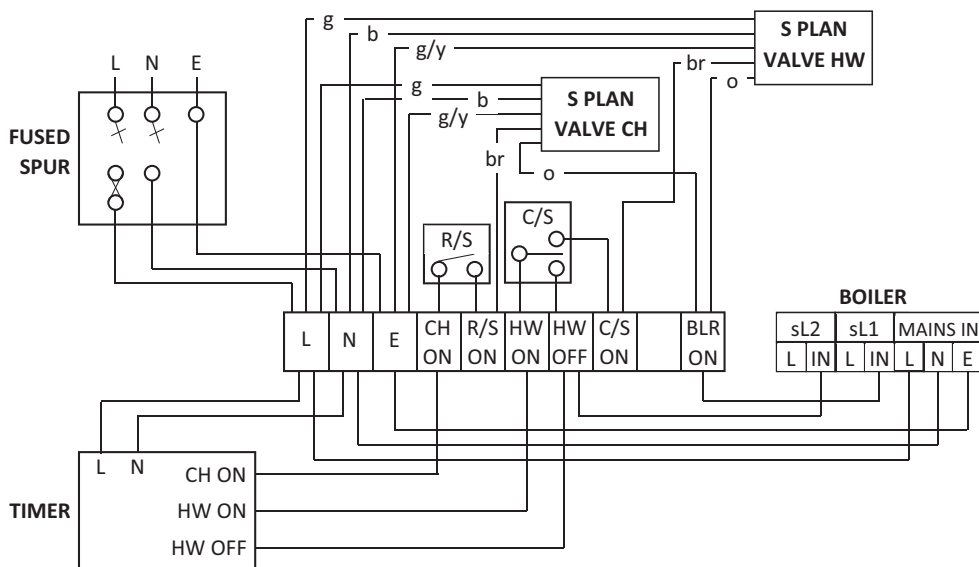

## 2.22 REPLACING PRE-FITTED MAINS CABLE

If it is necessary to use an alternative mains cable to the one pre-fitted then use the following guide.

Replacement wiring should comply with notes in Section 2.18 & 2.19 and be carried out by a qualified person.

1. Isolate the mains supply to the boiler.
2. Remove the front panel.
3. Swing the control box down into the service position, unclip and swing back the installer wiring cover to latch into the retaining clips.
4. Unscrew the L N & E connections & remove wires from connector.
5. Remove the mains cable by pulling back through the grommet .
6. Route the replacement through the grommet and re-fit in reverse order.
7. Close the installer wiring cover ensuring that it is located correctly and that the cable is retained into the strain relief as shown.

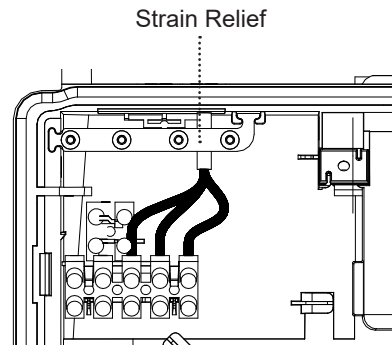

8. Swing the control box back up into the operating position and re-fit the front panel ensuring a good seal is made.

The earth connection should be longer than the current carrying connections. If the cord anchorage slips, the current carrying wires become taut before the earth.

## 2.23 EXTERNAL ELECTRICAL CONTROLS

### Wiring External to the Boiler

The fuse rating should be 3 A.

Wiring external to the boiler **MUST** be in accordance with the current IET (BS.7671) Wiring Regulations and any local regulations.

### Frost Protection

If parts of the pipework run outside the house or if the boiler will be left off for more than a day or so then a frost thermostat should be wired into the system.

The frost thermostat should be sited in a cold place but where it can sense heat from the system.

If the boiler is installed in a garage it may be necessary to fit a pipe thermostat, preferably on the return pipework.

### EXAMPLE - Connection to Honeywell Evohome

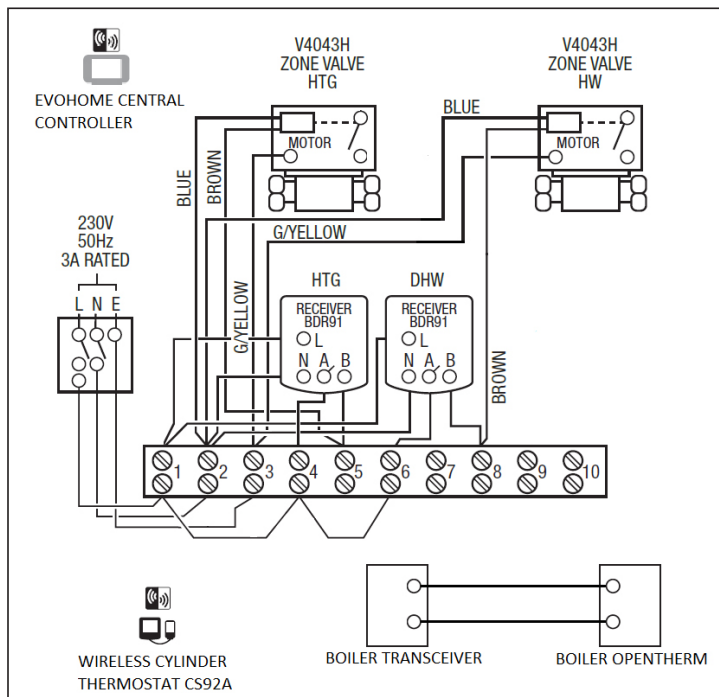

### 2x Switched Live Operation

For a boiler without an Outside Sensor connected, it can be set to operate with 2x Switched Live control via the menu.

When this feature is turned on:

- sL1 is the CH/DHW demand input:
  - 0V = CH/DHW demand **Off**, 240V = CH/DHW demand **On**
- sL2 becomes the DHW demand input:
  - 0V = DHW demand **On**, 240V = DHW demand **Off**

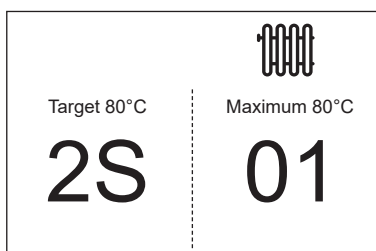

1x Switched Live Mode selected.

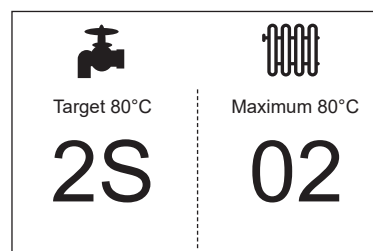

2x Switched Live Mode selected.



## 2.25 COMMISSIONING AND TESTING

### A. Electrical Installation

**WARNING:** Electrical safety checks should be carried out by a qualified person.

Complete preliminary electrical system checks.

#### General

The combustion for this appliance has been checked, adjusted and preset at the factory for operation on the gas type defined on the appliance data plate.

Do not adjust the air / gas ratio valve.

Check the following:

1. The boiler has been installed in accordance with these instructions.
2. The integrity of the flue system and the flue seals, as described in the Flue Installation Section.

Proceed to put the boiler into operation as follows:

1. Check the operational gas inlet pressure.
2. Set up the boiler to operate at maximum rate. See page 60.
3. With the boiler operating in the maximum rate condition check that the operational gas pressure at the inlet gas pressure test point complies with the requirements.
4. Ensure that this inlet pressure can be obtained with all other gas appliances in the property working.

Refer to Gas Supply  
page 10

### Intelligent Load Optimisation

Intelligent Load Optimisation is a feature enabled on the boiler to reduce cycling on and off and behaves as follows.

With an active CH demand (e.g. Switched Live on), if the Flow Temperature reaches the CH Target + 4°C then the boiler switches off and the Intelligent Load Optimisation function is activated. This can happen if the system load is less than the minimum output of the boiler.

If the CH demand is still active, when the boiler lights again it immediately modulates down to the minimum rate over 60s and then stays at the minimum for 10 minutes.

Normal operation resumes after either of the following conditions are met:

- After 10 minutes of operation at minimum rate.
- The CH demand is off for more than 1 hour.

**IMPORTANT:** A condition of the manufacturer's warranty is that Benchmark commissioning process is completed.

Refer to Flow Chart  
Page 61

### B. Gas Installation

**WARNING:** Open windows, doors and extinguish flames before starting the next steps. Do not smoke.

1. The whole of the gas installation, including the meter, should be inspected and tested for tightness and purged in accordance with the recommendations of BS.6891.
2. Purge air from the gas installation by the approved methods only.

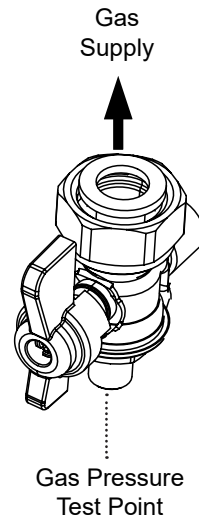

## 2.26 INITIAL LIGHTING

### Legend

- A. Temperature Knob
- B. Mode Button
- C. Boiler Status Display
- D. Burner On indicator
- E. Restart Button
- F. CH Flow Isolating Valve
- G. System Pressure Gauge
- H. Gas Inlet Pressure Test point
- J. Gas Service cock
- K. CH Return isolating valve
- L. PRV Drain

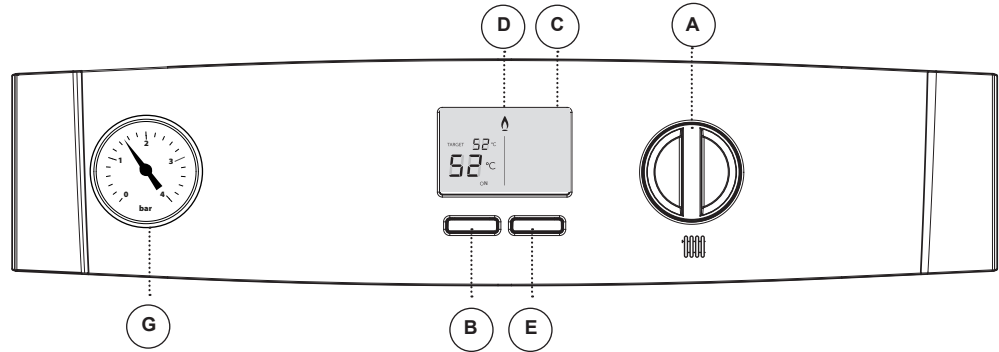

**IMPORTANT** Do not operate the appliance before it has been fully vented of air. If it is necessary to operate the pump, do so with the gas service cock turned off.

The boiler incorporates a fan overrun cycle which must not be interrupted by isolation of electricity supply.

1. Check that the system has been filled and that the boiler is not airlocked.
2. Refit the boiler front panel.

Refer to Section 3.4

3. Check that the drain valve is closed and that the CH isolating valves (F & K) are OPEN.
4. Press the Mode button until Off is shown at the bottom of the screen (Boiler off).
5. Switch the electrical supply OFF
6. Check that the gas service cock (J) is OPEN.
7. Slacken the screw in the inlet pressure test point (H) and connect a gas pressure gauge via a flexible tube.
8. Switch the electricity supply ON and check all external controls are calling for heat.

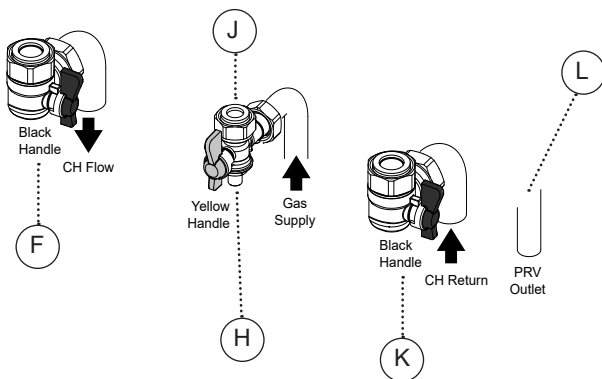

### CENTRAL HEATING

9. Press the Mode Button (B) until On is shown at the bottom of the screen. Turn the Temperature Knob clockwise until a target of 80°C is shown on the smaller digits. The boiler control will now go through its ignition sequence until the burner is established.
10. If the boiler does not light then after 5 attempts the boiler will lock out and display fault code L 02. Press the Restart Button (E). The boiler will repeat its ignition sequence. If Restart occurs 5 times within 15 minutes then L 0C will be shown.

When the burner is established the flame symbol (D) will be shown on the display and the current flow temperature will be shown in the large digits.

11. Ensure that with the boiler operating, the dynamic gas pressure is able to obtain maximum output. Refer to Table 2.

### IMPORTANT

The gas input to the burner is regulated by the gas valve according to the air flow produced by the fan. It is not user-adjustable. Any interference to sealed settings on the gas valve will adversely affect operation and render our warranty void.

Refer to Gas Supply page 10

12. Remove gas pressure gauge, tighten inlet pressure test point and check for gas tightness.

## 2.27 THE DISPLAY

The user control has one display to inform the user about the status of the boiler. The display shows the status of the flame. If no flame is detected then flame symbol will not be visible. When the flame is detected the flame symbol will be visible permanently.

Below is a list with display function.

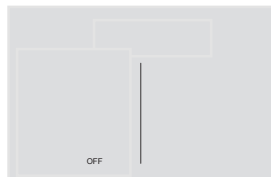

### Boiler Off Mode

Press the Mode button to enable CH.



### Boiler On Mode, no Heat Demand

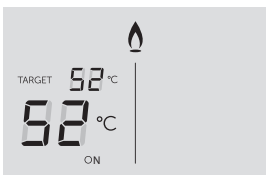

### Boiler is active for Central Heating

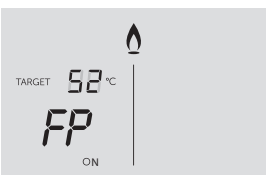

**Boiler is active for boiler frost protection:** operates if the ambient temperature is below 5°C until it reaches 19°C.

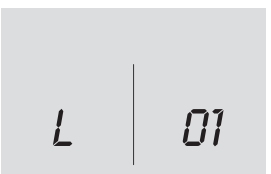

**Boiler is in Lockout for a specific error.** Display will show a number after the "L" to indicate which error is detected

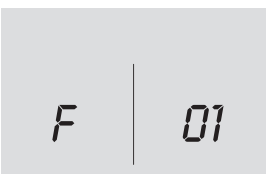

**Boiler has a fault for a specific error.** Display will show a number after the "F" to indicate which error is detected.

## 2.28 GENERAL CHECKS

**Make the following checks for correct operation:**

### CENTRAL HEATING (CH)

1. Ensure that the external controls are calling for heat. The display should show:-

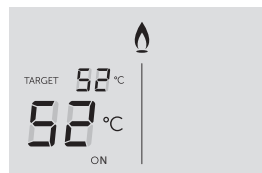

### 2. Gas Rate

Check the boiler gas rate when the boiler is at maximum output.

Refer to Section 2.31

Check at the gas meter, with no other appliance in use. Refer to Table 2 for gas rates.

3. Set the external controls to OFF. The burner should go off and the pump continue to run for 4 minutes.

The display should show:



4. Check the correct operation of the timer (if fitted) and all other system controls. Operate each control separately and check that the main burner responds.

## 2.29 GENERAL CHECKS - WATER CIRCULATION

### WATER CIRCULATION SYSTEM

1. With the system cold, check that the initial pressure is correct to the system design requirements.  
For pre-pressurised systems, this should be 1.0 bar.
2. With the system hot, examine all water connections for soundness. The system pressure will increase with temperature rise but should not exceed 2.5 bar.
3. With the system still hot, turn off the gas, water and electricity supplies to the boiler and drain down to complete the flushing process.

**Note.** A flushing solution should be used during the flushing procedure. Flushing solutions: Fernox Superfloc, Sentinel X300 (new systems) or X400 (existing systems).

Refer to Section  
**1.18**

4. Refill and vent the system, add inhibitor.

Refer to Section  
**1.16**

Clear all air locks and again check for water soundness.

5. Reset the system initial pressure to the design requirement.
6. Balance the system.

Refer to Section  
**1.17**

7. Check the condensate drain for leaks and check that it is discharging correctly.
8. Finally, set the controls to the User's requirements.

**Note** The pump will operate briefly as a self-check once every 24 hours in the absence of any system demand.

### WATER TEMPERATURES

Temperatures can be selected using the Temperature Knob (A)

| Temperature Knob Setting | CH Flow Temp °C |
|--------------------------|-----------------|
| Max                      | 80              |
| Min                      | 30              |

## 2.30 RESTART PROCEDURE

### Legend

- A. Temperature Knob
- B. Mode Button
- C. Boiler Status Display
- D. Burner On indicator
- E. Restart Button
- F. System Pressure Gauge

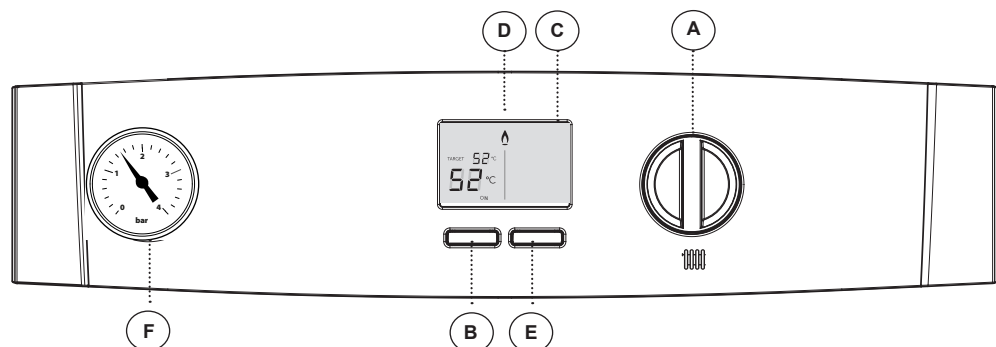

If an L code is shown on the display then the boiler can be restarted by pressing the Restart button (E).

## 2.31 ACCESSING THE INSTALLER MODE

To access Installer Mode, press the "MODE" and "RESTART" buttons together for more than 5s.

1. The last 3 faults will be shown. See Frame 4.1 for Fault Code descriptions.

2. "SH" will be shown.

To run the burner at maximum rate press "RESTART", otherwise press "MODE".

3. "SL" will be shown.

To run the burner at minimum rate press "RESTART", otherwise press "MODE". Note that the burner will initially run at maximum rate for 30s before ramping down to minimum over 1 minute.

4. "UF" will be shown.

To activate the Venting function press "RESTART", otherwise press "MODE". The Venting function runs for 5 minutes before automatically returning to normal operation. The pump alternates between being on for 50s and then off for 10s.

5. "P1" will be shown.

To set the minimum CH pump speed to 100% press "RESTART", otherwise press "MODE".

6. "P7" will be shown.

To set the minimum CH pump speed to 70% press "RESTART", otherwise press "MODE".

7. "SE" will be shown.

For service timer function refer to separate instructions. Press "MODE" to exit.

8. "5E" will be shown.

For service timer function refer to separate instructions. Press "MODE" to exit.

## 2.32 HANDING OVER

**After completing the installation and commissioning of the system the installer should hand over to the householder by the following actions:**

1. Hand the User Instructions to the householder and explain his/her responsibilities under the relevant national regulations.
2. Explain and demonstrate the lighting and shutting down procedures.
3. The operation of the boiler and the use and adjustment of all system controls should be fully explained to the householder, to ensure the greatest possible fuel economy consistent with the householder requirements of both heating and hot water consumption. Advise the user of the precautions necessary to prevent damage to the system and to the building. In the event of the system remaining inoperative during frosty conditions.
4. Explain the function and the use of the boiler heating and domestic hot water controls.
5. Explain the function of the boiler fault mode. Emphasise that if a fault is indicated refer to "Fault Codes" in the User Guide.
6. Explain and demonstrate the function of timers and temperature controls, radiator valves etc. for the economic use of the system.
7. Loss of system water pressure.

Explain that the dial on the control panel front indicates the central heating system pressure and that if the normal COLD pressure of the system is seen to decrease over a period of time then a water leak is indicated. Explain the re-pressurising procedure and if unable to re-pressurise or if the pressure continues to drop a registered local heating installer should be consulted.

Refer to Section  
2.17

8. Explain boiler restart procedure.

Refer to Section  
2.30

9. After installation and commissioning please complete the Commissioning Checklist before handover to the customer.



Refer to  
page 58

### ! IMPORTANT:

10. A comprehensive service should be carried out ANUALLY. Stress the importance of regular servicing by a Gas Safe Registered Engineer.
11. Inform the householder of the guarantee/registration found within the envelope pack and then requirement to register it to receive the full benefit of the warranty.

## 3.1 SERVICING SCHEDULE



**WARNING:** Servicing can only be carried out by Gas Safe Registered Engineers. Always turn OFF the gas supply at the gas service cock, and switch OFF and disconnect the electricity supply to the appliance before servicing.  
**Combustion testing must be carried out by a competent person using a combustion analyser conforming to BS EN 50379-3 2012.**

To ensure the continued safe and efficient operation of the appliance it is recommended that it is checked at regular intervals and serviced as necessary. The frequency of servicing will depend upon the installation condition and usage but should be carried out at least annually.

For the latest copy of literature for specification & maintenance practices, visit [idealheating.com](http://idealheating.com).

### PRELIMINARY INSPECTION

1. Light the boiler and carry out a pre-service check, noting any operational faults (refer to appropriate fault finding chart as necessary).
2. Check the flue terminal (and terminal guard if fitted) is undamaged and clear of any obstruction.
3. Check combustion by connecting the flue gas analyser to the flue gas sampling point as shown in the diagram and measure CO and CO<sub>2</sub> at maximum rate. To set the boiler to Maximum and Minimum heat inputs:

Refer to  
Page 60

Repeat at minimum rate.

If the CO / CO<sub>2</sub> ratio is greater than 0.004 please proceed to "Cleaning Procedure".

If the CO / CO<sub>2</sub> ratio is less than 0.004 please proceed to "Check Procedure".

### CHECK PROCEDURE

1. Check all water and gas joints for signs of leakage. Remake any suspect joints ensuring a gas tightness check is carried out if applicable and the water system is correctly refilled, vented and re-pressurised.
2. Proceed to "IMPORTANT".

### IMPORTANT

1. If, for any reason, the condensate trap has been removed, ensure the trap is refilled with water before re-assembling.
2. After completing the servicing or exchange of components always ensure all gas valve connections are gas tight with a gas soundness check up to the gas control valve.
3. When work is complete the front panel MUST be correctly refitted, ensuring that a good seal is made.
4. Complete the service section in the Benchmark Commissioning Checklist.

### GENERAL

During Servicing, and after any maintenance or change of part of the combustion circuit, the following must be checked:

- The integrity of the flue system and the flue seals.
- The integrity of the boiler combustion circuit and the relevant seals.
- The operational (working) gas inlet pressure at maximum rate.
- The gas rate.
- The combustion performance.

### CLEANING PROCEDURE

1. Remove the casing.
2. Visually check the appliance for signs of leakage.
3. Remove the flue manifold.
4. Remove the fan.
5. Remove the burner.
6. Refit the sump outlet cover.
7. Clean the heat exchanger by pouring warm water across the whole heat engine to flush deposits taking care to avoid pouring water over the electrode.
8. Check the electrode for damage and clean using an abrasive cloth. Check and adjust the spark gap. Replace the electrode if damaged.
9. Clean out the sump outlet to ensure any debris is removed.
10. Remove and clean the condensate trap and re-prime the trap before re-installing.
11. Re-assemble the components in reverse order.
12. Carry out post service checks on the combustion circuit. See General.
13. Check the system water quality in accordance with BS7593:2019.
14. Complete the service record in the Benchmark section.

**Do not operate the boiler if the front panel is not fitted.**

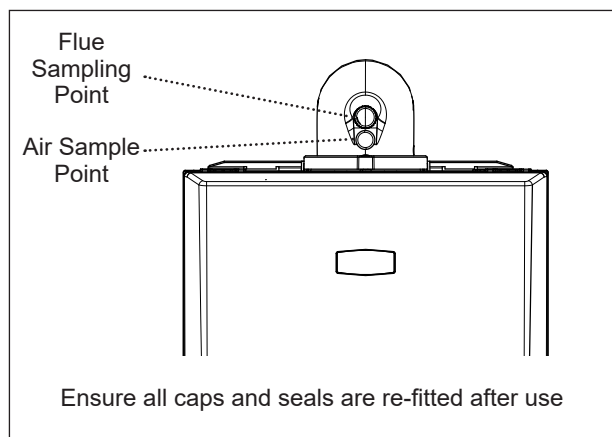

## 3.2 REMOVAL / REPLACEMENT OF COMPONENTS

**WARNING:** Do not operate the boiler without a front panel fitted

### When replacing any component.

1. Isolate the electricity supply.
2. Turn off the gas supply.
3. Remove the boiler front panel.
4. Swing the control box down into its servicing position.

### After removing / replacing any component.

5. Ensure all gas valve connections are gas tight with a gas soundness check up to the gas control valve.
6. Ensure all water connections are tight.

7. Test the appliance for correct and safe operation.

Refer to Section 2.28

### Notes.

1. In order to assist fault finding, the control panel has an LCD diagnostic display. The key to boiler fault conditions is shown in Section 4.
2. In order to replace components in Sections 3.11 and 3.18-3.25, it is necessary to drain the boiler.

Refer to Section 3.3

## 3.3 DRAINING THE BOILER

### CENTRAL HEATING CIRCUIT

1. Close all the CH water isolating valves on both the flow and return.
2. To drain the primary heat exchanger circuit: Open the drain valve and attach a length of hose to the CH drain point.
3. After replacing any component on the boiler, remove the hose, close the drain valve and open all system isolating valves.
4. Repressurise and check operation of the boiler.

Refer to Section 2.17

5. Check that the boiler operates.

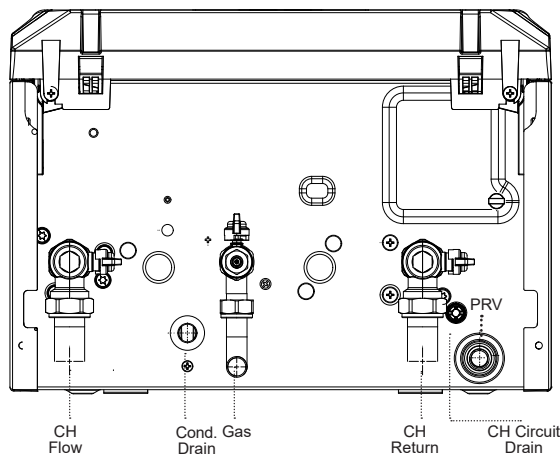

## 3.4 BOILER FRONT PANEL REMOVAL / REPLACEMENT

### REMOVAL

1. Loosen the two screws retaining the front panel.
2. Pull the two clips down to disengage and pull panel forward and upward and remove.

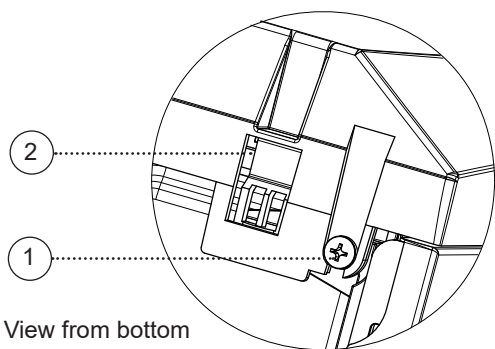

View from bottom of boiler

### REPLACEMENT

3. Hook the panel onto the top retaining clips.
4. Push the panel until the 2 bottom spring clips engage ensuring the 1 knob and 2 buttons line up with the holes in the front panel.
5. Re-tighten the two retaining screws.

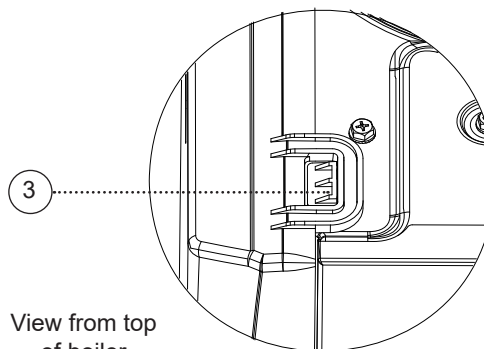

View from top of boiler

## 3.5 FLUE MANIFOLD REMOVAL/REPLACEMENT

1. Remove the two sump cover retaining screws.
2. Remove the sump cover.
3. Lift the manifold upwards to clear the sump.
4. Move the manifold to the left and pull down to remove.

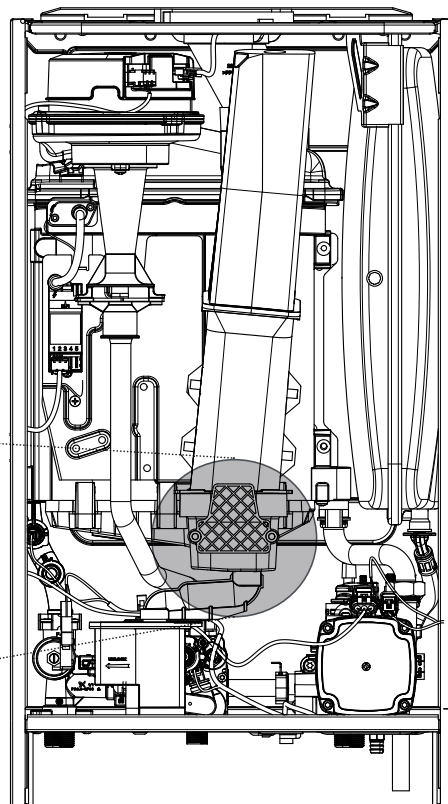
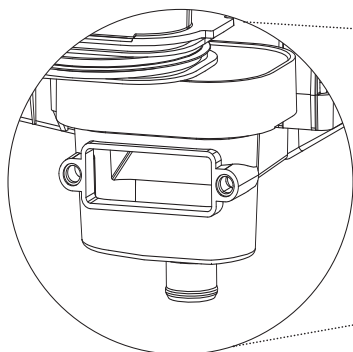

## 3.6 BURNER REMOVAL AND CLEANING

Refer to Section 3.2

1. Remove the 2 burner front fixing screws and the 2 rear extended nuts.
2. Lift and pull forward the burner from the combustion chamber by holding the burner with two finger in the air inlet duct and your thumb on the top of the burner.
3. Tilt the burner towards yourself so that it raises to the vertical position.

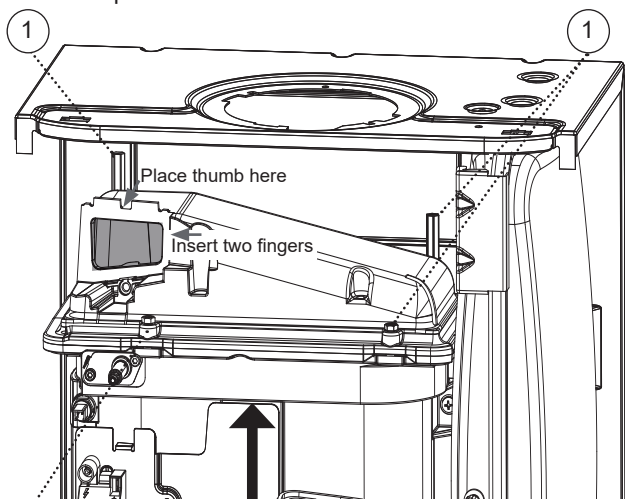

Lift the burner approximately 5 to 10 mm from the heat engine and then pull forward by the same amount.

4. Pull the burner out from the left hand side of the boiler once it is in the vertical position.

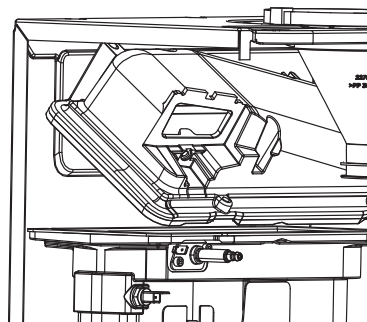

5. Carefully brush the ceramic burner with a soft non metallic bristle brush.

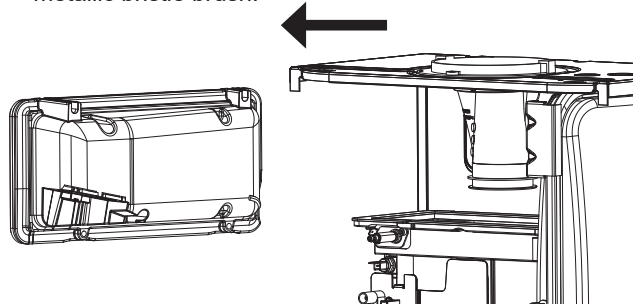

### 3.7 FAN AND VENTURI ASSEMBLY REMOVAL AND CLEANING

1. Disconnect the electrical leads from the fan.
2. Remove the clip from the gas control valve outlet and ease the pipe upwards. Rotate and then ease down to remove.
3. Remove the extended nut on the fan mounting bracket.
4. Lift off fan and venturi assembly.
5. Undo the two M4 screws and release the nozzle assembly.
6. Inspect the injector for blockage or damage.
7. Clean the outside of the injector and use a small flue brush to clean the injector hole. Do not use anything abrasive such as a file.
8. Remove the screw and twist venturi anti-clockwise to remove venturi assembly, noting the orientation of the venturi in relation to the fan body.
9. Inspect fan outlet sealing gasket and replace if necessary.
10. Ensure the venturi is free from dust/debris.
11. Check the 'O'-rings are fitted correctly to the gas outlet pipe replacing if any damage is witnessed.

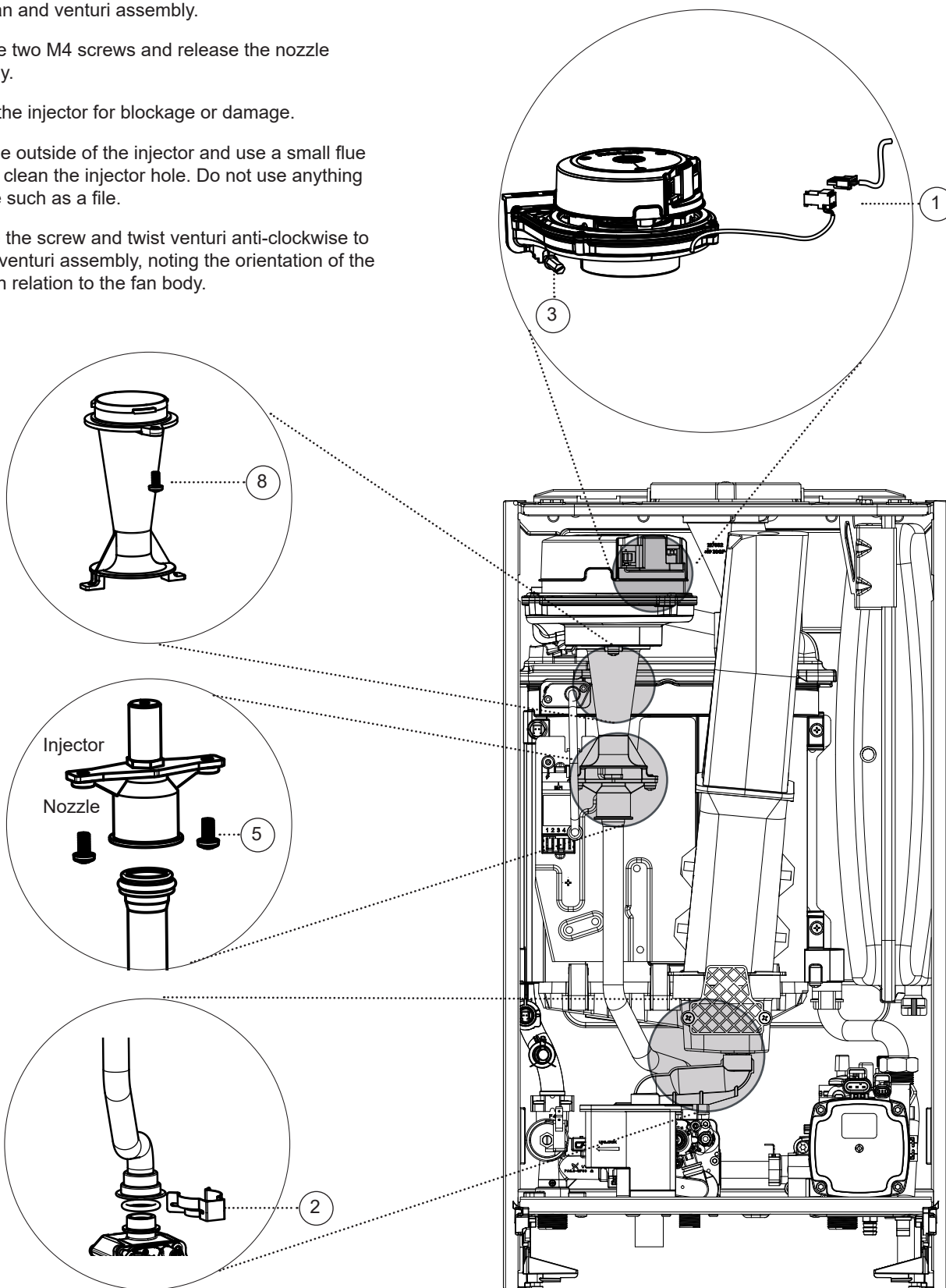

## 3.8 CLEANING THE HEAT EXCHANGER

1. Ensure the condensate trap is fully drained before cleaning.

Refer to Section  
3.10

2. Remove ignition/detection electrode.

Refer to Section  
3.9

3. Replace the sump cover prior to the water flush process.
4. Thoroughly flush the heat exchanger by pouring water into the top of the combustion chamber ensuring the full top area is covered.
5. Remove the sump cover and clean loose deposits from the sump.

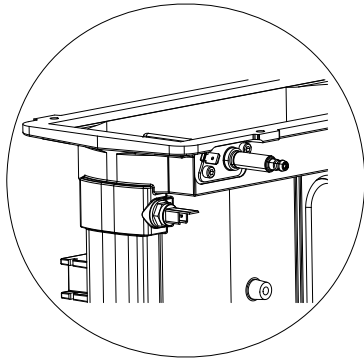

Combined Ignition Detection Electrode

6. Inspect the ignition/detection electrode. Ensure that they are clean and in good condition - replace if necessary.
7. Re-fit the ignition/detection electrode, ensuring that the earth tab is fitted to the ignition electrode.
8. Check that the ignition gap is correct.

Refer to Section  
3.9

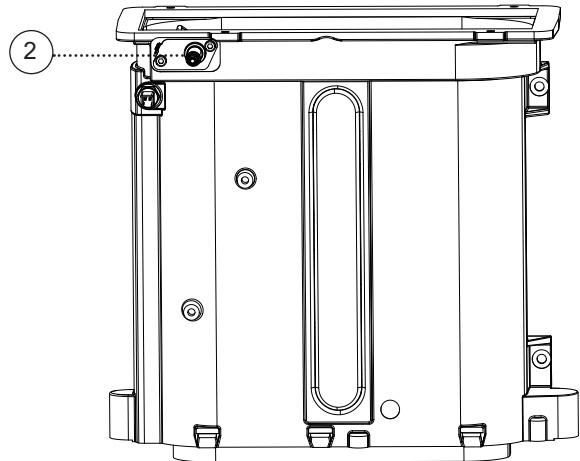

## 3.9 IGNITION / DETECTION ELECTRODE REPLACEMENT / INSPECTION

Refer to Section  
3.2

1. Remove the fan.

Refer to Section  
3.7

2. Remove the flue manifold.

Refer to Section  
3.5

3. Remove the burner.

Refer to Section  
3.6

4. When servicing the boiler inspect the condition of the electrode and check the dimensions shown. If there is damage to the electrode continue to follow steps below for replacement.
5. Unplug the ignition lead from the electrode.
6. Remove the earth lead from the electrode.
7. Remove the 2 screws holding the electrode to the combustion chamber.
8. Remove the electrode.
9. Fit the new electrode, using the new gasket supplied. Check dimensions as shown.

Refer to Section  
2.28

Ignition /Detection  
Electrode

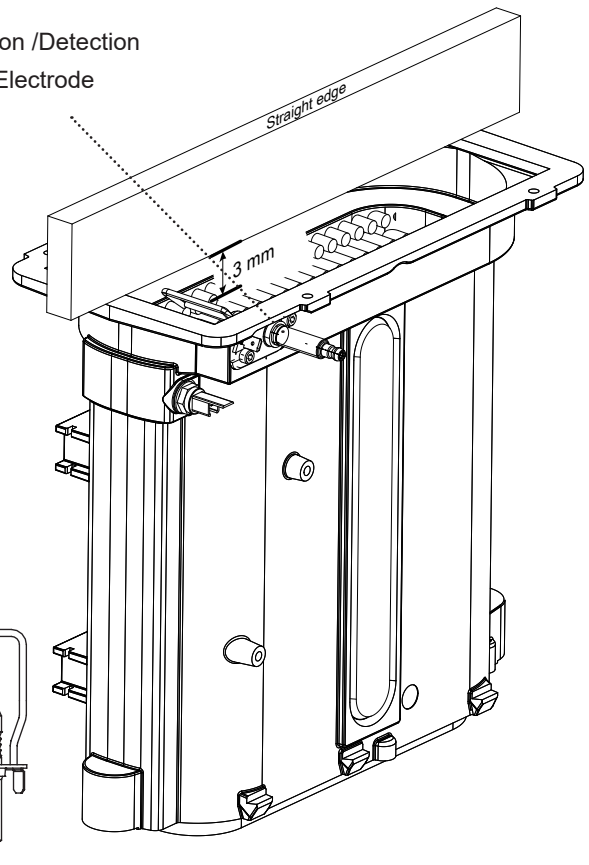

## 3.10 CLEANING / REPLACING THE CONDENSATE TRAP

SCAN

for video



**CAUTION:** Keep trap upright when removing

1. Pull off the rubber pipe at the sump drain.
2. Disconnect the condensate drain pipe.

3. Turn the trap clockwise to disengage and lift to remove.
4. Clean and fill trap with water.

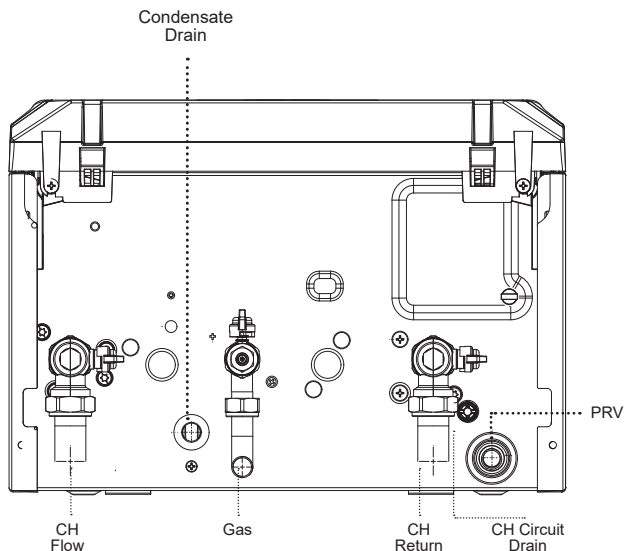
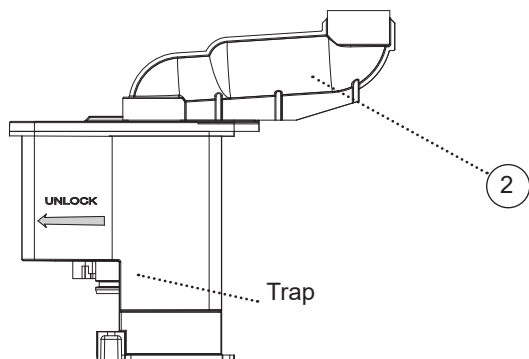

## 3.11 RETURN THERMISTOR REPLACEMENT

Refer to Section 3.2

1. Isolate and drain down the boiler.
2. Remove the clip from the pump housing and remove the thermistor.
3. Disconnect the electrical lead from the thermistor.
4. Reconnect the electrical lead to the new thermistor and reassemble, ensuring that the thermistor is fully engaged and the clip is correctly located.
5. Check the operation of the boiler.

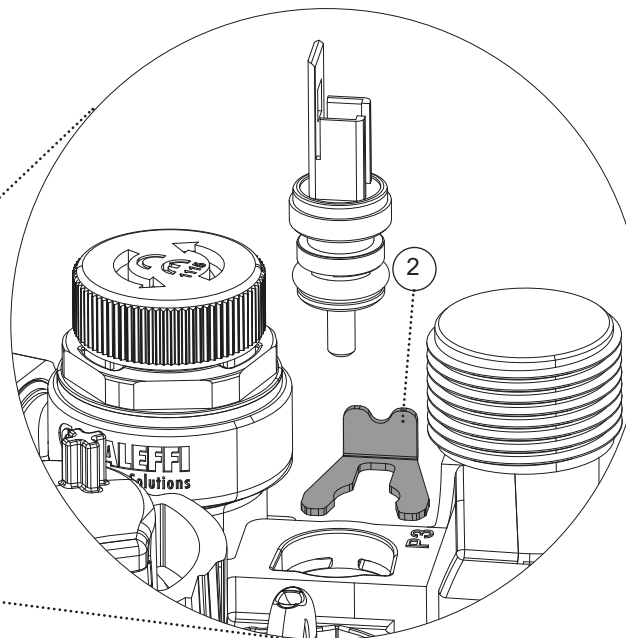
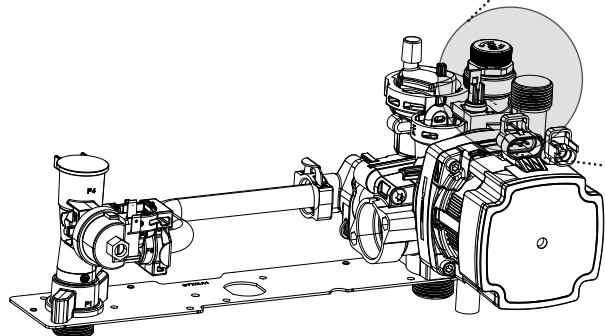

## 3.12 BURNER INJECTOR REPLACEMENT

Refer to Section 3.67

## 3.13 BURNER REPLACEMENT

SCAN  
for video



Refer to Section  
3.2 & 3.6

## 3.14 SPARK GENERATOR REPLACEMENT

Refer to Section  
3.2

1. Disconnect the leads from the spark generator.
2. Gently push up the generator to release the bottom clip from the gas valve mounting bracket.
3. Lift the spark generator up and out of the bottom retaining location point.
4. Fit the new spark generator and re-assemble ensuring that the the earth lead is replaced.
5. Check the operation of the boiler.

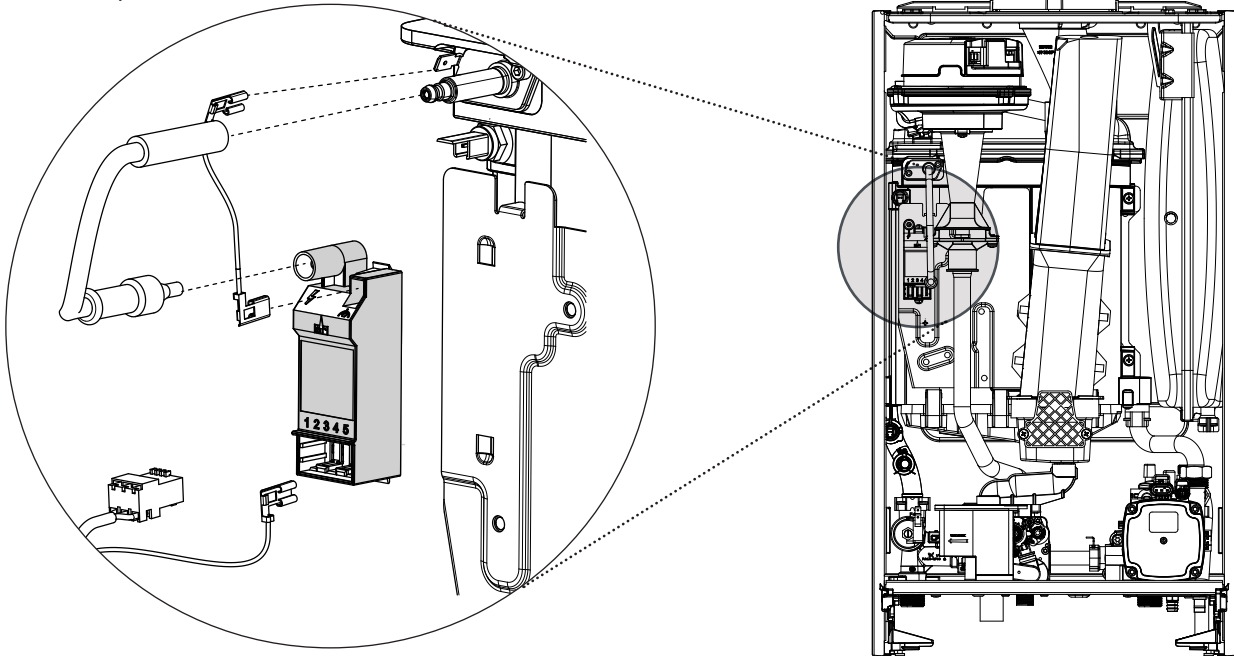

## 3.15 GAS CONTROL VALVE REPLACEMENT

Refer to Section  
3.2

1. Disconnect and remove the trap and rubber connector.

Refer to Section  
3.10

2. Unplug the electrical lead connection from the gas control valve.
3. Remove the outlet gas valve clip and slide the pipe upwards.
4. Undo the gas inlet pipe union at the inlet to the gas valve.
5. Undo the two screws fixing the gas valve to the chassis base and lift the gas valve upwards.
6. Fit the new gas control valve ensuring that the 'O' ring and sealing washer are in place and reconnect gas and electrical connections.
7. Refit the trap.
8. Ensure all gas valve connections are gas tight with a gas soundness check up to the gas control valve.
9. Check the operation of the boiler.

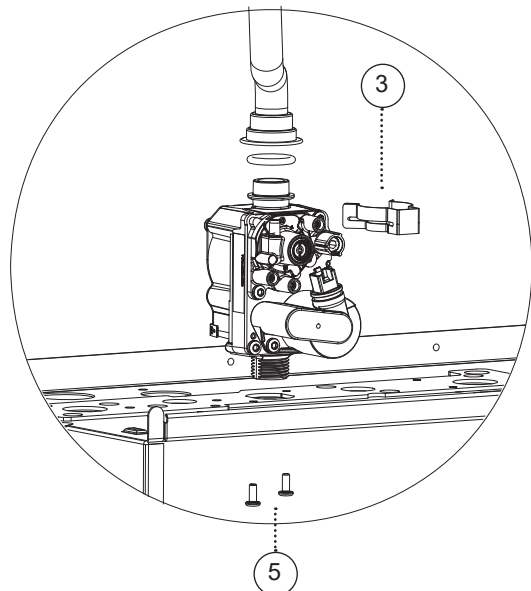

## 3.16 CONDENSATE TRAP REPLACEMENT / CLEANING

Refer to Section  
3.10

## 3.17 PRIMARY PCB REPLACEMENT

**WARNING:** It is critical that the correct boiler size and fuel type is entered in to the boiler.

**CAUTION:** Fit the earth strap provided with the PCB to your wrist and secure to a suitable earth on the boiler chassis.

Refer to Section  
3.2

1. Remove and keep the screw.
2. Carefully release the four retaining clips and remove control box cover.
3. Unplug all lead connections to the PCB.
4. Spring out the four side retaining clips and pull the PCB upwards to clear the corner retaining posts.
5. Fit the new PCB and re-connect all plug connections.
6. Reassemble in reverse order.
7. Switch mains power on, wait for "uP" to be shown.
8. Simultaneously press Mode & Restart buttons so that "oF" is shown.
9. Switch mains power off and wait for 5s.
10. Switch mains power on, wait for "F9" to be shown.
11. Rotate the temperature knob until "F9SU" is shown. Restart.
12. Rotate the temperature knob until "F9n" is shown. Restart.
13. Rotate the temperature knob until the appropriate boiler output is shown (15 kW, 18 kW, 24 kW or 30 kW).
14. Press Restart.
15. The boiler type (SU), gas type (n), output (15/18/24/30) and parameter set number will be shown in rotation. If this is OK press Restart to complete the configuration, otherwise switch mains power off to start again.
16. Check that the boiler operates.

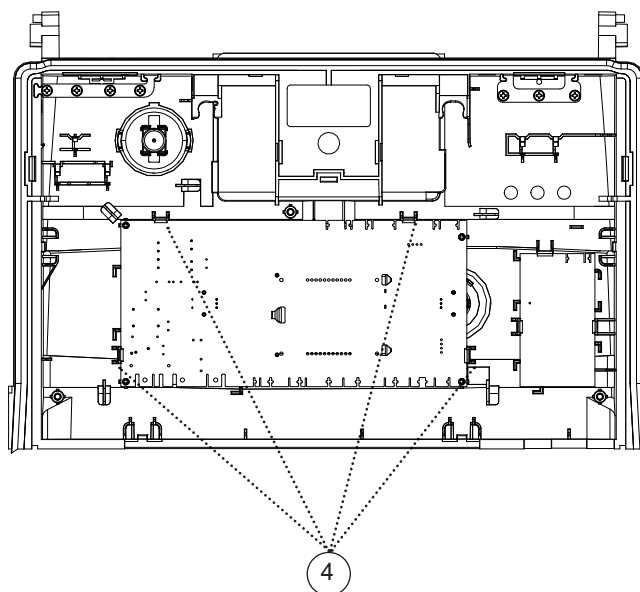
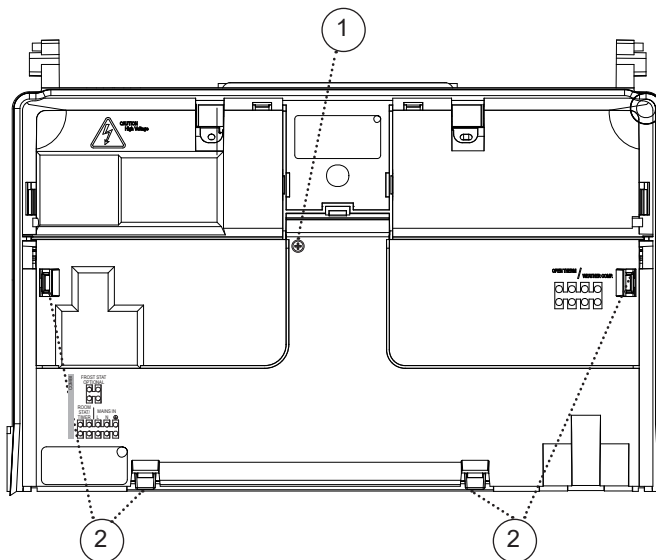

## 3.18 PRESSURE GAUGE REPLACEMENT

Refer to Section 3.2

1. Drain the system.

Refer to Section 3.3

2. Remove the boiler front (see section 3.4 **Boiler Front Panel Removal / Replacement** ), lower the control panel and remove the control box cover.
3. Ensuring there is no pressure in the system unclip the C clip from the flow pipe port and remove the capillary connection together with 'O' ring.

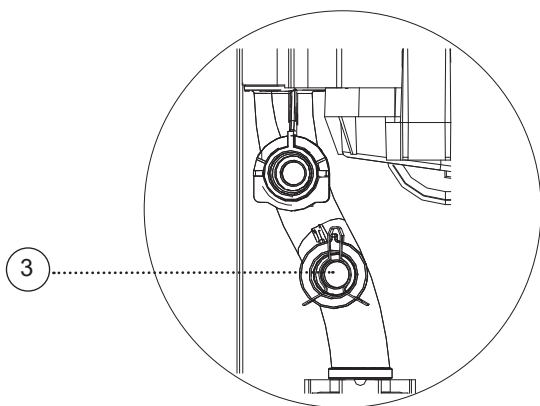

4. Releasing the two retaining clips on the pressure gauge ease the pressure gauge through the front of the control panel.
5. Fit the new pressure gauge from the front of the lower control panel ensuring correct orientation. Locate push fit connection into flow pipe ensuring 'O' ring in place and secure with the C clip.
6. Refill the boiler.

Refer to Section 2.17

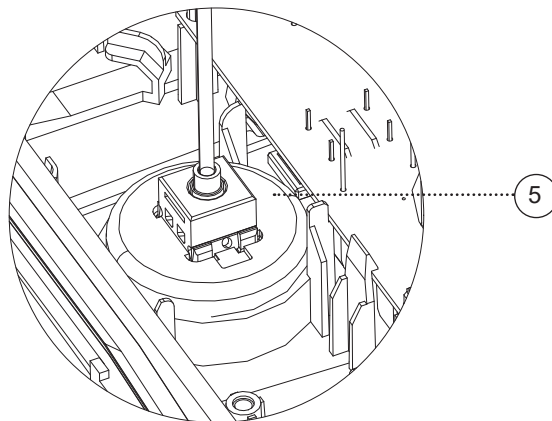

## 3.19 PRV REPLACEMENT

Refer to Section 3.2

1. Drain the boiler.

Refer to Section 3.3

2. Remove the trap and rubber pipe.
3. Pull out and remove the clip retaining the PRV.
4. Lift out the PRV/pipe assembly.
5. Remove the pipe and transfer to the new PRV.
6. Reassemble ensuring the retaining clip is correctly fitted.

7. Check the operation of the PRV by raising the water pressure until the valve lifts. This should occur within 0.3 bar of the preset lift pressure.
8. Check no escape of water occurs except at the discharge point
9. Release water from the system until the minimum system design pressure is reached; 1.0 bar if the system is to be pre-pressurised.

SCAN for video



Refer to Section 2.17

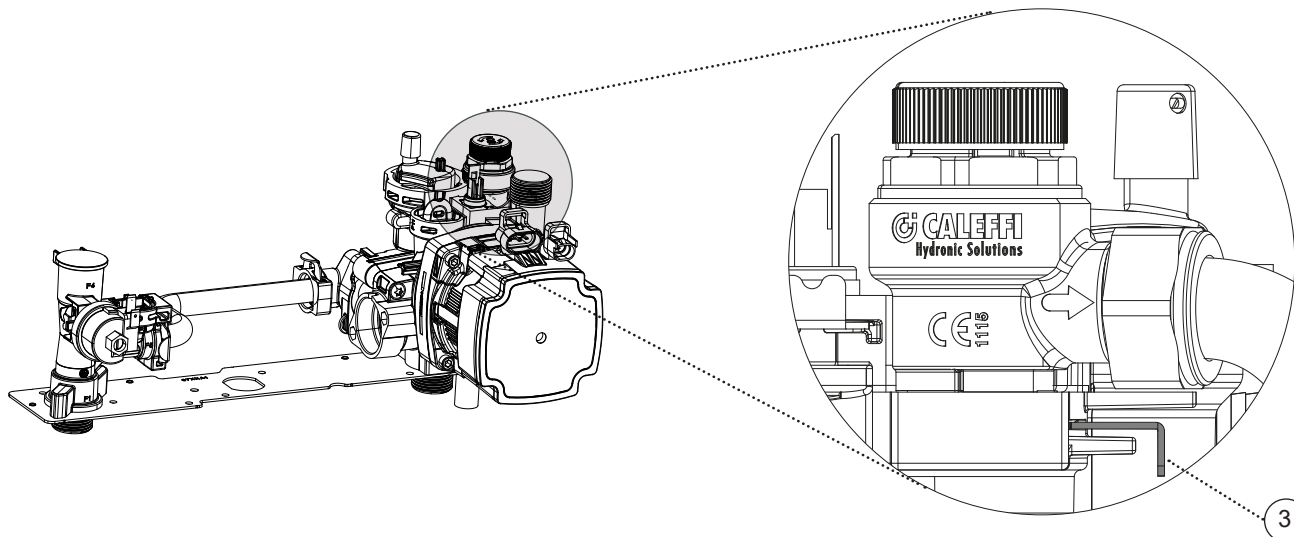

## 3.20 PUMP AUTOMATIC AIR VENT REPLACEMENT

Refer to Section  
3.2

1. Drain the boiler.

Refer to Section  
3.3

2. Remove the expansion vessel.

Refer to Section  
3.24

3. Firstly, increase access area by disconnecting the 22mm pipe connection at top of pump manifold and bottom of heat exchanger and remove pipe.
4. The automatic air vent head is retained in the pump body with a bayonet connection. The air vent head and float assembly is removed by turning the head anti-clockwise (viewed from above) and pulling upwards.

5. Reassemble. Ensure the air vent head 'O' ring seal is fitted.
6. Fully open the Pump Automatic Air Vent.
7. Refill the boiler. Check for leaks around the new air vent joint.

Refer to Section  
2.17

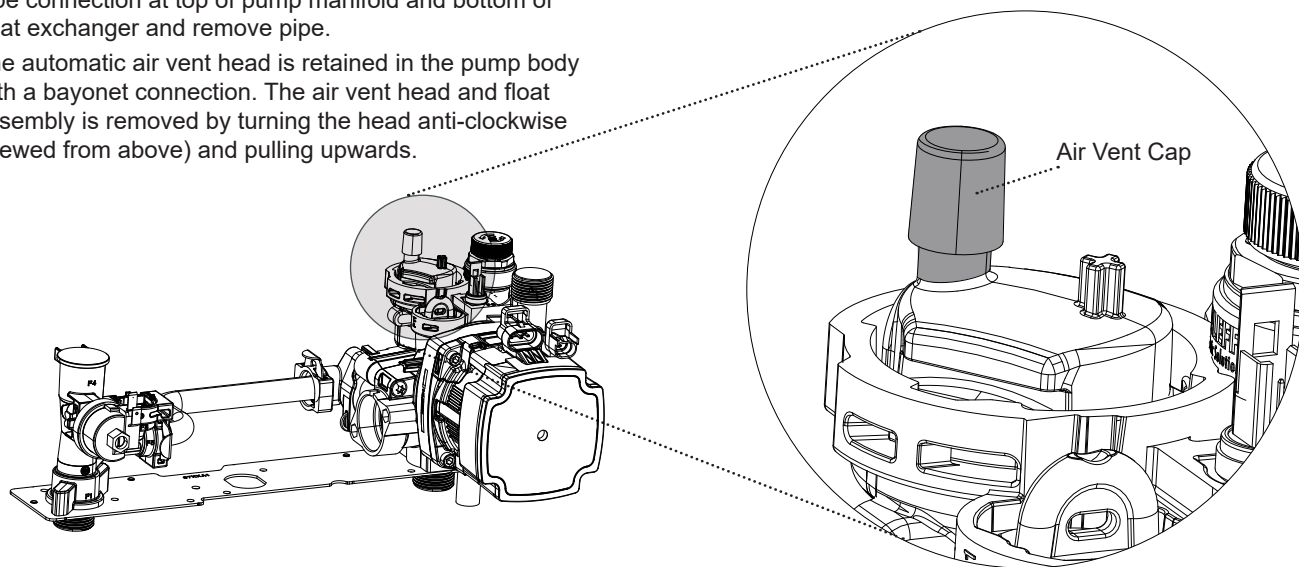

## 3.21 CH WATER PRESSURE SWITCH REPLACEMENT

Refer to Section  
3.2

1. Drain the boiler.

Refer to Section  
3.3

2. Pull off the two electrical connections.
3. Using a suitable tool, pull out the metal retaining clip.
4. Carefully withdraw the pressure switch.
5. Fit the new pressure switch and re-assemble. Ensuring that the 'O' ring is fitted, replace clip.
6. Refill the boiler.

Refer to Section  
2.17

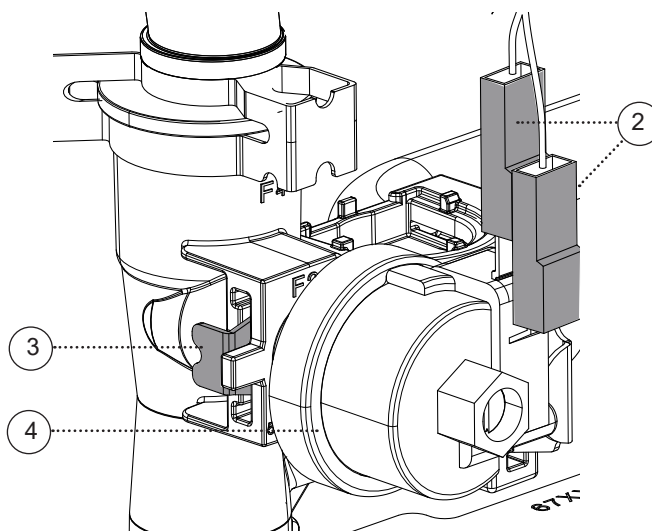

## 3.22 PUMP HEAD REPLACEMENT

Refer to Section  
3.2

1. Drain the boiler.

Refer to Section  
3.3

2. Disconnect the two electrical leads from the pump.
3. Remove the 4 allen screws retaining the pump head.
4. Remove the pump head.  
Be aware of water spillage.
5. Fit the new pump head.
6. Reassemble.
7. Refill the boiler.

Refer to Section  
2.17

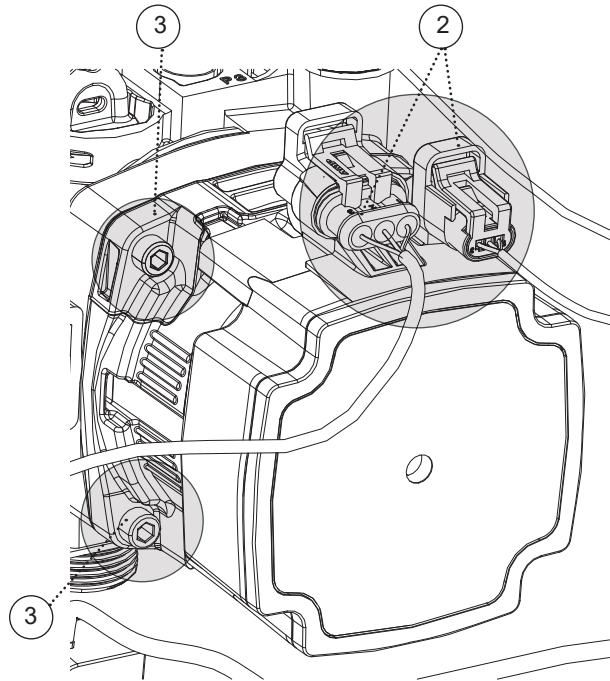

SERVICING

## 3.23 FLOW THERMISTOR REPLACEMENT

Refer to Section  
3.2

1. Drain down the boiler.

Refer to Section  
3.3

2. Unplug the electrical lead.
3. Unscrew the thermistor (to facilitate removal a 13 mm socket spanner should be used).
4. Fit the new thermistor using the sealing washer provided.

5. Reassemble in the reverse order.
6. Refill the boiler.

Refer to Section  
2.17

7. Check that the boiler operates.

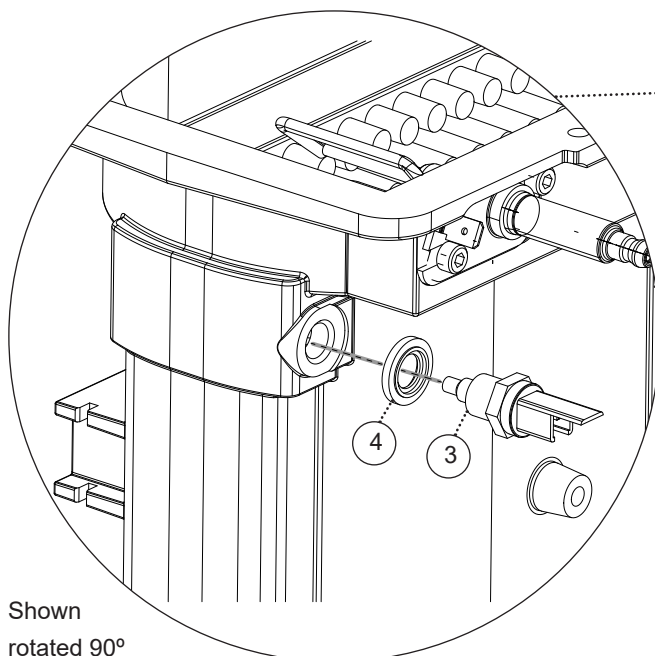

Shown  
rotated 90°

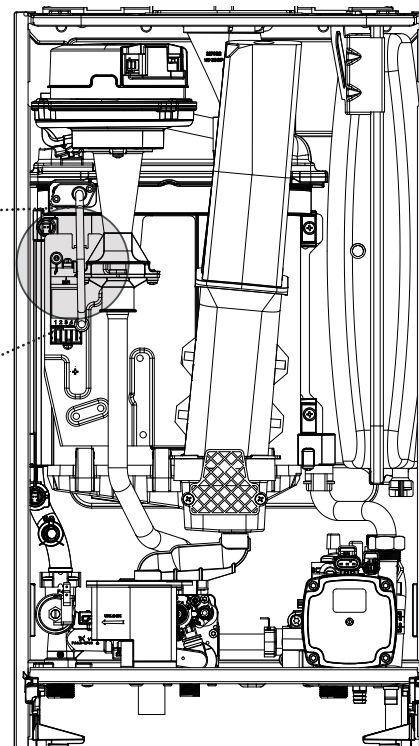

### 3.24 EXPANSION VESSEL RECHARGING & REPLACEMENT

Refer to Section  
3.4

#### RECHARGING

1. Remove the charge point cover.
2. Recharge the tank pressure to 0.75 bar.
3. Re-assemble in reverse order.
4. Check that the boiler operates.

#### REPLACEMENT

5. Drain the boiler CH circuit.

Refer to Section  
3.3

6. Remove the retaining clip on the vessel water connection pipe and remove the pipe.
7. Support the expansion vessel and unscrew the 2 screws from the securing bracket, located on the top of the boiler, and remove. (Note the position of the bracket on the vessel)
8. Remove the expansion vessel.
9. Fit the new expansion vessel.
10. Reassemble in reverse order ensuring the seal is in place.
11. Refill the boiler and check for leaks.

Refer to Section  
2.17

12. Check tht the boiler operates.

Recharge  
Point

1

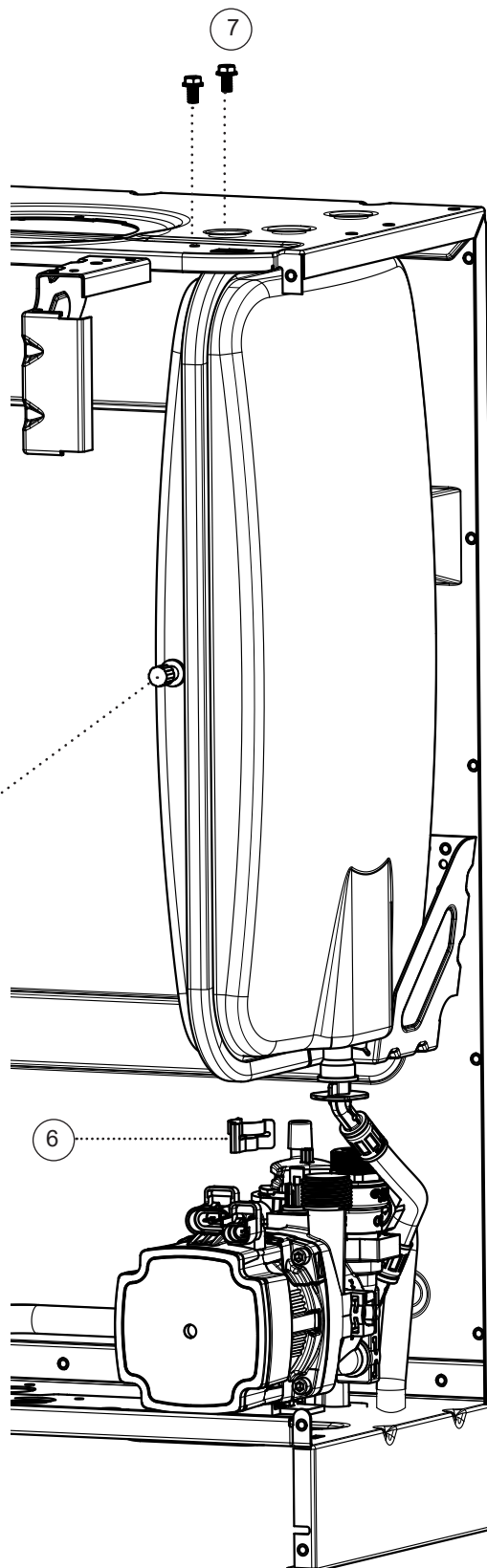

## 3.25 HEAT ENGINE REPLACEMENT

Refer to Section  
2.1

**CAUTION:** Protect the gas and electrical controls with a waterproof sheet.

Refer to Section  
3.2

1. Drain the boiler.

Refer to Section  
3.3

2. Undo the two screws and remove the sump cover retaining the lower flue manifold.

3. Lift the manifold to clear the bottom sealing gasket and remove manifold.

Refer to Section  
3.5

4. Remove the fan / venturi assembly and place on one side.

Refer to Section  
3.7

5. Remove the burner and place on one side.

Refer to Section  
3.6

6. Remove the heat exchanger flow thermistor.

Refer to Section  
3.23

7. Remove the spark generator and trap.

Refer to Section  
3.14 & 3.10

8. Remove the gas valve.

Refer to Section  
3.15

9. Remove the expansion vessel.

Refer to Section  
3.24

10. Remove the 2 M5 screws retaining the spark generator, mounting bracket and transfer bracket to the new heat exchanger.

11. Undo the pump union nut and remove pipe.

12. Remove the two retaining pipe clips and remove pipes.

13. Remove the condensate rubber pipe.

Refer to Section  
3.10 No.1

14. Remove the two heat exchanger fixing screws.

15. Remove the Heat exchanger, slide out of location bracket.

16. If replacement sump required: Rotate heat exchanger assembly 180°. Place new sump onto heat exchanger, ensuring correct orientation and seal is in place. Then gently apply pressure to the base of the sump at each tab fixing point and engage tabs onto the heat exchanger.

17. Reassemble, ensuring the heat exchanger is located correctly in the LHS retaining bracket. Replace any new 'O' rings supplied with new heat exchanger and replace gaskets or seals if any sign of damage is evident. When replacing the spring clips located on the return pipe connection, ensure clip is oriented to correctly match connecting pipe diameters.

18. Ensure the trap is filled with water.

Refer to Section  
3.10

19. Refill the boiler and check for leaks.

Refer to Section  
2.17

20. Ensure all gas valve connections are gas tight with a gas soundness check up to the gas control valve.

21. Check that the boiler operates.

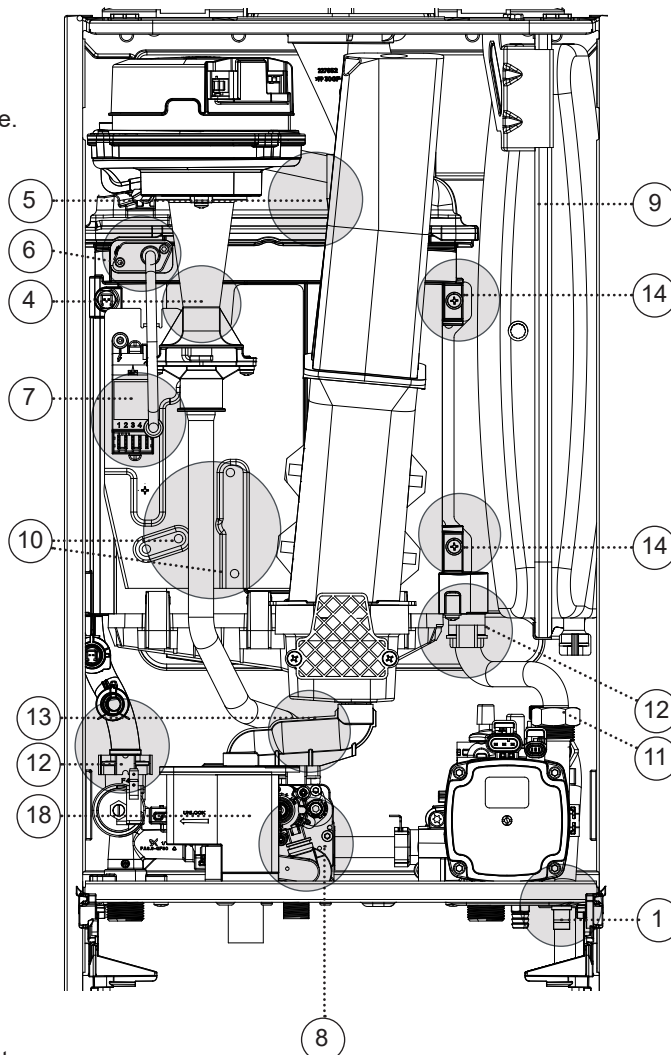

## 4.1 FAULT FINDING MAIN MENU

|                            |   |  |
|----------------------------|---|--|
| 'L 01'                     | → | Go to Section 4.2: Flow Temperature Overheat Lockout               |
| 'L 02'                     | → | Go to Section 4.3: Ignition Lockout                                |
| 'L 0C'                     | → | 5 Restarts within 15 minutes: Turnpower off & on                   |
| 'L 06'                     | → | Go to Section 4.4: False Flame Lockout                             |
| 'F 01'                     | → | Go to Section 4.5: Low Water Pressure                              |
| 'F 02'                     | → | Go to Section 4.6: Flame Loss                                      |
| 'F 03'                     | → | Go to Section 4.7: Fan Fault                                       |
| 'L 04' or 'F 04'           | → | Go to Section 4.8: Flow Thermistor Fault                           |
| 'L 05' or 'F 05'           | → | Go to Section 4.9: Return Thermistor Fault                         |
| 'L 0d'                     | → | Go to Section 4.3: Ignition Lockout: Blocked Flue/Condensate       |
| 'F 06'                     | → | Go to Section 4.10: Outside Sensor Fault                           |
| 'F 07'                     | → | Low Mains Voltage: Contact Electricity Provider                    |
| 'F 09'                     | → | PCB Fault: Replace PCB   |
| 'F 0U'                     | → | Go to Section 4.14: Flow/Return Differential greater than 50°C     |
| 'F 0t'                     | → | Room Thermostat Fault: Check Room Stat & connections               |
| 'F 10'                     | → | Spark Generator Fault: Check wiring, if OK replace spark generator |
| 'F 12'                     | → | Pump Rotor Blocked: Clear blockage                                 |
| 'F 13' or 'F 15' or 'F 17' | → | Pump Fault: Check pump wiring, if OK replace pump                  |
| 'F 14'                     | → | High Mains Voltage: Contact electricity provider                   |
| 'F 16'                     | → | Gas Valve Fault: Check gas valve wiring, if OK replace gas valve   |
| No CH, but HW OK           | → | Go to Section 4.11   |
| No Display                 | → | Go to Section 4.12   |
| No HW, but CH OK           | → | Go to Section 4.13   |

## 4.2 'L 01' - OVERHEAT LOCKOUT

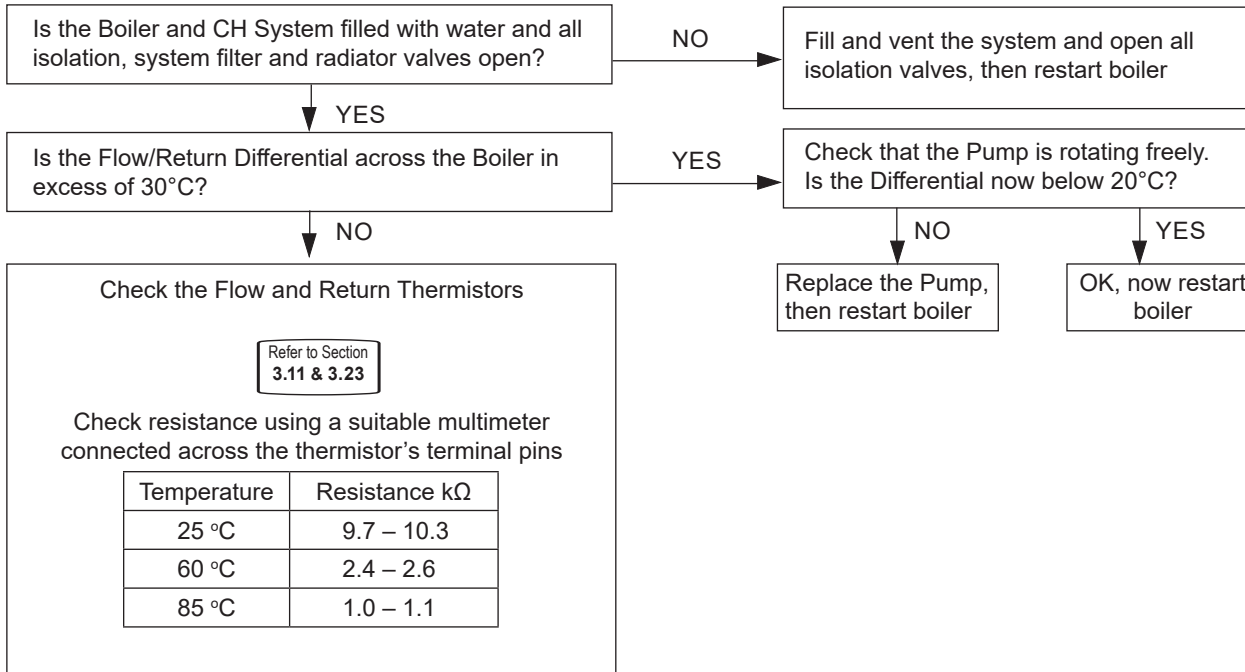

## 4.3 'L 02' - IGNITION LOCKOUT

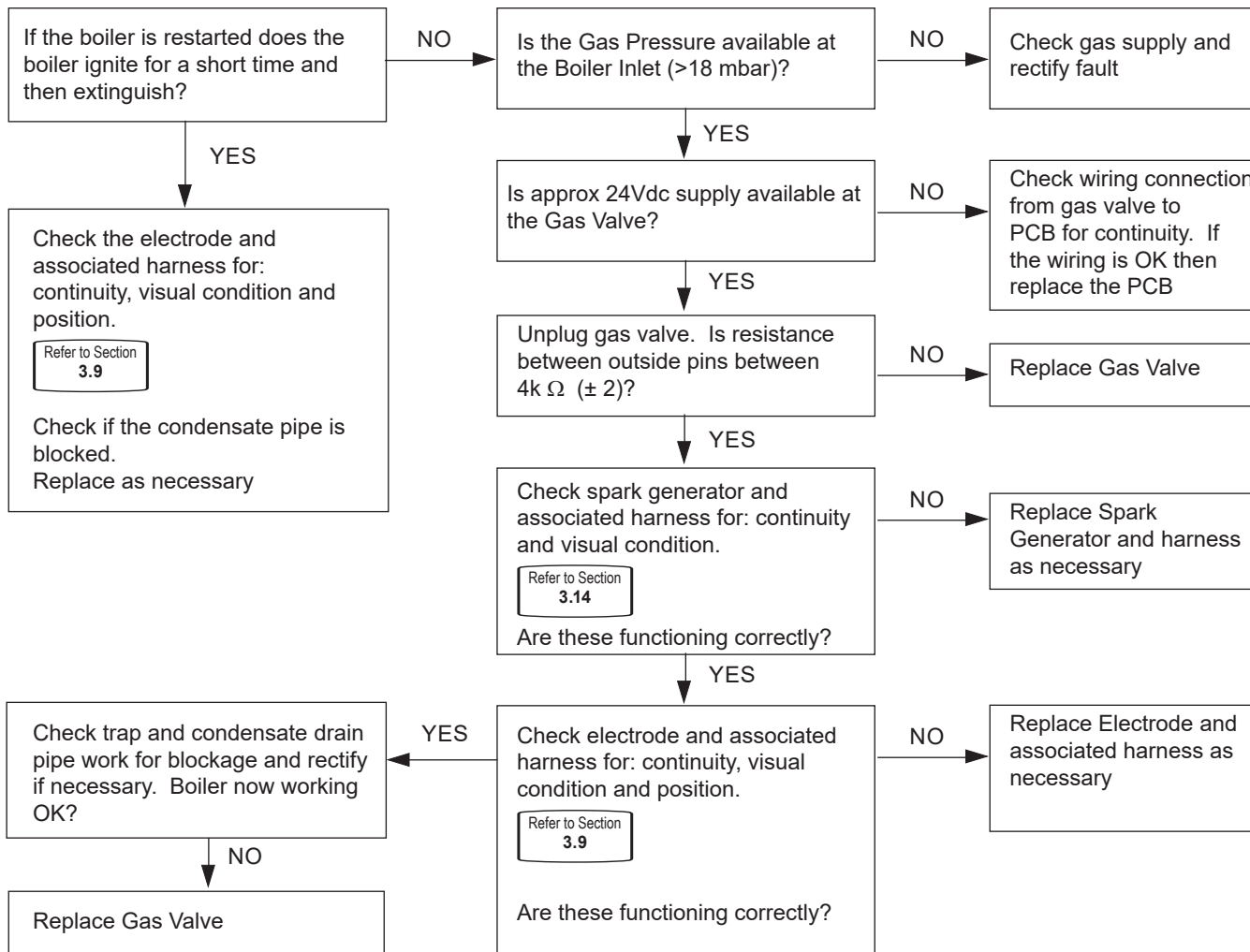

## Section 4 - Fault Finding

### 4.4 'L 06' - FLAME ON BEFORE GAS VALVE ON

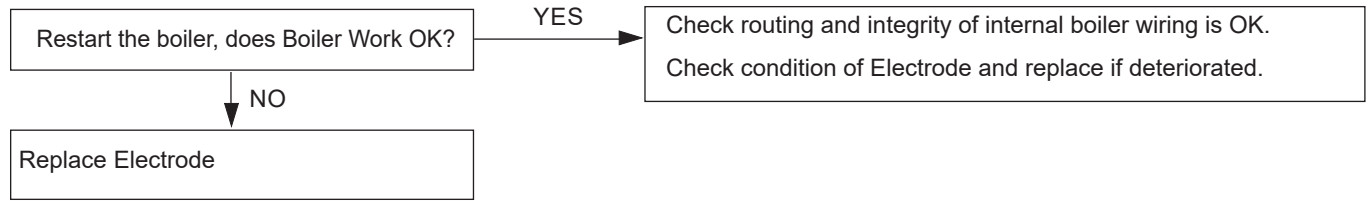

### 4.5 'F 01' - LOW WATER PRESSURE

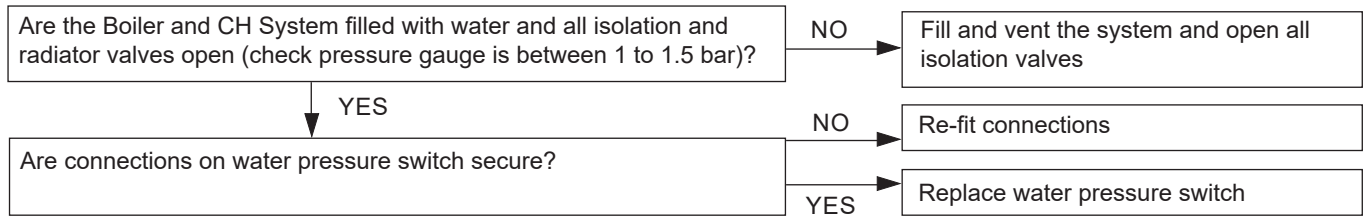

### 4.6 'F 02 OR FN OR LN' - FLAME LOSS

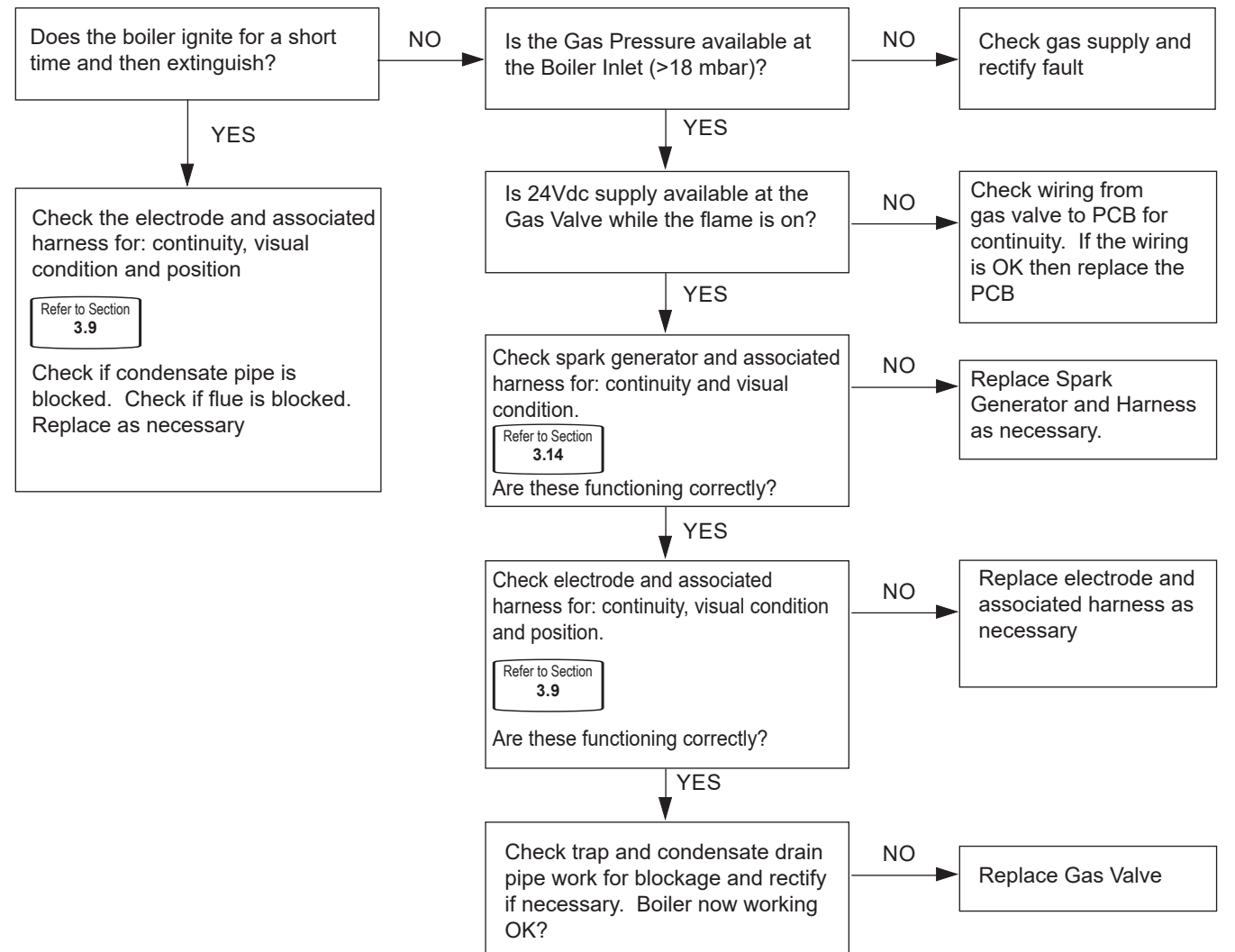

## 4.7 'F 03' - FAN FAULT

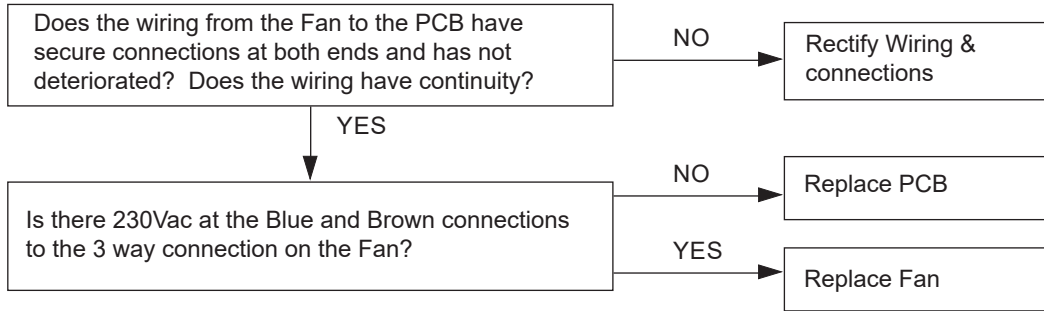

## 4.8 F 04 OR L 04' - FLOW THERMISTOR FAULT

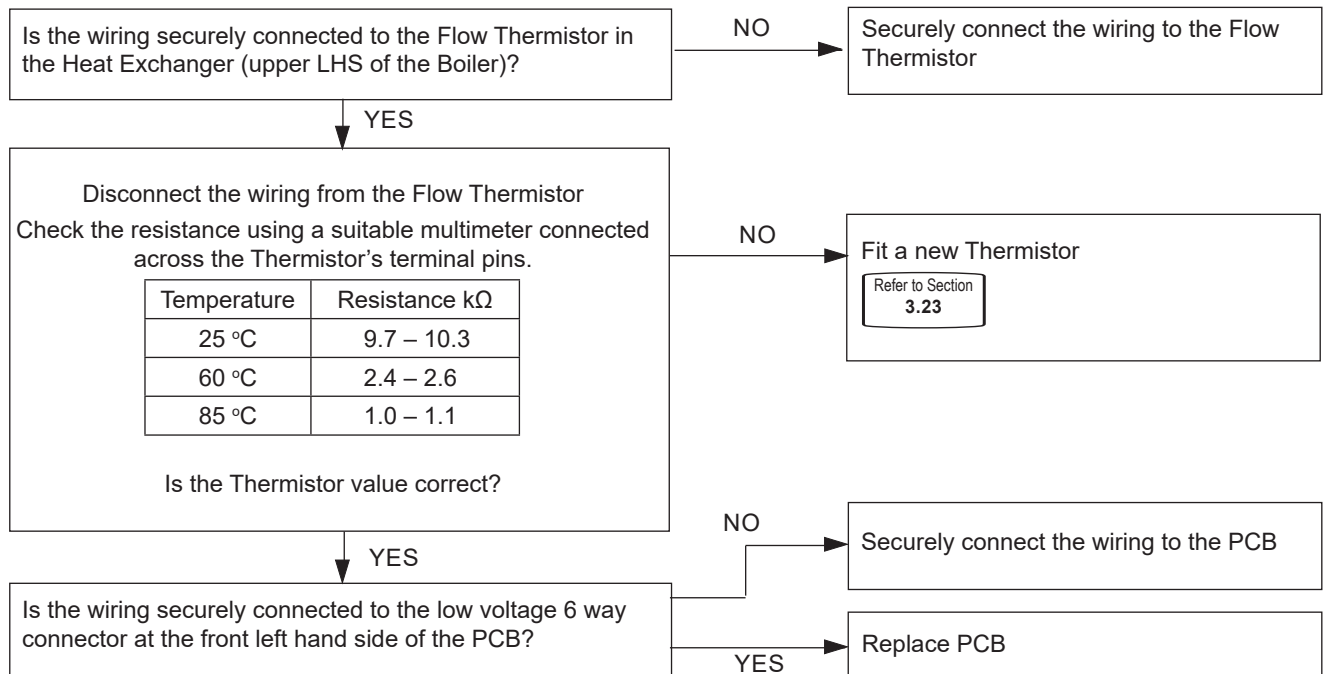

### 4.9 'F 05 OR L 05' - RETURN THERMISTOR FAULT

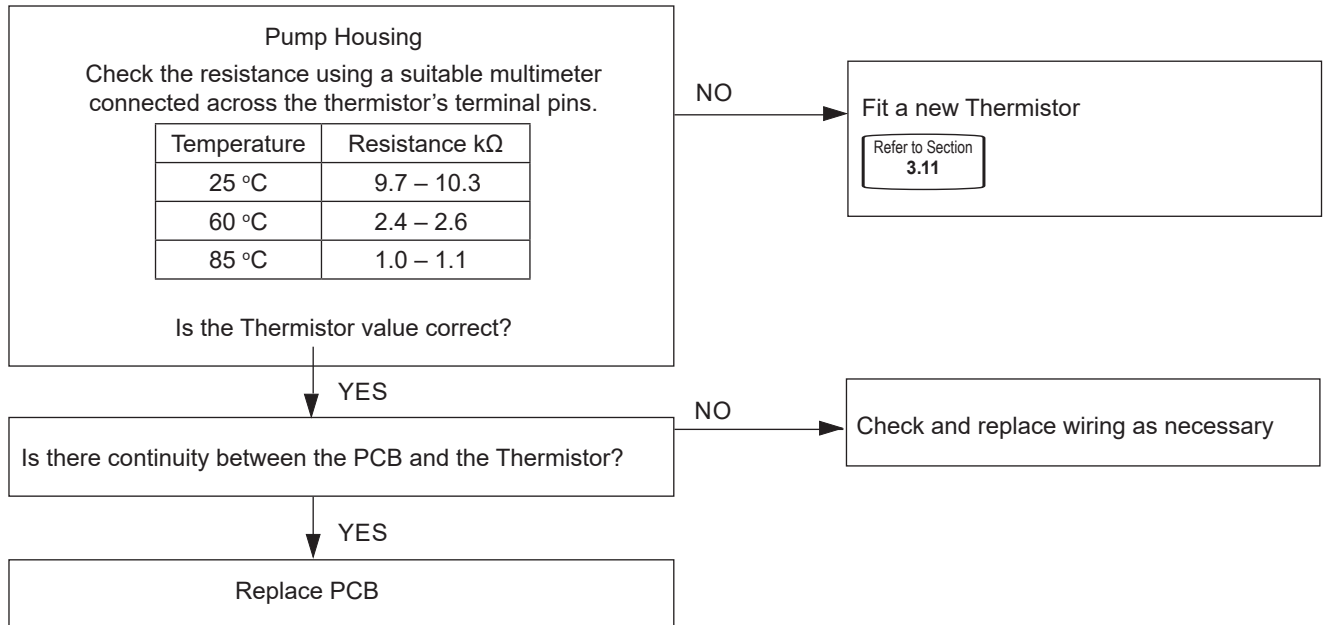

### 4.10 'F 06' - OUTSIDE SENSOR FAULT

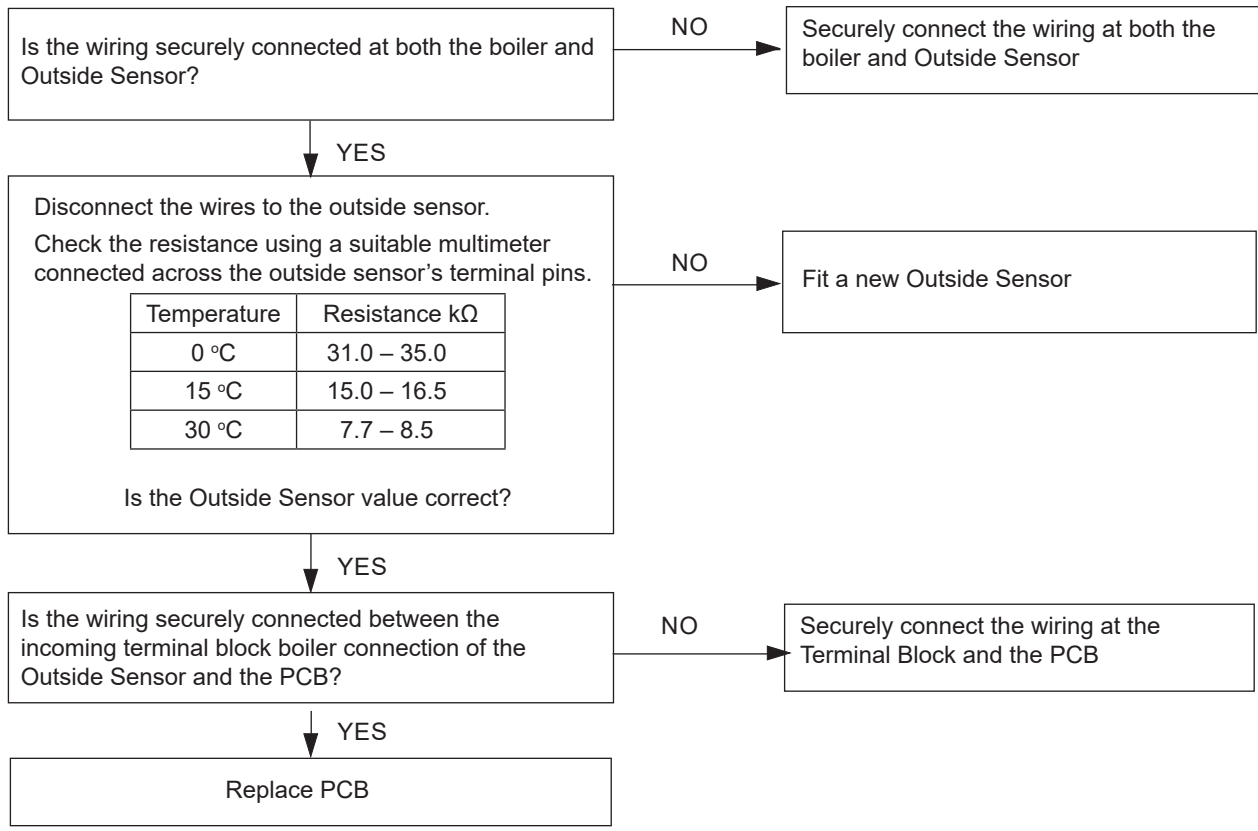

FAULT FINDING

### 4.11 NO CH OPERATION

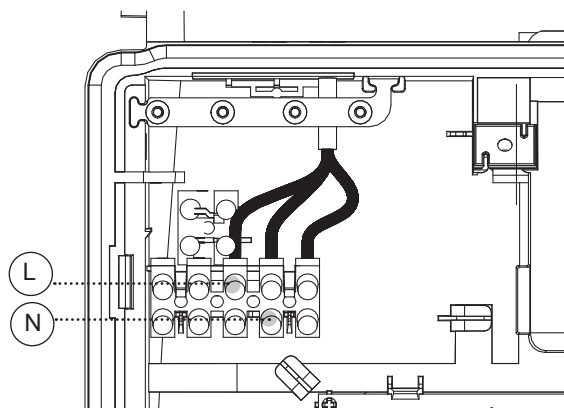
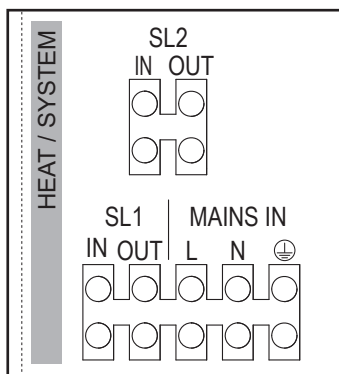
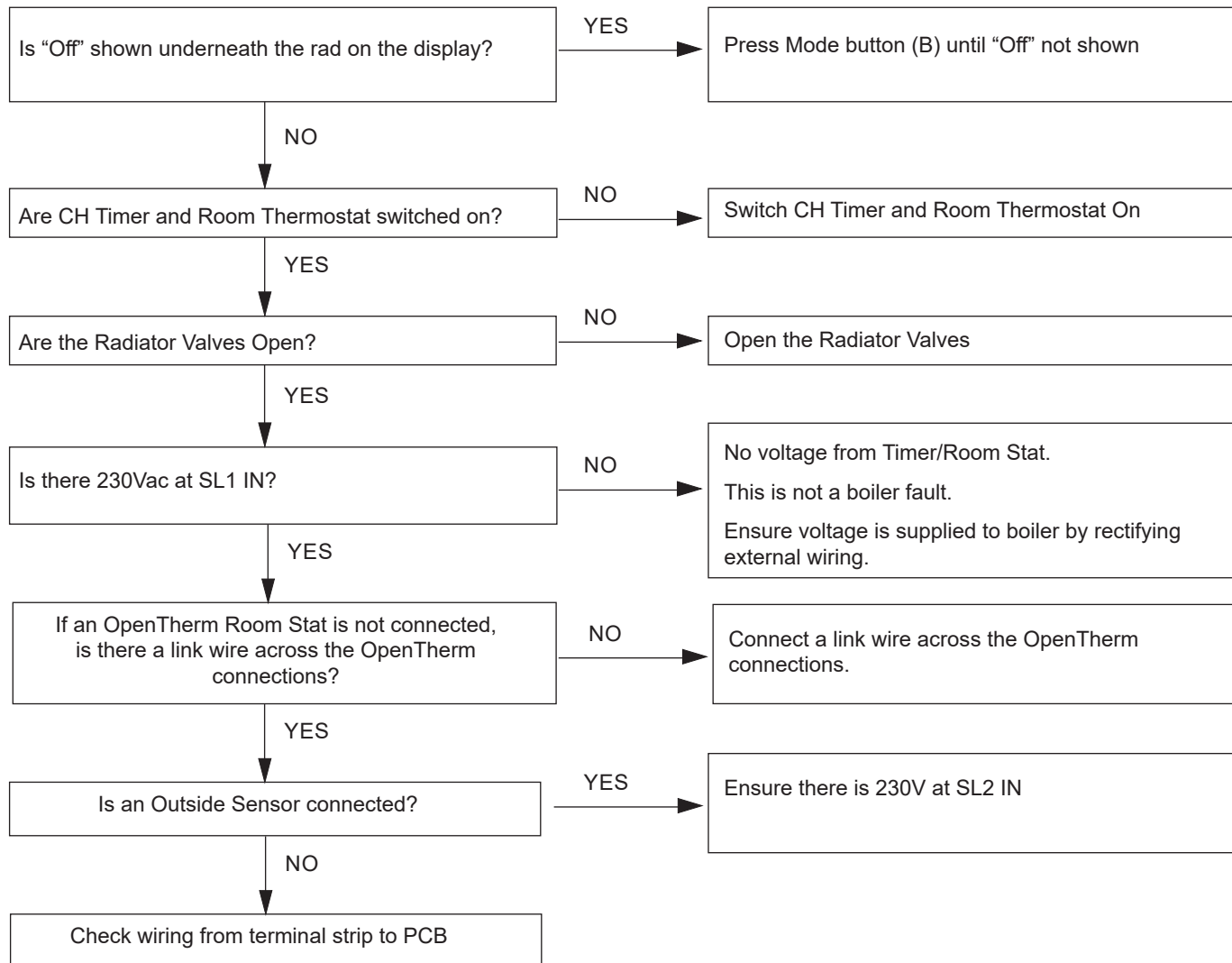

## 4.12 NO DISPLAY

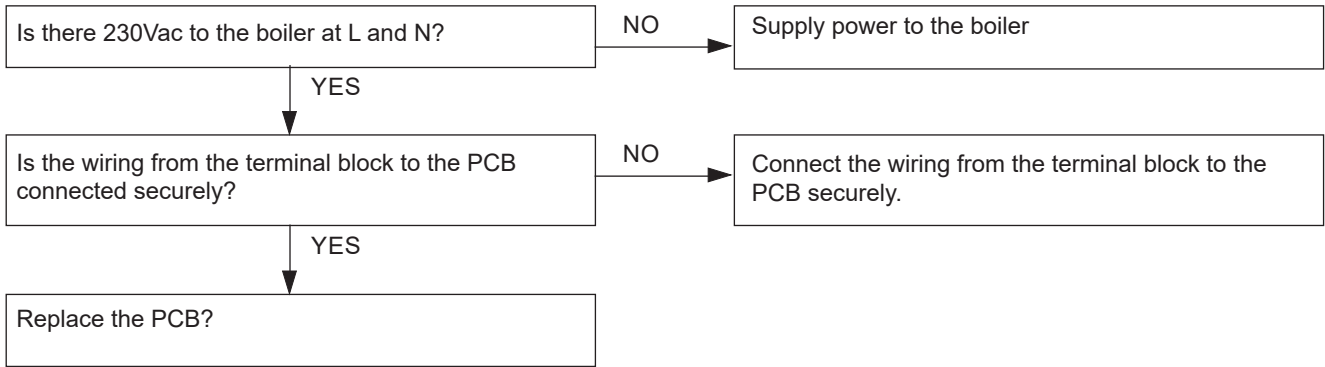

## 4.13 NO DHW OPERATION

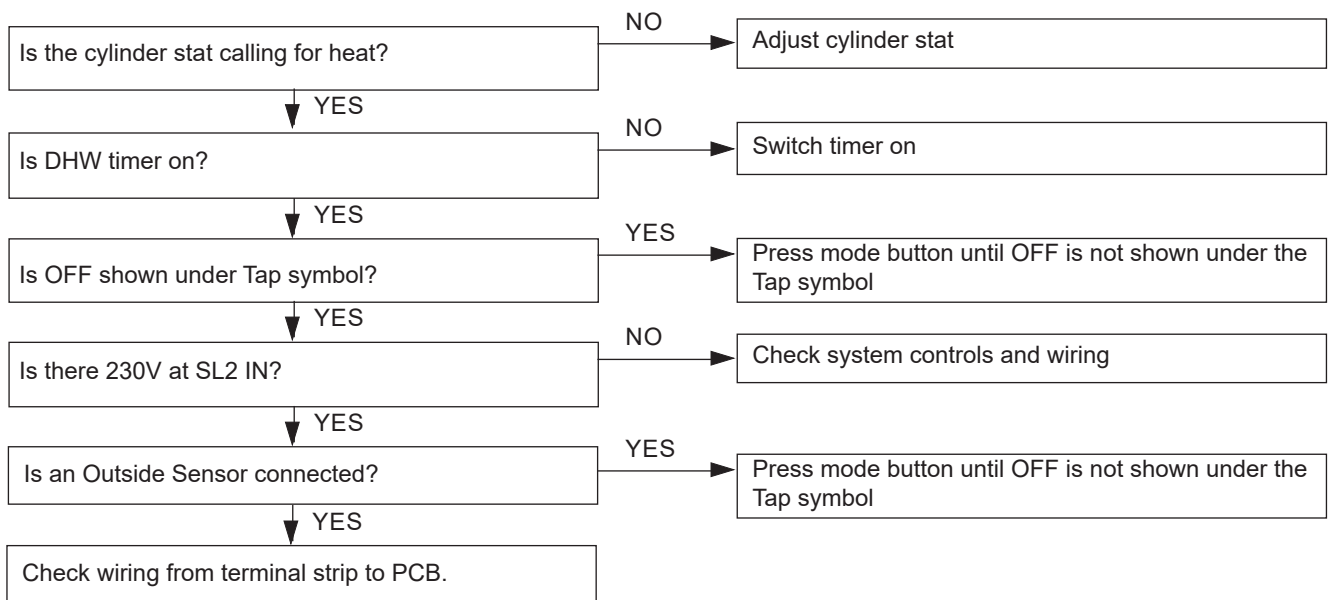

## 4.14 FLOW/RETURN DIFFERENTIAL GREATER THAN 50°C

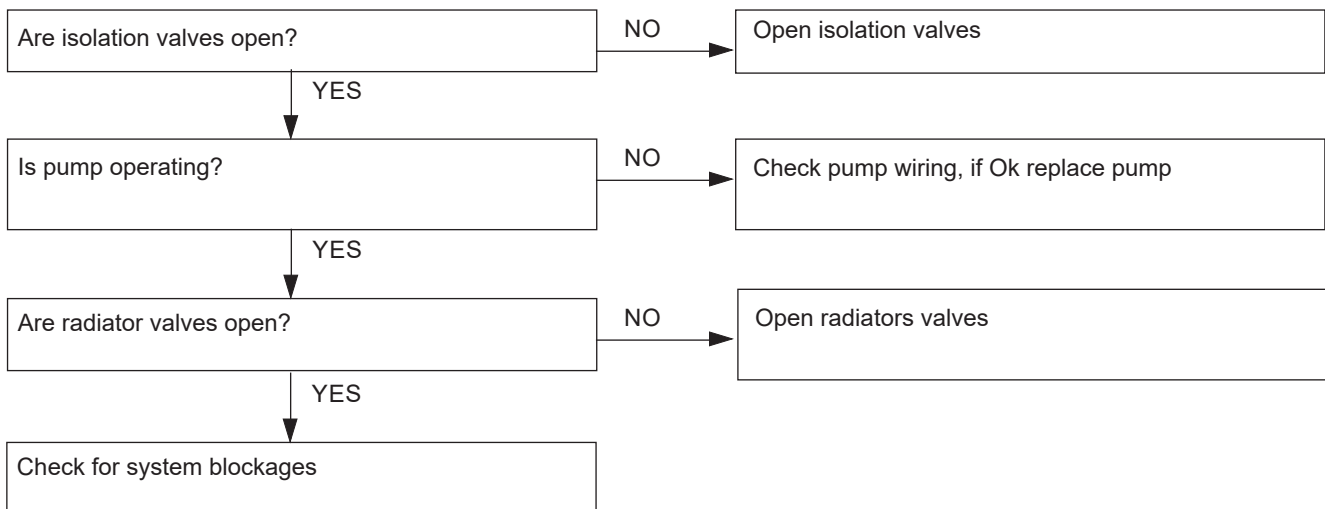

FAULT FINDING

## Section 5 - Spare Parts

When replacing any part on this appliance use only spare parts that you can be assured conform to the safety and performance specification that we require. Do not use reconditioned or copy parts that have not been clearly authorised by Ideal.

Failure to do so could affect safety or performance of this appliance.

Comprehensive spares parts information and details of approved Ideal Parts Distributors are available on **idealparts.com**

**LINK**  
to spares



**Our Parts team are also available to help with your Ideal Spare Parts enquiries on 01482 498665.**

When calling, and to ensure we can provide you with the most accurate parts information, please ensure you have the following to hand;

- Boiler Model
- Appliance GC Number
- Boiler Serial Number

# Code Of Practice

For the installation, commissioning and servicing of domestic heating and hot water products

Benchmark places responsibilities on both manufacturers and installers.\* The purpose is to ensure that customers\*\* are provided with the correct equipment for their needs, that it is installed, commissioned and serviced in accordance with the manufacturer's instructions by competent persons and that it meets the requirements of the appropriate Building Regulations. Installers are required to carry out work in accordance with the following:

### Standards of Work

- Be competent and qualified to undertake the work required.
- Install, commission, service and use products in accordance with the manufacturer's instructions provided.
- Ensure that where there is responsibility for design work, the installation is correctly sized and fit for purpose.
- Meet the requirements of the appropriate Building Regulations. Where this involves notifiable work be a member of a Competent Persons Scheme or confirm that the customer has notified Local Authority Building Control (LABC), prior to work commencing.
- Complete all relevant sections of the Benchmark Checklist/Service Record when carrying out commissioning or servicing of a product or system.
- Ensure that the product or system is left in a safe condition and, whenever possible, in good working order.
- Highlight to the customer any remedial or improvement work identified during the course of commissioning or servicing work.
- Refer to the manufacturer's helpline where assistance is needed.
- Report product faults and concerns to the manufacturer in a timely manner.

### Customer Service

- Show the customer any identity card that is relevant to the work being carried out prior to commencement or on request.
- Give a full and clear explanation/demonstration of the product or system and its operation to the customer.
- Hand over the manufacturer's instructions, including the Benchmark Checklist, to the customer on completion of an installation.
- Obtain the customer's signature, on the Benchmark Checklist, to confirm satisfactory demonstration and receipt of manufacturer's instructions.
- Advise the customer that regular product servicing is needed, in line with manufacturers' recommendations, to ensure that safety and efficiency is maintained.
- Respond promptly to calls from a customer following completion of work, providing advice and assistance by phone and, if necessary, visiting the customer.
- Rectify any installation problems at no cost to the customer during the installer's guarantee period.



\*The use of the word "installer" is not limited to installation itself and covers those carrying out installation, commissioning and/or servicing of heating and hot water products, or the use of supporting products (such as water treatment or test equipment).

\*\*Customer includes householders, landlords and tenants.

# Benchmark Commissioning & Warranty Validation Service Record

It is a requirement that the boiler is installed and commissioned to the manufacturers' instructions and the data fields on the commissioning checklist completed in full.

To instigate the boiler warranty the boiler needs to be registered with the manufacturer within one month of the installation. The warranty rests with the end-user (consumer), and they should be made aware it is ultimately their responsibility to register with the manufacturer, within the allotted time period.

It is essential that the boiler is serviced in line with the manufacturers' recommendations, at least annually. This must be carried out by a competent Gas Safe registered engineer. The service details should be recorded on the Benchmark Service and Interim Boiler Work Record and left with the householder. Failure to comply with the manufacturers' servicing instructions and requirements will invalidate the warranty.



[www.hhic.co.uk](http://www.hhic.co.uk)

**This Commissioning Checklist is to be completed in full by the competent person who commissioned the boiler as a means of demonstrating compliance with the appropriate Building Regulations and then handed to the customer to keep for future reference.**

Failure to install and commission according to the manufacturers' instructions and complete this Benchmark Commissioning Checklist will invalidate the warranty. This does not affect the customer's statutory rights.

\* All installations in England and Wales must be notified to Local Authority Building Control (LABC) either directly or through a Competent Persons Scheme. A Building Regulations Compliance Certificate will then be issued to the customer.

© Heating and Hotwater Industry Council (HHIC)



[www.centralheating.co.uk](http://www.centralheating.co.uk)

# Section 6 - Benchmark to Commissioning

## GAS BOILER SYSTEM COMMISSIONING CHECKLIST & WARRANTY VALIDATION RECORD

|   |  |                              |  |        |  |                               |  |                    |  |                     |     |                     |  |
|---|--|------------------------------|--|--------|--|-------------------------------|--|--------------------|--|---------------------|-----|---------------------|--|
| Address:  |  |                              |  |        |  |                               |  |                    |  |                     |     |                     |  |
| Boiler make and model:  |  |                              |  |        |  |                               |  |                    |  |                     |     |                     |  |
| Boiler serial number:   |  |                              |  |        |  |                               |  |                    |  |                     |     |                     |  |
| Commissioned by (PRINT NAME):   |  |                              |  |        |  | Gas Safe registration number: |  |                    |  |                     |     |                     |  |
| Company name:   |  |                              |  |        |  | Telephone number:             |  |                    |  |                     |     |                     |  |
| Company email:  |  |                              |  |        |  | Company address:              |  |                    |  |                     |     |                     |  |
|   |  |                              |  |        |  |                               |  |                    |  | Commissioning date: |     |                     |  |
| Heating and hot water system complies with the appropriate Building Regulations?  |  |                              |  |        |  |                               |  |                    |  |                     | Yes |                     |  |
| Optional: Building Regulations Notification Number (if applicable):   |  |                              |  |        |  |                               |  |                    |  |                     |     |                     |  |
| Time, temperature control and boiler interlock provided for central heating and hot water   |  |                              |  |        |  |                               |  |                    |  |                     | Yes |                     |  |
| Boiler Plus requirements (tick the appropriate box(s))  |  |                              |  |        |  |                               |  |                    |  |                     |     |                     |  |
| Boiler Plus option chosen for combination boiler in ENGLAND   |  |                              |  |        |  | Weather compensation          |  |                    | Smart thermostat with automisation and optimisation    |                     |     |                     |  |
|   |  |                              |  |        |  | Load compensation             |  |                    | Flue Gas Heat Recovery                                 |                     |     |                     |  |
| Time and temperature control to hot water   |  |                              | Cylinder thermostat and programmer/timer |        |  |                               |  |                    | Combination boiler                                     |                     |     |                     |  |
| Zone valves   |  |                              | pre-existing                             |        |  | Fitted                        |  |                    | Not required   |                     |     |                     |  |
| Thermostatic radiator valves  |  |                              | pre-existing                             |        |  | Fitted                        |  |                    | Not required   |                     |     |                     |  |
| Automatic bypass to system  |  |                              | pre-existing                             |        |  | Fitted                        |  |                    | Not required   |                     |     |                     |  |
| Underfloor heating  |  |                              | pre-existing                             |        |  | Fitted                        |  |                    | Not required   |                     |     |                     |  |
| Water quality   |  |                              |  |        |  |                               |  |                    |  |                     |     |                     |  |
| The system has been flushed, cleaned and a suitable inhibitor applied upon final fill, in accordance with BS7593 and boiler manufacturers' instructions |  |                              |  |        |  |                               |  |                    |  |                     | Yes |                     |  |
| What system cleaner was used?   |  |                              |  |        |  | Brand:                        |  |                    | Product:   |                     |     |                     |  |
| What inhibitor was used?  |  |                              |  |        |  | Brand:                        |  |                    | Product:   |                     |     |                     |  |
| Primary water system filter   |  |                              | pre-existing                             |        |  | Fitted                        |  |                    | Not required   |                     |     |                     |  |
| CENTRAL HEATING MODE measure and record (as appropriate)  |  |                              |  |        |  |                               |  |                    |  |                     |     |                     |  |
| Gas rate (for combination boilers complete DHW mode gas rate)   |  |                              |  |        |  | m <sup>3</sup> /hr            |  |                    | or   |                     |     | ft <sup>3</sup> /hr |  |
| Central heating output left at factory settings?  |  |                              |  |        |  | Yes                           |  |                    | No   |                     |     |                     |  |
| If no, what is the maximum central heating output selected?   |  |                              |  |        |  |                               |  |                    |  |                     |     | kW                  |  |
| Dynamic gas inlet pressure  |  |                              |  |        |  |                               |  |                    |  |                     |     | mbar                |  |
| Central heating flow temperature  |  |                              |  |        |  |                               |  |                    |  |                     |     | °C                  |  |
| Central heating return temperature  |  |                              |  |        |  |                               |  |                    |  |                     |     | °C                  |  |
| System correctly balanced/rebalanced?   |  |                              |  |        |  | Yes                           |  |                    |  |                     |     |                     |  |
| COMBINATION BOILERS ONLY  |  |                              |  |        |  |                               |  |                    |  |                     |     |                     |  |
| Is the installation in a hard water area (above 200ppm)?  |  |                              |  |        |  | Yes                           |  |                    | No   |                     |     |                     |  |
| Water scale reducer/softener  |  |                              | pre-existing                             |        |  | Fitted                        |  |                    | Not required   |                     |     |                     |  |
| What type of scale reducer/softener has been fitted?  |  |                              |  |        |  | Brand:                        |  |                    | Product:   |                     |     |                     |  |
| Water meter fitted?   |  |                              |  |        |  | Yes                           |  |                    | No   |                     |     |                     |  |
| If yes- DHW expansion vessel  |  |                              | pre-existing                             |        |  | Fitted                        |  |                    | Not required   |                     |     |                     |  |
| Pressure reducing valve   |  |                              | pre-existing                             |        |  | Fitted                        |  |                    | Not required   |                     |     |                     |  |
| DOMESTIC HOT WATER MODE Measure and record  |  |                              |  |        |  |                               |  |                    |  |                     |     |                     |  |
| Gas rate  |  |                              |  |        |  | m <sup>3</sup> /hr            |  |                    | or   |                     |     | ft <sup>3</sup> /hr |  |
| Dynamic gas inlet pressure at maximum rate  |  |                              |  |        |  |                               |  |                    |  |                     |     | mbar                |  |
| Cold water inlet temperature  |  |                              |  |        |  |                               |  |                    |  |                     |     | °C                  |  |
| Hot water has been checked at all outlets   |  |                              |  |        |  | Yes                           |  |                    | Temperature  |                     |     | °C                  |  |
| CONDENSATE DISPOSAL   |  |                              |  |        |  |                               |  |                    |  |                     |     |                     |  |
| The condensate drain has been installed in accordance with the manufacturers' instructions and/or BS5546/BS6798   |  |                              |  |        |  |                               |  |                    |  |                     | Yes |                     |  |
| Point of termination  |  |                              |  |        |  | Internal                      |  |                    | External (only where internal termination impractical) |                     |     |                     |  |
| Method of disposal  |  |                              |  |        |  | Gravity                       |  |                    | Pumped   |                     |     |                     |  |
| ALL INSTALLATIONS   |  |                              |  |        |  |                               |  |                    |  |                     |     |                     |  |
| Record the following  |  | At max rate:                 |  | CO ppm |  | CO <sub>2</sub> %             |  | CO/CO <sub>2</sub> |  | Ratio               |     |                     |  |
|   |  | At min rate (where possible) |  | CO ppm |  | CO <sub>2</sub> %             |  | CO/CO <sub>2</sub> |  | Ratio               |     |                     |  |
| Where possible, has a flue integrity check been undertaken in accordance with manufacturers' instructions, and readings are correct?                    |  |                              |  |        |  |                               |  |                    |  |                     | Yes |                     |  |
| The operation of the boiler and system controls have been demonstrated to and understood by the customer  |  |                              |  |        |  |                               |  |                    |  |                     | Yes |                     |  |
| The manufacturers' literature, including Benchmark Checklist and Service Record, has been explained and left with the customer                          |  |                              |  |        |  |                               |  |                    |  |                     | Yes |                     |  |
| Commissioning Engineer's signature  |  |                              |  |        |  |                               |  |                    |  |                     |     |                     |  |
| Customer's signature<br>(To confirm satisfactory demonstration and receipt of manufacturers' literature)  |  |                              |  |        |  |                               |  |                    |  |                     |     |                     |  |

\* All installations in England and Wales must be notified to Local Authority Building Control (LABC) either directly or through a Competent Persons Scheme. A Building Regulations Compliance Certificate will then be issued to the customer.

© Heating and Hotwater Industry Council (HHIC)



www.centralheating.co.uk

# Section 6 - Benchmark to Commissioning

## SERVICE & INTERIM BOILER WORK RECORD

It is recommended that your boiler and heating system are regularly serviced and maintained, in line with manufacturers' instructions, and that the appropriate service / interim work record is completed.

### Service provider

When completing a service record (as below), please ensure you have carried out the service as described in the manufacturers' instructions. Always use the manufacturers' specified spare parts.

| SERVICE/INTERIM WORK ON BOILER <small>delete as appropriate</small>  |                   |                           |                    |     | Date:              |
|--|-------------------|---------------------------|--------------------|-----|--------------------|
| Engineer name:   |                   | Company name:             |                    |     |                    |
| Telephone N°:  |                   | Gas Safe registration N°: |                    |     |                    |
| Max rate   | CO                | ppm                       | CO <sub>2</sub>    | %   | CO/CO <sub>2</sub> |
| Min rate   | CO                | ppm                       | CO <sub>2</sub>    | %   | CO/CO <sub>2</sub> |
| Where possible, has a flue integrity check been undertaken in accordance with manufacturers' instructions, and readings are correct?*              |                   |                           |                    | yes |                    |
| Gas rate:  | m <sup>3</sup> /h | OR                        | ft <sup>3</sup> /h |     |                    |
| Were parts fitted? <small>delete as appropriate</small>  | Yes               | No                        |                    |     |                    |
| Parts fitted:  |                   |                           |                    |     |                    |
| System inhibitor concentration has been checked and appropriate action taken, in accordance with BS 7593 and boiler manufacturers' instructions. * |                   |                           |                    | yes | n/a                |
| Comments:  |                   |                           |                    |     |                    |
| Signature:   |                   |                           |                    |     |                    |

\*A System inhibitor efficacy test is required on every annual service in accordance with the manufacturers' instructions and BS 7593. It is only acceptable to not have undertaken this if the service engineers attendance visit was in between annual services to attend a non-water facing component.

| SERVICE/INTERIM WORK ON BOILER <small>delete as appropriate</small>  |                   |                           |                    |     | Date:              |
|--|-------------------|---------------------------|--------------------|-----|--------------------|
| Engineer name:   |                   | Company name:             |                    |     |                    |
| Telephone N°:  |                   | Gas Safe registration N°: |                    |     |                    |
| Max rate   | CO                | ppm                       | CO <sub>2</sub>    | %   | CO/CO <sub>2</sub> |
| Min rate   | CO                | ppm                       | CO <sub>2</sub>    | %   | CO/CO <sub>2</sub> |
| Where possible, has a flue integrity check been undertaken in accordance with manufacturers' instructions, and readings are correct?*              |                   |                           |                    | yes |                    |
| Gas rate:  | m <sup>3</sup> /h | OR                        | ft <sup>3</sup> /h |     |                    |
| Were parts fitted? <small>delete as appropriate</small>  | Yes               | No                        |                    |     |                    |
| Parts fitted:  |                   |                           |                    |     |                    |
| System inhibitor concentration has been checked and appropriate action taken, in accordance with BS 7593 and boiler manufacturers' instructions. * |                   |                           |                    | yes | n/a                |
| Comments:  |                   |                           |                    |     |                    |
| Signature:   |                   |                           |                    |     |                    |

\*A System inhibitor efficacy test is required on every annual service in accordance with the manufacturers' instructions and BS 7593. It is only acceptable to not have undertaken this if the service engineers attendance visit was in between annual services to attend a non-water facing component.

| SERVICE/INTERIM WORK ON BOILER <small>delete as appropriate</small>  |                   |                           |                    |     | Date:              |
|--|-------------------|---------------------------|--------------------|-----|--------------------|
| Engineer name:   |                   | Company name:             |                    |     |                    |
| Telephone N°:  |                   | Gas Safe registration N°: |                    |     |                    |
| Max rate   | CO                | ppm                       | CO <sub>2</sub>    | %   | CO/CO <sub>2</sub> |
| Min rate   | CO                | ppm                       | CO <sub>2</sub>    | %   | CO/CO <sub>2</sub> |
| Where possible, has a flue integrity check been undertaken in accordance with manufacturers' instructions, and readings are correct?*              |                   |                           |                    | yes |                    |
| Gas rate:  | m <sup>3</sup> /h | OR                        | ft <sup>3</sup> /h |     |                    |
| Were parts fitted? <small>delete as appropriate</small>  | Yes               | No                        |                    |     |                    |
| Parts fitted:  |                   |                           |                    |     |                    |
| System inhibitor concentration has been checked and appropriate action taken, in accordance with BS 7593 and boiler manufacturers' instructions. * |                   |                           |                    | yes | n/a                |
| Comments:  |                   |                           |                    |     |                    |
| Signature:   |                   |                           |                    |     |                    |

\*A System inhibitor efficacy test is required on every annual service in accordance with the manufacturers' instructions and BS 7593. It is only acceptable to not have undertaken this if the service engineers attendance visit was in between annual services to attend a non-water facing component.

| SERVICE/INTERIM WORK ON BOILER <small>delete as appropriate</small>  |                   |                           |                    |     | Date:              |
|--|-------------------|---------------------------|--------------------|-----|--------------------|
| Engineer name:   |                   | Company name:             |                    |     |                    |
| Telephone N°:  |                   | Gas Safe registration N°: |                    |     |                    |
| Max rate   | CO                | ppm                       | CO <sub>2</sub>    | %   | CO/CO <sub>2</sub> |
| Min rate   | CO                | ppm                       | CO <sub>2</sub>    | %   | CO/CO <sub>2</sub> |
| Where possible, has a flue integrity check been undertaken in accordance with manufacturers' instructions, and readings are correct?*              |                   |                           |                    | yes |                    |
| Gas rate:  | m <sup>3</sup> /h | OR                        | ft <sup>3</sup> /h |     |                    |
| Were parts fitted? <small>delete as appropriate</small>  | Yes               | No                        |                    |     |                    |
| Parts fitted:  |                   |                           |                    |     |                    |
| System inhibitor concentration has been checked and appropriate action taken, in accordance with BS 7593 and boiler manufacturers' instructions. * |                   |                           |                    | yes | n/a                |
| Comments:  |                   |                           |                    |     |                    |
| Signature:   |                   |                           |                    |     |                    |

\*A System inhibitor efficacy test is required on every annual service in accordance with the manufacturers' instructions and BS 7593. It is only acceptable to not have undertaken this if the service engineers attendance visit was in between annual services to attend a non-water facing component.

| SERVICE/INTERIM WORK ON BOILER <small>delete as appropriate</small>  |                   |                           |                    |     | Date:              |
|--|-------------------|---------------------------|--------------------|-----|--------------------|
| Engineer name:   |                   | Company name:             |                    |     |                    |
| Telephone N°:  |                   | Gas Safe registration N°: |                    |     |                    |
| Max rate   | CO                | ppm                       | CO <sub>2</sub>    | %   | CO/CO <sub>2</sub> |
| Min rate   | CO                | ppm                       | CO <sub>2</sub>    | %   | CO/CO <sub>2</sub> |
| Where possible, has a flue integrity check been undertaken in accordance with manufacturers' instructions, and readings are correct?*              |                   |                           |                    | yes |                    |
| Gas rate:  | m <sup>3</sup> /h | OR                        | ft <sup>3</sup> /h |     |                    |
| Were parts fitted? <small>delete as appropriate</small>  | Yes               | No                        |                    |     |                    |
| Parts fitted:  |                   |                           |                    |     |                    |
| System inhibitor concentration has been checked and appropriate action taken, in accordance with BS 7593 and boiler manufacturers' instructions. * |                   |                           |                    | yes | n/a                |
| Comments:  |                   |                           |                    |     |                    |
| Signature:   |                   |                           |                    |     |                    |

\*A System inhibitor efficacy test is required on every annual service in accordance with the manufacturers' instructions and BS 7593. It is only acceptable to not have undertaken this if the service engineers attendance visit was in between annual services to attend a non-water facing component.

| SERVICE/INTERIM WORK ON BOILER <small>delete as appropriate</small>  |                   |                           |                    |     | Date:              |
|--|-------------------|---------------------------|--------------------|-----|--------------------|
| Engineer name:   |                   | Company name:             |                    |     |                    |
| Telephone N°:  |                   | Gas Safe registration N°: |                    |     |                    |
| Max rate   | CO                | ppm                       | CO <sub>2</sub>    | %   | CO/CO <sub>2</sub> |
| Min rate   | CO                | ppm                       | CO <sub>2</sub>    | %   | CO/CO <sub>2</sub> |
| Where possible, has a flue integrity check been undertaken in accordance with manufacturers' instructions, and readings are correct?*              |                   |                           |                    | yes |                    |
| Gas rate:  | m <sup>3</sup> /h | OR                        | ft <sup>3</sup> /h |     |                    |
| Were parts fitted? <small>delete as appropriate</small>  | Yes               | No                        |                    |     |                    |
| Parts fitted:  |                   |                           |                    |     |                    |
| System inhibitor concentration has been checked and appropriate action taken, in accordance with BS 7593 and boiler manufacturers' instructions. * |                   |                           |                    | yes | n/a                |
| Comments:  |                   |                           |                    |     |                    |
| Signature:   |                   |                           |                    |     |                    |

\*A System inhibitor efficacy test is required on every annual service in accordance with the manufacturers' instructions and BS 7593. It is only acceptable to not have undertaken this if the service engineers attendance visit was in between annual services to attend a non-water facing component.

\* All installations in England and Wales must be notified to Local Authority Building Control (LABC) either directly or through a Competent Persons Scheme. A Building Regulations Compliance Certificate will then be issued to the customer.

© Heating and Hotwater Industry Council (HHIC)



www.centralheating.co.uk

## FLOWCHART FOR CO LEVEL AND COMBUSTION RATIO CHECK ON COMMISSIONING A CONDENSING BOILER

### Important Preliminary Information on Checks

The air gas ratio valve is factory-set and must not be adjusted DURING COMMISSIONING.

If the boiler requires conversion to operate with a different gas family (e.g. conversion from natural gas to LPG) separate guidance is provided with the conversion kit supplied and this must be followed.

#### PRIOR TO CO LEVEL AND COMBUSTION RATIO CHECK

The installation instructions must have been followed, gas type verified and gas supply pressure / gas rate checked as required prior to commissioning.

As part of the installation process, ESPECIALLY WHERE A FLUE HAS BEEN FITTED BY PERSONS OTHER THAN THE BOILER INSTALLER, visually check the integrity of the whole flue system to confirm that all components are correctly assembled, fixed and supported. Check that maximum flue lengths have not been exceeded and all guidance has been followed (e.g. Gas Safe Register Technical Bulletin (TB) 008 where chimney/flues are in voids).

The ECGA should be of the correct type, as specified by BS EN 50379-3:2012.

Prior to its use, the ECGA should have been maintained and calibrated as specified by the manufacturer. The installer must have the relevant competence for use of the analyser.

Check and zero the analyser IN FRESH AIR in accordance with the analyser manufacturer's instructions.

#### KEY:

**CO** = carbon monoxide

**CO<sub>2</sub>** = carbon dioxide

**O<sub>2</sub>** = oxygen

**Combustion Ratio** = The CO reading measured in ppm divided by the CO<sub>2</sub> reading first converted to ppm

**ppm** = parts per million

**GS(I&U)R** = Gas Safety (Installation and Use) Regulations

**IMPORTANT:** Ensure boiler is in normal operation with a heat demand before setting Maximum / Minimum rate function.

#### Setting to Maximum Rate:

1. Hold "MODE" & "RESTART" buttons together for more than 5s
2. Last 3 faults will be shown
3. SH shown, press "RESTART" button
4. Burner will run for 10 minutes at maximum rate
5. Press "RESTART" to exit Maximum Rate mode

#### Setting to Minimum Rate:

1. Hold "MODE" & "RESTART" buttons together for more than 5s
2. Last 3 faults will be shown
3. SH shown, press "MODE" button
4. SL shown, press "RESTART"
5. If the Return Temperature is under 40°C then the burner will run at maximum rate for 30s before ramping down to minimum rate over 60s.
6. If the Return Temperature is over 40°C then the burner will ramp down to minimum rate over 60s.
7. Burner will run for 10 minutes at minimum rate
8. Press "RESTART" to exit Minimum Rate mode

 **IMPORTANT:** Do not disconnect the boiler's mains power while it is in service mode (maximum/minimum rate).

If the boiler is turned off while in service mode, it will automatically resume the interrupted service mode when powered back on and will complete after 10 minutes.

To manually finish the service mode, wait at least 60 seconds after an electrical supply has been reconnected, then begin the service mode setup procedure again and exit as the instruction provided.

## Section 6 - Benchmark to Commissioning

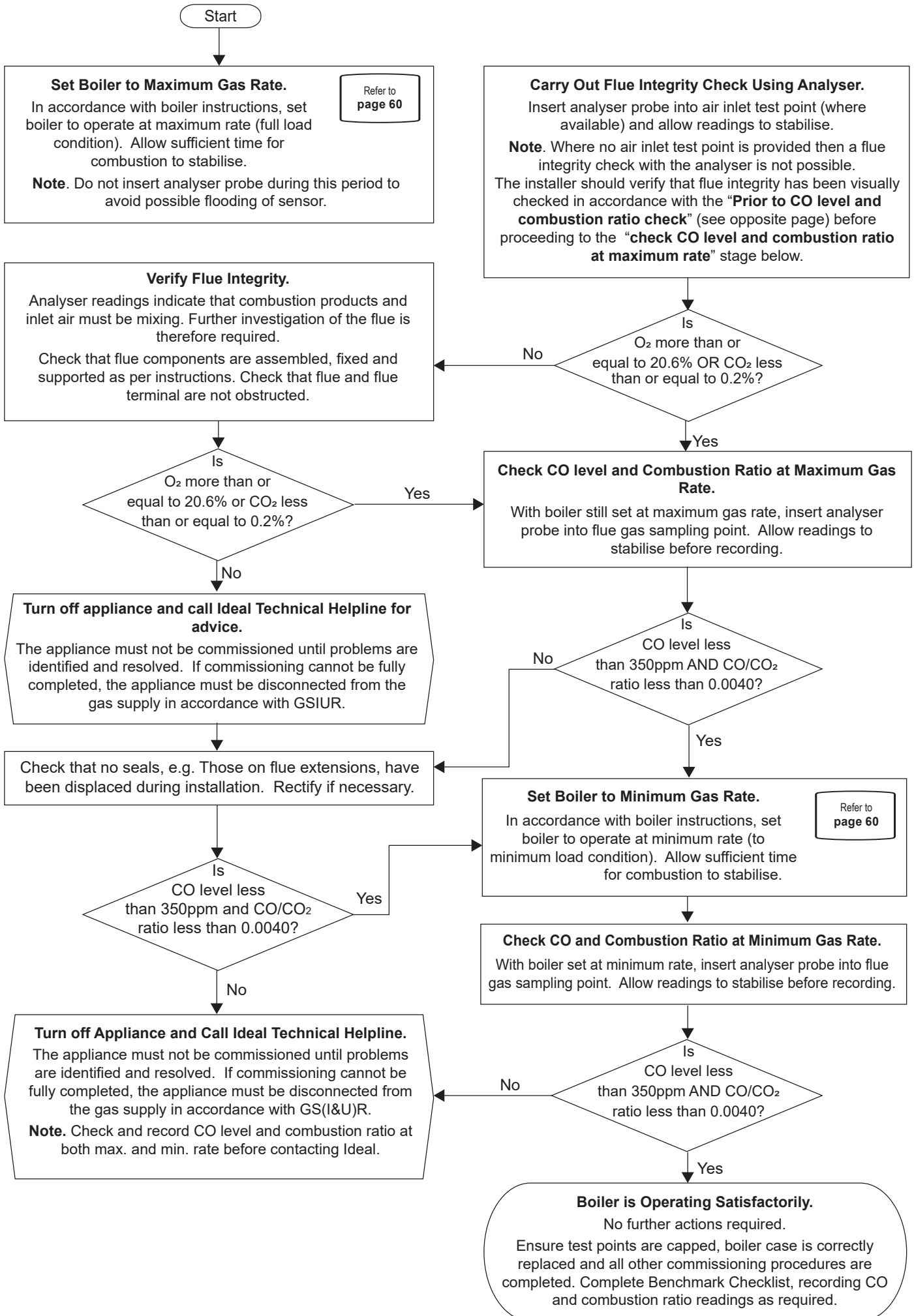



At Ideal Heating we take our environmental impact seriously, therefore when installing any Ideal Heating product please make sure to dispose of any previous appliance in an environmentally conscious manner. Households can contact their local authority to find out how. See <https://www.gov.uk/managing-your-waste-an-overview> for guidance on how to efficiently recycle your business waste.

### Technical Training

Our Expert Academy offer a range of training options designed and delivered by our experts in heating. For details please visit: [expert-academy.co.uk](http://expert-academy.co.uk)

Ideal Boilers Ltd., pursues a policy of continuing improvement in the design and performance of its products. The right is therefore reserved to vary specification without notice.

Ideal is a trademark of Ideal Boilers.

Registered Office

Ideal Boilers Ltd., National Avenue, Hull, East Yorkshire, HU5 4JB

Tel 01482 492251 Fax 01482 448858

Registration No. London 322 137

EU Authorised Representative:

Atlantic SFDT

44 Boulevard des Etats-Unis, 85 000 La Roche-Sur-Yon, France

+33 (0)2 51 44 34 34

Ideal Technical Helpline: 01482 498663

Ideal Consumer Helpline: 01482 498660

Ideal Parts: 01482 498665

[idealheating.com](http://idealheating.com)

**ideal**  
HEATING