

NEW BUILD PRODUCT GUIDE

BOILERS | HEAT PUMPS | CYLINDERS



2024/2025

atlantic

ideal
HEATING

G **GLEDHILL**

CONTENTS

An aerial photograph of a residential development. The houses are primarily brick with white window frames and doors. Some houses have bay windows. A central road curves through the development, with several cars parked. The background shows more houses and greenery under a clear sky.

Together, **Ideal Heating**, **Gledhill**, and **Atlantic** form an unbeatable alliance, providing new build developers with a comprehensive suite of heating and hot water solutions. **Welcome to the perfect partnership for a warm and efficient future.**



IDEAL HEATING 4

Logic Air Heat Pump	6
HP290 Monobloc Heat Pump	10
Pre-Plumbed Cylinders	12
Halo and Controllers	18
Alfea Extensa A.I. R32	22
Boilers	24
Halo	30
Thermstore Cylinders	34
POD Indirect	38
POD Direct	39
Industry Leading Customer Service	40
Developer Connect	41
Ideal Design Service	42
First Class Industry Training	43
Installation & Flue Accessories	44

GLEDHILL 50

Stainless Platinum Pre-plumbed Direct	52
Stainless Platinum Pre-plumbed Indirect	53
Stainlesslite Platinum Direct	54
Stainlesslite Platinum Indirect	55
Stainlesslite Pre-plumbed Indirect	56
Stainlesslite System Plus Indirect	57
Stainlesslite System Ready Indirect	58
Gledhill Cylinder Washing Machine Frame	59

ATLANTIC 60

Sokio Horizontal	62
Sokio Vertical	63
Furno	64
Agilia IO	65
Sensis	66
Atlantic Chrome	67
Calypso	68
Cozytouch	70

MARKET LEADERS IN HEATING & HOT WATER



At Ideal Heating we believe in making things as easy as possible. That's why we combine ease of installation with high levels of quality and reliability. We rigorously test each and every one of our products with dozens of safety and reliability checks before they leave our Yorkshire based factory.

Our range of boilers has been awarded the Good Housekeeping reader recommended status eight years in a row.

Consistently the market leaders in the New Build segment for boilers.

LOGIC AIR



Scan me for
full technical
specification

HEAT PUMP 4 5 8 10 kW

4kW - AH750664 | 5kW - AH750665 | 8kW - AH750666 | 10kW - AH750667

The Logic Air heat pump range is our new range of monobloc heat pumps, offering great efficiencies both in heating and hot water. The Logic Air is designed to deliver efficient, simple and reliable low carbon heating in homes throughout the UK.



KEY FEATURES

- ✓ Designed for the UK climate
- ✓ Quiet operation
- ✓ Up to 60°C hot water in rain, ice and snow
- ✓ Flexible warranty
- ✓ 364 day a year UK customer service
- ✓ SCOP rating up to 519%*
- ✓ R32 refrigerant

A+++ EFFICIENCY RATING

PCDB INDEX

Flow Temp	Logic Air 4kW	Logic Air 5kW	Logic Air 8kW	Logic Air 10kW
Flow temp 35°C	107447	107235	106762	106754
Flow temp 45°C	107446	107234	106761	106753
Flow temp 55°C	107445	107233	106760	106752

*Performance data in accordance with EN 14825, EN 12102-1, EN 14511. The energy efficiency provided may not correspond to the actual energy once installed in a building, as the efficiency is influenced by other factors such as heat loss in the distribution system and the capacity of the products in relation to building size and characteristics.

OVERVIEW

Taking the learnings from the award winning Logic boiler, the Logic Air heat pump integrates seamlessly with UK homes, partnered with our best in class pre-plumbed hot water cylinder and our connected Halo Air room thermostat, the Logic Air is quick to install, easy to commission and simple to use.

Our new heat pumps are supported by our industry leading customer service and warranty team which is based in the UK and is open 364 days a year, providing customer service and technical support.

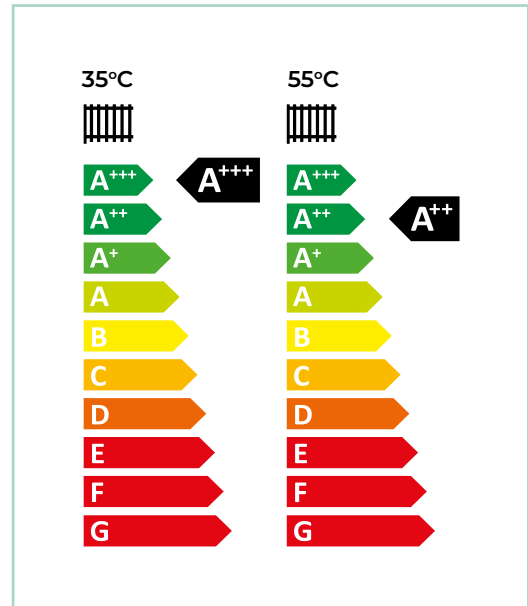

CLEARANCES & DIMENSIONS

All Dimensions in mm

	4kW & 5kW	8kW & 10kW
A	798	1008
B	518	518
C	1095	1095
D	499	499
E	518	518
F	558	558
G	688	688
H	516	516
I	80	80
J	184	184
K	140	140
L	95	95
M	84	84
N	48	48
O	90	90
P	103	105

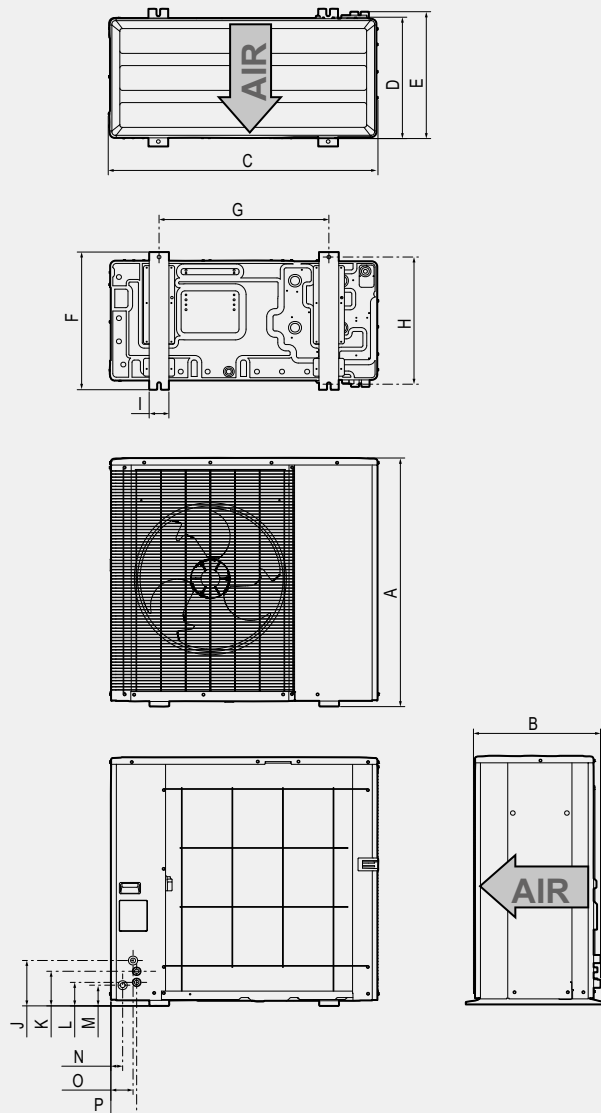

LOGICAL SOLUTIONS



EFFICIENCY

The efficiency rating of a heat pump determines how much it costs to use. A high efficiency rating means it costs less to operate.

The Logic Air has one of the highest efficiency ratings in the UK, rated at 5.19 (Coefficient of performance) making it one of the most economical heat pumps on the market.



SOUND AND DIMENSIONS

Sound and dimensions are important, not just for our customers comfort level, but to MCS and the Planning office. The Logic Air is quiet and compact. Small enough for permitted development with the local planning authority and cutting edge acoustic technology makes its low sound levels amongst the best in the market.



FAST HEAT PUMP INSTALLATION

Our Logic Air heat pump, pre-plumbed cylinders and Halo Air room thermostat are designed to be amongst the fastest heat pumps to install. Factory fitted components, click and connect wiring terminals reduce installation time and improve installation reliability.



HOT WATER

Ensuring enough hot water can be generated efficiently and quickly is crucial to a heat pump system. The Logic Air pre-plumbed hot water cylinder can generate hot water faster than some of the most popular heat pump DHW cylinders in the UK, saving money and energy.



SIMPLE TO USE, APP CONTROL AND ONLINE HEALTH CHECKS

Halo Air is a new generation of heat pump thermostats connected to your phone with options to connect to our customer service team. Halo Air automatically makes your heating system more efficient, enables remote control and 24/7 system performance data. All wrapped up in an easy to use controller.



EASIER TO SIGHT

With a '0' ozone depletion rating and low global warming potential, R32 is safe, efficient and reliable.



Scan me
to watch our
case study



HP290 MONOBLOC



Scan me for
full technical
specification

HEAT PUMP 4.5 6 8 10 12 14 kW

4.5kW - 241486 | 6kW - 241487 | 8kW - 241488 | 10kW - 241489 | 12kW - 241490 | 14kW - 241491

The HP290 monobloc heat pump offers a low-GWP refrigerant with high efficiencies.

KEY FEATURES

- ✓ Low GWP R290 refrigerant
- ✓ Highly efficient: SCOP up to 500%*
- ✓ Intuitive control: smart weather compensating controls
- ✓ Low carbon refrigerant: zero ozone depletion and low global warming potential
- ✓ Smart grid and solar PV compatible
- ✓ Monobloc technology enables easy installation and servicing
- ✓ Domestic hot water: hot, efficient and fast reheat times with the ideal heat pump cylinder range
- ✓ Flow temperatures up to 75°C



A+++ EFFICIENCY RATING

PCDB INDEX

Flow Temp	Hp290 4.5kW	Hp290 6kW	HP290 8kW	HP290 10kW	HP290 12kW	HP290 14kW
Flow temp 35°C	107965	107973	107981	107989	107997	108005
Flow temp 45°C	107964	107972	107980	107988	107996	108004
Flow temp 55°C	107963	107971	107979	107987	107995	108003

OVERVIEW

The HP290 can provide efficient heating and hot water throughout the year by utilising our pre-plumbed and pre-wired cylinder. The system offers our users an aesthetically pleasing heating solution and when paired with Halo Lite RF, a great user experience.

Our heat pumps are supported by our industry leading customer service and warranty team which is based in the UK and is open 364-days a year, providing customer service and technical support.

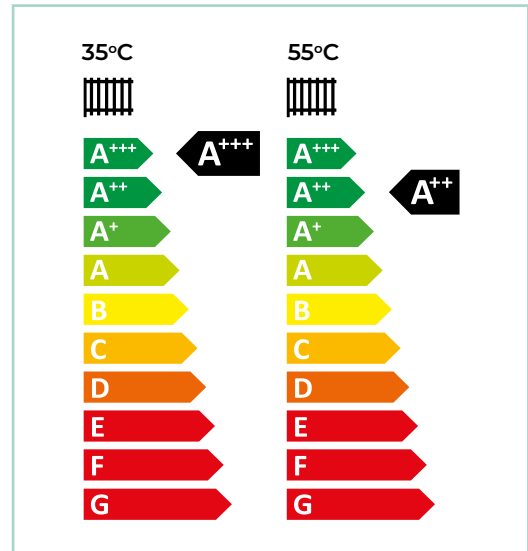

CLEARANCES & DIMENSIONS

All Dimensions in **mm**

	4.5kW & 6kW	8kW - 14kW
A	717	865
B	1299	1385
C	426	523
D	375	456
E	121	192
F	644	656
G	379	363
H	71	68
I	161	145
J	91	100
K	91	129

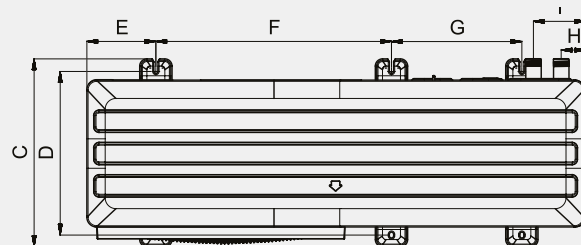
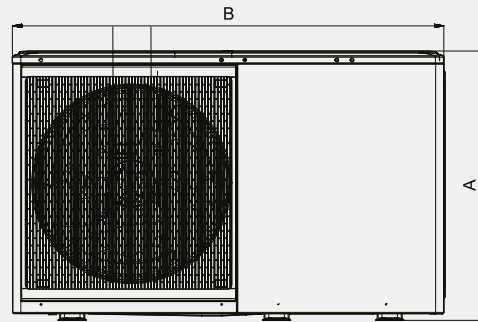
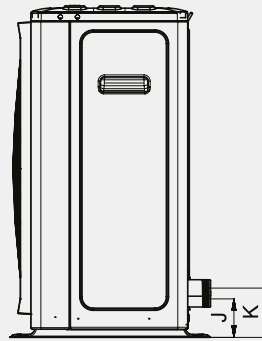

*Performance data in accordance with EN 14825 : 2016, EN 12102, EN 14511 : 2018. The energy efficiency provided may not correspond to the actual energy once installed in a building, as the efficiency is influenced by other factors such as heat loss in the distribution system and the capacity of the products in relation to building size and characteristics.

LOGIC AIR AND HP290

PRE-PLUMBED CYLINDER



Scan me for
full technical
specification

Our stainless steel pre-plumbed hot water cylinders combine efficiency with practicality. Designed and manufactured in the UK and boasting industry leading reheat times, our cylinders have been designed to store and generate hot water efficiently using a heat pump.



**DESIGNED
TO FIT IN UK
HOMES**

KEY FEATURES

- ✓ 60°C DHW
- ✓ 28.5% energy savings*
- ✓ Built in low loss header or buffer tank
- ✓ 49% faster reheat times*
- ✓ Fully pre-plumbed and pre-wired



The Logic Air pre-plumbed cylinder range comes in **16 variants** from **single zone** 150 Litre to **two zone** 300 Litre

NEW COMBINED DHW AND BUFFER CYLINDERS

The new pre-plumbed cylinder range includes models with an integrated buffer. Housing the DHW cylinder and separate buffer tank in the same case, alongside pre-wired circulation pumps and all the standard pre-plumbing components.

NEW LOW LOSS HEADER

Our new pre-plumbed low loss header cylinders de-couple the heating system from the heat pump protecting flow rates and enabling two zone control.

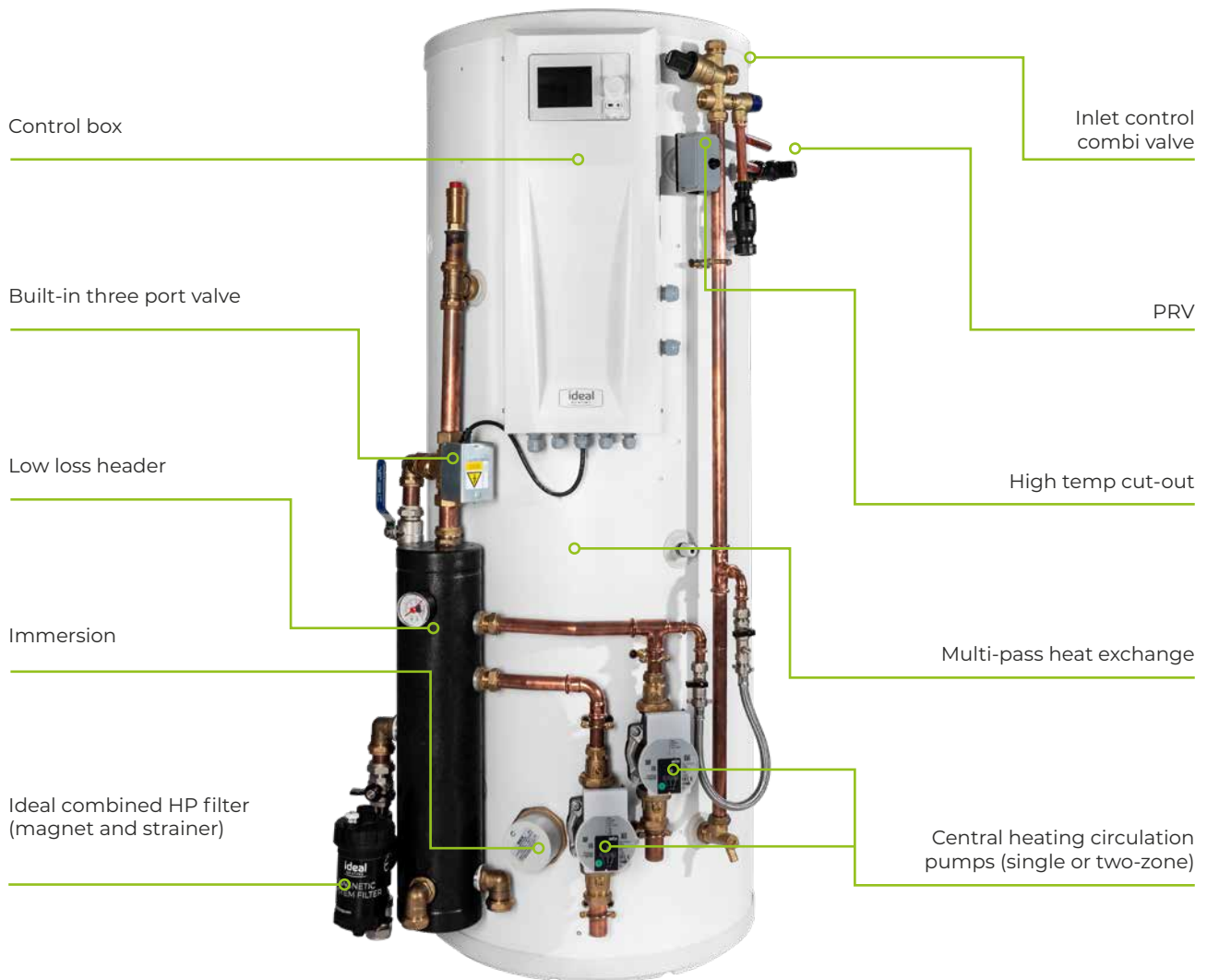

*Performance figures from for HWA 002:2020 heat pump test results

LOGIC AIR & HP290

LOGIC AIR TWO ZONE PRE-PLUMBED CYLINDERS WITH LOW LOSS HEADER

LOGIC AIR DHW CYL PP 210 CBOX LL 2Z SL	LOGIC AIR DHW CYL PP 210 CBOX LL 2Z	LOGIC AIR DHW CYL PP 250 CBOX LL 2Z	LOGIC AIR DHW CYL PP 300 CBOX LL 2Z
236205	236200	236201	236202

LOGIC AIR SINGLE ZONE PRE-PLUMBED CYLINDERS

LOGIC AIR DHW CYL PP 150 CBOX 1Z SL	LOGIC AIR DHW CYL PP 180 CBOX 1Z SL	LOGIC AIR DHW CYL PP 150 CBOX 1Z	LOGIC AIR DHW CYL PP 180 CBOX 1Z
236203	236204	236198	236199

LOGIC AIR SINGLE ZONE PRE PLUMBED CYLINDER WITH INTEGRATED BUFFER

DHW CYL PP 180 CBOX BUFF 1Z	DHW CYL PP 210 CBOX BUFF 1Z	DHW CYL PP 250 CBOX BUFF 1Z	DHW CYL PP 300 CBOX BUFF 1Z
236206	236208	236210	236212

LOGIC AIR TWO ZONE PRE-PLUMBED CYLINDERS WITH INTEGRATED BUFFER

DHW CYL PP 180 CBOX BUFF 2Z	DHW CYL PP 210 CBOX BUFF 2Z	DHW CYL PP 250 CBOX BUFF 2Z	DHW CYL PP 300 CBOX BUFF 2Z
236207	236209	236211	236213

HP290 TWO ZONE PRE-PLUMBED CYLINDERS WITH LOW LOSS HEADER

HP290 DHW CYL PP 210 CBOX LL 2Z SL	HP290 DHW CYL PP 210 CBOX LL 2Z	HP290 DHW CYL PP 250 CBOX LL 2Z	HP290 DHW CYL PP 300 CBOX LL 2Z
240129	240124	240125	240126

HP290 SINGLE ZONE PRE-PLUMBED CYLINDERS

HP290 DHW CYL PP 150 CBOX 1Z SL	HP290 DHW CYL PP 180CBOX 1Z SL	HP290 DHW CYL PP 150 CBOX 1Z	HP290 DHW CYL PP 180 CBOX 1Z
240127	240128	240122	240123

HP290 SINGLE ZONE PRE-PLUMBED DHW CYLINDERS WITH INTEGRATED BUFFER

HP290 DHW CYL PP 180 CBOX BUFF 1Z	HP290 DHW CYL PP 210 CBOX BUFF 1Z	HP290 DHW CYL PP 250 CBOX BUFF 1Z	HP290 DHW CYL PP 300 CBOX BUFF 1Z
240130	240132	240134	240136

HP290 TWO ZONE PRE-PLUMBED DHW CYLINDERS WITH INTEGRATED BUFFER

HP290 DHW CYL PP 180 CBOX BUFF 2Z	HP290 DHW CYL PP 210 CBOX BUFF 2Z	HP290 DHW CYL PP 250 CBOX BUFF 2Z	HP290 DHW CYL PP 300 CBOX BUFF 2Z
240131	240133	240135	240137

LOGIC AIR AND HP290



Scan me for full technical specification

SINGLE ZONE PRE-PLUMBED CYLINDER

The single zone pre-plumbed cylinder range offer super fast reheat times thanks to the highly efficient multi-coil heat exchanger. They are also really easy to install since they come pre-plumbed and pre-wired ready for installation with the Logic Air or HP290 heat pump.

INDUSTRY LEADING REHEAT TIMES

- KEY FEATURES**
- ✓ Fully pre-plumbed and pre-wired
 - ✓ Control box included
 - ✓ 25 year warranty*
 - ✓ UK dimensions: standard & slimline
 - ✓ Highly efficient multi-coil heat exchanger



LOGIC AIR AND HP290



Scan me for
full technical
specification

TWO ZONE PRE-PLUMBED CYLINDER

The two zone pre-plumbed cylinders include a lowloss header pre-plumbed onto the cylinder, decoupling the heating system from the heat pump, ensuring optimal flow and two zone control.



**DESIGNED
TO FIT IN UK
HOMES**

KEY FEATURES

- ✓ Fully pre-plumbed and pre-wired
- ✓ Control box included
- ✓ 25 year warranty*
- ✓ UK dimensions: standard & slimline
- ✓ Highly efficient multi-coil heat exchanger

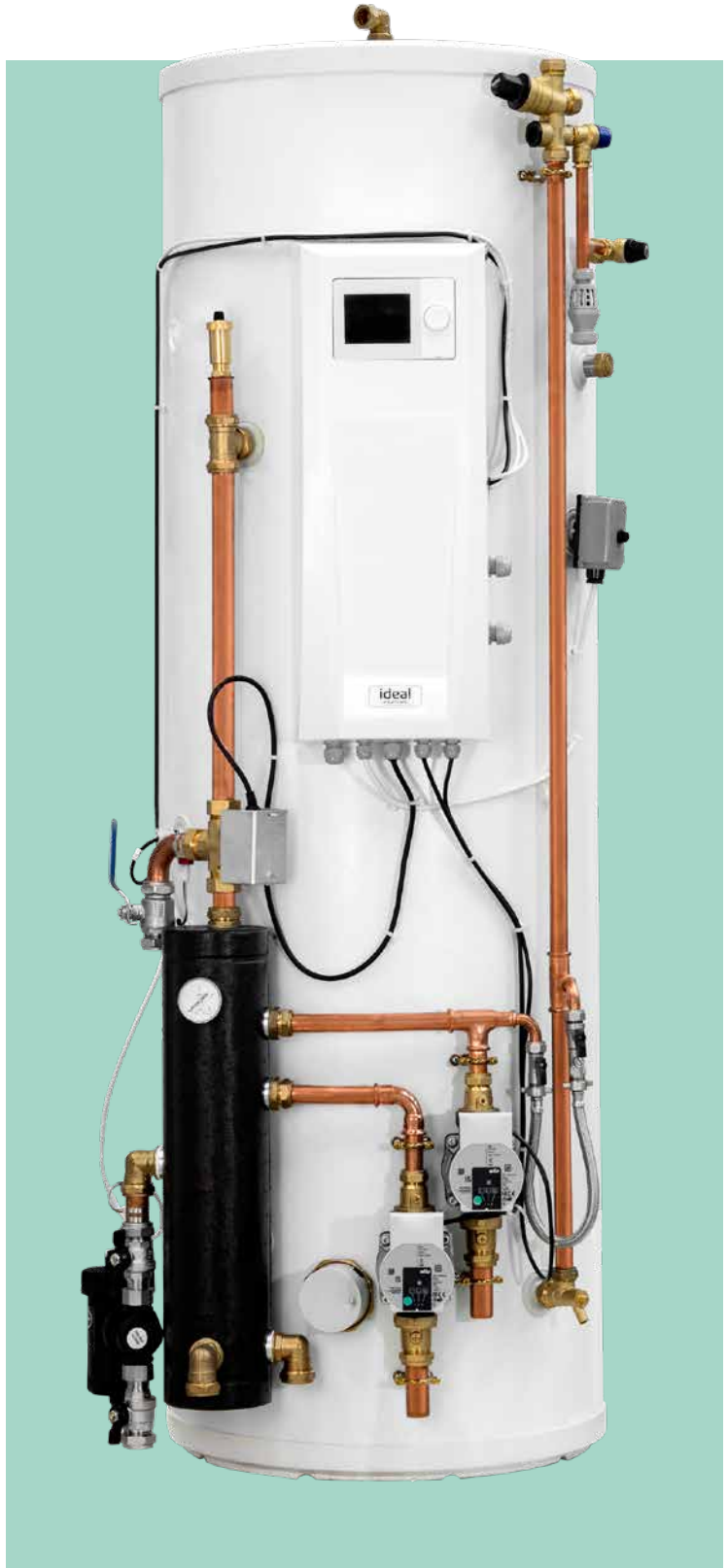

LOGIC AIR AND HP290



Scan me for full technical specification

PRE-PLUMBED CYLINDER WITH INTEGRATED BUFFER

The pre-plumbed cylinder range includes models with an integrated buffer. Housing the DHW cylinder and separate buffer tank in the same case, alongside pre-wired circulation pumps and all the standard pre-plumbing components.



INTEGRATED BUFFER

KEY FEATURES

- ✓ Fully pre-plumbed and pre-wired
- ✓ Control box included
- ✓ Integrated buffer
- ✓ Includes circulation pumps
- ✓ Highly efficient multi-coil heat exchanger

AVAILABLE IN SINGLE ZONE AND TWO ZONE



HALO AIR

ROOM THERMOSTAT



Scan me for full technical specification

Halo Air is a programmable room thermostat, based on the current Ideal Halo platform that is designed and developed to work seamlessly with the new Logic Air monobloc heat pump.

KEY FEATURES

- ✓ Designed for Logic Air
- ✓ Easy to install
- ✓ Full heating and hot water control
- ✓ Load compensating control

HALO LITE RF 221528

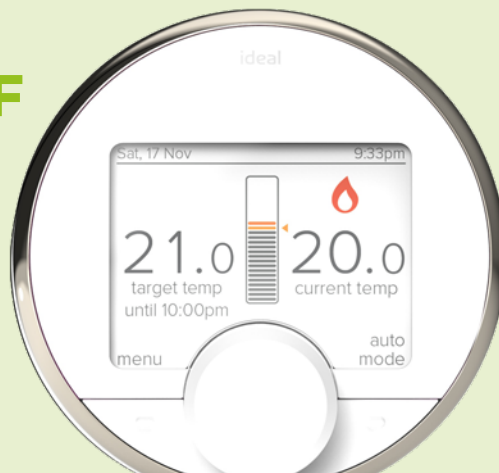

The Ideal Halo Lite OpenTherm Wired Combi is a single zone combi programmable room Halo Lite comes with the same features and benefits as the Halo Lite RF, but in a wired configuration, reducing the need for battery maintenance.

*2 year parts and labour warranty available when registered within 30 days of installation. Terms and conditions apply.

HALO AIR RF 234790



Halo Air RF is a wireless programmable room thermostat designed specifically to work with Logic Air.

Halo Air offers fast, flexible and intelligent wireless technology and is packed with features that enable simple and easy heating and hot water control.

*2 year parts and labour warranty available when registered within 30 days of installation. Terms and conditions apply.

HALO AIR **WI-FI** 234819



Halo Air Wi-Fi is engineered specifically to work with Logic Air heat pumps and allows flexible control of heating and hot water with the intuitive Halo app, which can be connected through smart home devices like Amazon Alexa and Google Home.

It's simple to install, straightforward for everyone to use, no matter where they are.

*2 year parts and labour warranty available when registered within 30 days of installation. Terms and conditions apply.

HALO AIR **2-ZONE RF** 234792



Halo Air 2-Zone RF incorporates an additional programmable room thermostat with the extra functionality of controlling the temperature of a second zone.

*2 year parts and labour warranty available when registered within 30 days of installation. Terms and conditions apply.

HALO AIR **2-ZONE WI-FI** 234791



Halo Air 2-Zone Wi-Fi incorporates an additional programmable room thermostat with the extra functionality of controlling the temperature of a second zone.

*2 year parts and labour warranty available when registered within 30 days of installation. Terms and conditions apply.

LOGIC AIR

CONTROL BOX

235797

The Logic Air control box is the central hub for the heat pump system, linking the heat pump to your heating and hot water cylinder. It enables in depth control, scheduling, connectivity and performance diagnostics.

INBUILT HEAT PUMP CONTROLLER

Our inbuilt controller uses tried and tested technology to keep you warm efficiently. From scheduling to diagnostics our controller gives you control and transparency.

QUICK START SET UP

Our new quick start menu makes commissioning fast, easy and accurate. In just a few steps the heat pump can be up and running and tuned to its most efficient parameters.

CONNECTIVITY

The Logic Air control box is compatible with Halo Air, Link Cellular heat pump diagnostics and 3rd party thermostats, giving you access to online control, scheduling and remote diagnostics from anywhere in the world.



SMART GRID COMPATIBLE / SOLAR PV COMPATIBLE

The Logic Air control box is smart grid ready and can connect to solar PV, enabling smarter ways of powering heating and hot water.

PERFORMANCE DIAGNOSTICS

The Logic Air control box gives you access to the efficiency of the householders heating system, helping them to understand the health of their heat pump system at a glance.

HP290

CONTROL BOX

239386

The HP290 control box is a hub for a HP290 heat pump system. By bringing all electrical connections to one central location, the HP290 control box enables a fast and simple installation experience.

The HP290 Control Box incorporates the HP290 Controller into a central indoor wiring centre complete with all electrical components providing a quick and simple installation process utilising one cable between the control box and HP290 monobloc heat pump.



HP290

CONTROLLER

241519

The HP290 controller offers a budget friendly and flexible option for those not looking to purchase the HP290 Control Box.

The HP290 controller provides the controls and user interface for the HP290 heat pump without the electrical ancillaries, indoor wiring centre or control box.



ALFEA EXTENSA

A.I. R32



Scan me for full technical specification

HEAT PUMP 5 6 8 10 kW

5kW - AH526349 | 6kW - AH526346 | 8kW - AH526347 | 10kW - AH526348

The Ideal Alfea uses intelligent technology to redefine how we heat our homes. Our new refrigerant balances industry-leading efficiencies with an ultra-low environmental impact, using patented technology to match performance with reliability.

KEY FEATURES

- ✓ Suitable for new build, social housing and retrofit
- ✓ ERP A+++
- ✓ Quiet noise level: 35 dB(A)
- ✓ 474% rated efficiency (COP)
- ✓ R32 refrigerant



ENGINEERED FOR RELIABILITY

The Alfea A.I. range has a patented coaxial heat exchanger, a unique technology that has been developed to maximise the heat pump's performance.

This enables us to achieve unrivalled reliability and drives up efficiency. Our heat exchanger uses large water ways and tube in tube technology to ensure really good flow rates. We then capture all the energy from the heat exchanger by immersing it into our buffer tank and combining it with our backup immersion to speed up installation time and free up space.

The Ideal Alfea heat pump is redefining how we heat our homes, providing low carbon heating that is efficient, reliable, and effortlessly simple to use.

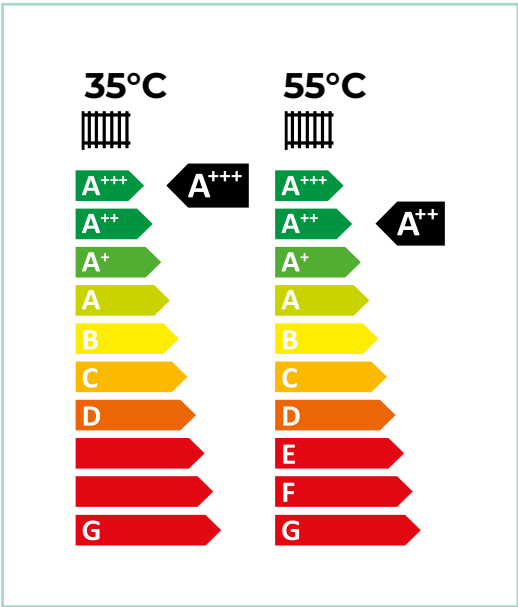

A+++ EFFICIENCY RATING

CLEARANCES & DIMENSIONS

All Dimensions in **mm**

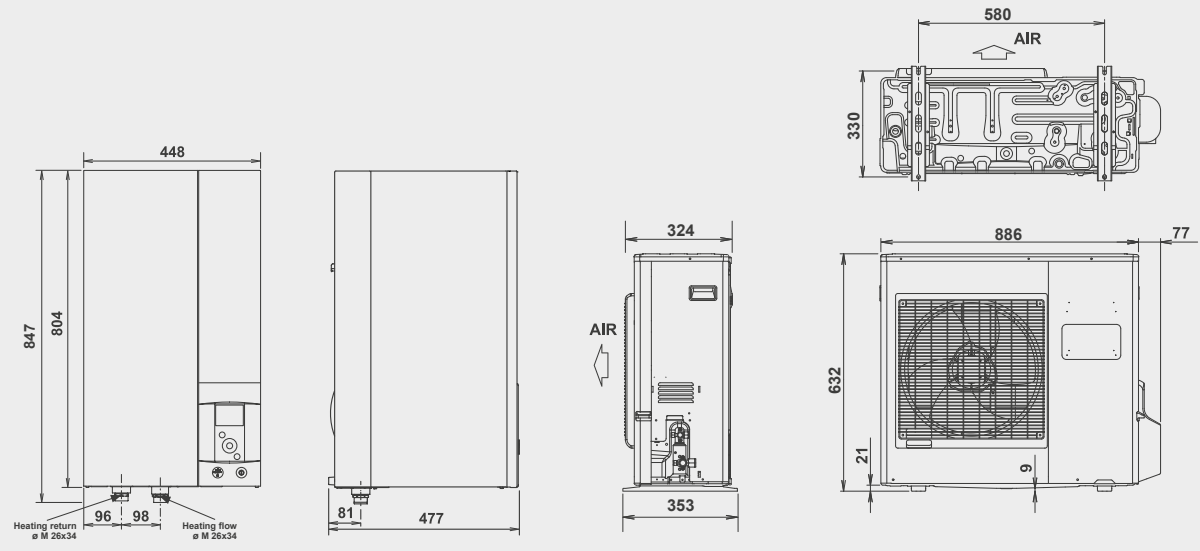

LOGIC COMBI ESP1

BOILER 24 30 35 kW



Scan me for full technical specification

OVERVIEW

Complementing the existing Logic range, the Logic Combi ESP1 design is optimised for compliance following appropriate SAP process.

A quick installation is assured thanks to a wide range of flueing options, fast fix flue turret connections and no need for compartment ventilation allowing this product to be installed out of sight in a standard kitchen cupboard†.

The Logic Combi ESP1 is fully modulating, built with tried and tested technology.

KEY FEATURES

- ✓ Compact cupboard fit
- ✓ Easy to see pressure gauge
- ✓ Opentherm ready
- ✓ Flue variants
- ✓ LPG conversion††
- ✓ NOx class 6
- ✓ ErP compliant
- ✓ High SAP ratings, making it easier to achieve your required TER
- ✓ Compatible with Halo Controls



2 YEARS WARRANTY*

SAP INDEX	PRODUCT CODE	BRAND NAME	MODEL NAME	NOx Emissions (mg/kWh)	NOx Class
17955	215428	Ideal Heating	Logic Combi ESP1 24	28	Class 6
17956	215429	Ideal Heating	Logic Combi ESP1 30	25	Class 6
17929	215430	Ideal Heating	Logic Combi ESP1 35	30	Class 6

*2 year warranty subject to Terms and Conditions. † Please check kitchen cupboard size prior to installation. †† LPG Conversion kit available for 30kW & 35kW models.

LOGIC CODE COMBI ESP1

BOILER 26 33 38 kW



Scan me for full technical specification

OVERVIEW

Developed using state of the art advanced boiler technology, the Code Combi ESP1 features a built-in stainless steel passive flue gas heat recovery unit located in the flue exit, which cleverly picks up and recycles waste energy that would have normally been lost through the flue terminal.

This energy is collected and used to warm up the cold hot water supply. This supply, then flows into the plate heat exchanger, where the desired temperature is reached.

KEY FEATURES

- ✓ Compact cupboard fit
- ✓ Easy to see pressure gauge
- ✓ Opentherm ready
- ✓ Flue variants
- ✓ LPG conversion†
- ✓ NOx class 6
- ✓ ErP compliant
- ✓ Passive flue gas heat recovery unit
- ✓ Compatible with Halo Controls



2 YEARS WARRANTY*

SAP INDEX	PRODUCT CODE	BRAND NAME	MODEL NAME	NOx Emissions (mg/kWh)	NOx Class
18121	215735	Ideal Heating	Logic Code Combi ESP1 26	24	Class 6
18122	215736	Ideal Heating	Logic Code Combi ESP1 33	25	Class 6
18123	215737	Ideal Heating	Logic Code Combi ESP1 38	32	Class 6

†LPG Conversion kit available for 33kW & 38kW models. *2 year warranty subject to Terms and Conditions.

LOGIC HEAT

BOILER 12 15 18 24 30 kW



Scan me for full technical specification

OVERVIEW

Suitable for open vent and sealed systems, the Logic Heat boiler is straightforward to site and install. Benefiting from no compartment ventilation, compact fit, and a lightweight design means the boiler can be neatly installed out of sight into a kitchen cupboard†. Installers have the further choice of a neat direct rear flue option as required, helping to speed up the installation in retrofit situations even further.

High SEDBUK efficiency rated and capability of modulating down to 4.8kW**, the Logic Heat is highly efficient and easy to operate thanks to straightforward controls featuring a clear digital display.

KEY FEATURES

- ✓ Compact cupboard fit
- ✓ Rear flue output option
- ✓ Opentherm ready
- ✓ Flue variants
- ✓ LPG conversion††
- ✓ NOx class 6
- ✓ ErP compliant
- ✓ Reduced running costs due to class leading efficiency
- ✓ Compatible with Halo Controls



2 YEARS WARRANTY*

SAP INDEX	PRODUCT CODE	BRAND NAME	MODEL NAME	NOx Emissions (mg/kWh)	NOx Class
17955	215428	Ideal Heating	Logic Combi ESP1 24	28	Class 6
17956	215429	Ideal Heating	Logic Combi ESP1 30	25	Class 6
17929	215430	Ideal Heating	Logic Combi ESP1 35	30	Class 6

*2 year warranty subject to Terms and Conditions † Please check kitchen cupboard size prior to installation. †† LPG Conversion kit available for H18kW H24kW and H30kW models. ** (30kW only - 6.1kW).

LOGIC SYSTEM



Scan me for full technical specification

BOILER 15 18 24 30 kW

OVERVIEW

Available in a choice of four outputs - 15, 18, 24 and 30kW, the Logic System provides a dependable and efficient solution for new installations. Siting and installing a Logic System is hassle free thanks to a simple telescopic flue option.

Time saving fast fix flue turret connections and a wide range of alternative flueing solutions help to ensure the product is installed quickly and efficiently in virtually any domestic situation.

With a lightweight design, concealed connections at the base and no compartment ventilation required, the Logic System can be conveniently fitted out of sight into a standard kitchen cupboard†.



KEY FEATURES

- ✓ Compact cupboard fit
- ✓ Easy to see pressure gauge
- ✓ Opentherm ready
- ✓ Flue variants
- ✓ LPG conversion††
- ✓ NOx class 6
- ✓ ErP compliant
- ✓ Compatible with Halo Controls

2 YEARS WARRANTY*

SAP INDEX	PRODUCT CODE	BRAND NAME	MODEL NAME	NOx Emissions (mg/kWh)	NOx Class
19045	228352	Ideal Heating	Logic System S15	21	Class 6
19046	228353	Ideal Heating	Logic System S18	24	Class 6
19047	228354	Ideal Heating	Logic System S24	28	Class 6
19048	228355	Ideal Heating	Logic System S30	26	Class 6

*2 year warranty subject to Terms and Conditions. † Please check kitchen cupboard size prior to installation. †† LPG Conversion kit available for H18kW, H24kW and H30kW model.

LOGIC SYSTEM

BOILER 15 18 24 30 kW



Scan me for full technical specification

High ErP efficiency rating and easy to install, the Logic System range of appliances from Ideal Heating provide a simple and reliable solution for a wide variety of sealed domestic systems.

2 YEARS WARRANTY*

KEY FEATURES

- ✓ Compact cupboard fit
- ✓ Easy to see pressure gauge
- ✓ Opentherm ready
- ✓ Flue variants
- ✓ LPG conversion††
- ✓ NOx class 6
- ✓ ErP compliant
- ✓ Compatible with Halo Controls



**EASY TO
SEE PRESSURE
GAUGE**

OVERVIEW

Available in a choice of four outputs - 15, 18, 24 and 30kW, the Logic System provides a dependable and efficient solution for new installations. Siting and installing a Logic System is hassle free thanks to a simple telescopic flue option.

Time saving fast fix flue turret connections and a wide range of alternative flueing solutions help to ensure the product is installed quickly and efficiently in virtually any domestic situation.

With a lightweight design, concealed connections at the base and no compartment ventilation required, the Logic System can be conveniently fitted out of sight into a standard kitchen cupboard†.

The Logic System boiler provides simple heating control, all from a single compact appliance.

THE PERFECT HEAT ONLY SYSTEM

The Logic System boiler is the perfect match for the new Ideal Pre-Plumbed H cylinder. As with all Ideal products, you can be assured reliability is engineered, through quality design and testing, supported by a 25 year cylinder warranty.

Our range of pre-plumbed cylinders have been created specifically for the new build market. They offer a 'plug and play' solution which reduces installation time and standardises plumbing configuration across multiple dwelling sites.

SAP INDEX	PRODUCT CODE	BRAND NAME	MODEL NAME	NOx Emissions (mg/kWh)	NOx Class
19045	228352	Ideal Heating	Logic System S15	21	Class 6
19046	228353	Ideal Heating	Logic System S18	24	Class 6
19047	228354	Ideal Heating	Logic System S24	28	Class 6
19048	228355	Ideal Heating	Logic System S30	26	Class 6

CLEARANCES & DIMENSIONS

All Dimensions in mm

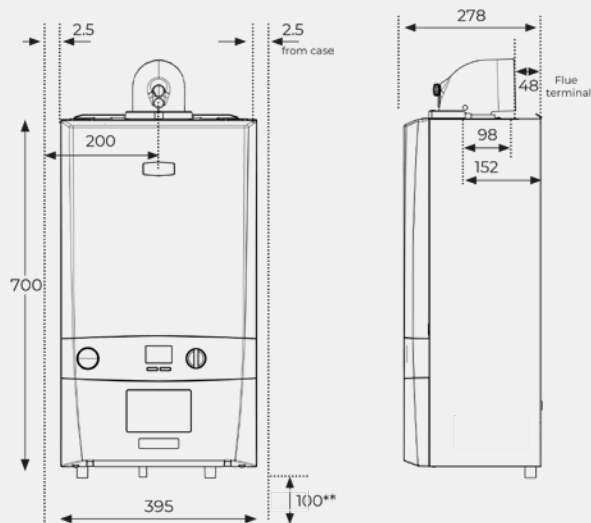

Note: The minimum front clearance when built into a cupboard is 5mm from the cupboard door but 450mm overall clearance with the cupboard door open is required for servicing.

**Bottom clearance after installation can be reduced to 5mm. However, 100mm is required for servicing.

*2 year warranty subject to Terms and Conditions. † Please check kitchen cupboard size prior to installation. †† LPG Conversion kit available for H18kW, H24kW and H30kW model.

LOGIC COMBI ESP1

BOILER MODEL	LOGIC COMBI ESP1			
	24	30	35	
SIZE	Casing dimensions (h w d)(mm)			
	Height	700	700	700
	Width	395	395	395
	Depth	278	278	278
	Weight (packed) kg	33.7	33.8	33.9
	Max installation weight kg	28.9	29.0	29.1
PERFORMANCE	CH output (kW) min/max mean 70°C	4.8 - 24.2	6.1 - 24.2	7.1 - 24.2
	CH output (kW) min/max mean 40°C	5.1 - 25.6	6.4 - 25.6	7.5 - 25.6
	DHW output (kW) max	24.2	30.3	35.3
	DHW flow rate l/min. 35°C rise	9.9	12.4	14.5
	SEDBUK (2005) %	91.1	91.1	91.1
	SEDBUK (2009/2012) %	89.6	89.6	89.6
	NOx classification	CLASS 6	CLASS 6	CLASS 6
	Convert to LPG	No	Yes	Yes
CONSTRUCTION	Heat exchanger material	Cast aluminium- silicon alloy		
	Burner type	Downward firing pre-mix		
	Fully modulating	Yes	Yes	Yes
	DHW plate heat exchanger	Yes	Yes	Yes
	Integrated hydroblock	Yes	Yes	Yes
INSTALLATION	Suitable for sealed systems	Yes	Yes	Yes
	Suitable for open-vent systems	No	No	No
	Filling loop	Yes	Yes	Yes
	Pre-wired mains lead	Yes	Yes	Yes
	Flow regulator	Yes	Yes	Yes
	Inbuilt system bypass	Yes	Yes	Yes
	Inbuilt condensate trap/siphon	Yes	Yes	Yes
	Inbuilt boiler frost protection	Yes	Yes	Yes
	Zero compartment ventilation	Yes	Yes	Yes
CLEARANCES	Top (min. mm) from top of boiler	165	165	165
	Side (mm)	2.5	2.5	2.5
	Bottom (mm)	100*	100*	100*
	Front (mm)	450**	450**	450**
USER INTERFACE	User display	Symbols		
	User interface	3 dials, 2 buttons		
	Diagnostics	Fault diagnosis display		
	User adjustable	Manual heating & hot water controls		
	'Eco' setting on CH	Yes	Yes	Yes
	Inbuilt programmer	Optional	Optional	Optional
PIPES	Pre-piping kit	Optional	Optional	Optional
	Stand off kit	Optional	Optional	Optional
	Stand off kit inc. pipes	Optional	Optional	Optional
	Security bracket kit	Optional	Optional	Optional
	Safety valve drain outlet pipe kit	Optional	Optional	Optional
	Terminal wall plate kit	Optional	Optional	Optional
	Weather compensation kit	Optional	Optional	Optional
FLUES	Max horizontal	9m	8m	6m
	Max vertical	7.5m	7.5m	7.5m
	Powered vertical	22m	22m	22m
	High level flue outlet kit	Optional	Optional	Optional
	Direct rear flue kit (55/80)	No	No	No
CONNECTIONS	Gas supply connection	15mm	15mm	15mm
	CH flow connection	22mm	22mm	22mm
	CH return connection	22mm	22mm	22mm
	Inlet connection - DHW	15mm	15mm	15mm
	Outlet connection - DHW	15mm	15mm	15mm
	Pressure relief valve	15mm	15mm	15mm
	Condensate drain	21.5mm	21.5mm	21.5mm
	ErP EFFICIENCIES	Condensing boiler	Yes	Yes
Seasonal space heating efficiency class		A	A	A
Rated heat output kW		24	24	24
Seasonal space heating energy efficiency η_s %		94	94	94
Sound power level, indoors LWA dB		48	46	44
Water heating energy efficiency class		A	A	A

* Can be reduced to 5mm. However, 100mm is required for servicing. ** Can be reduced to 5mm for cupboard fit, 450mm required for servicing.

LOGIC CODE COMBI ESP1

BOILER MODEL	LOGIC CODE COMBI ESP1			
	26	33	38	
SIZE	Casing dimensions (h w d)(mm)			
	Height	826	826	826
	Width	395	395	395
	Depth	278	278	278
	Weight (packed) kg	38.05	38.15	38.35
	Maximum installation weight kg	32.65	32.75	32.95
PERFORMANCE	CH output (kW) min/max mean 70°C	4.8 - 24.2	6.1 - 24.2	7.1 - 24.2
	CH output (kW) min/max mean 40°C	5.1 - 25.6	6.4 - 25.6	7.5 - 25.6
	DHW output (kW) max	26.1	32.7	38.2
	DHW flow rate l/min. 35°C rise	10.7	13.4	15.7
	SEDBUK (2005) %	91.1	91.1	91.1
	SEDBUK (2009/2012) %	89.6	89.6	89.6
	NOx classification	CLASS 6	CLASS 6	CLASS 6
	Convert to LPG	No	Yes	Yes
CONSTRUCTION	Heat exchanger material	Cast aluminium- silicon alloy		
	Burner type	Downward firing pre-mix		
	Fully modulating	Yes	Yes	Yes
	DHW plate heat exchanger	Yes	Yes	Yes
	Integrated hydroblock	Yes	Yes	Yes
INSTALLATION	Suitable for sealed systems	Yes	Yes	Yes
	Suitable for open vent systems	No	No	No
	Filling loop	Yes	Yes	Yes
	Pre-wired mains lead	Yes	Yes	Yes
	Flow regulator	Yes	Yes	Yes
	Inbuilt system bypass	Yes	Yes	Yes
	Inbuilt condensate trap/siphon	Yes	Yes	Yes
	Pump exercise	Yes	Yes	Yes
	Inbuilt boiler frost protection	Yes	Yes	Yes
	Zero compartment ventilation	Yes	Yes	Yes
	Copper tail connections	Yes	Yes	Yes
CLEARANCES	Top (min. mm) from top of boiler	165	165	165
	Side (mm)	2.5	2.5	2.5
	Bottom (mm)	100*	100*	100*
	Front (mm)	450**	450**	450**
USER INTERFACE	User display	Symbols		
	User interface	3 dials, 2 buttons		
	Diagnostics	Fault diagnostic display		
	User adjustable	Manual heating & hot water controls		
	'Eco' setting on CH	Yes	Yes	Yes
	Inbuilt programmer	Optional	Optional	Optional
PIPES	Pre-piping kit	Optional	Optional	Optional
	Stand off kit	Optional	Optional	Optional
	Stand off kit inc. pipes	Optional	Optional	Optional
	Security fixing kit	Optional	Optional	Optional
	Safety valve drain outlet pipe kit	Optional	Optional	Optional
	Terminal wall plate kit	Optional	Optional	Optional
	Weather compensation kit	Optional	Optional	Optional
FLUES	Max horizontal	9m	8m	6m
	Max vertical	7.5m	7.5m	7.5m
	Powered vertical	22m	22m	22m
	High level flue outlet kit	Optional	Optional	Optional
	Direct rear flue kit (55/80)	No	No	No
CONNECTIONS	Gas supply connection	15mm	15mm	15mm
	CH flow connection	22mm	22mm	22mm
	CH return connection	22mm	22mm	22mm
	Inlet connection - DHW	15mm	15mm	15mm
	Outlet connection - DHW	15mm	15mm	15mm
	Pressure relief valve	15mm	15mm	15mm
	Condensate drain	21.5mm	21.5mm	21.5mm
ErP EFFICIENCIES	Condensing boiler	Yes	Yes	Yes
	Seasonal space heating efficiency class	A	A	A
	Rated heat output kW	24	24	24
	Seasonal space heating energy efficiency η_s %	94	94	94
	Sound power level, indoors L _{WA} dB	49	47	44
	Water heating energy efficiency class	A	A	A

* Can be reduced to 5mm. However, 100mm is required for servicing. ** Can be reduced to 5mm for cupboard fit, 450mm required for servicing.

LOGIC HEAT

BOILER MODEL	LOGIC HEAT					
	H12	H15	H18	H24	H30	
SIZE	Casing dimensions (h w d)(mm)					
	Height	700	700	700	700	700
	Width	395	395	395	395	395
	Depth	278	278	278	278	278
	Weight (packed) kg	26.2	26.2	26.2	26.2	26.2
	Maximum installation weight kg	22.7	22.7	22.7	22.7	22.7
PERFORMANCE	CH output (kW) min/max mean 70°C	4.8 - 12.0	4.8 - 15.0	4.8 - 18.0	4.8 - 24.2	6.1 - 30.3
	CH output (kW) min/max mean 40°C	5.1 - 13.0	5.1 - 15.9	5.1 - 19.1	5.1 - 25.6	6.4 - 31.0
	DHW output (kW) max	N/A	N/A	N/A	N/A	N/A
	DHW flow rate l/min. 35°C rise	N/A	N/A	N/A	N/A	N/A
	SEDBUK (2005) %	91.1	91.2	91.1	91.2	91.1
	SEDBUK (2009/2012) %	89.4	89.4	89.7	89.7	89.6
	NOx classification	CLASS 6	CLASS 6	CLASS 6	CLASS 6	CLASS 6
	Convert to LPG	No	No	No	Yes	Yes
CONSTRUCTION	Heat exchanger material	Cast aluminium - silicon alloy				
	Burner type	Downward firing pre-mix				
	Fully modulating	Yes	Yes	Yes	Yes	Yes
	DHW plate heat exchanger	N/A	N/A	N/A	N/A	N/A
	Integrated hydroblock	N/A	N/A	N/A	N/A	N/A
INSTALLATION	Suitable for sealed systems	Yes	Yes	Yes	Yes	Yes
	Suitable for open-vent systems	Yes	Yes	Yes	Yes	Yes
	Filling loop	No	No	No	No	No
	Pre-wired mains lead	No	No	No	No	No
	Flow regulator	N/A	N/A	N/A	N/A	N/A
	Inbuilt system bypass	No	No	No	No	No
	Inbuilt condensate trap/siphon	Yes	Yes	Yes	Yes	Yes
	Inbuilt boiler frost protection	Yes	Yes	Yes	Yes	Yes
	Zero compartment ventilation	Yes	Yes	Yes	Yes	Yes
CLEARANCES	Top (mm) (from top of boiler)	165 (100 rear outlet flue)				
	Side (mm)	2.5	2.5	2.5	2.5	2.5
	Bottom (mm)	100*	100*	100*	100*	100*
	Front (mm)	450**	450**	450**	450**	450**
USER INTERFACE	User display	Symbols and simple text				
	User interface	1 dial and 2 buttons				
	Diagnostics	Fault diagnosis display				
	User adjustable	Manual heating control				
	Inbuilt programmer	No	No	No	No	No
	PIPES	Pre-piping kit	No	No	No	No
Stand off kit	Yes	Yes	Yes	Yes	Yes	
Stand off kit inc. pipes.	No	No	No	No	No	
Safety valve drain outlet pipe kit	No	No	No	No	No	
Terminal wall plate kit	Optional	Optional	Optional	Optional	Optional	
Weather compensation kit	Optional	Optional	Optional	Optional	Optional	
FLUES	Max horizontal	9m	9m	9m	9m	8m
	Max vertical	7.5m ²	7.5m ²	7.5m ²	7.5m ²	7.5m ²
	Powered vertical	22m ²	22m ²	22m ²	22m ²	22m ²
	High level flue outlet kit	Optional	Optional	Optional	Optional	Optional
Direct rear flue kit (55/80)	Yes	Yes	Yes	Yes	Yes	
CONNECTIONS*3	Gas supply connection	15mm	15mm	15mm	15mm	15mm
	CH flow connection	22mm	22mm	22mm	22mm	22mm
	CH return connection	22mm	22mm	22mm	22mm	22mm
	Inlet connection - DHW	N/A	N/A	N/A	N/A	N/A
	Outlet connection - DHW	N/A	N/A	N/A	N/A	N/A
	Pressure relief valve	N/A	N/A	N/A	N/A	N/A
	Condensate drain	21.5mm	21.5mm	21.5mm	21.5mm	21.5mm
	ErP EFFICIENCIES	Condensing boiler	Yes	Yes	Yes	Yes
Seasonal space heating efficiency class	A	A	A	A	A	
Rated heat output kW	12	15	18	24	30	
Seasonal space heating energy efficiency η_s %	93.0	93.0	93.0	94.0	93.0	
Sound power level, indoors L _{WA} dB	36	42	44	50	50	
Water heating energy efficiency class	N/A	N/A	N/A	N/A	N/A	

* Can be reduced to 5mm. However, 100mm is required for servicing. ** Can be reduced to 5mm for cupboard fit, 450mm required for servicing.

LOGIC SYSTEM

BOILER MODEL	LOGIC SYSTEM				
	S15	S18	S24	S30	
SIZE	Casing dimensions (h w d)(mm)				
	Height	700	700	700	700
	Width	395	395	395	395
	Depth	278	278	278	278
	Weight (packed) kg	31.5	31.5	31.5	31.5
	Maximum installation weight kg	26.1	26.1	26.1	26.1
PERFORMANCE	CH output (kW) min/max mean 70°C	4.8 - 15.0	4.8 - 18.0	4.8 - 24.2	6.1 - 30.3
	CH output (kW) min/max mean 40°C	5.1 - 15.9	5.1 - 19.1	5.1 - 25.6	6.4 - 31.0
	DHW output (kW) max	N/A	N/A	N/A	N/A
	DHW flow rate l/min. 35°C rise	N/A	N/A	N/A	N/A
	SEDBUK (2005) %	91.2	91.1	91.2	91.1
	SEDBUK (2009/2012) %	89.4	89.7	89.7	89.6
	NOx classification	CLASS 6	CLASS 6	CLASS 6	CLASS 6
	Convert to LPG	No	No	No	Yes
CONSTRUCTION	Heat exchanger material	Cast aluminium - silicon alloy			
	Burner type	Downward firing pre-mix			
	Fully modulating	Yes	Yes	Yes	Yes
	DHW plate heat exchanger	N/A	N/A	N/A	N/A
	Integrated hydroblock	N/A	N/A	N/A	N/A
INSTALLATION	Suitable for sealed systems	Yes	Yes	Yes	Yes
	Suitable for open-vent systems	No	No	No	No
	Filling loop	No	No	No	No
	Pre-wired mains lead	Yes	Yes	Yes	Yes
	Flow regulator	N/A	N/A	N/A	N/A
	Inbuilt system bypass	Yes	Yes	Yes	Yes
	Inbuilt condensate trap/siphon	Yes	Yes	Yes	Yes
	Inbuilt boiler frost protection	Yes	Yes	Yes	Yes
CLEARANCES	Zero compartment ventilation	Yes	Yes	Yes	Yes
	Top (mm) (from top of boiler)	165	165	165	165
	Side (mm)	2.5	2.5	2.5	2.5
	Bottom (mm)	100*	100*	100*	100*
USER INTERFACE	Front (mm)	450**	450**	450**	450**
	User display	Symbols and simple text			
	User interface	1 dial and 2 buttons			
	Diagnostics	Fault diagnosis display			
	User adjustable	Manual heating control			
	Inbuilt programmer	No	No	No	No
PIPES	Pre-piping kit	Yes	Yes	Yes	Yes
	Stand off kit	Yes	Yes	Yes	Yes
	Stand off kit inc. pipes.	Yes	Yes	Yes	Yes
	Safety valve drain outlet pipe kit	Optional	Optional	Optional	Optional
	Terminal wall plate kit	Optional	Optional	Optional	Optional
	Weather compensation kit	Optional	Optional	Optional	Optional
FLUES	Max horizontal	9m	9m	9m	8m
	Max vertical	7.5m	7.5m	7.5m	7.5m
	Powered vertical	22m	22m	22m	22m
	High level flue outlet kit	Optional	Optional	Optional	Optional
	Direct rear flue kit (55/80)	No	No	No	No
CONNECTIONS*2	Gas supply connection	15mm	15mm	15mm	15mm
	CH flow connection	22mm	22mm	22mm	22mm
	CH return connection	22mm	22mm	22mm	22mm
	Inlet connection - DHW	N/A	N/A	N/A	N/A
	Outlet connection - DHW	N/A	N/A	N/A	N/A
	Pressure relief valve	N/A	N/A	N/A	N/A
	Condensate drain	21.5mm	21.5mm	21.5mm	21.5mm
ErP EFFICIENCIES	Condensing boiler	Yes	Yes	Yes	Yes
	Seasonal space heating efficiency class	A	A	A	A
	Rated heat output kW	15	18	24	30
	Seasonal space heating energy efficiency η_s %	93	93	94	93
	Sound power level, indoors LWA dB	42	44	50	50
	Water heating energy efficiency class	N/A	N/A	N/A	N/A

* Can be reduced to 5mm. However, 100mm is required for servicing. ** Can be reduced to 5mm for cupboard fit, 450mm required for servicing.

IDEAL THERMSTORE INDIRECT CYLINDER



Scan me for full technical specification

CYLINDER 90 120 150 180 210 250 300 400 kW

90 - IDEPLUIN090 | 120 - IDEPLUIN120 | 150 - IDEPLUIN150 | 180 - IDEPLUIN180 | 210 - IDEPLUIN210
250 - IDEPLUIN250 | 300 - IDEPLUIN300 | 400 - IDEPLUIN400

The Ideal Thermstore range of stainless steel unvented indirect cylinders are manufactured to the highest standards. The range features 8 models and 2 years parts and labour warranty so you can be sure the Thermstore combines the twin demands of excellent product quality and outstanding value.

STANDARD APPLIANCE

- > Hot water draw off 22mm compression
- > Temperature and pressure relief valve 92-9°C/6 bar
- > Hot water secondary return 22mm (not fitted to cylinders below 210 litres)
- > Immersion heater 1¾" BSP 3kW
- > Cold supply 22mm compression
- > Dual control/overheat thermostat pocket
- > Boiler control sensor pocket (spare)
- > Primary flow 22mm compression (28mm tails for 400 litre model only)
- > Primary return 22mm compression (28mm tails for 400 litre model only)

STANDARD APPLIANCE COMPONENTS

- > Combination inlet group incorporating pressure reducing valve, strainer, check valve, balanced cold take off point, expansion relief valve and expansion vessel connection points
- > Potable expansion vessels complete with flexible hose and wall bracket
- > Tundish
- > Dual control thermostat and combined overheat thermostat
- > Two port 22mm zone valve for primary circuit
- > Wiring junction box for primary system



IDEAL THERMSTORE PRE PLUMBED S



Scan me for
full technical
specification

CYLINDER 120 150 180 210 250 300 kW

120 - IDEPROIN120PPSP | 150 - IDEPROIN150PPSP | 180 - IDEPROIN180PPSP | 210 - IDEPROIN210PPSP
250 - IDEPROIN250PPSP | 300 - IDEPROIN300PPSP

Our range of pre-plumbed cylinders have been created specifically for the new build market. They offer a 'plug and play' solution which reduces installation time and standardises plumbing configuration across multiple dwelling sites. It offers a 2 year parts warranty and 25 year vessel warranty.

STANDARD APPLIANCE

- > Hot water draw off (22mm), including elbow
- > 22mm cold supply
- > Combination inlet group incorporating pressure reducing valve, strainer, check valve, balance cold take off point, expansion relief valve and expansion vessel connection points.
- > Pressure and temperature relief valve 89 - 96°C/6 bar
- > Connection for heating expansion relief valve
- > Tundish
- > Hot water secondary return 22mm
- > Cold feed assembly
- > Immersion heater 1 3/4" BSP 3kW
- > Wiring junction box
- > Manifold assembly
- > Central heating zone 1 (22mm)
- > Central heating zone 2 (22mm)
- > Boiler flow (28mm)
- > Dual control/overheat stat (22mm)
- > Drain valve
- > Connection for heating expansion vessel
- > Central heating return (22mm)
- > Boiler return (28mm)
- > Filling loop
- > Manual air vent
- > Hot water zone valve
- > System pressure operated bypass
- > Balancing valve

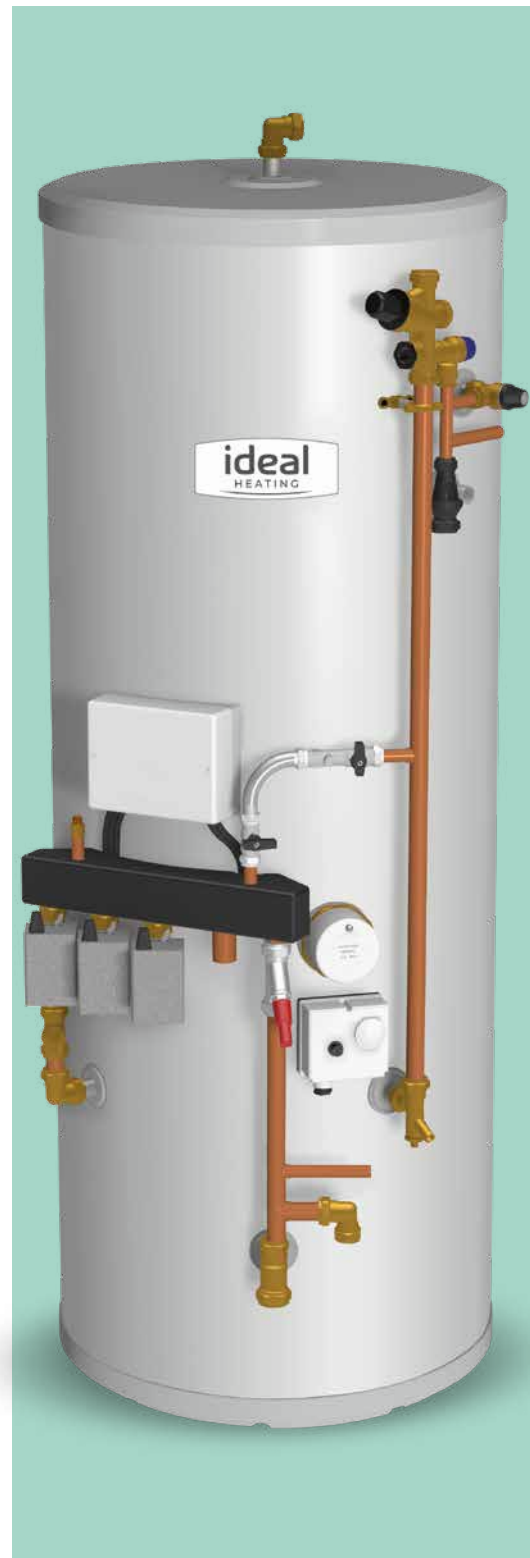

IDEAL THERMSTORE PRE PLUMBED H



Scan me for
full technical
specification

CYLINDER 120 150 180 210 250 300 kW

120 - IDEPROIN120PP | 150 - IDEPROIN150PP | 180 - IDEPROIN180PP | 210 - IDEPROIN210PP
250 - IDEPROIN250PP | 300 - IDEPROIN300PP

Our range of pre-plumbed cylinders have been created specifically for the new build market. They offer a 'plug and play' solution which reduces installation time and standardises plumbing configuration across multiple dwelling sites.

STANDARD APPLIANCE

- > Hot water draw off (22mm), including elbow
- > 22mm cold supply
- > Combination inlet group incorporating pressure reducing valve, strainer, check valve, balance cold take off point, expansion relief valve and expansion vessel connection points.
- > Pressure and temperature relief valve 89 - 96°C/6 bar
- > Connection for heating expansion relief valve
- > Tundish
- > Hot water secondary return 22mm
- > Cold feed assembly
- > Immersion heater 13/4" BSP 3kW
- > Wiring junction box
- > Manifold assembly
- > Central heating zone 1 (22mm)
- > Central heating zone 2 (22mm)
- > Boiler flow (28mm)
- > Dual control/overheat stat (22mm)
- > Drain valve
- > Connection for heating expansion vessel
- > Central heating return (28mm)
- > Boiler return
- > Filling loop
- > Manual air vent
- > Hot water zone valve
- > System pressure operated bypass
- > Balancing valve
- > Low energy consumption circulation pump





POD INDIRECT

HIU i305 i405 i505 i605 i705



Scan me for
full technical
specification

Available in outputs of 30, 40, 50, 60 and 70kW, the indirect POD HIU is designed to meet all the requirements of the heat network installer, operator and end user. Also available as direct appliances.

**2 YEARS
WARRANTY***

KEY FEATURES

- ✓ Two years warranty as standard
- ✓ Internal insulation
- ✓ Simple user interface
- ✓ First Fix Kit (supplied separately)
- ✓ Removable Front Cover
- ✓ Drop-down front panel
- ✓ Heat Metering (optional)
- ✓ Advanced control features, simple to use interface



**FIRST FIX KIT
AVAILABLE**

POD DIRECT

HIU D30 D40 D50 D60



Scan me for full technical specification

Available in outputs of 30, 40, 50 & 60kW, the direct POD HIU is designed to meet all the requirements of the heat network installer, operator and end user. Also available as indirect appliances.

2 YEARS WARRANTY*

KEY FEATURES

- ✓ Two years warranty as standard
- ✓ Internal insulation
- ✓ Simple user interface
- ✓ First Fix Kit (supplied separately)
- ✓ Removable Front Cover
- ✓ Drop-down front panel
- ✓ Heat Metering (optional)
- ✓ Advanced control features, simple to use interface



FIRST FIX KIT AVAILABLE

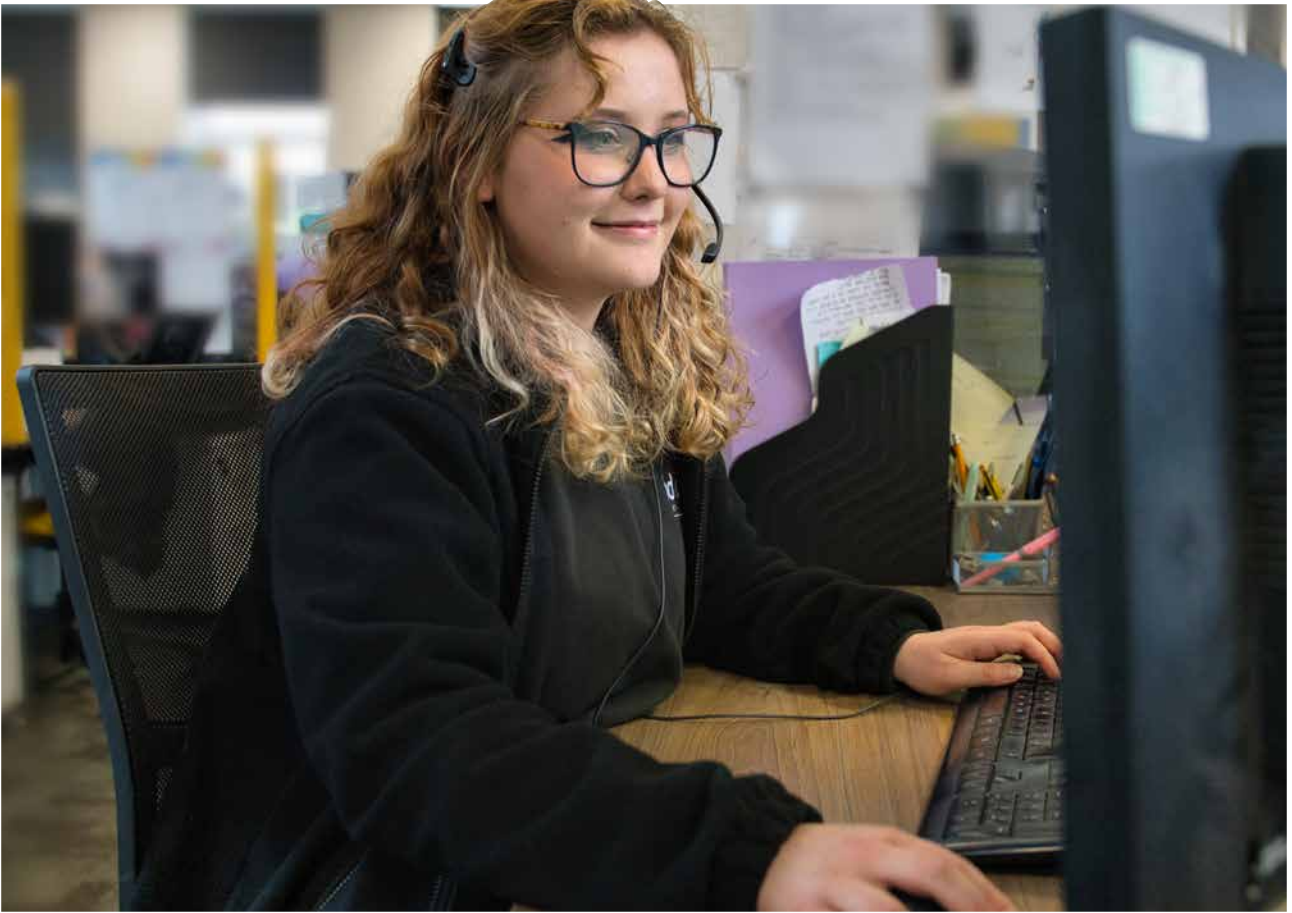

INDUSTRY LEADING CUSTOMER SERVICE



EXPERTS TOGETHER

We are committed to delivering the highest level of customer service. Experts together with over 140 years experience of heating and hot water, we know how important confidence and trust are to our customers.



364 DAYS A YEAR

We are is on hand to ensure you have the support you need. Our dedicated customer service department is available 364 days a year.



TEAM OF EXPERTS

We also have a team of expert engineers, fully trained to exacting standards and Gas Safe registered, on hand to provide one-to-one advice on the road, over the phone or online ensuring you're fully supported, wherever and whenever you need.

DEVELOPER CONNECT

Developer Connect is the online portal from Ideal Heating that enables you to manage your boiler and heat pump warranties and gas safe registrations from one online portal.

- > One online portal to keep track of all boiler and heat pump registrations.
- > Register your boiler for a FREE building regulations compliance with Gas Safe Register through your account.
- > Once set up you will have access to your previous boiler and heat pump registration details to hand whenever you need them.
- > Industry leading customer service to support you when you needs us.



IDEAL DESIGN SERVICE

idealheating.com/new-build/design-service

As part of our design service, our in-house design team will find the right products for your development, design your heating system to achieve the necessary SAP ratings and finally deliver this to you as a fully detailed system plan.

STEP 1

You raise an enquiry with us and complete our handy developer checklist. Download your checklist on our website or email design.enquiries@idealheating.com

STEP 2

Simply send the completed form to design.enquiries@idealheating.com, along with plans, sections and elevations in the formats listed, and any other additional information mentioned in the checklist.

STEP 3

We aim to respond to new enquiries within 20 working days. If you have a specific deadline in mind, please contact the Design Office at design.enquiries@idealheating.com

STEP 4

When your designs are completed, we'll send them to you in PDF or DWG format.

STEP 5

Our internal system is updated and records kept on file, just in case any revisions are required.



Partnered with Ideal our independent SAP Solution consultants Briary Energy can offer you a complete value-engineered solution to meet Building Regulations Compliance.

Our aim is to give you the most cost effective solution for your build, including building fabric, U-value calculations, thermal bridging, ventilation, heating and renewables.

As part of the Ideal Package, we will keep you up to date with the latest legislation helping you keep ahead of the game. We can even promise any question will be answered within 24 hours.

FIRST CLASS INDUSTRY TRAINING

IN-PERSON

Work face-to-face with our Experts in Heating.

Work on our leading range of products in-person with training delivered from your premises.

LIVE VIRTUAL

Always live, presented by our Experts in Heating.

Our live virtual training allows you to complete quality training online, without the travel time and costs. We use a fully equipped filming studio to provide high definition and detailed views. You can ask questions to our Experts throughout.

ON-DEMAND 24/7

What you need, when and where you need it!

Request a personal training account to access our comprehensive range of training products available to access 24/7. Designed to help you learn when suits you as well as providing on the job support.



BOILER FLUE SITTING

There are a substantial number of flue options available with the Ideal ranges, giving excellent siting flexibility for almost all applications. The range of options include standard and telescopic flues as well as roof flue and powered vertical flue options. To ensure siting issues are kept to a minimum, High Level Flue Outlet kit options and Flue Deflector kits are available.

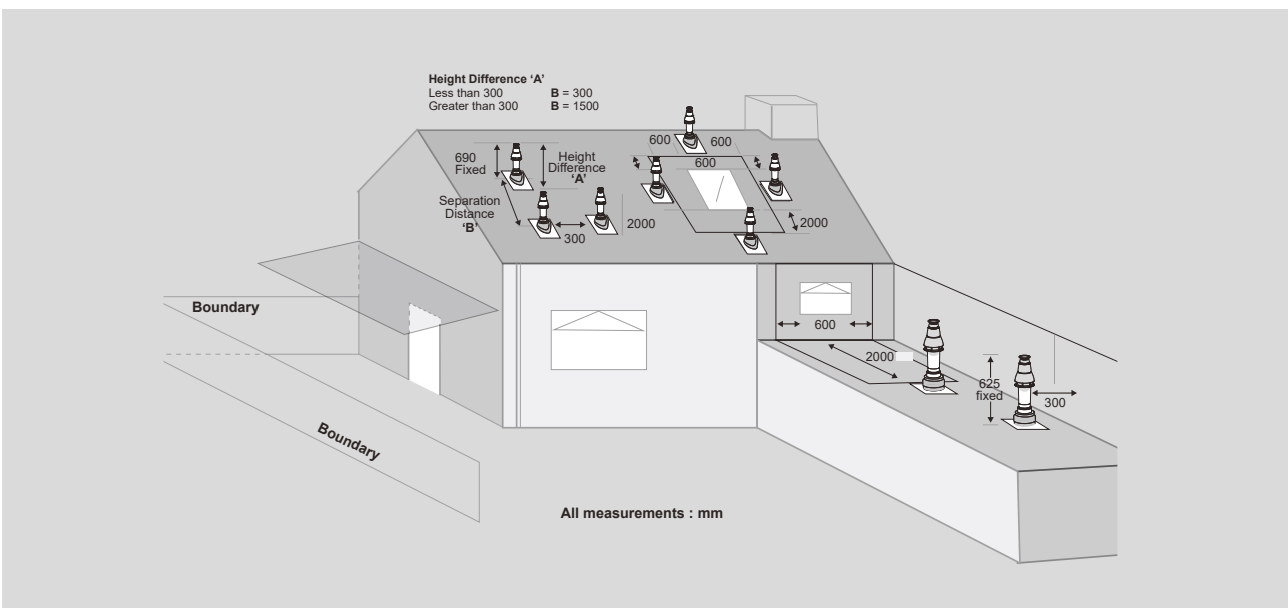
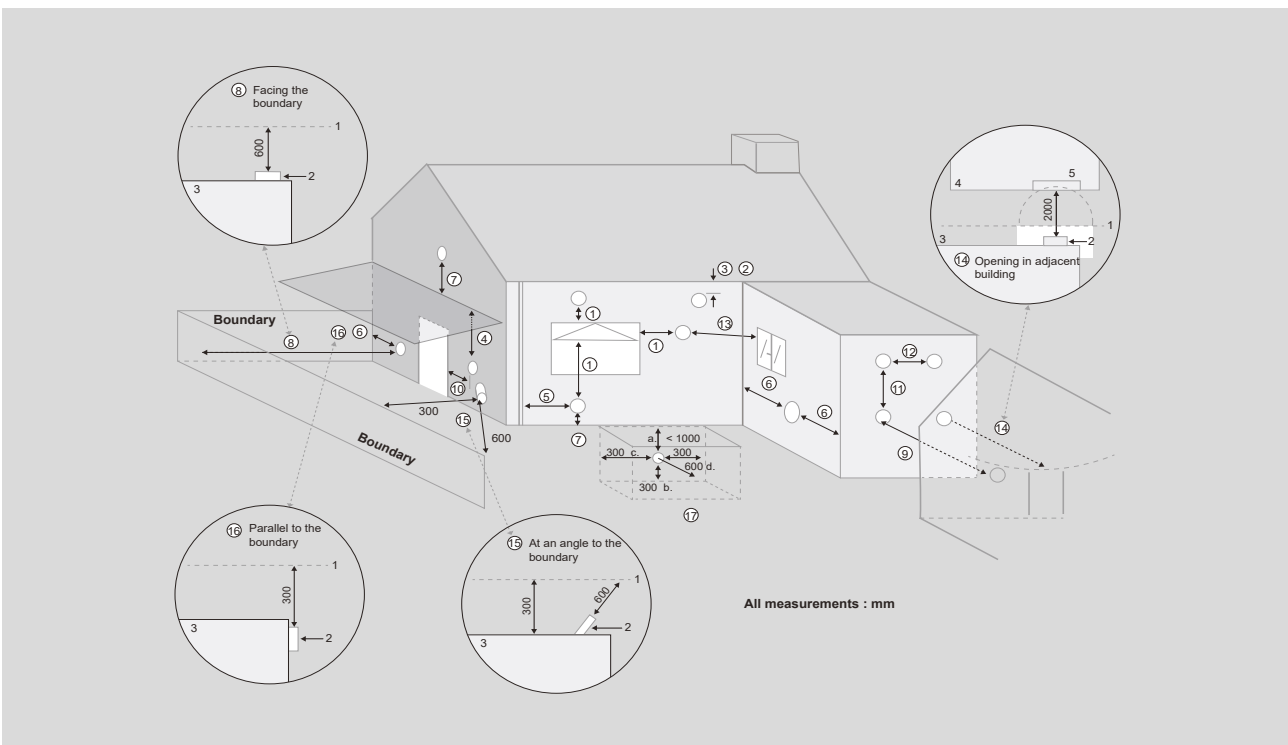

FLUE TERMINAL POSITION	MIN. SPACING
1. Directly below, above or alongside an opening. 300 mm	300mm
2. Below guttering, drain pipes or soil pipes.	75mm 25mm*
3. Below eaves.	200mm 25mm*
4. Below balconies or car port roof.	200mm 25mm*
5. From vertical drain pipes or soil pipes.	150mm 25mm*
6. From an internal or external corner or to a boundary alongside the terminal.	300mm 25mm*
7. Above ground, roof or balcony level.	300mm
8. From a surface or a boundary facing a terminal.	600mm
9. From a terminal facing a terminal.	1200mm
10. From an opening in a car port into dwelling.	1200mm
11. Vertically from a terminal on the same wall.	1500mm
12. Horizontally from a terminal wall.	300mm
13. Horizontally from an adjacent window	600mm
14. Facing an opening into an adjacent building	2000mm
15. At an angle to the boundary	300mm 600mm
16. Parallel to a boundary	300mm
17. Below ground level - open light well a) Below ground b) Above floor level c) From side d) From facing surface	<1,000 mm 300mm 300mm 600mm

FLUE ACCESSORIES

When Building Regulations direct that combustible materials must not be used in the external walls of high-rise residential buildings, our high rise flues with an inner aluminium flue duct should be used.

Horizontal flue non-telescopic 0.6m (181-556mm)



Ideal part no. 208171

Horizontal flue non-telescopic 0.8m (601-816mm)



Ideal part no. 217442

Horizontal flue telescopic 0.5m (286-484mm)



Ideal part no. 208169

Horizontal flue telescopic 0.7m (526-741mm)



Ideal part no. 208174

Horizontal flue rear outlet Heat (Ø55/80mm)

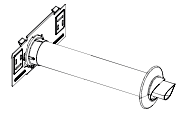

Ideal part no. 205990

Flue extension with bracket 0.5m, 1m or 2m

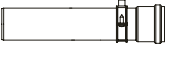

Ideal part no. 0.5m 211037
1m 203129
2m 211038

Raised horizontal flue kit

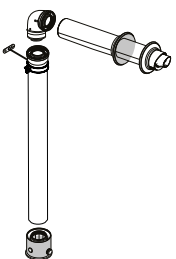

NOTE:
A 1 metre vertical pipe is supplied as standard. Both horizontal and vertical lengths can be extended.

Ideal part no. 208290

Balcony flue kit

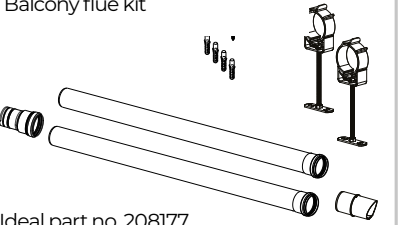

Ideal part no. 208177

Soffit flue kit

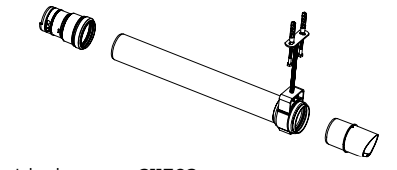

Ideal part no. 211302

Flue bend 90°



Ideal part no. 203130

Flue bend 45° pair

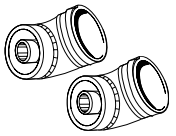

Ideal part no. 203131

Flue deflector (Ø 60mm)

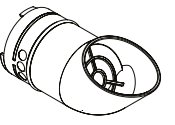

Ideal part no. 208176

Vertical flue terminal and connector (Ø60/100mm)



Ideal part no. 211039

Vertical flue terminal (Ø60/100mm)

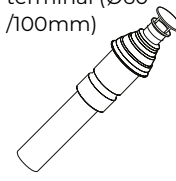

Ideal part no. 203132

Vertical flue connector (Ø60/100mm)

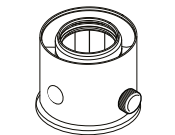

Ideal part no. 208175

Vertical flue terminal extension (Ø60/100mm)

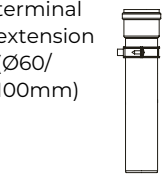

Ideal part no. 210803

Vertical flue loft air inlet (Ø80mm outlet)



Ideal part no. 203136

Flue extension 1m pair (Ø80mm)

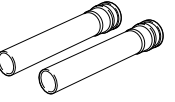

Ideal part no. 203142

Vertical flue terminal (Ø80mm connection)

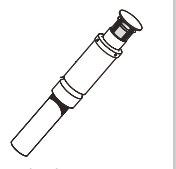

Ideal part no. 203134

Weather collar pitched roof

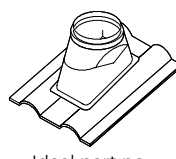

Ideal part no. 152258

Weather collar flat roof

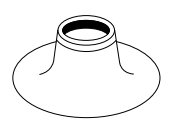

Ideal part no. 152259

High level flue outlet kit (Ø60mm)



Ideal part no. 208178

Flue extension 1m for high level flue outlet (Ø60mm)

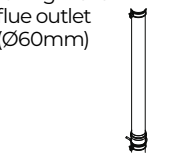

Ideal part no. 203228

High level flue bend 90° (Ø60mm)

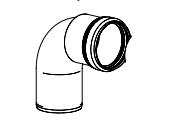

Ideal part no. 90° 203229
45° 203230

High level flue outlet kit for Heat rear outlet

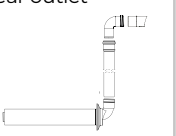

Ideal part no. 205989

Adjustable flue bracket



Ideal part no. Ø100 205247
Ø80 205028

Flue finishing kit (Ø100/80mm)

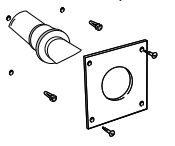

Ideal part no. Ø100 155988
Ø80 206151

RS terminal replacement wall plate

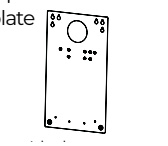

Ideal part no. System 211328
Combi 206164

Flue securing screws



Ideal part no. 205024

Timber frame wall tube 0.4m

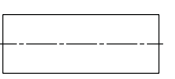

Ideal part no. 229130

Timber frame wall plates

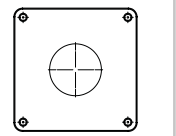

Ideal part no. 229128

INSTALLATION ACCESSORIES

STAND OFF KIT

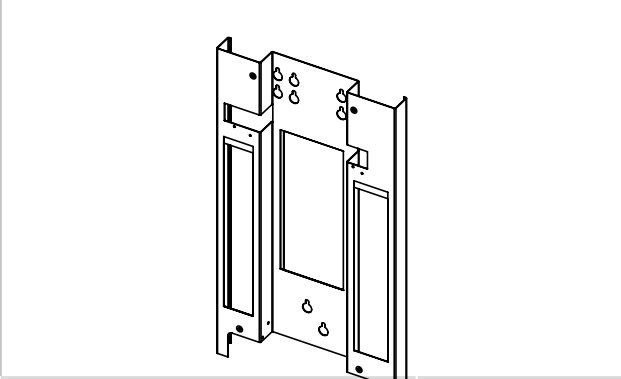

INSTALLATION ACCESSORY	PART NO.
Stand-off kit Combi ² and System ²	229120
Stand-off kit Heat ²	206153
Stand-off kit Logic Combi ESP1	211103
Stand-off kit Logic Code Combi ESP1	211335

STAND OFF KIT WITH PIPES

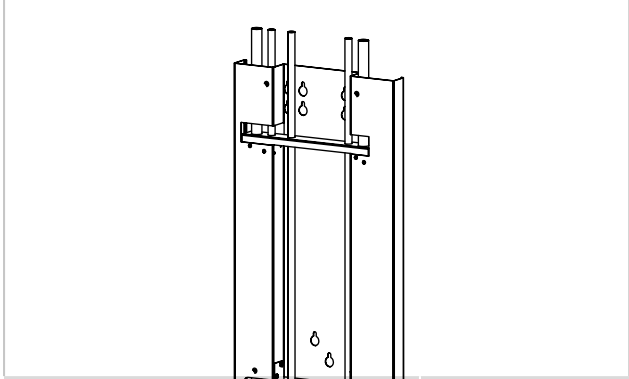

INSTALLATION ACCESSORY	PART NO.
Stand-off kit with pipes Combi ²	227769
Stand-off kit with pipes System ²	227770
Stand-off kit with pipes Logic Combi ESP1	211101
Stand-off kit with pipes Logic Code Combi ESP1	211333

SECONDARY PRESSURE RELIEF VALVE KIT

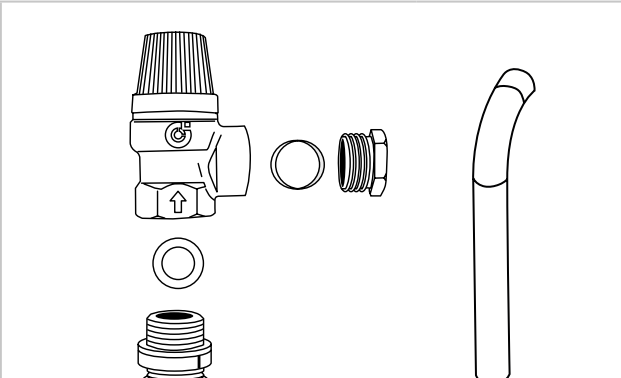

INSTALLATION ACCESSORY	PART NO.
Secondary pressure relief valve	234642

PRV OUTLET PIPE

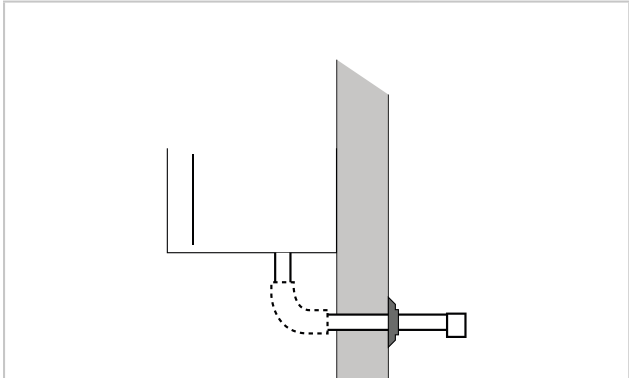

INSTALLATION ACCESSORY	PART NO.
PRV outlet pipe	205126

INSTALLATION ACCESSORIES

Our range of installation accessories are widely available due to our excellent distribution network. Our installation accessories include a range of brackets and stand off kits as well as a range of kits to help you deal with any situation.

STAND OFF KIT

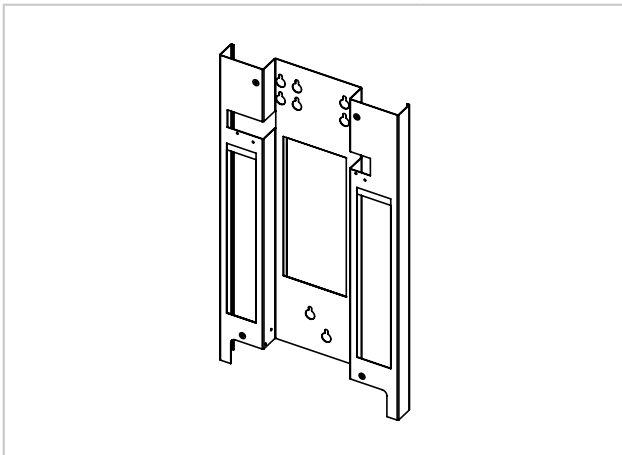

INSTALLATION ACCESSORY	PART NO.
Stand-off kit Combi ² and System ²	229120
Stand-off kit Heat ²	206153
Stand-off kit Logic Combi ESP1	211103
Stand-off kit Logic Code Combi ESP1	211335

STAND OFF KIT WITH PIPES

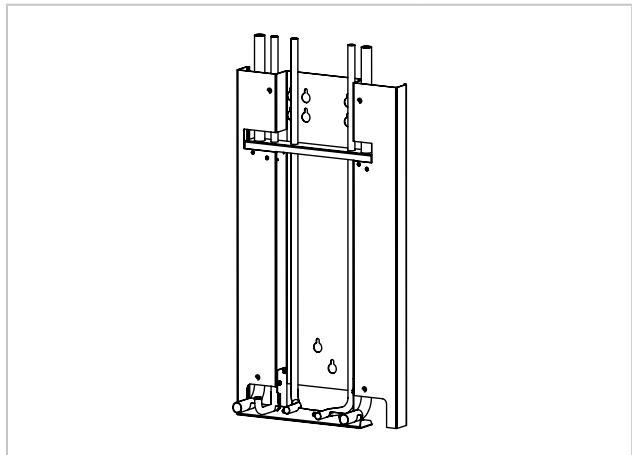

INSTALLATION ACCESSORY	PART NO.
Stand-off kit with pipes Combi ²	227769
Stand-off kit with pipes System ²	227770
Stand-off kit with pipes Logic Combi ESP1	211101
Stand-off kit with pipes Logic Code Combi ESP1	211333

SECONDARY PRESSURE RELIEF VALVE KIT

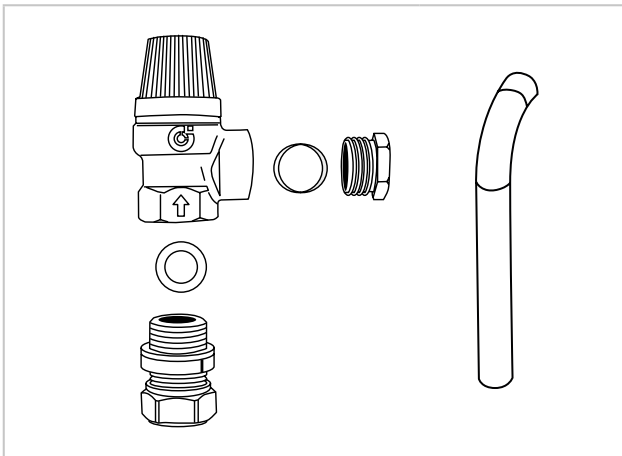

INSTALLATION ACCESSORY	PART NO.
Secondary pressure relief valve	234642

PRV OUTLET PIPE

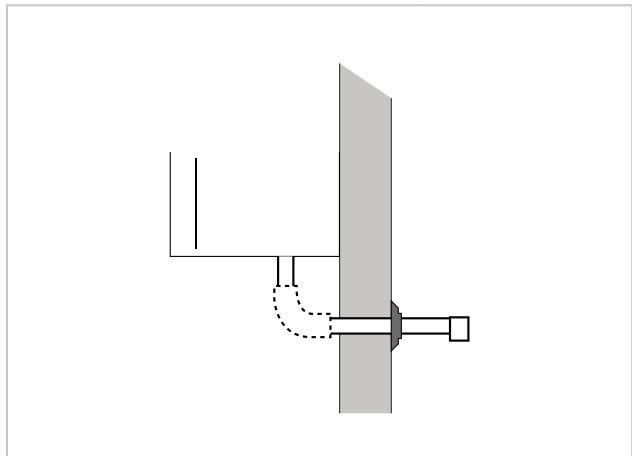

INSTALLATION ACCESSORY	PART NO.
PRV outlet pipe	205126

DHW EXPANSION VESSEL KIT

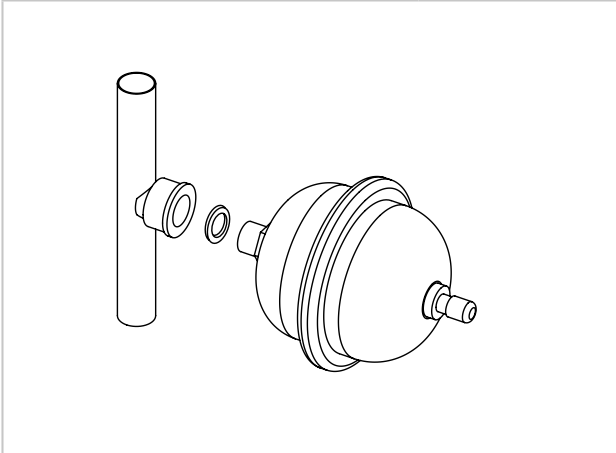

INSTALLATION ACCESSORY	PART NO.
DHW expansion vessel	205419

IDEAL SYSTEM FILTER

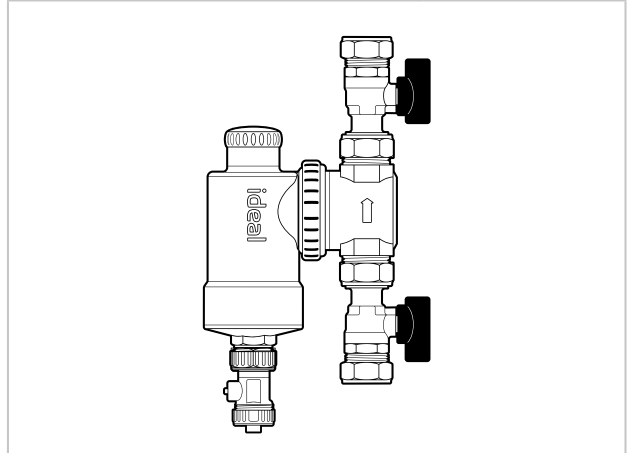

INSTALLATION ACCESSORY	PART NO.
Ideal system filter	236531
Flushing adaptor for system filter	237010
Camlock Magnaclone adaptors	237516

CONDENSATE PUMP KIT

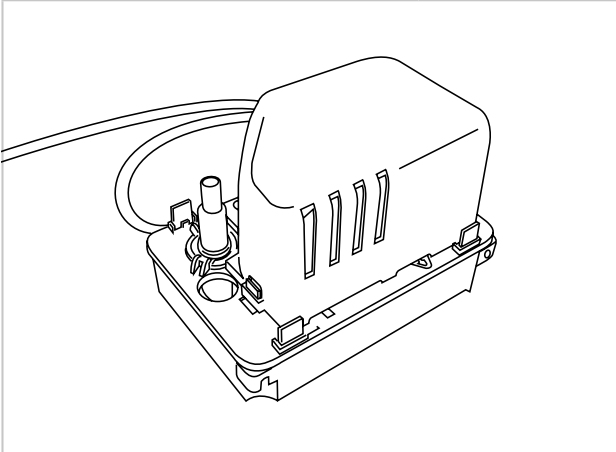

INSTALLATION ACCESSORY	PART NO.
Condensate pump kit	159991

THE UK'S **NUMBER ONE** HOT WATER CYLINDER MANUFACTURER



Gledhill is leading UK manufacturer of hot water and heating solutions. Established in 1926, quality, innovation and reliability are at the heart of our business.

With over 90 years of experience manufacturing domestic hot water cylinders, Gledhill has become the UK's Number One Cylinder manufacture in every hot water cylinder solution including Directs, Indirect, Pre-Plumbed and Slimline, Heat Pump & Solar cylinders off a complete renewable cylinder range.

STAINLESS PLATINUM PRE-PLUMBED DIRECT

CYLINDER 120 150 180 210 290 LITRES

120 - PLTDRI20PP | 150 - PLTDRI50PP | 180 - PLTDRI80PP | 210 - PLTDR210PP | 290 - PLTDR290PP

The internal expansion hot water cylinder.

25 YEARS WARRANTY

KEY FEATURES

- ✓ Pre-plumbed configuration for quicker and easier installation process
- ✓ Built-in internal expansion removing the requirement for an expansion vessel to be fitted externally
- ✓ Specially configured pre-plumbed pipework incorporating a blending valve to maximise the hot water capacity
- ✓ Anti-vacuum valve supplied



Scan me for full technical specification



STAINLESS PLATINUM PRE-PLUMBED INDIRECT

CYLINDER 120 150 180 210 250 300 LITRES

The internal expansion hot water cylinder.

25 YEARS WARRANTY

KEY FEATURES

- ✓ Pre-plumbed configuration for quicker and easier installation process
- ✓ Built-in internal expansion removing the requirement for an expansion being fitted externally
- ✓ Pre-Plumbed indirect manifold configuration comes complete with two heating zones and pump
- ✓ System Plus Indirect manifold configuration comes complete with two heating zones
- ✓ System Ready Indirect manifold configuration comes complete with one heating zone



Scan me for full technical specification



STAINLESS PLATINUM DIRECT

CYLINDER 120 150 180 210 LITRES

120 - PLTDR120 | 150 - PLTDR150 | 180 - PLTDR180 | 210 - PLTDR210

The internal expansion hot water cylinder.

**25 YEARS
WARRANTY**

KEY FEATURES

- ✓ Designed for use with electricity either from mains supply or photovoltaic panels
- ✓ Suitable for use with economy electricity tariffs to maximise efficiency
- ✓ 3kW incoloy 825 immersion heater for use as a primary heat source
- ✓ 3kW incoloy 825 immersion heater for emergency back-up
- ✓ 90° elbow and drain valve supplied as standard



Scan me for full technical specification

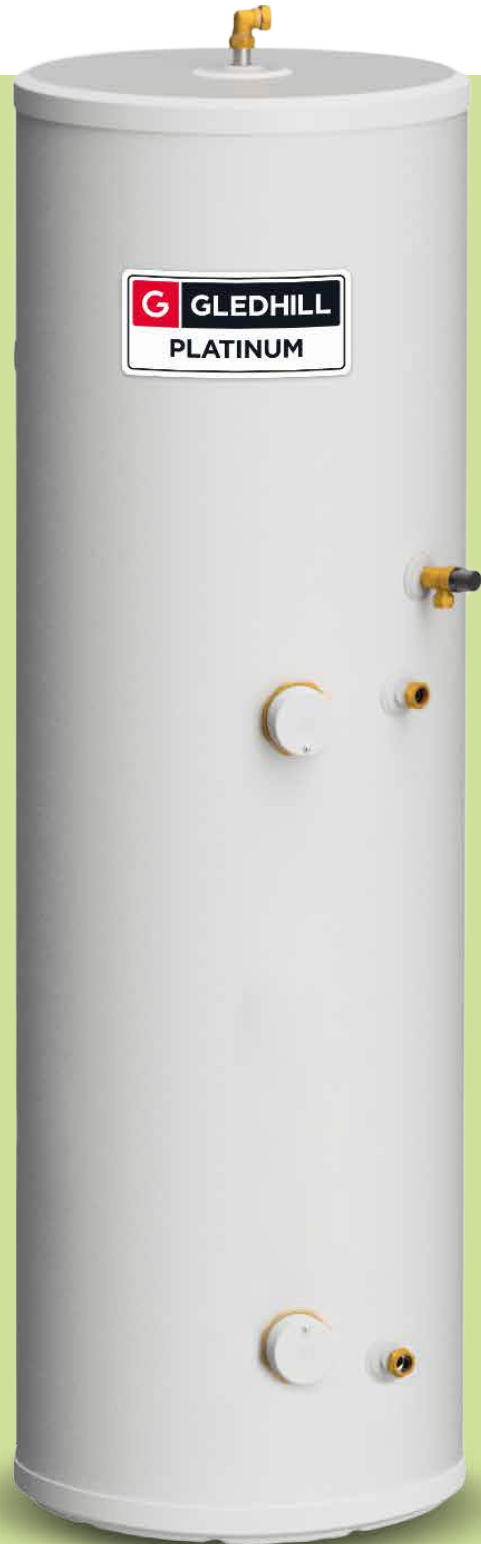

STAINLESS PLATINUM INDIRECT

CYLINDER 120 150 180 210 250 300 LITRES

120 - PLTIN120 | 150 - PLTIN150 | 180 - PLTIN180 | 210 - PLTIN210 | 250 - PLTIN250 | 300 - PLTIN300

The internal expansion hot water cylinder.

**25 YEARS
WARRANTY**

KEY FEATURES

- ✓ Designed for use with gas or oil boilers, either sealed system or open vented
- ✓ High efficiency corrugated coil maximises heat transfer to the cylinder of water
- ✓ Corrugated coil provides faster reheat times compared to plain coil
- ✓ 3kW incoloy immersion heater for emergency back-up
- ✓ 90° elbow and drain valve supplied as standard



Scan me for full technical specification



STAINLESSLITE PRE-PLUMBED INDIRECT

CYLINDER 120 150 180 210 250 300 LITRES

Partially and Fully Pre-Plumbed

120 - PROIN120PP | 150 - PROIN150PP | 180 - PROIN180PP | 210 - PROIN210PP | 250 - PROIN250PP | 300 - PROIN300PP

Designed to be fitted with a heat only boiler.

25 YEARS WARRANTY

KEY FEATURES

- ✓ Designed with flat top to increase insulation
- ✓ Wide base to improve unit stability
- ✓ Quality components ensure a reliable, durable product
- ✓ 90° elbow and drain valve supplied as standard
- ✓ Developed for new build
- ✓ Lightest cylinder on the market
- ✓ Optional room thermostats available at time of order, with one and two channels, to allow for two heating zones



Scan me for full technical specification

STAINLESSLITE SYSTEM PLUS INDIRECT

CYLINDER 120 150 180 210 250 300 LITRES

Partially and Fully Pre-Plumbed

120 - PROIN120PPSP | 150 - PROIN150PPSP | 180 - PROIN180PPSP | 210 - PROIN210PPSP | 250 - PROIN250PPSP | 300 - PROIN300PPSP

Designed to be fitted with system boilers.

25 YEARS WARRANTY

KEY FEATURES

- ✓ Designed with flat top to increase insulation
- ✓ Wide base to improve unit stability
- ✓ Quality components ensure a reliable, durable product
- ✓ 90° elbow and drain valve supplied as standard
- ✓ Developed for new build
- ✓ Lightest cylinder on the market
- ✓ Optional room thermostats available at time of order, with one and two channels, to allow for two heating zones

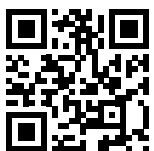

Scan me for full technical specification



STAINLESSLITE SYSTEM READY INDIRECT

CYLINDER 120 150 180 210 250 300 LITRES

Partially and Fully Pre-Plumbed

120 - PROIN120PPSR | 150 - PROIN150PPSR | 180 - PROIN180PPSR | 210 - PROIN210PPSR | 250 - PROIN250PPSR | 300 - PROIN300PPSR

Designed to be fitted with
system boilers.

**25 YEARS
WARRANTY**

KEY FEATURES

- ✓ Designed with flat top to increase insulation
- ✓ Wide base to improve unit stability
- ✓ Quality components ensure a reliable, durable product
- ✓ 90° elbow and drain valve supplied as standard
- ✓ Developed for new build
- ✓ Lightest cylinder on the market
- ✓ Optional room thermostats available at time of order, with one and two channels, to allow for two heating zones



Scan me for
full technical
specification

GLEDHILL CYLINDER WASHING MACHINE FRAME

COMPATIBLE WITH CYLINDERS BETWEEN 120 - 250 LITRES

Product Code: MS600

The Gledhill washing machine frame perfectly accommodates all of our Platinum Direct cylinder sizes as well as over 50% of our Platinum Indirect cylinders. In addition, our washing machine frame is suitable for nearly all our Stainlesslite Plus 120L - 250L hot water cylinders as well as our Stainless ES and Gledhill Stainless Pro cylinders between 120L and 250L in size.

Designed with space saving efficiency in mind for new build homes as well as apartments our washing machine frame comes flat packed and when built up has a height of 910mm, width of 670mm and depth of 600mm making it the perfect solution for any space restriction issue.

KEY FEATURES

- ✓ Engineered from stainless steel for stability
- ✓ Accommodates 120L - 250L cylinder sizes
- ✓ Arrives flat packed and built in minutes
- ✓ Solution for space restrictions in new builds and apartment complexes
- ✓ Designed for all cylinders ranges including Platinum



Scan me for
full technical
specification

TOTAL ELECTRIC SOLUTIONS.

atlantic

With over 50 years of experience in designing, engineering, and manufacturing electric heating and hot water appliances the Atlantic brand has become synonymous with premium, high efficiency products.

Atlantic has engineered and developed an extensive product range that includes panel heaters, electric radiators, towel rails and hot water cylinders. Our innovative, reliable and energy efficient product portfolio offers the perfect electric heating solutions for new builds, bungalows, flats, apartments, hotels, offices and commercial establishments.

SOKIO HORIZONTAL



Scan me for full technical specification

PANEL HEATER

The Sokio electric panel heater combines clean, asymmetric styling with aluminium plate technology, offering you soft, homogeneous heat.

Equipped with an LCD digital control panel and a high-precision electric thermostat, along with a programmable mode provides the user with full control and flexibility over their home heating.

KEY FEATURES

- ✓ ErP lot 20
- ✓ Anti frost mode
- ✓ Double heating elements
- ✓ Aluminium heating element
- ✓ Open/closed window detection
- ✓ High precision electric thermostat

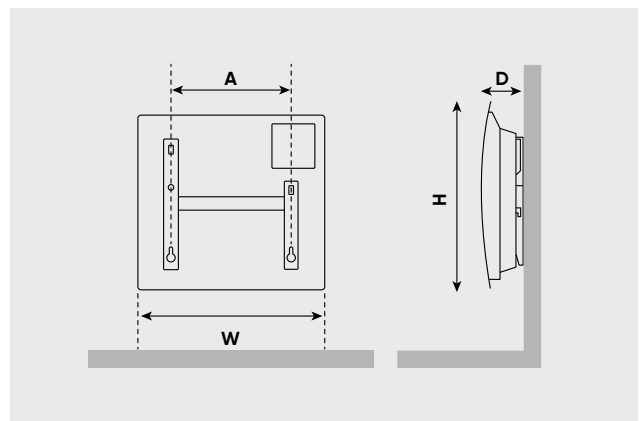

LCD DIGITAL CONTROL PANEL

OUTPUT (W)	DEPTH (MM)	WIDTH (MM)	HEIGHT (MM)	A (MM)	WEIGHT (KG)	MODEL
750	130	601	477	343	8.3	AH503108
1000	130	601	477	343	8.3	AH503109
1250	130	823	477	565	10.1	AH503111
1500	130	823	477	565	10.1	AH503113
2000	130	1045	477	787	13.1	AH503114

SOKIO VERTICAL

PANEL HEATER



Scan me for full technical specification

Designed with an aluminum plate face offering even heat distribution to quickly heat up the room. The Sokio Vertical combines clean, asymmetric styling with a simplistic design to work perfectly in any modern home or establishment.

KEY FEATURES

- ✓ ErP lot 20
- ✓ Anti frost mode
- ✓ Double heating elements
- ✓ Aluminium heating element
- ✓ Lcd digital control panel
- ✓ High precision electric thermostat

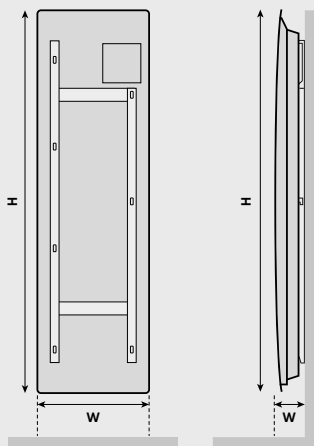

OPEN/CLOSED
WINDOW
DETECTION

OUTPUT (W)	WIDTH (MM)	HEIGHT (MM)	DEPTH (MM)	WEIGHT (KG)	MODEL
1000	450	1350	135	12	AH503116
1500	450	1350	135	12	AH503117
2000	450	1575	135	15.5	AH503118

FURNO

PANEL HEATER



Scan me for full technical specification

The Furno panel heater has been designed with a curved front plate featuring an asymmetric design to provide a soft, homogeneous heating which can quickly heat the room up.

Packed with a range of features to make home heating that much easier and equipped with direct Wi-Fi connectivity capabilities.

KEY FEATURES

- ✓ Wi-Fi Connectivity
- ✓ Anti Frost Mode
- ✓ Aluminium Heating Element
- ✓ Open/Closed Window Detection
- ✓ High Precision Electric Thermostat
- ✓ LCD Digital Control Panel

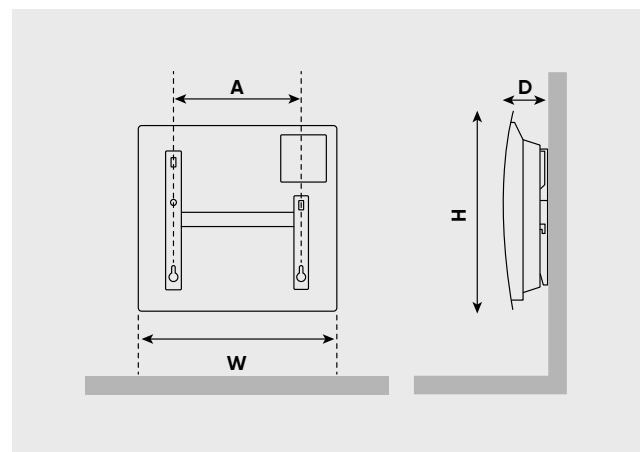

OPEN/CLOSED WINDOW DETECTION

OUTPUT (W)	DEPTH (MM)	WIDTH (MM)	HEIGHT (MM)	WEIGHT (KG)	MODEL
750	130	601	477	8	AH158012
1000	130	601	477	8	AH158013
1500	130	823	477	10	AH158014
2000	130	1045	477	13	AH158015

AGILIA IO

PANEL HEATER



Scan me for full technical specification

Designed with a simplistic and modern symmetrical style, the Agilia IO can work perfectly with any home decor design with complete ease.

Engineered to be slim and compact, the Agilia IO electric panel heater combines comfort, energy, and space-saving benefits into one complete elegant radiator.

KEY FEATURES

- ✓ ErP Lot 20
- ✓ Cozytouch compatible
- ✓ Click & go
- ✓ Open/closed window detection
- ✓ 45% Energy savings*

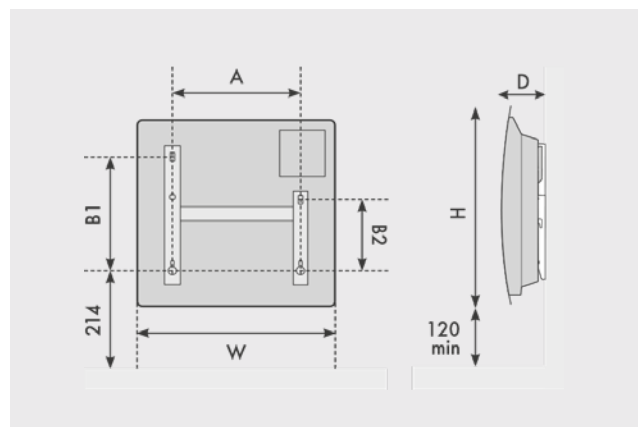

DOUBLE HEATING ELEMENTS

OUTPUT (W)	DEPTH (MM)	WIDTH (MM)	HEIGHT (MM)	A	B1	B2	WEIGHT (KG)	MODEL
500	129	372	530	120.8	246	158.5	5.5	AH503105
750	129	372	530	120.8	246	158.5	5.5	AH503107
1000	129	446	530	194.8	246	158.5	6	AH503110
1250	129	520	530	268.8	246	158.5	7.5	AH503117
1500	138	594	530	342.8	246	158.5	9	AH503115
2000	138	742	530	490.8	246	158.5	9	AH503120

* When compared to an analogue electric radiator

SENSIS

ELECTRIC TOWEL RAIL

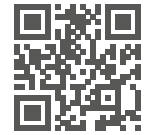

Scan me for full technical specification

The Sensis electric towel rail features our specially formulated thermofluid technology, offering fast heat-up times and gentle, soft heat distribution. Designed with comfort and simplicity in mind, it includes an integrated programmer and adjustable thermostat, providing the user with full heating flexibility.

KEY FEATURES

- ✓ ErP Lot 20
- ✓ 25% energy savings*
- ✓ Thermofluid technology
- ✓ Digital display
- ✓ 2 year warranty

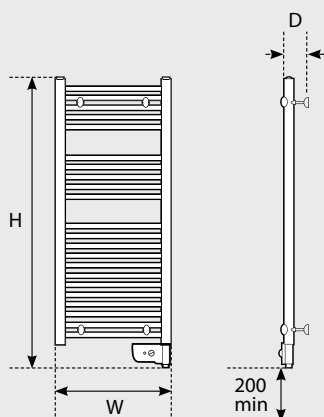

**BOOST
FUNCTION**

OUTPUT (W)	DEPTH (MM)	WIDTH (MM)	HEIGHT (MM)	WEIGHT (KG)	MODEL
200	100	400	584	6	AH100836
300	100	400	720	7	AH100837
500	100	500	884	9	AH100838

* When compared to an analogue electric radiator

ATLANTIC CHROME

ELECTRIC TOWEL RAIL



Scan me for full technical specification

The Atlantic Chrome towel rail uses thermofluid technology to deliver fast homogeneous long-lasting heat. Incorporating a 2-hour boost mode and a 24-hour automatic mode, with a heating light indicator offering complete comfort. Designed to be modern and easy to install, the Atlantic Chrome towel rail features three wall fittings for fast and easy installation.

KEY FEATURES

- ✓ ErP Lot 20
- ✓ 25% Energy Savings*
- ✓ Thermofluid technology
- ✓ Boost function
- ✓ 2 year warranty

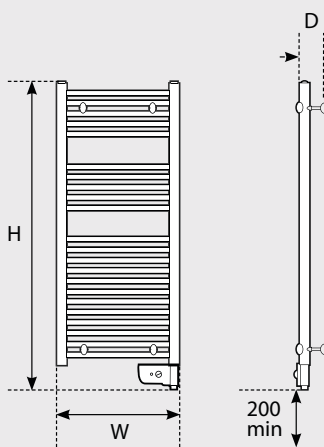
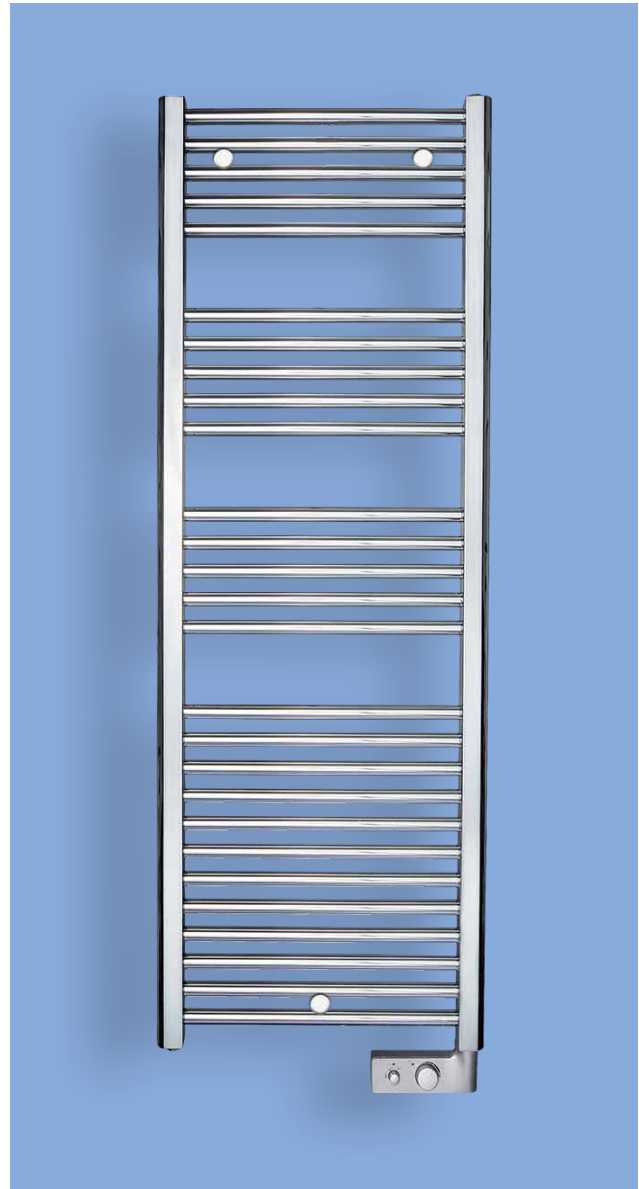

**EASY
INSTALLATION**

OUTPUT (W)	DEPTH (MM)	WIDTH (MM)	HEIGHT (MM)	WEIGHT (KG)	MODEL
300	63	500	910	11.7	AH571714
500	63	480	1445	16.5	AH571716

* When compared to an analogue electric radiator

CALYPSO

HEAT PUMP HOT WATER HEATER



Scan me for full technical specification

Utilising heat pump technology to efficiently heat hot water, the Calypso features an adjustable air inlet and outlets to provide easy installation and is Cozytouch compatible allowing users to control the Calypso from their smart device with ease.

KEY FEATURES

- ✓ ErP rating: A+
- ✓ Over 300% efficient
- ✓ Low noise emission: 49db
- ✓ Duplex stainless steel tank
- ✓ Cozytouch compatible

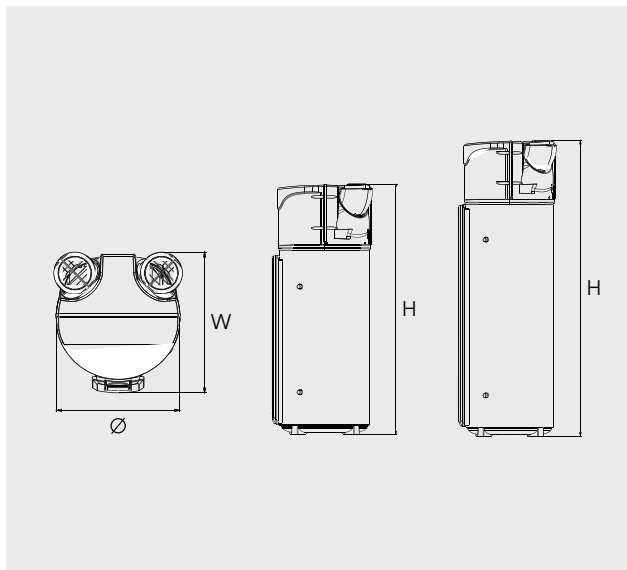

INTEGRATED
AIR SOURCE
HEAT PUMP

SIZE (L)	HEIGHT (MM)	WIDTH (MM)	DIAMETER (MM)	WEIGHT (KG)	HEATING TIME (10°C TO 54°C)	HEAT LOSS (kWhr/24hr)	COP	MODEL
172	1700	695	605	83.6	5H 48	1.23	3.15	AH876509
210	1940	695	605	84	7H 18	1.39	3.02	AH886123

HOW IT WORKS

Using modern technology, our heat pump system draws ambient air from the environment to produce heat efficiently. This heat is then circulated around the cylinder to create hot water for the property.

1. CAPTURE

The fan passes ambient air over extremely cold liquid refrigerant. The refrigerant captures the heat from the ambient air and becomes a warm vapour.

2. COMPRESS

The warm refrigerant vapour passes through a compressor, raises the temperature and produces hot refrigerant and usable heat.

3. EXCHANGE

The heat in the hot refrigerant is transferred to the cold water stored within the duplex stainless steel tank through the heat exchanger, which is around the outside of the tank, to supply hot water to the property.

4. EXPAND

Once the heat has been transferred to the cylinder to heat the water, the refrigerant passes through an expansion valve. This reduces its temperature, making it cold again and enabling it to capture heat from the ambient air, continuing the cycle.

26%

thicker insulation than other heat pump hot water heaters on the market

Over

300%

energy efficient COP rating

Calypso has one of the

lowest

standing heat losses on the market

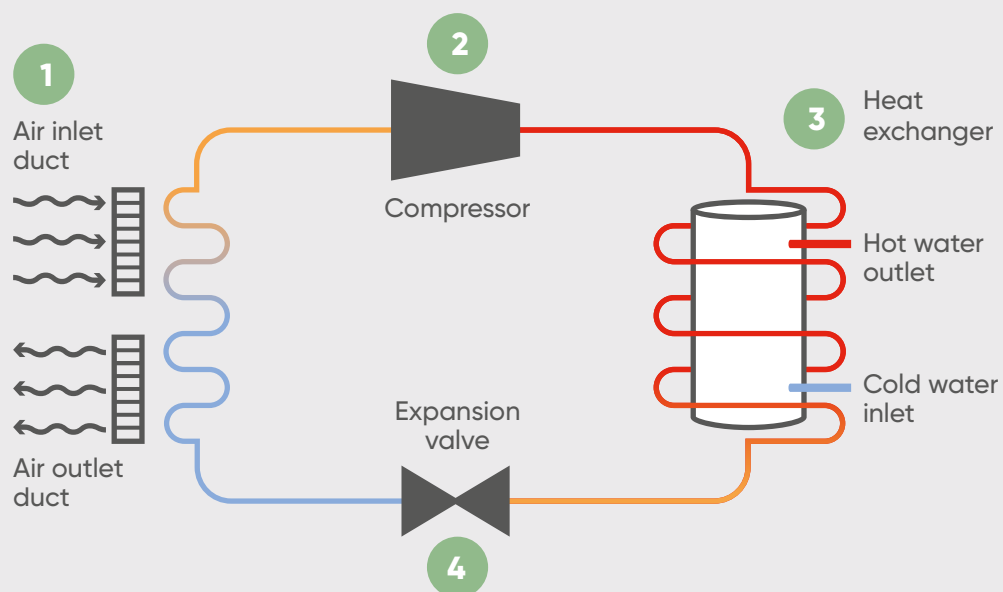

COZYTOUCH: INTELLIGENT PROGRAMMING

Atlantic's range of Cozytouch compatible electric heating appliances features built-in motion sensor technology on the front of each unit. This allows the electric radiator to detect whether someone is in the room and automatically adjust itself to the ideal temperature. If the system detects no movement within the room, the electric heating appliance will automatically lower its temperature output to an economy setting, reducing energy consumption and running costs.

Setting up the Cozytouch system is simple, with no complicated programming required. During the first week of operation, the Cozytouch electric radiator scans and monitors the room to detect patterns of usage and builds an intelligent daily

schedule based on these patterns. This means that each room (or zone) is warmed up before it becomes occupied, providing comfort and luxury with ease. The Cozytouch smart system repeats its automatic daily and weekly scans to continuously adapt to the user's lifestyle.

In addition to this, Cozytouch also provides the user with real-time monitoring capabilities and full control over their heating. The user can remotely control each appliance individually within the property, making it easy to adjust heating settings and reduce energy usage.

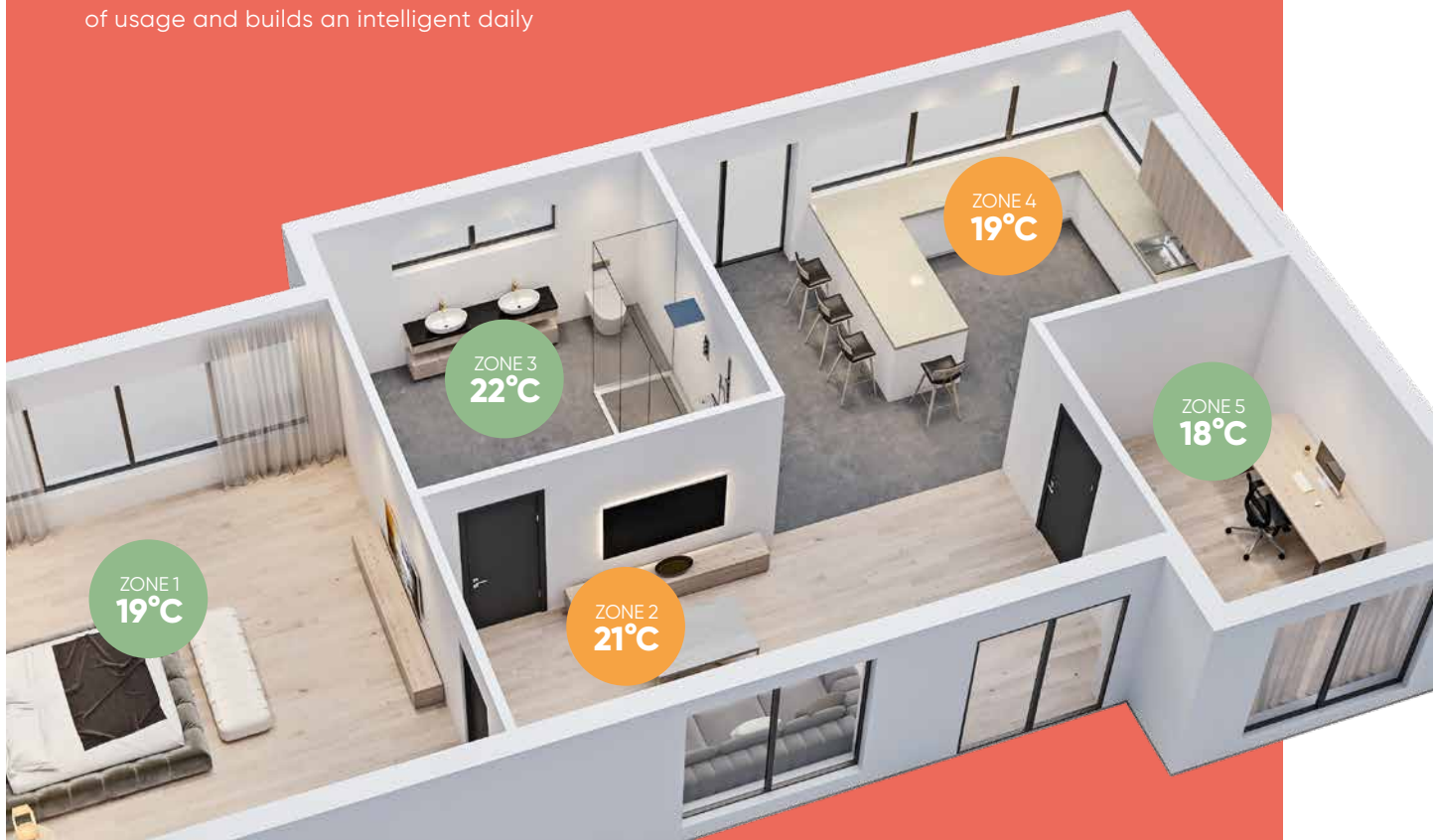

COZYTOUCH

CONTROL SYSTEM



Scan me for full technical specification

Cozytouch is a home heating control device that offers connectivity to all compatible Atlantic electric heating systems in the house. Offering simplicity and ease to the user, the Cozytouch offers the use the ability to control their heating applicable remotely whilst providing real time monitoring capabilities, energy consumption, absence and open window detection.

KEY FEATURES

- ✓ Compact design
- ✓ Versatile design
- ✓ Real time monitoring capabilities
- ✓ Temperature room zone control
- ✓ Savings report overview



LENGTH (MM)	WIDTH (MM)	DEPTH (MM)	WEIGHT (G)	MODEL
172	72	16	133	AH001231

COMPATIBLE PRODUCTS			
AGILIA IO	ONIRIS	GALAPAGOS	CALYPSO
			

ideal
HEATING

idealheating.com

Customer Service: 01482 498660

Technical Help: 01482 498663

E: enquiries@idealheating.com

Ideal Heating, PO Box 103, National Avenue,
Kingston upon Hull, East Yorkshire, HU5 4JN

G | **GLEDHILL**

gledhill.net

T: 01253 474550

E: enquiries@gledhill.net

Gledhill Building Products Limited
Sycamore Estate, Squires Gate,
Blackpool FY4 3RL

atlantic

atlanticheat.co.uk

T: 0844 3350 549

E: enquiries@atlantic-heat.co.uk

Atlantic | PO Box 103, National Avenue,
Kingston Upon Hull, HU5 4JN