



# INSTALLATION & SERVICING

## **THERMSTORE & SOLAR THERMSTORE**

When replacing any part on this appliance, use only spare parts that you can be assured conform to the safety and performance specification that we require. Do not use reconditioned or copy parts that have not been clearly authorised by Ideal Heating. For the very latest copy of literature for specification and maintenance practices visit our website [idealheating.com](http://idealheating.com) where you can download the relevant information in PDF format.



These instructions should be read in conjunction with the installation/servicing instructions issued by the manufacturer of the heat source being used.

Any installation must be in accordance with the relevant requirements of the Gas Safety Regulations, Building Regulations, I.E.E. Wiring Regulations and the Water Fitting Regulations (England and Wales) or Water Byelaws (Scotland). It should be read in accordance with the relevant recommendations of the following:  
BS 6798; BS EN 12828, BS EN 12831, BS EN 14336; BS 5546;  
BS 5440:1; BS 5440:2; CP 331:3  
BS EN 806-1 to 5, BS EN 8558:2011; BS EN 1458-1:2011 and BS 7593:2006

Thermstore is covered by Section G3 of the Building Regulations (England and Wales) Technical Standard P3 (Scotland) and Building Regulation P5 (Northern Ireland). Compliance can be achieved via a Competent Person Self Certification Scheme or notification of installation to the Local Authority Building Control Department.

It must be installed by a competent person as defined by the relevant regulations. Manufacturers notes must NOT be taken as over-riding statutory obligations.

This appliance is not intended for use by persons (including children) with reduced physical, sensory or mental capabilities, or lack of experience and knowledge unless they have been given supervision or instruction concerning use of the appliance by a person responsible for their safety. Children should be supervised at all times to ensure they do not play with the appliance.

This information is provided to assist generally in the selection of equipment. Responsibility for selection and specification of our equipment must however remain that of our customer and any experts or consultants concerned with the installation(s).

**Please note: that we do not therefore accept any responsibility for matters of design selection or specification, for the effectiveness of an installation or system containing one of our products unless specifically requested to do so in writing.**

All goods are sold subject to our Conditions of Sale which are set out at the rear of this specification. In the interest of continuously improving the Thermstore range, Ideal Boilers reserve the right to modify the product without notice, and in these circumstances this booklet, which is accurate at the time of printing, should be disregarded. An updated set of Instructions will be produced and supplied with new appliances and will be made available for other appliances on request.

**Thermstore is produced under an ISO 9001:2008 Quality Management System approved by BSI.**



Benchmark places responsibilities on both manufacturers and installers. The purpose is to ensure that customers are provided with the correct equipment for their needs, that it is installed, commissioned and serviced in accordance with the manufacturers instructions by competent persons and that it meets the requirements of the appropriate Building Regulations. The Benchmark Checklist can be used to demonstrate compliance with Building Regulations and should be provided to the customer for future reference.

<b>Section</b>	<b>Page</b>
<b>DESIGN</b>	
Description	3
Technical Information	6
System Design	8
<b>INSTALLATION</b>	
Installation	10
Commissioning	22
<b>SERVICING AND MAINTENANCE</b>	
Servicing and Maintenance	23
Fault Finding	25
Short Parts List	27
<b>APPENDIX</b>	
Appendix	28
Terms & Conditions	29
Benchmark Checklist	30
Benchmark Service Record	31

## Manufacturer: Ideal Boilers

Maximum inlet pressure to Pressure reducing valve	12 bar
Operating pressure (PRV setting)	3 bar
Expansion vessel charge pressure	3 bar
Expansion relief valve setting	4.5 bar
Opening pressure of P & T Relief Valve	6 bar
Opening temperature of P & T Relief Valve	95°C
Energy cut-out thermostat setting	85°C
Max. working pressure - Primary heat exchanger (Indirect models)	3 bar
Max. working pressure - Solar heat exchanger (Solar models)	6 bar
Immersion heater rating	3kW, 240V AC

All cylinders are manufactured in accordance with the requirements of BS EN 12897. The tundish must be positioned so that it is visible to the occupant and is away from electrical devices.

Components supplied with Thermstore:

- Cold water inlet PRV combination valve/expansion relief
- Pressure and temperature relief valve
- Control thermostat
- Energy cut-out thermostat
- Energy cut-out motorised valve (indirects only)
- Tundish
- Drain elbow and 90 degree elbow
- 3kW Immersion heater including control and cut out thermostats
- Expansion vessel/mounting bracket
- Technical/user product literature

**(Note:** Please refer to table on pages 6-7 to confirm the quantity of immersion heaters supplied with the unit)

**In any situation where the volume of heated pipework (eg. secondary circulation pipes or manifold pipework for multiple units) exceeds 10 litres, then an additional expansion vessel must be fitted to accommodate the extra expansion volume.**

## Handling Before Installation

Thermstore must be handled with care and stored the correct way up in a dry place. Any manual handling/lifting operations will need to comply with the requirements of the Manual Handling Operations Regulations issued by the H.S.E. The appliance can be moved using a sack truck on the rear face although care should be taken and the route should be even. In apartment buildings containing a number of storeys we would recommend that the appliances are moved vertically in a mechanical lift. If it is proposed to use a crane, expert advice should be obtained regarding the need for slings, lifting beams etc.

A specific manual handling assessment is shown in Appendix at the rear of this manual.

## The Environment

This product has been manufactured using many recyclable materials, including the approved HCFC/CFC free polyurethane foam insulation. At the end of its useful life, it should be disposed of at a Local Authority Recycling Centre, to maximise the products full environmental benefits.

## Maintenance

Modifications should not be made to this product. Replacement parts, including immersion heaters, should be purchased from Ideal Boilers, or agents approved by them. Unvented hot water storage vessels need regular routine checks, and these are detailed below. It is for this reason that this manual must always be left with the Thermstore.

It is essential that these checks be carried out at the time of boiler maintenance by a qualified installer:

1. Manually open the relief valves in turn, and check that water is discharged from the valves and runs freely through the tundish and out at the discharge point. Ensure that the valves re-seat satisfactorily. (Note - the water may be very hot).
2. It is important to check that the discharge pipework is carrying the water away adequately. Check for blockages etc. if it is not.
3. Isolate the cold supply to the cylinder. Remove the inlet control valve. Inspect the gauge filter on the inlet side and remove any debris.
4. Check the charge pressure in the expansion vessel and repressurise if required
5. Re-fill the system and ensure that all relief valves have re-seated.
6. The Benchmark Service Record should be updated at each service.
7. Check the water pressure downstream of the combination valve is 3 bar in static condition.
8. Check and if necessary, descale the heat exchanger in hard water areas ie. above 200ppm (mg/l).

## Note:

The cylinder is factory fitted with a temperature & pressure relief valve that must not be used for any other purpose or removed.

The cylinder is factory fitted with immersion heaters with thermal cut outs. Immersions without thermal cut outs must not be fitted.

# DESIGN

**Figure 1**

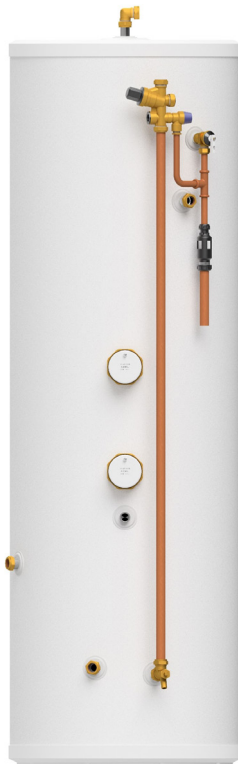

**Thermstore  
INDIRECT**

Thermstore is a range of indirect unvented hot water storage cylinders, manufactured in the latest high quality duplex stainless steel. They are designed to provide mains pressure hot water and are supplied as a package which complies with Section G3 of the Building Regulations. The appliance is extremely well insulated using high density HCFC free foam insulation with an ozone depleting potential (ODP) of zero and a global warming potential (GWP) of 2. It is fitted with all necessary safety devices and supplied with all the necessary control devices to make installation on site as easy as possible.

**Thermstore is available in two basic variants:**

1. **Thermstore Indirect** - For use with gas or oil boilers (Figure 1). Unvented cylinders must not be used with solid fuel boilers or steam as the energy source.
2. **Thermstore Indirect Solar** - For providing hot water by solar gains and gas or oil boilers (Figure 2). Unvented cylinders must not be used with solid fuel boilers or steam as the energy source.

**Thermstore Indirect**

Thermstore Indirect is an unvented hot water storage cylinder and is provided with a high efficiency internal primary coil which is designed for use with a gas or oil boiler and is suitable for both open vented and sealed pumped primary systems.

When used with a sealed heating system the boiler must incorporate its own energy cut-out overheat thermostat.

Thermstore Indirect models are listed in table on Page 6 & 7.

# DESIGN

**Figure 2**

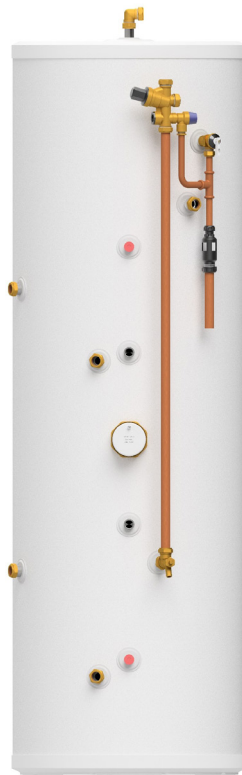

**Thermstore  
INDIRECT SOLAR**

## **Thermstore Indirect Solar**

Thermstore Indirect Solar is an unvented hot water storage cylinder and is provided with a high efficiency internal primary coil which is designed for use with a gas or oil boiler and is suitable for both open vented and sealed pumped primary systems.

When used with a sealed heating system the boiler must incorporate its own energy cut-out overheat thermostat.

A high efficiency solar coil is positioned below the primary coil to ensure maximum benefit of solar gain energy.

Thermstore Indirect Solar models are listed in table on Page 6 & 7.

### **Note:**

**The cold supply elbow c/w drain tapping must be fitted as shown in figs 1 and 2. A flexible hose can then be connected to the drain tapping. The cylinder contents can be drained to the tapping level. This is adequate for all servicing requirements. If the cylinder is being disconnected and removed then it may be tilted to drain and water remaining in the cylinder.**

# DESIGN

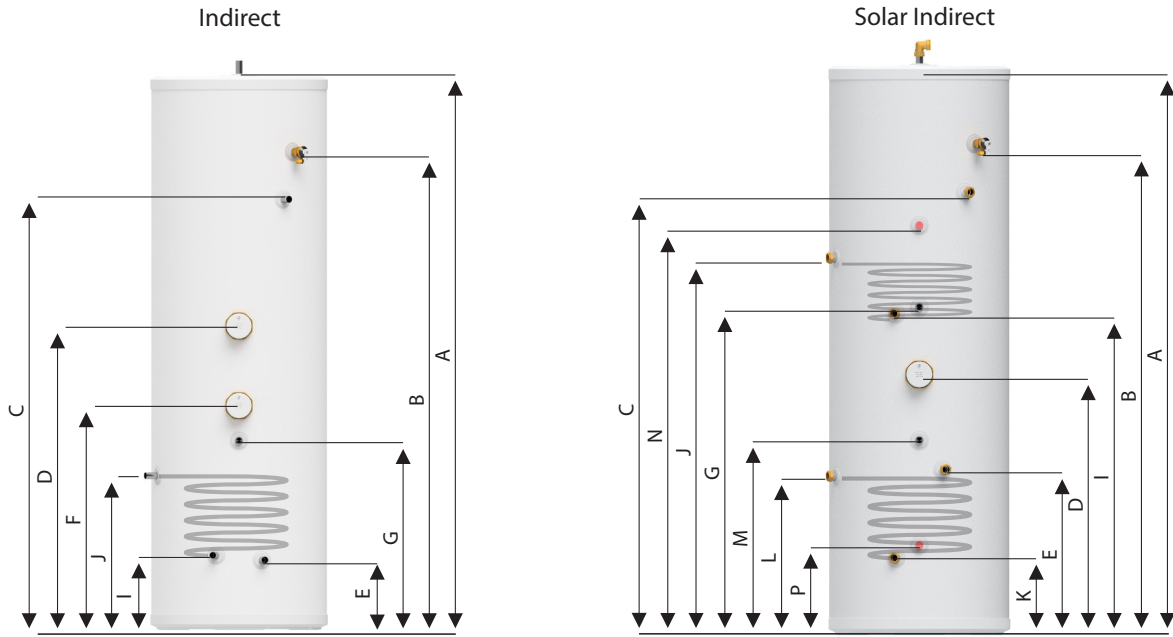
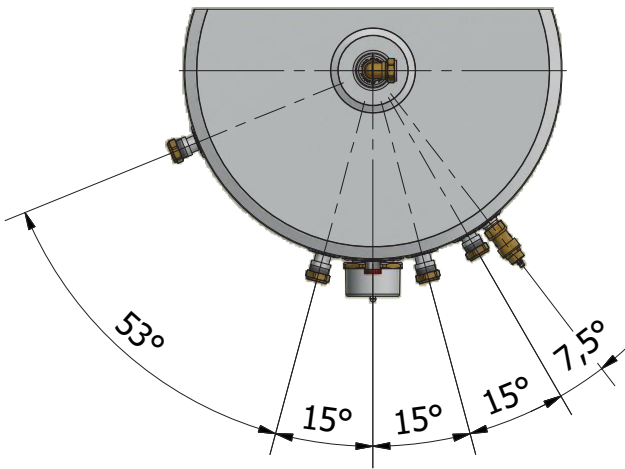

**Table 1**

Model	Stock Code	Energy Efficiency Class	Heat Loss		Capacity (Total Volume) Litres	Weight - Empty kg	Weight - Full kg	Pressure Regulator 3 bar inlet group c/w balance cold supply, expansion vessel connection and expansion valve set at 4.5 bar bar	Expansion Vessel size. Pre-charged to 3 bar Litres	Overall Height A=mm	Overall Diameter mm	Pressure & Temperature Relief Valve B=mm	22mm Secondary Return Tapping C=mm
			Watts	kWh/24hr									
<b>Thermstore</b>													
90	IDEPLUIN090	A	32	0.77	91	20	111	3	12	764	550	522	n/a
120	IDEPLUIN120	B	39	0.94	119	23	142	3	12	931	550	689	n/a
150	IDEPLUIN150	B	47	1.13	148	26	174	3	18	1118	550	876	n/a
180	IDEPLUIN180	B	55	1.32	178	30	208	3	18	1306	550	1064	n/a
210	IDEPLUIN210	B	62	1.49	208	33	241	3	24	1494	550	1252	1141
250	IDEPLUIN250	C	74	1.78	248	38	286	3	24	1744	550	1502	1353
300	IDEPLUIN300	C	86	2.06	287	43	330	3	35	1990	550	1748	1562
400	IDEPLUIN400	C	87	2.09	393	55	455	3	2 x 24	2030	630	1787	1595
<b>Solar Thermstore</b>													
180	IDEPLUIN180S	B	55	1.32	178	31	209	3	18	1306	550	1064	n/a
210	IDEPLUIN210S	B	62	1.49	208	35	243	3	24	1494	550	1252	1141
250	IDEPLUIN250S	C	74	1.78	248	40	288	3	24	1744	550	1502	1353
300	IDEPLUIN300S	C	86	2.06	287	44	331	3	35	1990	550	1748	1562
400	IDEPLUIN400S	C	87	2.09	393	59	459	3	2 x 24	2030	630	1784	1592

# DESIGN

## NOTES



1. Not all models - see table 1.
2. Recovery times based on Primary Coil/I.H. duty (ie. assumes the boiler output is adequate).
3. All connections are supplied with compression fittings for direct connection to copper pipework.
4. The diagrams shown are generic. For exact product specification refer to the table eg. the number of immersion heaters varies depending on model.
5. Heat up and recovery times based on 0.25 l/s primary flow rate and at 82°C flow temperature.

On Peak Immersion Heater - High Level	Cold Feed 22mm Compression Connection	Off Peak Immersion Heater - Low Level	Volume of On Peak Water Heated	Dual Control & Overheat Stat	22mm Primary Return Compression Connection (28mm tails for 400 litre model)	22mm Primary Flow Compression Connection (28mm tails for 400 litre model)	22mm Solar Return Compression Connection	22mm Solar Flow Compression Connection	Dual Control & Overheat Stat	Solar Pocket	Solar Pocket	Second Off Peak Immersion Heater - Low Level	kW Rating of Primary Coil	Surface Area of Primary Heater Coil	Pressure Loss Across Primary Heater Coil	Surface Area of Solar Heater Coil	Pressure Loss Across Solar Heater Coil	Heat Up Time from 15°C to 60°C (applies to Primary Heat Source only)	Dedicated Solar Volume
D=mm	E=mm	F=mm	Litres	G=mm	I=mm	J=mm	K=mm	L=mm	M=mm	N=mm	P=mm	R=mm	kW	m <sup>2</sup>	bar	m <sup>2</sup>	bar	min	Litres
382	220	n/a	45.1	272	235	325	n/a	n/a	n/a	n/a	n/a	n/a	16.5	0.59	0.165	n/a	n/a	17	n/a
437	220	n/a	63.1	327	235	325	n/a	n/a	n/a	n/a	n/a	n/a	18	0.59	0.165	n/a	n/a	21	n/a
499	220	n/a	83.2	389	235	365	n/a	n/a	n/a	n/a	n/a	n/a	18.5	0.68	0.191	n/a	n/a	25	n/a
561	220	n/a	103.4	451	235	405	n/a	n/a	n/a	n/a	n/a	n/a	19	0.78	0.216	n/a	n/a	30	n/a
632	220	n/a	123.7	513	235	405	n/a	n/a	n/a	n/a	n/a	n/a	20.5	0.78	0.216	n/a	n/a	32	n/a
955	220	705	110.5	595	235	485	n/a	n/a	n/a	n/a	n/a	n/a	21.5	0.97	0.241	n/a	n/a	36	n/a
1092	220	786	128.5	676	235	485	n/a	n/a	n/a	n/a	n/a	n/a	25	0.97	0.241	n/a	n/a	38	n/a
1117	566	799	180	669	235	546	n/a	n/a	n/a	n/a	n/a	n/a	30.5	1.27	0.31	n/a	n/a	41	n/a
693	385	n/a	82.2	859	879	969	235	365	451	941	220	n/a	18	0.59	0.165	0.68	0.191	28	96
736	385	n/a	105.5	922	922	1052	235	365	513	1064	243	n/a	18.5	0.68	0.191	0.68	0.191	35	101
796	505	n/a	136	1002	982	1152	235	485	595	1252	275	n/a	19	0.78	0.216	0.97	0.241	38	107
922	505	n/a	155.3	1128	1108	1278	235	485	676	1128	305	n/a	20.5	0.78	0.216	0.97	0.241	41	125
872	557	n/a	190	1060	930	1190	238	548	651	1383	357	n/a	22	0.97	0.241	1.27	0.31	45	165

# DESIGN

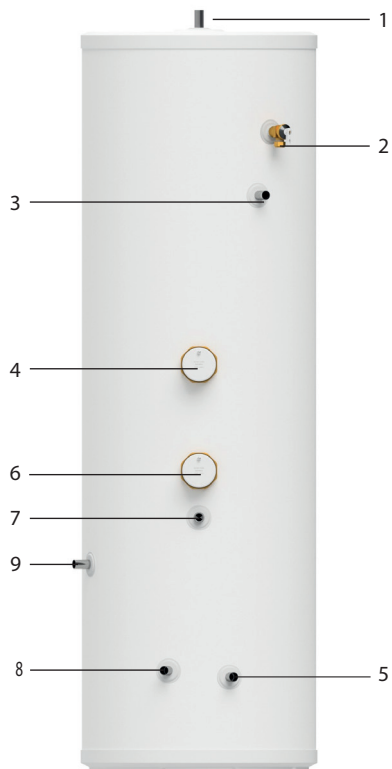

## Thermstore Indirect

### Basic Appliance

1. Hot water draw off (22mm) compression
2. Temperature & pressure relief valve 95°/6 bar
3. Hot water secondary return 22mm (not fitted to smaller sizes, see table 1)
4. Immersion heater 1¾" BSP 3kW
5. 22mm cold supply compression
6. Immersion heater 1¾" BSP 3kW
7. Dual control/overheat stat pocket (22mm)
8. Primary return (22mm)  
- (28mm tails for 400 litre models)
9. Primary flow (22mm)  
- (28mm tails for 400 litre models)

### Part G3 loose components supplied in a separate box

- A. Combination inlet group incorporating pressure reducing valve, strainer, check valve, balance cold take off point, expansion relief valve and expansion vessel connection points.
- B. Potable expansion vessels c/w integral wall bracket
- C. Tundish
- D. Drain elbow
- E. Compression fittings
- F. Dual control thermostat and combined overheat thermostat
- G. Two port (22mm) zone valve for primary circuit



# DESIGN

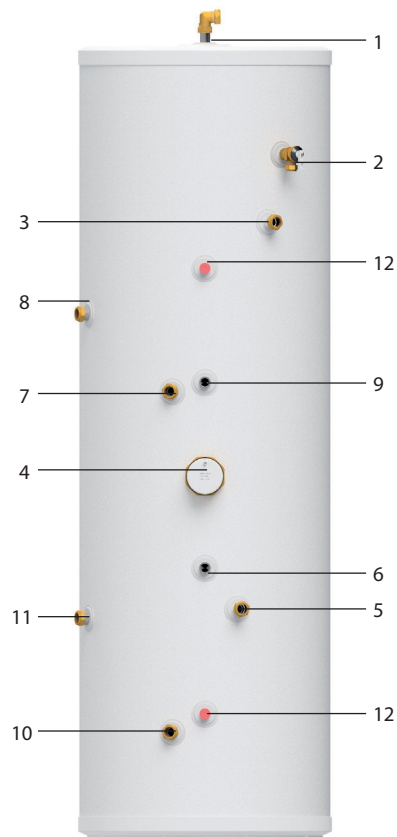

## Thermstore Indirect Solar

### Basic Appliance

1. Hot water draw off (22mm) compression
2. Temperature & pressure relief valve 95°/6 bar
3. Hot water secondary return 22mm (not fitted to smaller sizes, see table 2)
4. Immersion heater 1 $\frac{3}{4}$ " BSP 3kW
5. 22mm cold supply
6. Dual control/Overheat stat pocket (solar)
7. Primary return (22mm)  
- (28mm tails for 400 litre models)
8. Primary flow (22mm)  
- (28mm tails for 400 litre models)
9. Dual control/Overheat stat pocket (boiler)
10. Solar coil return to panel collector (22mm) compression
11. Solar coil flow from panel (22mm) compression
12. Solar thermostat pocket

### Part G3 loose components supplied in a separate box

- A. Combination inlet group incorporating pressure reducing valve, strainer, check valve, balance cold take off point, expansion relief valve and expansion vessel connection points.
- B. Potable expansion vessels c/w integral wall bracket
- C. Tundish
- D. Drain elbow
- E. Compression fittings
- F. Dual control thermostat and combined overheat thermostat
- G. Two port (22mm) zone valve for primary circuit

# INSTALLATION

## General Design Considerations

The cupboard footprint needs to be at least 650mm square for standard units up to 300 litres, 730mm for 400 litre and 575mm for slimline units. The base chosen for the cylinder should be level and capable of supporting the weight of the unit when full of water as shown in General Data. The discharge pipework for the safety valves must have a minimum fall of 1 : 200 from the unit to a safe discharge point. All exposed pipework and fittings on the cylinder should be insulated, and the unit should NOT be fixed in a location where the contents could freeze.

In new systems, pipes should be insulated to comply with building regs, the maximum permissible heat loss is indicated in the table opposite, and labelled accordingly as follows:

- i. Primary circulation pipes for domestic hot water circuits should be insulated through their length, subject only to practical constraints imposed by the need to penetrate joists and other structural elements.
- ii. All pipes connected to hot water storage vessels, including the vent pipe, should be insulated for at least 1 metre from their points of connection to the cylinder (or they should be insulated up to the point where they become concealed).

In replacement systems, whenever a boiler or hot water storage vessel is replaced in an existing system, any pipes that are exposed as part of the work or are otherwise accessible should be insulated as recommended for new systems, or to some lesser standard where practical constraints dictate.

**The pipe connecting the boiler flow to the appliance must not be less than 22mm copper or equivalent.**

Standard and Slimline Model Selection Guide		
Max hot water demand	Max number of bed spaces (Bedrooms)	Indirect litres
1 shower room	Bedsit (0)	90
1 bathroom	2 (2)	120
1 bathroom	4 (3)	120
1 bathroom + separate shower room	6 (4)	150
1 bathroom + 2 separate shower rooms or 2 bathrooms	7 (5)	180
2 bathrooms + separate shower room	7 (5)	210
2 bathrooms + 2 separate shower rooms	7 (5)	250
3 bathrooms + 2 separate showers rooms	9 (6)	300
3 bathrooms + 3 separate showers rooms	9 (6)	400

Solar Model Selection Guide		
Max hot water demand	Bedrooms	Indirect litres
1 shower room	Bedsit	180
1 bathroom	1-3	180
1 bathroom + 1 shower room	1-3	210
1 bathroom + 2 shower rooms	2-4	250
2 bathrooms + 1 shower room	3-4	300
2 bathrooms + 2 shower rooms	4-5	400

Insulation of pipework	
Pipe outside diameter	Maximum heat loss
15mm	7.89W/m
22mm	9.12W/m
28mm	10.07W/m
35mm	11.08W/m

Further guidance on converting heat loss limits to insulation thickness for specific thermal conductivities is available in TIMSA "HVAC guidance for achieving compliance with Part L of the Building Regulations".

## Mains Water Supply

Existing properties with a 15mm supply will be satisfactory provided the local mains pressure is good, but should be confined to single bathroom properties. For new properties where simultaneous demand is required to more than one bathroom or a bathroom and one or more en-suites, the communication and service pipe into the dwelling should be a minimum of 22mm (usually in the form of a 25mm MDPE supply). The optimum performance is achieved if the inlet pressure is 3 bar dynamic. However, the Thermstore will function with lower inlet pressures, but this will reduce the performance. For optimum performance, 30L per minute incoming mains flow should be present, however the Thermstore will work at lower flow rates, although performance will be affected. Normally Thermstore provides well in excess of 40 litres/min in most conditions. Flow rates for ALL mains pressure systems are subject to district pressures and system dynamic loss. Particularly on larger properties with more than one bathroom, the pipe sizes should be calculated in accordance with BS EN 806-3:2006 and BS 8558:2011.

## Model Selection

The suggested model sizes are based on typical hot water usage. For high specification dwellings an increase of one model size should be considered.

# INSTALLATION

## General Restrictions

- The highest hot or cold water draw off point should not exceed 10 metres above the Pressure Reducing Valve.
- An ascending spray type bidet or any other appliance with a Class 1 back-siphonage risk requiring a type A air gap should not be used.
- Thermstore should not be used where steam is the primary heating medium, or in a situation where maintenance is likely to be neglected.
- Unvented cylinders are not suitable for use with solid fuel boilers.
- If the supply to the mixer fittings (other than a dual outlet type) is not taken from the balanced supply the system will become over pressurized and cause the pressure relief valve to discharge. Over time this could also cause the premature failure of the appliance itself which will not be covered by the warranty.**
- In larger properties with a number of bathrooms/en-suites and long pipe runs we would recommend that the balance cold supply is provided with its own pressure reducing valve and is not taken from the balanced cold connection on the combination valve. In this case it will also be necessary to fit a small expansion vessel on the balanced cold water system to accommodate the pressure rise caused by the increase in temperature of the balanced cold water.
- Check the performance requirements of the terminal fittings with regard to flow/pressure are suitable.
- In relation to potable water systems, expansion vessels shall be installed in a vertical orientation and located so that the length of the connecting pipe work is kept to a minimum.

## Shower Fittings

Aerated taps are recommended to prevent splashing. Any type of shower mixing valve can be used as long as both the hot and cold supplies are mains fed. However, all mains pressure systems are subject to dynamic changes particularly when other hot and cold taps/showers are opened and closed, which will cause changes in the water temperature at mixed water outlets such as showers. For this reason and because these are now no more expensive than a manual shower we strongly recommend the use of thermostatic showers with this appliance. These must be used in 3 storey properties where the impact on pressure/temperature of opening another tap in the system is greater than normal. The shower head provided must also be suitable for mains pressure supplies.

## Pipe Layout

In all mains pressure installations it is important to remember that the incoming cold supply must be shared between all terminal fittings. It is important that a 22mm supply is brought to the appliance and a 22mm take-off is continued at least to the bath. If there are two baths, 28mm pipework should be considered. One metre of smaller diameter pipework, or flow restrictors, should be provided on the final connection to all outlets so as to balance the water available. In any event the distribution pipework should generally be in accordance with BS EN806-1 to 5.

## Plastic Pipework

This appliance is suitable for use with plastic pipework as long as the material is recommended for the purpose by the manufacturer and is installed fully in accordance with their recommendations.

## Secondary Hot Water Circulation

All models 210 litres and above are fitted with a secondary return tapping as standard (see table on page 6 & 7 for details). If fitted, an extra expansion vessel may be necessary. A non-return valve MUST be FITTED near the return connection. No valve or terminal fitting should be installed between the non return valve and the cylinder. (See schematic arrangement on page 13.) All pipes kept hot by the secondary circulation should be insulated.

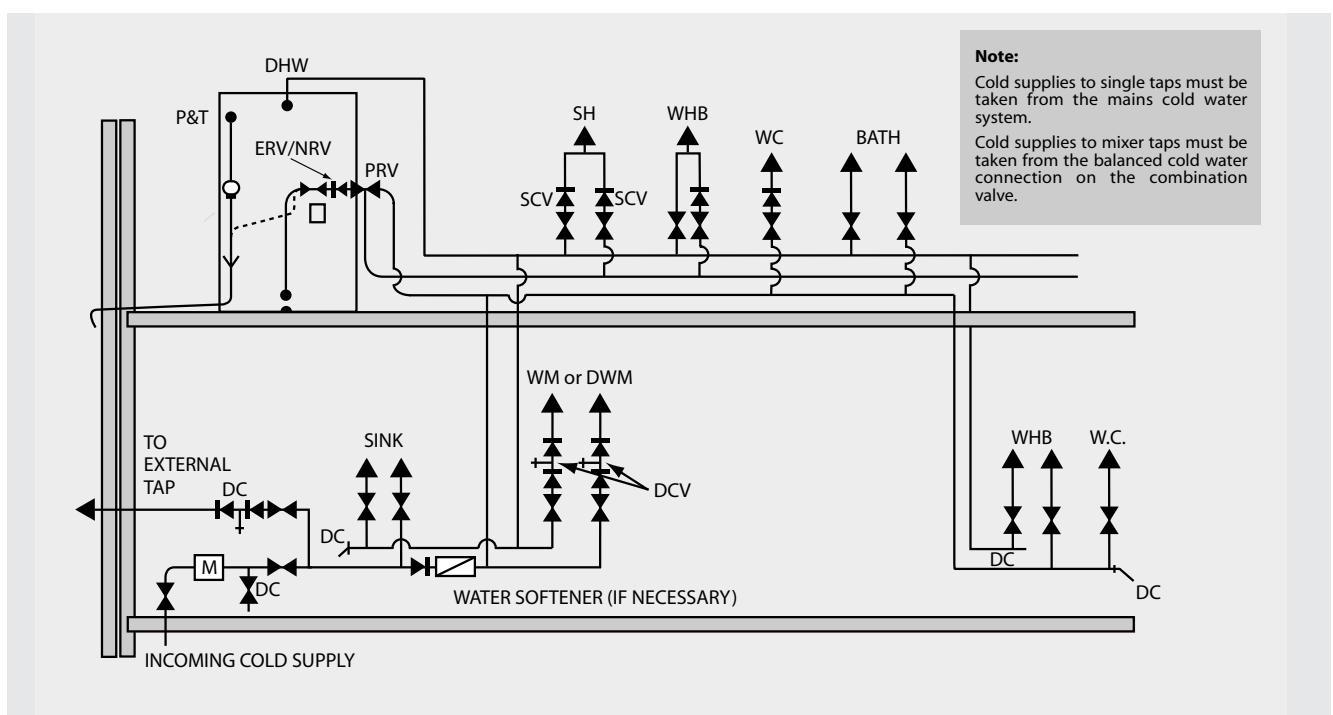

# INSTALLATION

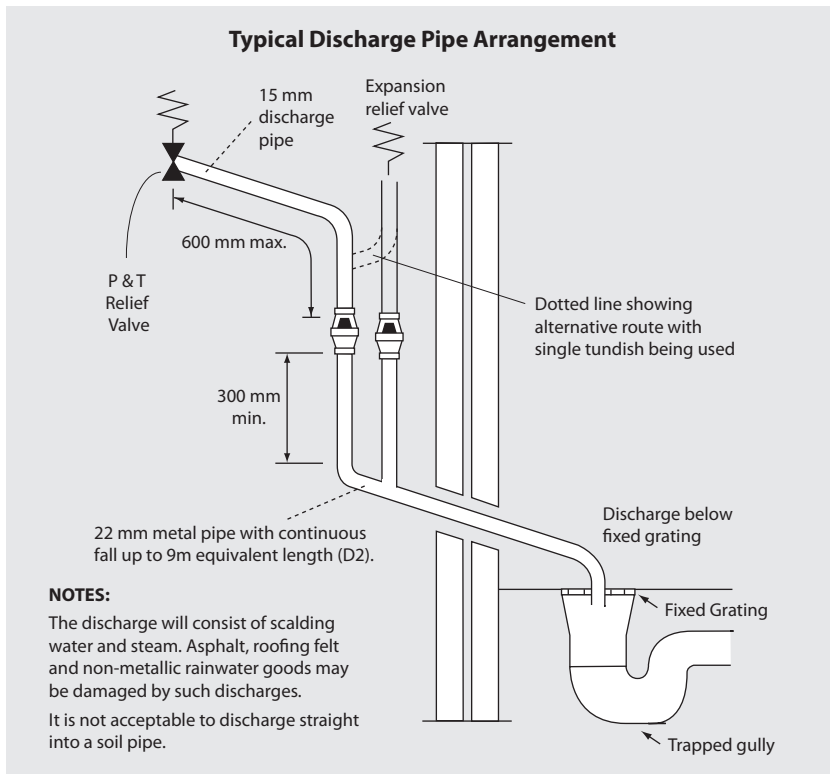

## Pressure & Temperature/expansion Relief Valve Pipework

The relief valve should be installed to discharge in accordance with G3 of the Approved Document of the Building Regulations and should be piped to where it is visible, but will not cause danger to persons or damage to materials.

The following information is taken from Approved Document G3 of the Building Regulations and is provided to assist with the design and installation of the discharge pipework. However, the information is not exhaustive and reference should always be made to Approved Document G3 of the Building Regulations. The final decision regarding any arrangements rests with Building Control and it is recommended that their advice is sought if you have any concerns regarding this aspect of the installation.

The two safety valves will only discharge water under fault conditions. When operating normally water will not be discharged.

The tundish should be vertical, located in the same space as the unvented hot water storage system and be fitted as close as possible and within 600mm of the safety device e.g. the temperature relief valve.

The discharge pipe (D2) from the tundish should terminate in a safe place where there is no risk to persons in the vicinity of the discharge, be of metal and:

- a) Be at least one pipe size larger than the nominal outlet size of the safety device unless its total equivalent hydraulic resistance exceeds that of a straight pipe 9m long i.e. discharge pipes between 9m and 18m equivalent resistance length should be at least two sizes larger than the nominal outlet size of the safety device, between 18 and 27m at least 3 sizes larger, and so on. Bends must be taken into account in calculating the flow resistance. Refer to the table and the worked example.

An alternative approach for sizing discharge pipes would be to follow BS EN 806-2:2005 Specification for design installation, testing and maintenance of services supplying water for domestic use within buildings and their curtilages.

- b) Have a vertical section of pipe at least 300mm long, below the tundish before any elbows or bends in the pipe work.

- c) Be installed with a continuous fall.

## Worked Example

The example below is for G1/2 temperature relief valve with a discharge pipe (D2) having 4 elbows and length of 7m from the tundish to the point of discharge.

From the table below:

Maximum resistance allowed for a straight length of 22mm copper discharge pipe (D2) from a G1/2 temperature relief valve is: 9m subtract the resistance for 4 x 22mm elbows at 0.8m each = 3.2m.

Therefore the maximum permitted length equates to: 5.8m.

5.8m is less than the actual length of 7m therefore calculate the next largest size.

Maximum resistance allowed for a straight length of 28mm pipe (D2) from a G1/2 temperature relief valve equates to: 14m.

As the actual length is 7m, a 28mm (D2) copper pipe will be satisfactory.

Sizing of copper discharge pipe 'D2' for a temperature relief valve with a G1/2 outlet size (as supplied)		
Size of discharge pipework	Maximum length of straight pipe (no bends or elbows)	Deduct the figure below from the maximum length for each bend or elbow in the discharge pipe
22mm	Up to 9m	0.8m
28mm	Up to 18m	1m
35mm	Up to 27m	1.4m

# INSTALLATION

d) It is preferable for the discharge to be visible at both the tundish and the final point of discharge but where this is not possible or practically difficult there should be clear visibility at one or other of these locations. Examples of acceptable discharge arrangements are:

1. Ideally below the fixed grating and above the water seal in a trapped gully.
2. Downward discharges at a low level; i.e. up to 100mm above external surfaces such as car parks, hard standings, grassed areas etc are acceptable providing that where children play or otherwise come into contact with discharges, a wire cage or similar guard is positioned to prevent contact whilst maintaining visibility.
3. Discharges at a high level; e.g. into metal hopper and metal down pipe with the end of the discharge pipe clearly visible (tundish visible or not) or onto a roof capable of withstanding high temperature discharges of water and 3m from any plastic guttering systems that would collect such discharges.
4. Where a single common discharge pipe serves more than one system, it should be at least one pipe size larger than the largest individual discharge pipe (D2) to be connected.
5. If unvented hot water storage systems are installed where discharges from safety devices may not be apparent i.e. in dwellings occupied by blind, infirm or disabled people, consideration should be given to the installation of an electronically operated device to warn when discharge takes place.

## Safety

The safety devices supplied or fitted on an Thermstore are selected for their suitability for the temperatures and pressures involved. They must not be changed, removed or by-passed and it is essential that only genuine replacement parts supplied or approved by Ideal Boilers are used. All parts are available to approved installers from Ideal Boilers.

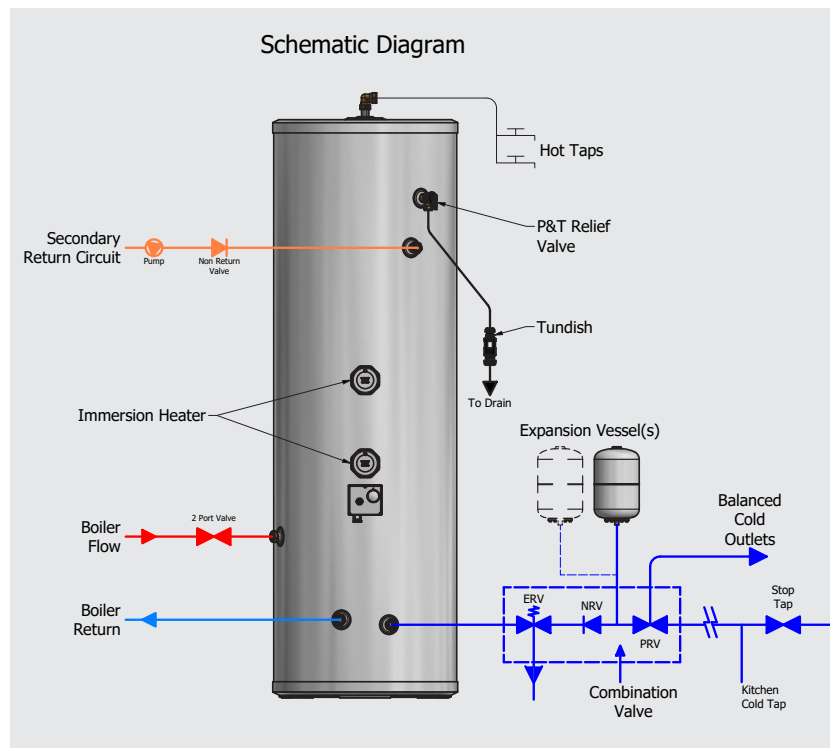

## Line Strainer

This is integral within the combination inlet group to reduce the likelihood of contaminants fouling the valve seat. Following installation this line strainer must be cleaned and replaced. This needs to be carried out on a regular basis, as part of the annual maintenance/service check.

## Tundish

This is to allow the discharge from any Relief Valve to be seen. It must be fitted away from any electrical devices. See page 12 for discharge pipework details.

## Expansion Vessels Installation

To prevent water stagnation and particulate accumulation affecting water quality, it is recommended that the expansion vessel be installed in the vertical orientation so that the fitting accommodating thermal expansion or a pressure surge is:-

1. bottom fed and upright; and
2. that the connecting pipework to the fitting:-
  - rises continuously; and
  - is kept to a minimum;

## 2 expansion vessels on 400 litre Models

All 400 litre models are supplied with two 24 litre expansion vessels. These can be coupled together and fitted to the expansion cylinder tapping on the combination inlet valve, or by some other means on the cold/hot water inlet pipework. There must be no valve on the pipe work between the expansion cylinders and the unvented cylinder which could prevent the expansion of the water contained in the unvented cylinder reaching the expansion cylinders.

## Combination Inlet Group

Combines elements 1, 2 and 3 below.

1. **Pressure Reducing Valve** - The cold water supply to any mixer taps/showers must be taken from the cold water tapping of this valve to ensure balanced hot and cold pressures. This valve is factory set to ensure the correct operating pressure for the Thermstore.
2. **Non Return Valve** - This is integral with the pressure reducing valve to prevent backflow of hot water towards cold water draw off points.
3. **Cold Water Expansion Relief Valve** - This safety device is preset at the factory and will relieve excess cold water pressure resulting from a fault condition.

# INSTALLATION

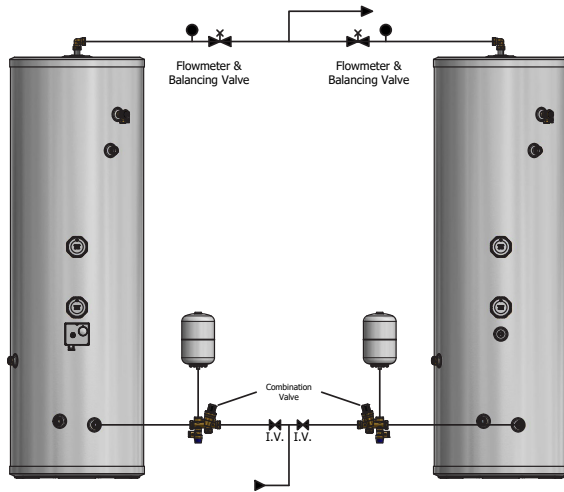

If two Thermstore cylinders are coupled together the secondary inlet and outlet pipes must be balanced. The units must be fitted on the same level.

**Note: No valves must be fitted between the expansion vessel and the storage cylinder(s).**

## Pressure & Temperature Relief Valve

This safety device is also pre-set at the factory and relieves before the temperature reaches 100°C. It is also a Pressure Relief Valve, and is pre-set to 6 bar.

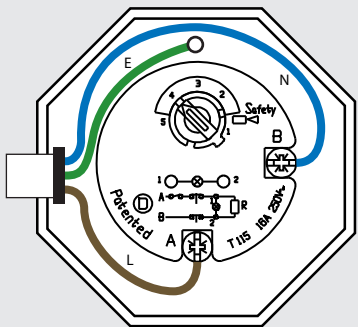

Thermostat Type TSE fitted in the indirect cylinders - is supplied set in position 5 at 60°C ± 4°C.

When ordering a replacement part the TSR thermostat type will be supplied with the immersion heater.

**Immersion Heater Wiring**

## Immersion Heaters

The immersion heaters fitted to our units are 3kW 240V ~AC. Check that the mains supply conforms to this, and all external wiring conforms to the most recent revision of the IEE wiring regulations. An Incoloy element is used on this product for standard domestic use and water conditions, use our Titanium elements in all other circumstances, part number SH002.

The immersion heater is fitted into the hot water cylinder using an O-ring. After the unit is filled with water check for leaks to determine if the O-ring has sealed and tighten carefully using the appropriate tool. To prevent damage to the O ring do not use excessive force to tighten the immersion heater.

The immersion heater is supplied with a thermostat which has been tested for operation in the cylinder and complies with the European directives for Electromagnetic compatibility and radio interference. It is Rated at 16 Amp 250V ~AC.

The immersion thermostat has two terminals A and B. The Live (brown) wire should be connected to terminal A and the Neutral (blue) wire should be connected to terminal B. It has been our experience that Crimp terminals make better connections. The immersion heater must be fully earthed (earth post) and connected via a double pole isolator switch having a contact separation at least 3mm, see diagram opposite.

**Danger of electrocution: before making any adjustments to the thermostat isolate the immersion heater from the mains electricity supply at the fuse spur unit.**

The immersion heater thermostats incorporate a manual reset safety/overheat cut out thermostat. Should this operate, investigate the cause before pressing the red reset button labelled safety. If there is no apparent fault adjust the control setting down slightly to prevent nuisance tripping.

If another heat source is used to heat the cylinder and this is allowed to raise the water temperature excessively then the overheat thermostat will trip. This is likely on solar thermal products when the solar thermostats are set at high temperatures.

The Direct cylinder is intended to be heated from an off peak supply using the lowest immersion heater(s) and boosted via the upper immersion heater from an on peak supply. Suitable controllers are available to control this operation effectively.

## Solar Thermistors / sensors

Care must be taken to ensure that the solar probes are fully inserted into the pockets provided.

## Important

Failure to follow the drain down procedure will invalidate the warranty. (see page 20)

**NEVER** drain the cylinder of hot water and then close all cylinder inlets and outlets.

**REASON** as the air remaining in the cylinder cools the pressure inside the cylinder will fall below atmospheric and cause damage to the cylinder.

**NEVER** close the cold main and drain the cylinder via any tap connected to it.

**REASON** as the water drains, the pressure inside the cylinder may decrease below atmospheric and this may cause damage to the cylinder.

In line with good plumbing practice, use of excessive flux should be avoided.



# INSTALLATION

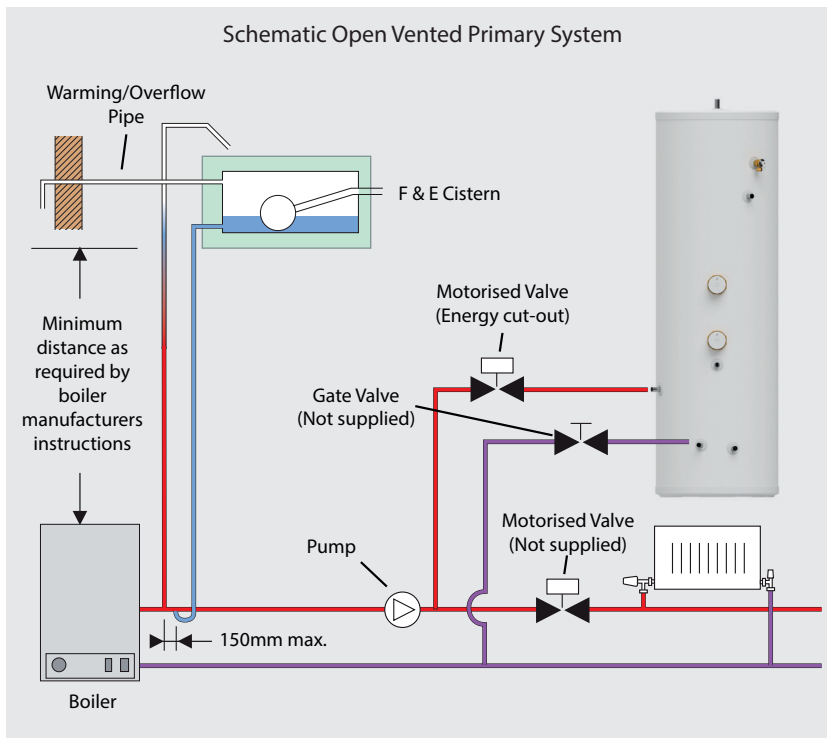

## Heating/primary Systems

The boiler and primary/heating systems should be sized and installed in accordance with BS EN 12828:2003, BS EN 12831:2003 & BS EN 14336:2004.

## Safety

Thermostore is fitted with a Combined Temperature/Pressure Relief Valve to cope with any increase in system temperature and pressure above the design limitations, when used with boilers up to 45kW output, which is the maximum allowed by section G3 of the Building Regulations. The primary water temperatures should be controlled as outlined below.

## Primary Circuit

It is essential that the circuit between the boiler and the Thermostore is pumped. The motorised zone valve supplied should be fitted adjacent to the unit and controlled by the cylinder thermostat supplied. The thermostat and motorised valve must be wired so that they both switch off should an overheat situation develop. When wiring the supplied components, it is important to follow the wiring diagram in the Wiring Section of these instructions.

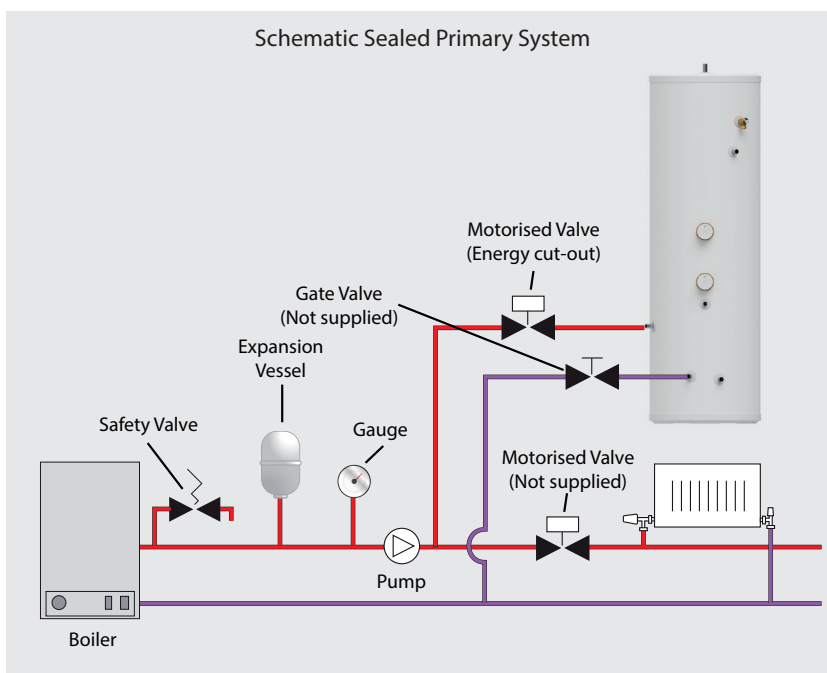

## Sealed Primary Circuit

Any boiler used must be fitted with an over temperature cut-out. Unvented primary circuits may be filled or replenished by means of a temporary connection between the circuit and a supply pipe provided a 'Listed' double check valve or some other no less effective backflow prevention device is permanently connected at the inlet to the circuit and the temporary connection is removed after use.

Alternatively, a CA device can be used, which will allow the system to be permanently connected to the cold mains supply. The primary system can then be topped up, when required, in the same way as an open vented system fitted with an F&E Cistern.

## Gate Valve

All our cylinders are tested to BS EN 12897 at 15 l/min.

In extreme situations where excessive flow rates, above 25 l/min are present, then a gate valve on the return from the cylinder to the boiler, before it joins the central heating return, may be required to reduce excessive flow rates and therefore any potential noise problems.

# INSTALLATION

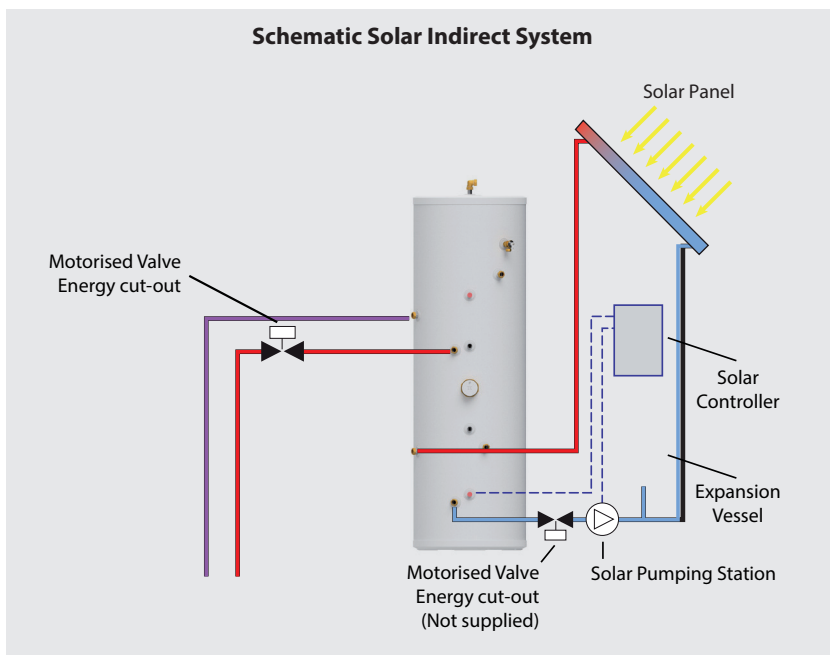

All components in a solar primary system must be marked or identifiable in such a way that their design pressure and temperature can be readily determined.

A pressure relief valve to control the risk of over-pressure in system components should be fitted. A termination from a pressure relief valve should minimise the risk of damage to persons or materials. Suitable locations are into a high temperature receptacle, an internal gully or externally at ground level. High level termination from walls or on roofs could cause injury to people or animals below if the valve were to release scalding water and steam.

The pipe leading to the safety device and the collector should be of rigid and non-deformable construction, without any possibility of restriction or closure by any other fitted component.

A more detailed diagram of our recommended arrangement for a typical solar system is shown on page 18.

This provides all the necessary controls and safety devices necessary for the solar system i.e. the two port zone valve is wired as an energy cut out and the pump/valve will only allow heat transfer as required under control of the solar controller.

The solar pocket provided accommodates an 8mm diameter sensor which, with the sensor located in the solar collector (or in the flow pipe immediately adjacent to the collector), will provide the information required by the solar controller.

**Note: If the motorised valve is not used then any factory built hydraulic station for solar use MUST be fitted with suitable non-return valves in both flow and return pipes to prevent gravity circulation when the pump is not running.**

If there is a possibility of the solar controller that you install causing the cylinder temperature to exceed 80°C, under normal working conditions, then a Solar tempering valve must be fitted to the domestic hot water outlet of the cylinder. This must limit the hot water temperature to a maximum of 60°C.(ref building regulations part G3 3.63). Suitable plumbing configurations for installing this valve are shown on page 17 of this manual. NB. Any fitted Overheat thermostats may require resetting in the winter months to enable backup heat sources to heat the cylinder.



# INSTALLATION

**Figure 1: Cold port of the blending valve connected to mains supply NOT ALLOWED**

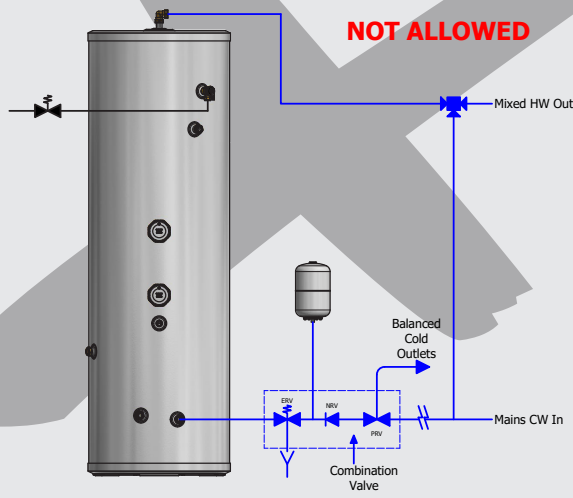

## Fitting Blending Valves To The Unvented Thermstore Appliances

When fitting a blending valve to the unvented appliances, it is important that the installation does not contravene the G3, WRC and Health and Safety directives or the manufacturers recommendations. If this is the case, then the warranty should be null & void. The key requirements to comply with these regulations are: -

1. Any fitting or material in contact with potable water (e.g. a blending valve) must be approved by WRC or an equivalent body.
2. Connections or wiring arrangements must not bypass any safety devices.
3. Any expansion due to heating must not be allowed to expand back into the cold mains.
4. The settings of any safety devices must not be tampered with or adjusted.

**Figure 2: Cold port of the blending valve connected to balanced cold supply - NON-RETURN VALVE MUST BE FITTED**

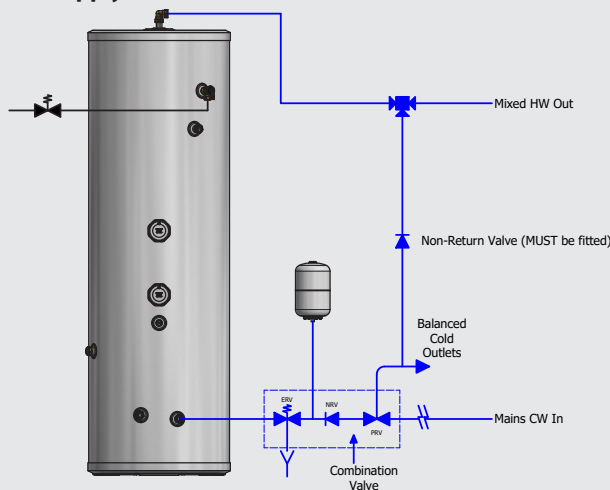

The diagrams opposite shows how the blending valve can be piped onsite.

Figure 1 shows the cold water port of the blending valve connected to the mains cold water supply before the inlet control group. This arrangement is completely unacceptable and illegal because: -

- the water is allowed to expand in to mains cold water supply.
- the vessel will be charged to the incoming mains supply which may be considerably higher than the working pressure of the vessel.

If this arrangement is used then the Ideal Boilers warranty will not be valid.

Figure 2 shows the cold water port of the blending valve connected to the balanced cold water outlet. This arrangement will only be acceptable if a WRAS approved non-return valve is fitted, otherwise: -

- during the heating cycle, the water will expand back into the mains supply, as the regulating valve must not be relied upon to act as a check valve under all operating conditions.
- depending upon the characteristics of the blending valve, hot water may also flow from the balanced cold water taps.

**Figure 3: Cold port of the blending valve connected to mains supply to the vessel after the inlet control group**

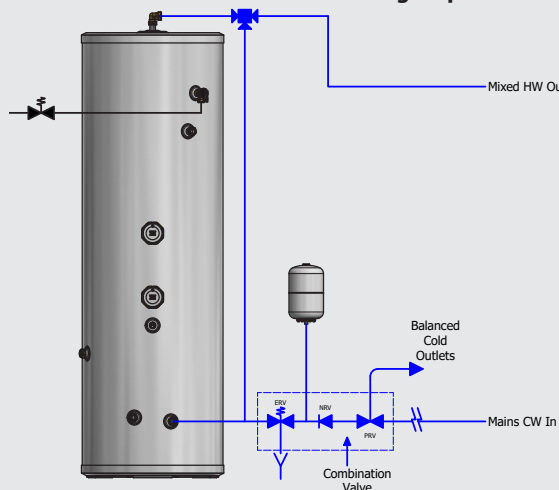
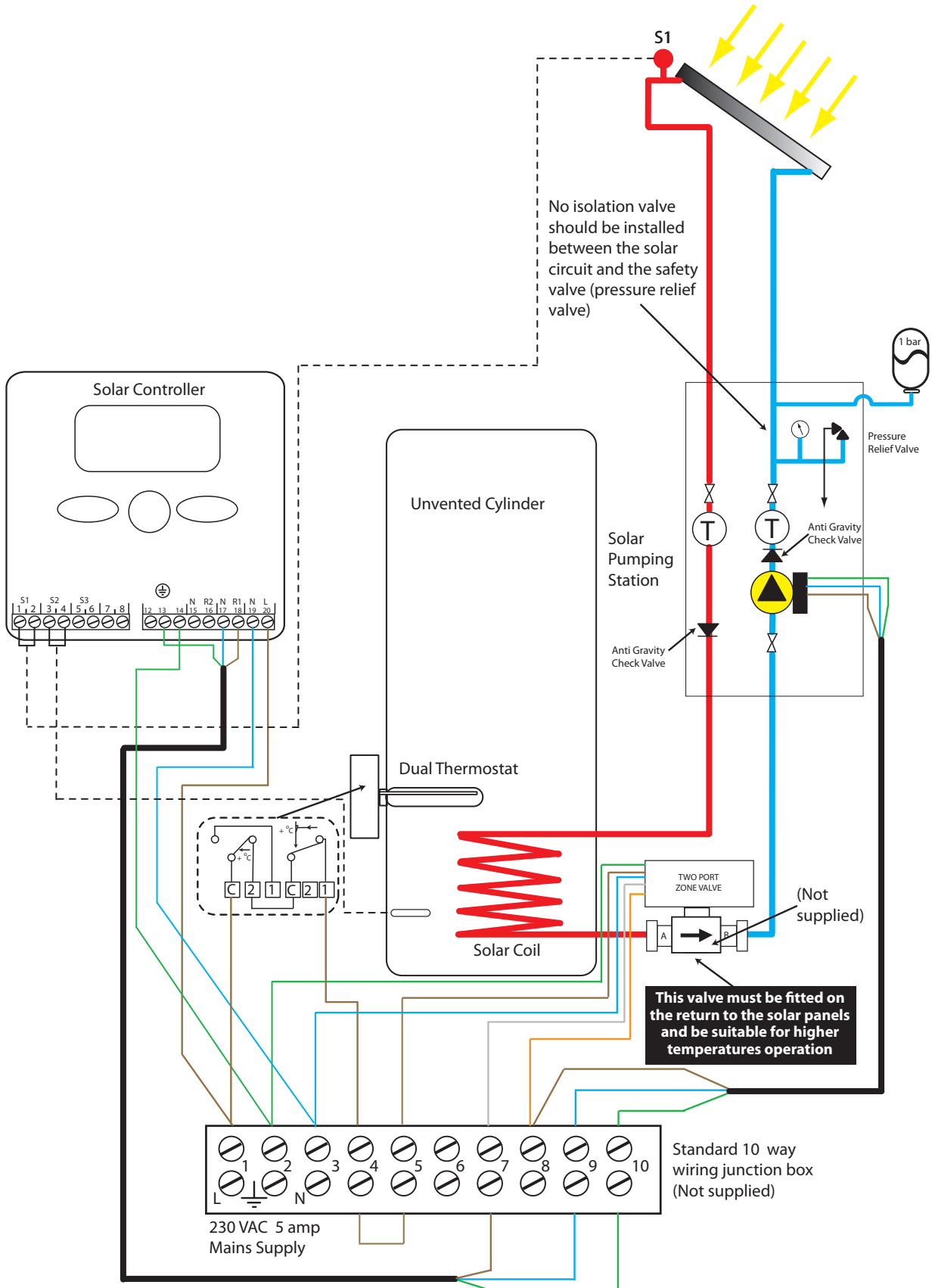

Figure 3 shows the cold port of the blending valve connected to the cold water supply to the vessel after the inlet control group. This should be the preferred method. It is recommended that the installer should ensure that there is no gravity circulation in the pipework connected to the cold port. If necessary, this can be achieved by fitting a non-return valve or using a thermal trap.

# INSTALLATION

Schematic Showing Solar Wiring Requirements



# INSTALLATION

(S-PLAN) WIRING DIAGRAM WITH TWO 2 PORT VALVES

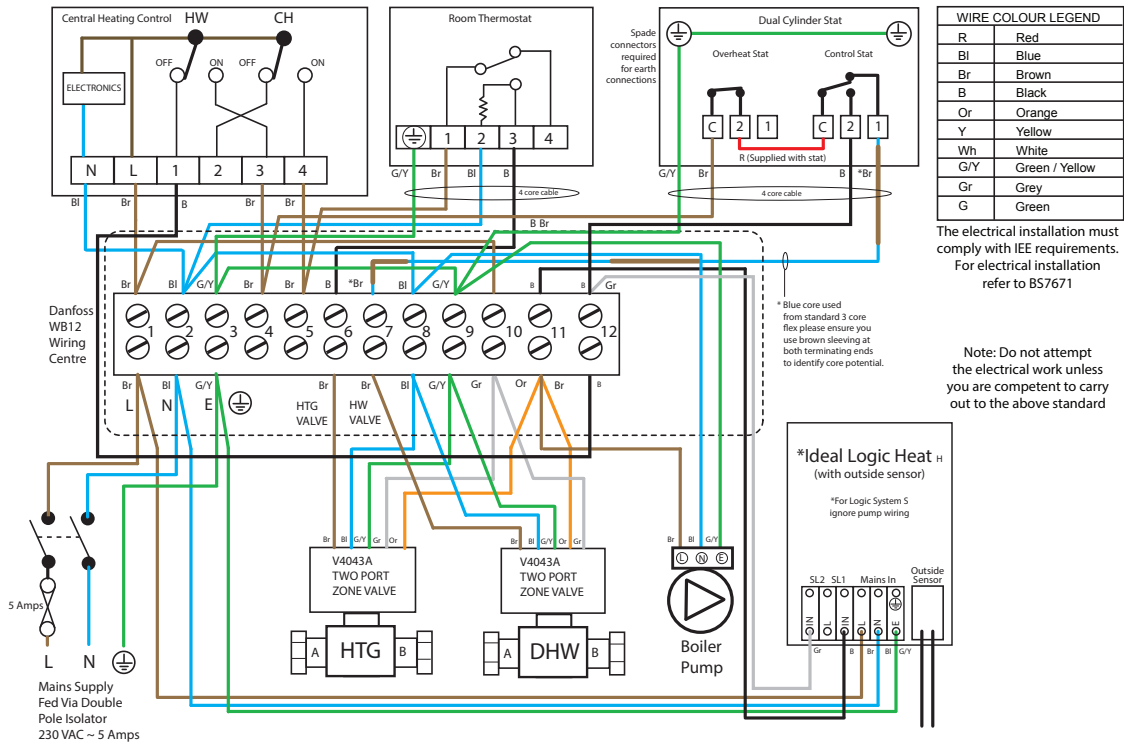

Ideal schematic wiring diagram for an unvented installation

(Y-PLAN) WIRING DIAGRAM WITH 3 PORT VALVE/2 PORT SAFETY VALVE

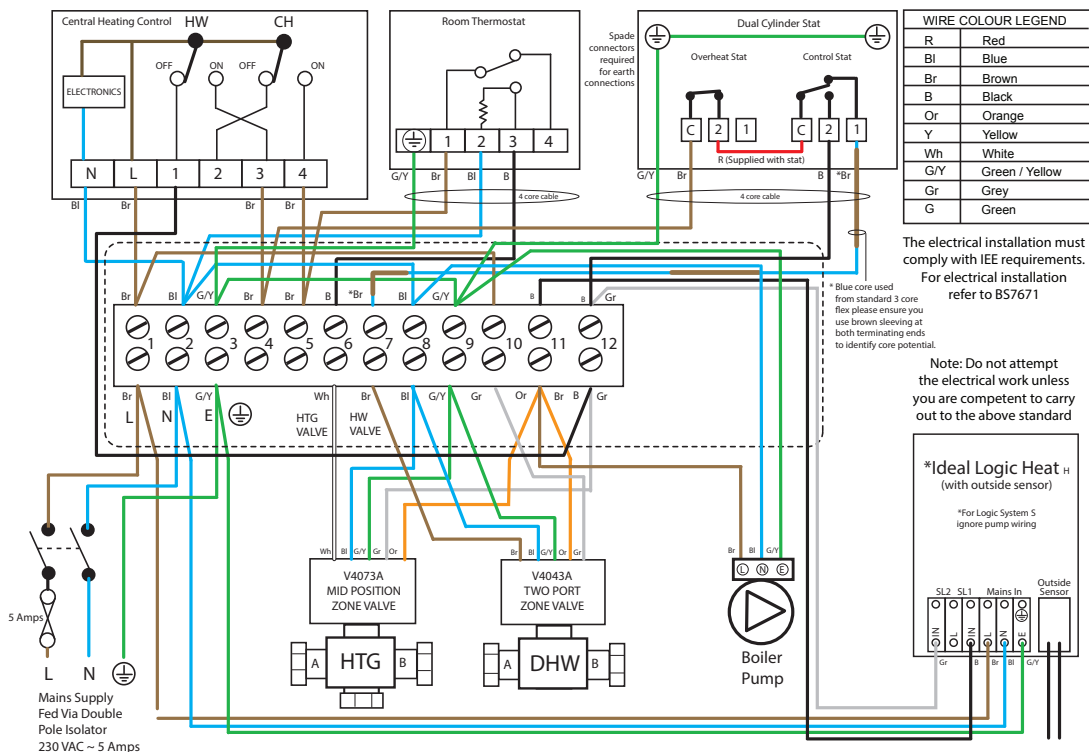

Ideal schematic wiring diagram for an unvented installation

# INSTALLATION

## (S-PLAN) WIRING DIAGRAM WITH TWO 2 PORT VALVES

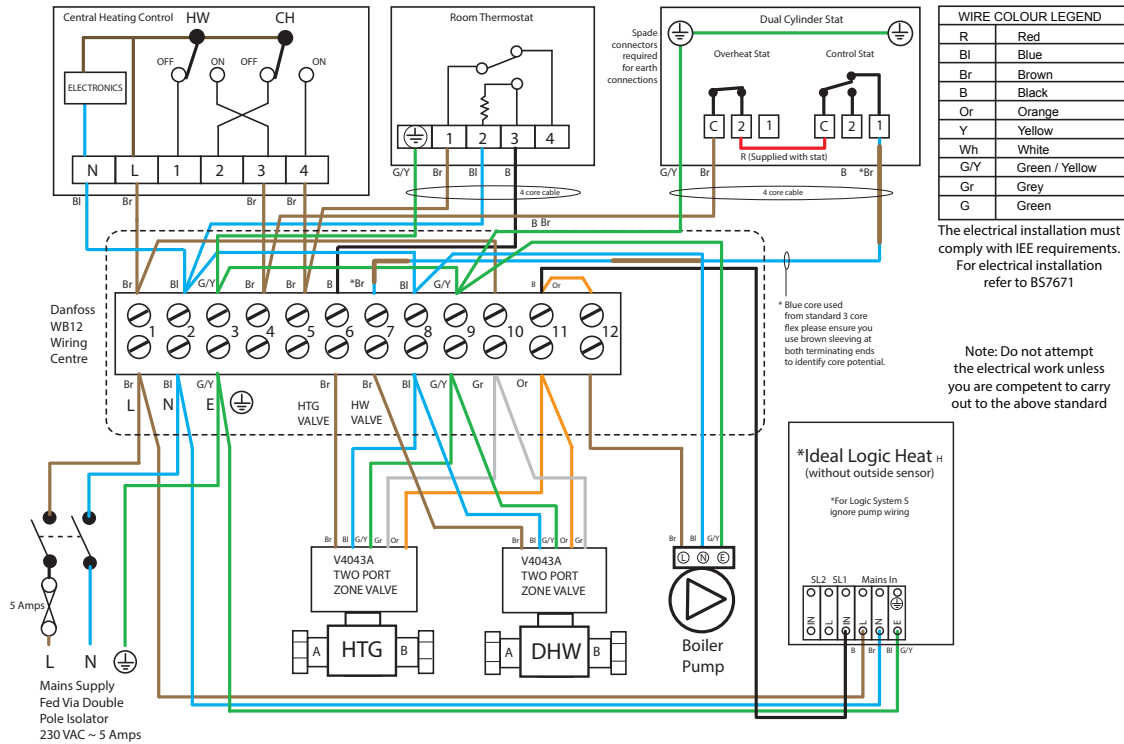

Ideal schematic wiring diagram for an unvented installation

## (Y-PLAN) WIRING DIAGRAM WITH 3 PORT VALVE/2 PORT SAFETY VALVE

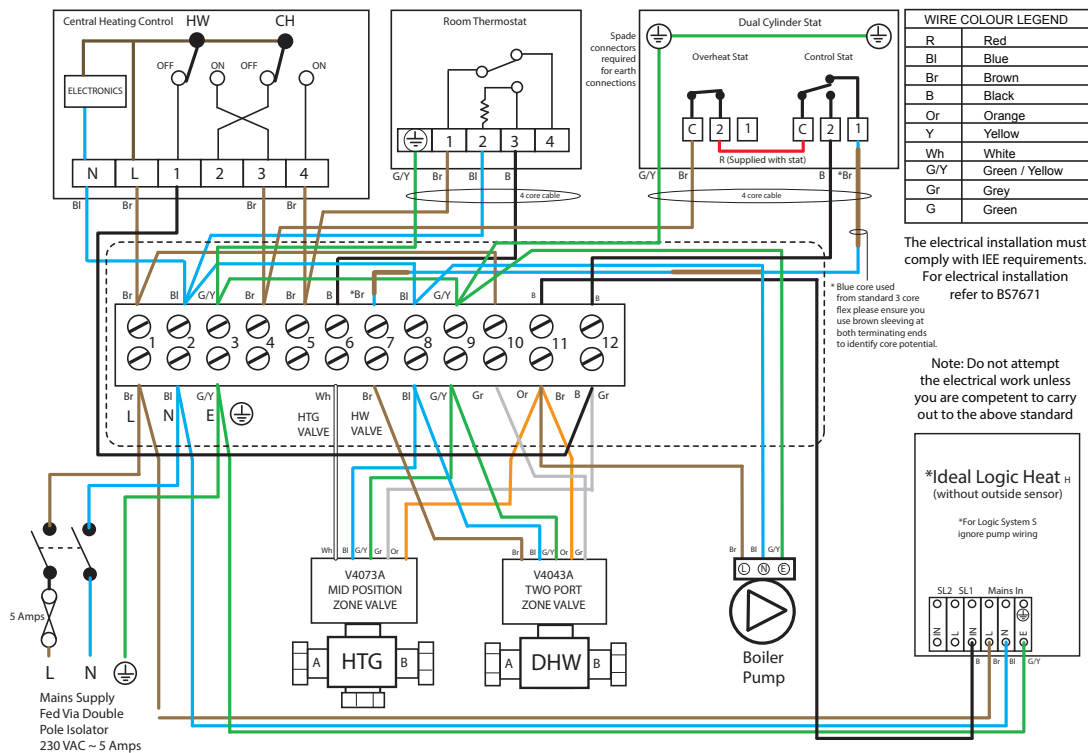

Ideal schematic wiring diagram for an unvented installation

# INSTALLATION

## (S-PLAN) WIRING DIAGRAM WITH TWO 2 PORT VALVES AND BOILER CONTROLLED PUMP OVERRUN OPTION

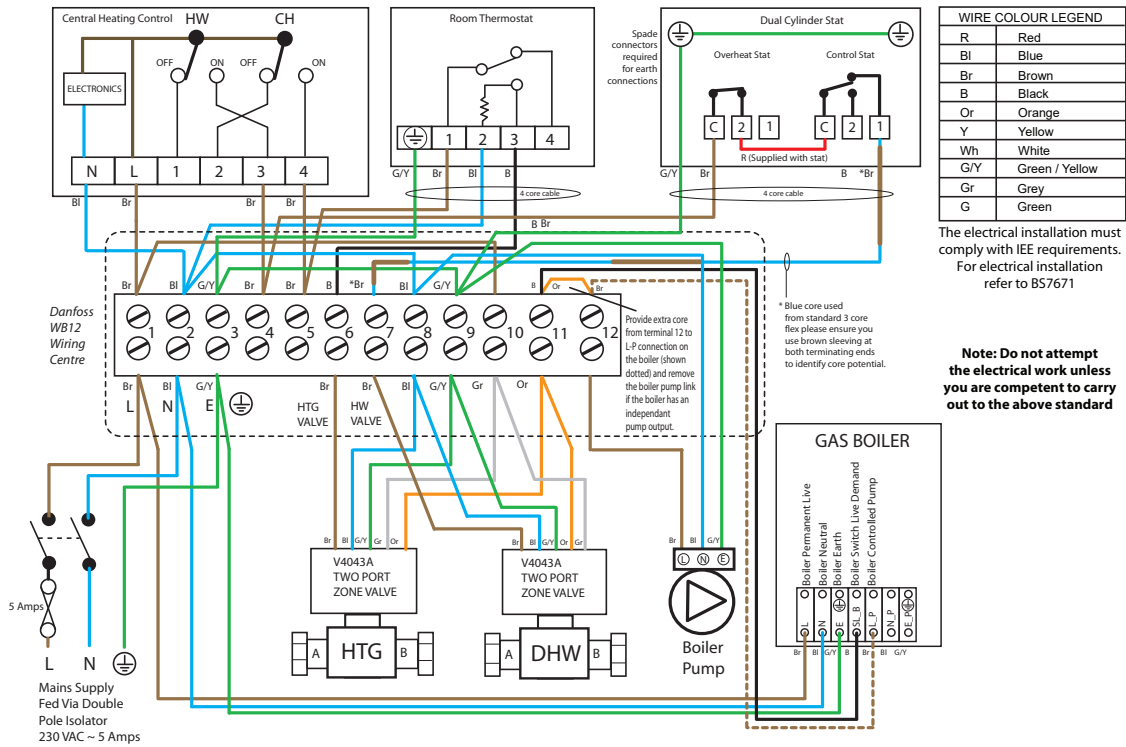

## (Y-PLAN) WIRING DIAGRAM WITH 3 PORT VALVE/2 PORT SAFETY VALVE AND BOILER CONTROLLED PUMP OVERRUN OPTION

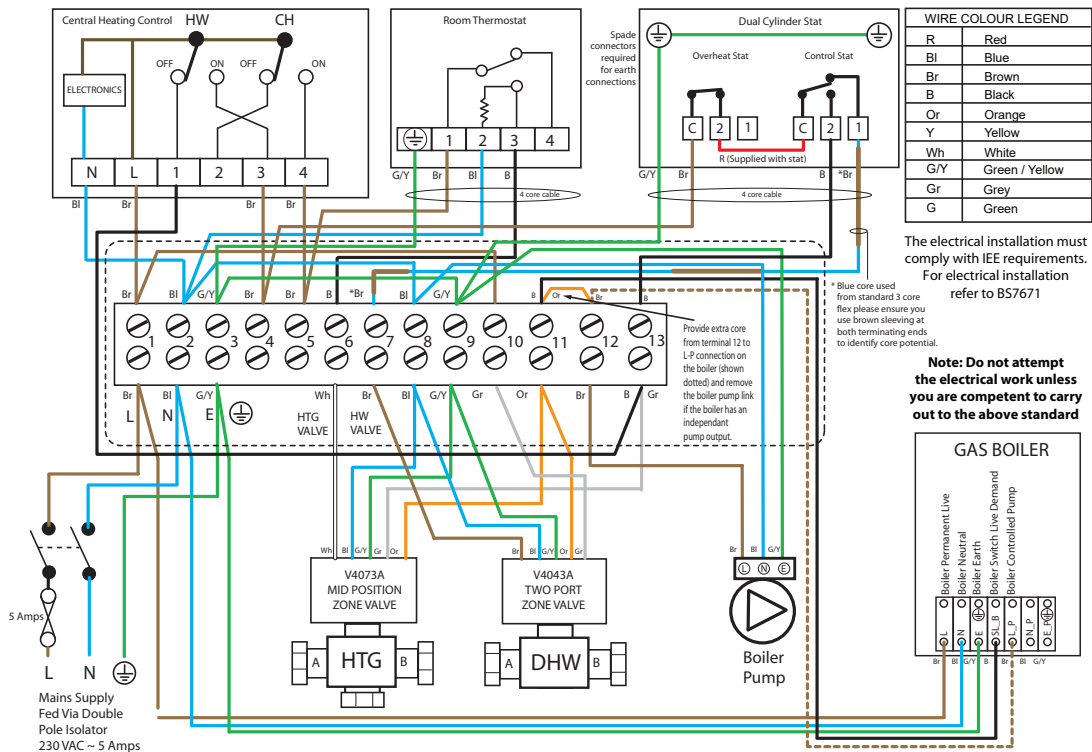

# INSTALLATION

Connections can come loose in transit, and all should be checked before installation.

The 90 degree elbow fitted on the hot draw off needs to be positioned and tightened by installer.

The control thermostat for indirect heat exchanger heat up of our cylinders are usually set at between 60°C - 65°C. During commissioning the actual temperature that the cylinder reaches when the thermostat(s) operate should be tested and adjusted so that it achieves a minimum of 60°C. This temperature needs to be achieved on a regular basis.

Check the pressure on the air side of the expansion vessel = 3 bar. This must be done when the water in the cylinder is free to expand in atmospheric pressure or the cylinder and relevant pipe work is empty.

Check that the drain cock is closed, and open all the cold and hot water taps and other terminal fittings. Allow the system to fill with water, and to run until there is no air left in the system. Close the taps and inspect the system closely for leaks.

Manually open the Relief Valves one by one and check that water is discharged and run freely through the tundish and out at the discharge point. The pipework should accept full bore discharge without overflowing at the tundish, and the valve should seat satisfactorily.

In line with good plumbing practice, use of excessive flux should be avoided. When soldering above the cylinder, ensure flux/solder does not contaminate the cylinder below, since this can cause corrosion. Flushing should be done performed as per BS EN 806:4 2010 section 6.2.

Allow the cylinder to heat to normal working temperature, then thoroughly flush the domestic hot and cold water pipework through each tap.

**NOTE:** If this appliance is to be installed in other than a single domestic dwelling ie. in an apartment block or student flats etc., the hot and cold water system will need to be disinfected in accordance with BS EN 806:4 2010 section 6.3 and the Water Regulations.

Because the Thermstore appliance is stainless steel, the use of chlorine as the disinfection agent can cause damage unless the appliance is adequately flushed and refilled with the mains water immediately on completion of the disinfection procedure.

Damage caused through a failure to do this adequately will not be covered by the warranty.

For the reasons mentioned, we recommend the use of a non chlorine based disinfectant such as Fernox LP Sterox as manufactured by Cookson Electronics when carrying out disinfection of systems incorporating these appliances.

Isolate the cold supply to the cylinder. Remove the inlet control valve. Inspect the gause filter on the inlet side and remove any debris. Refill the system and open all hot taps until there is no air in the pipe work. **ENSURE the cylinder is drained prior to removing the inlet control group.**

Allow the cylinder to heat to normal working temperature with whatever heat source is to be used, and check again for leaks. The pressure relief valve or the P&T valve should not operate during the heating cycle. If the P&T valve operates before the pressure relief valve due to high pressure, check that the inlet control group is fitted correctly, and no valve is between the inlet control group and the cylinder.

The boiler/heating systems should be filled and commissioned in accordance with good practice following the guidance in BS 7593:2006/the boiler manufacturers instructions. This includes adequately flushing the system to remove any debris that may have been introduced during installation/maintenance.

## NOTE

At the time of commissioning, complete all relevant sections of the Benchmark Checklist located on the inside back pages of this document.

This must be completed during commissioning and left with the product to meet the Warranty conditions offered by Ideal Boilers.

## IMPORTANT - DRAIN DOWN PROCEDURE

- 1 Switch off both the boiler and the immersion heater
- 2 Open the nearest hot tap and run all hot water until cold, then close it
- 3 Close the incoming cold main at the stop tap
- 4 **Hold open the pressure and temperature relief valve until water stops discharging into the tundish and leave it open**
- 5 Open the cold taps starting from the highest point and working down to the lowest tap, leaving them open
- 6 When the cold taps have stopped draining, open the hot taps starting from the highest and working down to the lowest tap
- 7 Open the drain cock and ensure the pressure and temperature relief valve is held open until the cylinder is empty

# SERVICING AND MAINTENANCE

The Registered Installer is responsible for the safe installation and operation of the system. The installer must also make his customer aware that periodic maintenance of the equipment is essential for safety.

Maintenance periods will vary for many reasons. Ideal Boilers recommend a maximum of 12 months to coincide with boiler maintenance. Experience of local water conditions may indicate that more frequent maintenance is desirable, eg, when water is particularly hard, scale-forming or where the water supply contains a high proportion of solids, eg, sand. Maintenance must include the following:

1. Isolate the cold supply to the cylinder. Remove the inlet control valve. Inspect the gauge filter on the inlet side and remove any debris.
2. Manually check the operation of the temperature relief valve.
3. Manually check the operation of the expansion relief valve.
4. Check discharge pipes from temperature and expansion relief valves are free from obstruction and blockage and are not passing any water.
5. Check the condition and if necessary descale the heat exchangers in hard water areas.
6. Check that water pressure downstream of pressure reducing valve is within the manufacturers limits.
7. Check operation of motorised valve.
8. Check the pressure on the air side of the expansion vessel. This must be done with the pressure on the water side at zero (gauge pressure).
9. Check and advise the householder not to place any clothing or other combustible materials against or on top of this appliance.
10. On completion of the work, fill in the Benchmark Service Record towards the back of this manual.

## IMPORTANT NOTE

**When draining down the appliance for any reason, the instructions provided in the Commissioning Section (Page 20) MUST be followed to prevent potential damage to the cylinder.**

After servicing, complete the relevant Service Interval Record section of the Benchmark Checklist located inside this document.

# SERVICING AND MAINTENANCE

## Scale

In hard water areas it is recommended that an in-line scale inhibitor is fitted. Reducing the temperature of the stored water will reduce the rate at which scale forms. If the recovery rate is badly affected, this is an indication that scaling may have occurred. In this event, follow the procedures as recommended by a reputable Water Treatment Company.

## General

No water at the tap. Check that the mains water supply is turned ON. Check the line strainer is not blocked. Check that the combination valve has been fitted so that water is flowing in the correct direction.

If the water at the tap is cold, ensure that the boiler has been switched ON and is working correctly. Check that there are no air locks in the primary system. ISOLATE THE UNIT AT THE MAINS ELECTRIC SUPPLY AND THEN CHECK THE FOLLOWING:

- i. The cylinder thermostat
- ii. The thermal cut-out, which can be re-set by pushing the red button
- iii. The motorised valve
- iv. The boiler thermostat
- v. The boiler thermostat cut-out (if fitted)

ANY ENERGY CUT-OUT MUST NEVER BE BY-PASSED UNDER ANY CIRCUMSTANCES.

If the units are not getting hot and the heat source is electrical, ensure that the immersion heaters are isolated from the mains before re-setting the energy cut-out. If the immersion heater(s) need replacing this should be done with the units supplied from Ideal Boilers.

## Discharge From Relief Valves

If cold water is discharging from the expansion relief valve into the tundish check the pressure on the expansion vessel when cold and recharge if necessary.

If the fault continues and the problem cannot be stopped by operating the easing control a few times then either the Pressure Reducing Valve or the Relief Valve may be at fault. If the cold water pressure is too high, this would suggest that the Pressure Reducing Valve is at fault and the Ideal Boilers approved replacement should be fitted. If the pressure is correct then the Relief Valve will require replacing with a Ideal Boilers approved component.

## See Commissioning for drain down procedure.

If there is an overheat fault and very hot water is being discharged, turn off the heat source, **but not the water supply.**

When the supply is cool, check thermostats and energy cut-outs in the boiler and immersion heaters and replace the faulty component with one supplied by Ideal Boilers and check that it works correctly before returning the system to full operation.



# SERVICING AND MAINTENANCE

## FAULT - No Hot Water (Indirect)

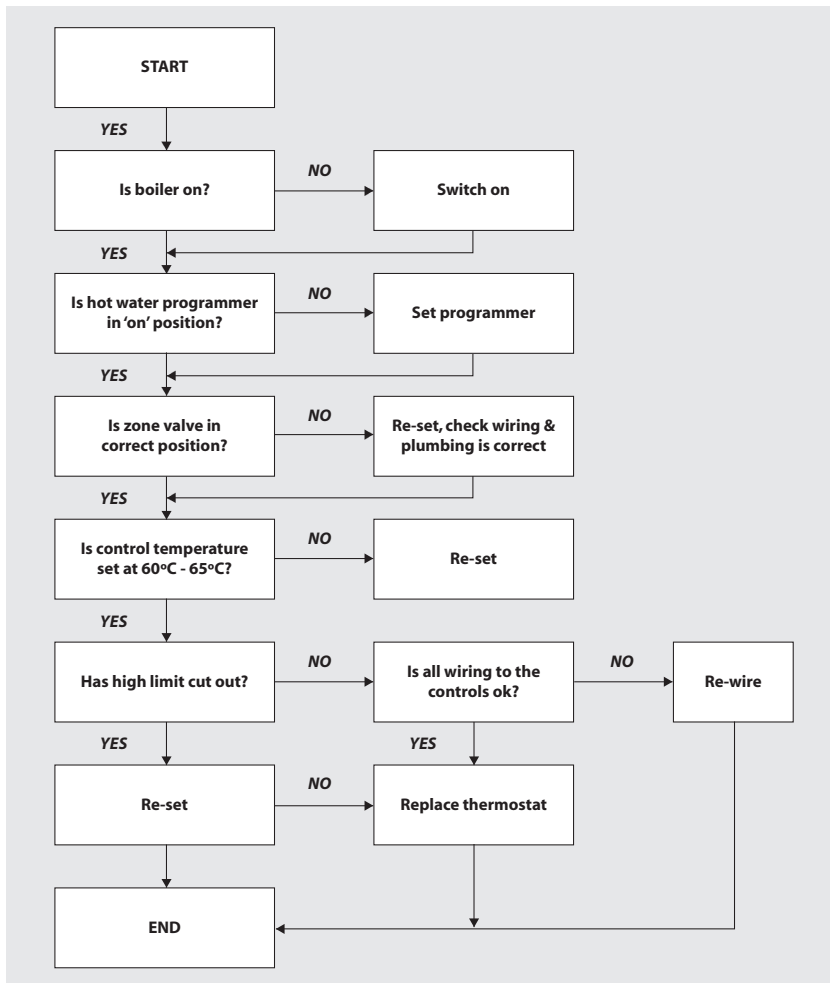

# SERVICING AND MAINTENANCE

**FAULT - Poor Water Flow at Hot Taps**

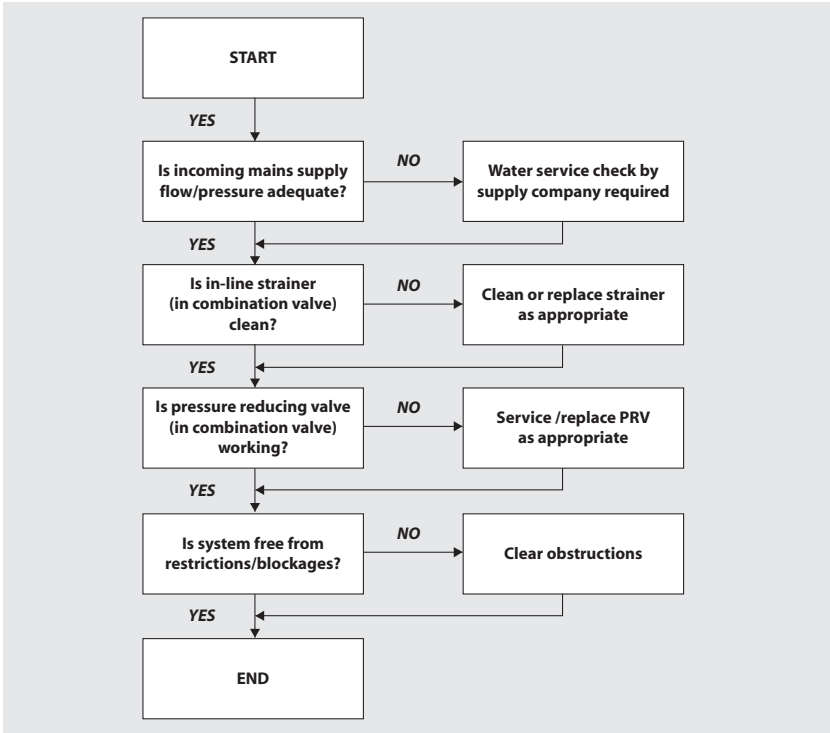

**FAULT - Water Discharge Into Tundish**

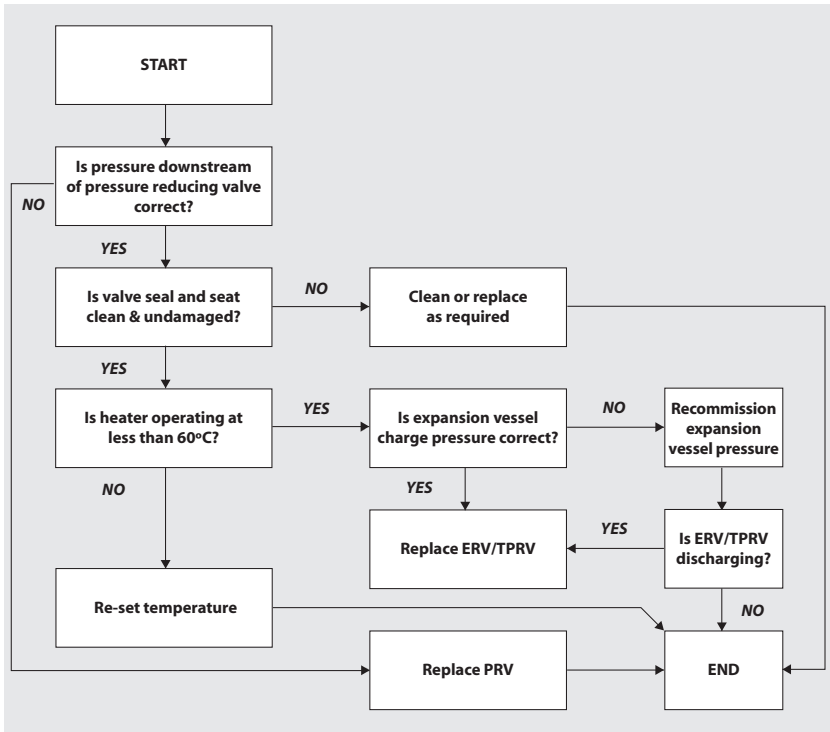

# SERVICING AND MAINTENANCE

SPARE PARTS LIST			
	Description	Quantity	Stock Code No.
1	3kW Immersion element	1	176749
2	22mm 90° Compression elbow	1	184057
3	Pressure and temperature relief valve 6 bar 92-95° bar	1	176748
4	Inlet group set at 3 bar c/w expansion relief valve set at 4.5 bar	1	176750
5	12 litre expansion vessel	1	176751
6	19 litre expansion vessel	1	176752
7	24 litre expansion vessel	1	176753
8	35 litre expansion vessel	1	176754
9	22mm 2 Port valve (Indirects only)	1	176758
10	Control and overheat limit thermostat	1	176757
11	15mm x 22mm tundish	1	176756

# APPENDIX

## MANUAL HANDLING OF APPLIANCE PRODUCTS

### Description

Manual handling means any transporting or supporting of a load (including lifting, putting down, pushing, pulling, carrying or moving) by hand or bodily force.

### Scope

This assessment will cover the largest unit within each product range.

For specific weights and dimensions please refer to technical data section.

### Main Hazards

Vision may not be clear due to the size of the products.

Adopting an incorrect method of lifting may cause injury, attempting to lift these products will require help from others. (Team lifts)

### Control Measures

#### Manual lifting procedure

The lift, key factors in safe lifting are:

- a. **Balance**
- b. **Position of back**
- c. **Positioning of the arms and body**
- d. **The hold**
- e. **Taking the lead for team lifts**

a. **Balance** - Since balance depends essentially upon the position of the feet, they should be apart about hip breadth with one foot advanced giving full balance sideways and forward without tension. In taking up this position, lifting is done by bending at the knees instead of the hips and the muscles that are brought into use are those of the thigh and not the back.

b. **Position of back** - Straight - not necessary vertical. The spine must be kept rigid, this coupled with a bent knee position, allows the centre line of gravity of the body to be over the weight so reducing strain.

c. **Positioning of arms and body** - The further arms are away from the side, the greater the strain on the shoulders, chest and back. Keep elbows close to the body arms should be straight.

d. **The hold** - Before lifting ensure you have a good hold.

- e. **Taking the lead for team lifts**- As more than one person is required for these products ensure that one person is taking the lead. **This may be you** so ensure that each person that is helping is made aware of the weight and of the items listed within this assessment. Make sure you and any others helping know the route you intend to take that it is clear of any obstructions. Never jerk the load as this will add a little extra force and can cause severe strain to the arms, back and shoulders. If there are steps involved decide on where you will stop and take a rest period. Move smoothly and in unison taking care to look and listen to others helping with the lift. Where possible use a sack truck to move the product over long flat distances, only lift the products when necessary. If in doubt stop and get more help.

#### Individual capability

Individual capability plays an important part in handling these products. Persons above average build and strength will find it easier and should be in good health. Persons below average build and strength may require more rest periods during the handling process.

Pregnant women should not carry out this operation.

Persons who are not in good health should seek medical advice prior to commencing any lifting or manual handling operation.

#### Residual risk

Following the guidelines given above will reduce any risk to injury.

All persons carrying out this operation must be fully trained and copies of the specific risk assessment made available for inspection and use in their training process.

Further guidance on Manual Handling can be obtained from the Health and Safety Executive. Manual Handling Operations Regulations 1992 (amended by Health and Safety (Miscellaneous Amendments) Regulations 2002.

# TERMS AND CONDITIONS

## Ideal Unvented Cylinder Warranty Terms and Conditions

Ideal Boilers Limited provides a 2 year parts and labour warranty on the cylinder solution provided, the inner cylinder skin is further covered for on a replacement basis beyond this period to 25 years from the date of purchase, subject to adherence with the following terms and conditions of warranty

1. The unit has been installed and commissioned in accordance with our installation and service instructions and all relevant codes of practice and regulations in force at the time of installation.
2. All necessary inlet controls and safety valves have been fitted correctly.
3. The unit has only been used for the storage of potable water supplied from the public mains. The water quality shall be in accordance with European Council Directive 98/83 EC, or revised version at the date of installation, and is not fed with water from a private supply. Particular:
  4. Chloride content: Max. 200 mg/l
  5. Sulphate content: Max. 200 mg/l
  6. Combination chloride/sulphate: Max. 300 mg/l (in total)
5. If the newly fitted water heater is not in regular use then it must be flushed through with fresh water for at least 15 minutes. Open at least one hot water tap once per week, during a period of at least 4 weeks.
6. The Cylinder is registered within 30 days of installation, this can be done by calling Ideal Boilers on **01482 498660**
7. The unit has been regularly maintained as detailed in the installation and service instructions
8. If the Cylinder suffers a mechanical breakdown, calls must be raised with Ideal Boilers Customer Services on **01482 498660**  
Our normal working times, excluding Bank Holidays are:  
8am – 6pm Monday to Friday, 8am – 4pm Saturday,  
8.00am – 12 noon Sunday
9. The guarantee for the stainless steel vessel is for twenty five years against material defect or manufacturing faults if the original unit is returned to us AND PROVIDED THAT:
  - (i) It has not been modified, other than by Ideal.
  - (ii) It has not been subjected to wrong or improper use or left uncared for.
  - (iii) It has only been used for the storage of potable water supplied from the public mains, max 200mg/litre chloride.
  - (iv) It has not been subjected to frost damage.
  - (v) The benchmark service record is completed after each annual service.
  - (vi) The unit has been serviced annually
10. If the stainless steel vessel proves to be defective either in materials or workmanship we reserve the right to either repair or supply replacements or the closest possible substitute in the case of any obsolete product and will collect and deliver to any address in England, Scotland and Wales (excluding all islands):  
Our normal working times, excluding Bank Holidays are:  
8am – 6pm Monday to Friday, 8am – 4pm Saturday,  
8.00am – 12 noon Sunday  
Please note:
  - a. Engineers will only attend to Ideal products where it is considered by the engineer that the installation does not pose a risk to health and safety.
  - b. A permanently fixed access ladder must service installations in lofts or attics. Adequate lighting and permanently fixed flooring must also be available.
  - c. Compartment installations must provide minimum working clearances as detailed in the installation instructions. Ideal will not accept responsibility for the removal of fixtures or fittings in order to gain access for repairs.
11. The guarantee does not apply:
  - a. If the Cylinder is removed from its place of installation without our prior consent.
  - b. To any defect, damage or breakdown caused by inadequate servicing of the cylinder or by deliberate action, accident, misuse or third party interference including modification or an attempted repair which does not fully comply with industry standards.
  - c. To any defect, damage or breakdown caused by the design, installation and maintenance of the central heating system.
  - d. To de-scaling or other work required as a result of hard water scale deposits or from damage caused by aggressive water or sludge resulting from corrosion.
  - e. If the claim/contact procedure set out in section 12 is not adhered to
  - f. To any other costs or expenses caused by or arising as a result of the breakdown of an Ideal Cylinder.
  - g. To any defect resulting from the incorrect installation of the cylinder.
  - h. To any costs incurred during delays in fixing reported faults.
12. We reserve the right to charge a call-out fee where:
  - a. A fault cannot be found.
  - b. The breakdown or fault has been caused by an event, which is excluded from the guarantee – refer to section 11
  - c. Failure to cancel an agreed appointment prior to our engineers visit
  - d. The Cylinder is outside the period of guarantee or the conditions of the guarantee have not been met.
13. If we fit replacement parts or replace a cylinder it will not extend the period of the warranty. All replaced parts or cylinders will become the property of Ideal Boilers Ltd.
14. The warranty applies only where an Ideal cylinder has been installed in a domestic dwelling in mainland United Kingdom, Northern Ireland and I.O.W. to provide hot water.

Our Ideal Warranty is offered in addition to the rights provided to a consumer by law. Details of these rights can be obtained from a Trading Standards Authority or a Citizen Advice Bureau. Guarantor – Ideal Boilers Ltd, P.O. Box 103, National Avenue, Hull, HU5 4JN.

# MAINS PRESSURE HOT WATER STORAGE SYSTEM COMMISSIONING CHECKLIST

This Commissioning Checklist is to be completed in full by the competent person who commissioned the storage system as a means of demonstrating compliance with the appropriate Building Regulations and then handed to the customer to keep for future reference.

Failure to install and commission this equipment to the manufacturer's instructions may invalidate the warranty but does not affect statutory rights.

Customer name:		Telephone number:	
Address:			
Cylinder Make and Model			
Cylinder Serial Number			
Commissioned by (PRINT NAME):		Registered Operative ID Number	
Company name:		Telephone number:	
Company address:			
		Commissioning date:	
To be completed by the customer on receipt of a Building Regulations Compliance Certificate*:			
Building Regulations Notification Number (if applicable)			
<b>ALL SYSTEMS PRIMARY SETTINGS</b> (indirect heating only)			
Is the primary circuit a sealed or open vented system?		Sealed	Open
What is the maximum primary flow temperature?			°C
<b>ALL SYSTEMS</b>			
What is the incoming static cold water pressure at the inlet to the system?			bar
Has a strainer been cleaned of installation debris (if fitted)?		Yes	No
Is the installation in a hard water area (above 200ppm)?		Yes	No
If yes, has a water scale reducer been fitted?		Yes	No
What type of scale reducer has been fitted?			
What is the hot water thermostat set temperature?			°C
What is the maximum hot water flow rate at set thermostat temperature (measured at high flow outlet)?			l/min
Time and temperature controls have been fitted in compliance with Part L of the Building Regulations?			Yes
Type of control system (if applicable)		Y Plan	S Plan Other
Is the cylinder solar (or other renewable) compatible?		Yes	No
What is the hot water temperature at the nearest outlet?			°C
All appropriate pipes have been insulated up to 1 metre or the point where they become concealed			Yes
<b>UNVENTED SYSTEMS ONLY</b>			
Where is the pressure reducing valve situated (if fitted)?			
What is the pressure reducing valve setting?			bar
Has a combined temperature and pressure relief valve and expansion valve been fitted and discharge tested?		Yes	No
The tundish and discharge pipework have been connected and terminated to Part G of the Building Regulations			Yes
Are all energy sources fitted with a cut out device?		Yes	No
Has the expansion vessel or internal air space been checked?		Yes	No
<b>THERMAL STORES ONLY</b>			
What store temperature is achievable?			°C
What is the maximum hot water temperature?			°C
<b>ALL INSTALLATIONS</b>			
The hot water system complies with the appropriate Building Regulations			Yes
The system has been installed and commissioned in accordance with the manufacturer's instructions			Yes
The system controls have been demonstrated to and understood by the customer			Yes
The manufacturer's literature, including Benchmark Checklist and Service Record, has been explained and left with the customer			Yes
Commissioning Engineer's Signature			
Customer's Signature			
(To confirm satisfactory demonstration and receipt of manufacturer's literature)			

\*All installations in England and Wales must be notified to Local Authority Building Control (LABC) either directly or through a Competent Persons Scheme. A Building Regulations Compliance Certificate will then be issued to the customer.



While this Checklist can be used for any installation covered by its description, only appliances manufactured by Scheme Members will be covered by the rules and requirements of the Benchmark Scheme.

**SERVICE RECORD**

It is recommended that your hot water system is serviced regularly and that the appropriate Service Record is completed.

**Service Provider**

Before completing the appropriate Service Record below, please ensure you have carried out the service as described in the manufacturer's instructions.

<b>SERVICE 01</b>		Date:	<b>SERVICE 02</b>		Date:
Engineer name:		Engineer name:		Engineer name:	
Company name:		Company name:		Company name:	
Telephone No:		Telephone No:		Telephone No:	
Comments:		Comments:		Comments:	
.....		.....		.....	
.....		.....		.....	
.....		.....		.....	
.....		.....		.....	
Signature		Signature		Signature	
<b>SERVICE 03</b>		Date:	<b>SERVICE 04</b>		Date:
Engineer name:		Engineer name:		Engineer name:	
Company name:		Company name:		Company name:	
Telephone No:		Telephone No:		Telephone No:	
Comments:		Comments:		Comments:	
.....		.....		.....	
.....		.....		.....	
.....		.....		.....	
.....		.....		.....	
Signature		Signature		Signature	
<b>SERVICE 05</b>		Date:	<b>SERVICE 06</b>		Date:
Engineer name:		Engineer name:		Engineer name:	
Company name:		Company name:		Company name:	
Telephone No:		Telephone No:		Telephone No:	
Comments:		Comments:		Comments:	
.....		.....		.....	
.....		.....		.....	
.....		.....		.....	
.....		.....		.....	
Signature		Signature		Signature	
<b>SERVICE 07</b>		Date:	<b>SERVICE 08</b>		Date:
Engineer name:		Engineer name:		Engineer name:	
Company name:		Company name:		Company name:	
Telephone No:		Telephone No:		Telephone No:	
Comments:		Comments:		Comments:	
.....		.....		.....	
.....		.....		.....	
.....		.....		.....	
.....		.....		.....	
Signature		Signature		Signature	
<b>SERVICE 09</b>		Date:	<b>SERVICE 10</b>		Date:
Engineer name:		Engineer name:		Engineer name:	
Company name:		Company name:		Company name:	
Telephone No:		Telephone No:		Telephone No:	
Comments:		Comments:		Comments:	
.....		.....		.....	
.....		.....		.....	
.....		.....		.....	
.....		.....		.....	
Signature		Signature		Signature	



**WEEE DIRECTIVE 2012/19/EU**  
**Waste Electrical and Electronic Equipment Directive**

- At the end of the product life, dispose of the packaging and product in a corresponding recycle centre.
- Do not dispose of the unit with the usual domestic refuse.
- Do not burn the product.
- Remove the batteries.
- Dispose of the batteries according to the local statutory requirements and not with the usual domestic refuse.



At Ideal Heating we take our environmental impact seriously, therefore when installing any Ideal Heating product please make sure to dispose of any previous appliance in an environmentally conscious manner. Households can contact their local authority to find out how. See <https://www.gov.uk/managing-your-waste-an-overview> for guidance on how to efficiently recycle your business waste.

### Technical Training

Our Expert Academy offer a range of training options designed and delivered by our experts in heating. For details please contact: [expert-academy.co.uk](http://expert-academy.co.uk)

Ideal Boilers Ltd., pursues a policy of continuing improvement in the design and performance of its products. The right is therefore reserved to vary specification without notice.

Ideal is a trademark of Ideal Boilers.

Registered Office

Ideal Boilers Ltd., National Avenue, Hull, East Yorkshire, HU5 4JB

Tel 01482 492251 Fax 01482 448858

Registration No. London 322 137

EU Authorised Representative:

Atlantic SFDT

44 Boulevard des Etats-Unis, 85 000 La Roche-Sur-Yon, France

+33 (0)2 51 44 34 34

Ideal Commercial Technical Helpline: 01482 498376

Ideal Parts: 01482 498665

[idealheating.com](http://idealheating.com)

**ideal**  
HEATING





Your Thermostore unvented cylinder is automatic in normal use, but requires routine maintenance which is normally carried out at least annually along with the boiler service. The maintenance must be carried out by a suitably competent tradesperson who is qualified to work on unvented cylinders. The checks/work needed are listed in the maintenance part of these instructions.

The control thermostat for indirect heat exchanger heat up of our cylinders are usually set at between 60°C - 65°C. During commissioning the actual temperature that the cylinder reaches when the thermostat(s) operate should be tested and adjusted so that it achieves a minimum of 60°C, in order to comply with the Legionella pasteurisation requirements.

When initially opening the taps, a small surge in flow may be experienced, which disappears as the pressure in the system stabilises. This is quite normal with these types of systems and does not indicate a fault.

In some areas the water will initially appear cloudy, but will quickly clear when left to stand. This is nothing to be concerned about and is due to aeration of the water.

**WARNING** - If water is seen flowing through the tundish, this indicates a fault condition which needs action.

If the discharge is hot and continuous, turn the boiler and/or the immersion heaters off, but do not turn off the cold water to the appliance until the discharge is cold. **Note:** The discharge may stop by itself as the discharge cools.

If the discharge is cold and intermittent, no immediate action is needed but this indicates a problem with the expansion vessel.

**However, in both cases you must call the registered installer / a suitably qualified, competent tradesperson, advise them that you have an unvented cylinder and request a maintenance visit.**

**DO NOT**, at any time, tamper in any way with the safety valves or overheating thermostats/wiring.



**THERMSTORE &  
SOLAR THERMSTORE**



When replacing any part on this appliance, use only spare parts that you can be assured conform to the safety and performance specification that we require. Do not use reconditioned or copy parts that have not been clearly authorised by Ideal Heating. For the very latest copy of literature for specification and maintenance practices visit our website [idealheating.com](http://idealheating.com) where you can download the relevant information in PDF format.

# USER GUIDE

## THERMSTORE & SOLAR THERMSTORE

