

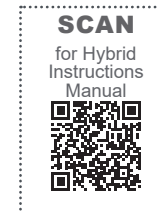

SCHEMATICS

HP290 MONOBLOC HEAT PUMP SYSTEM



When replacing any part on this appliance, use only spare parts that you can be assured conform to the safety and performance specification that we require. Do not use reconditioned or copy parts that have not been clearly authorised by Ideal Heating.

For the very latest copy of literature for specification and maintenance practices visit our website idealheating.com where you can download the relevant information in PDF format.





**WEEE DIRECTIVE 2012/19/EU
Waste Electrical and Electronic Equipment Directive**

- At the end of the product life, dispose of the packaging and product in a corresponding recycle centre.
- Do not dispose of the unit with the usual domestic refuse.
- Do not burn the product.
- Remove the batteries.
- Dispose of the batteries according to the local statutory requirements and not with the usual domestic refuse.



The code of practice for the installation,
commissioning & servicing of central
heating systems



Ideal Heating reserve the right to vary specification without notice

CONTENTS

Figure 1. Schematics Key/Legend	4
Figure 2. HP290 + Single Zone Pre-plumbed Cylinder with Integrated Buffer	5
Figure 3. HP290 + Two Zone Pre-Plumbed Cylinder with Integrated Buffer	6
Figure 4. HP290 + Single Zone Pre-Plumbed Cylinder.....	7
Figure 5. HP290 + Standard Non Pre-Plumbed Heat Pump Cylinder + Buffer with Single Zone	8
Figure 6. HP290 + Standard Non Pre-Plumbed Heat Pump Cylinder + Buffer with Two Zones	9
Figure 7. HP290 + Two Zone Pre-Plumbed Cylinder with Integrated Low Loss Header.....	10
Figure 8. HP290 Three Zone + Two Zone Pre-Plumbed Cylinder with Integrated Buffer (Note. requires additional 3rd party electrical wiring for a 3rd zone)	11
Figure 9. HP290 Three Zone + Two Zone Pre-Plumbed Cylinder with Integrated Low Loss Header (Note, requires additional 3rd Party Electrical wiring for a 3rd zone)	12
Figure 10. HP290 + Decoupling Buffer for Heating Only with One Zone	13
Figure 11. HP290 + Volumiser for Heating Only with One Zone	14
Figure 12. HP290 + Combi Boiler + Buffer + Two Zones (Bivalent System)	15
Figure 13. HP290 + Combi Boiler + Single Zone (Bivalent System)	16
Figure 14. HP290 + Heating Only + System Boiler + Buffer + Two Zones (Bivalent System).....	17
Figure 15. HP290 + System Boiler + DHW + Two Zones (Bivalent System)	18
Figure 16. HP290 + System Boiler + Two Zone Pre-plumbed Cylinder with Integrated Buffer (Bivalent System).....	19
Figure 17. Hydraulically separated HP290 + System Boiler + DHW + Two Zones (Bivalent System).....	20
Figure 18. HP290 Heat Only Cascade + Decoupler with Two Zones.....	21
Figure 19. HP290 Cascade + 3rd Party DHW Cylinder + Cylinder + Decoupler with Two Zones.....	22
Figure 20. HP290 Cascade + 3rd Party DHW Cylinder + Multi-Port Decoupler with Two Zones.....	23
Figure 21. HP290 Heat Only Cascade + Multi-Port Decoupler with Two Zones	24
Figure 22. HP290 + Pre-plumbed Lite Heat Pump Cylinder + 2 Zone Valves.....	25

**① IMPORTANT: PLEASE USE THIS MANUAL IN CONJUNCTION
WITH THE HP290 MONOBLOC HEAT PUMP SYSTEM –
INSTALLATION & SERVICING MANUAL**

Figure 1. Schematics Key/Legend

LEGEND

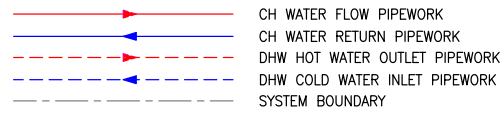

COMPONENT SYMBOLS

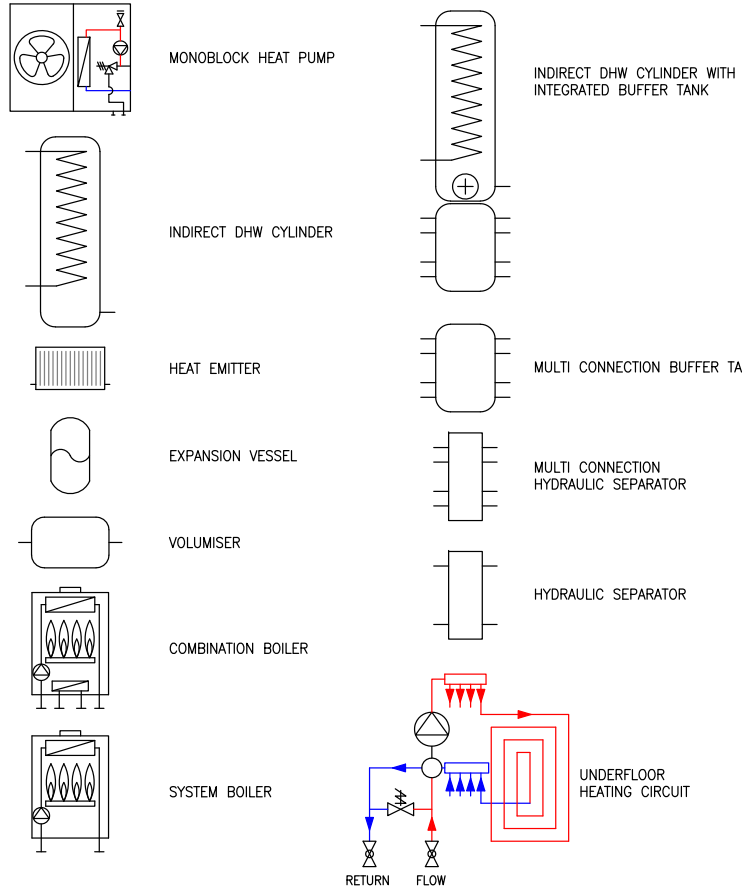
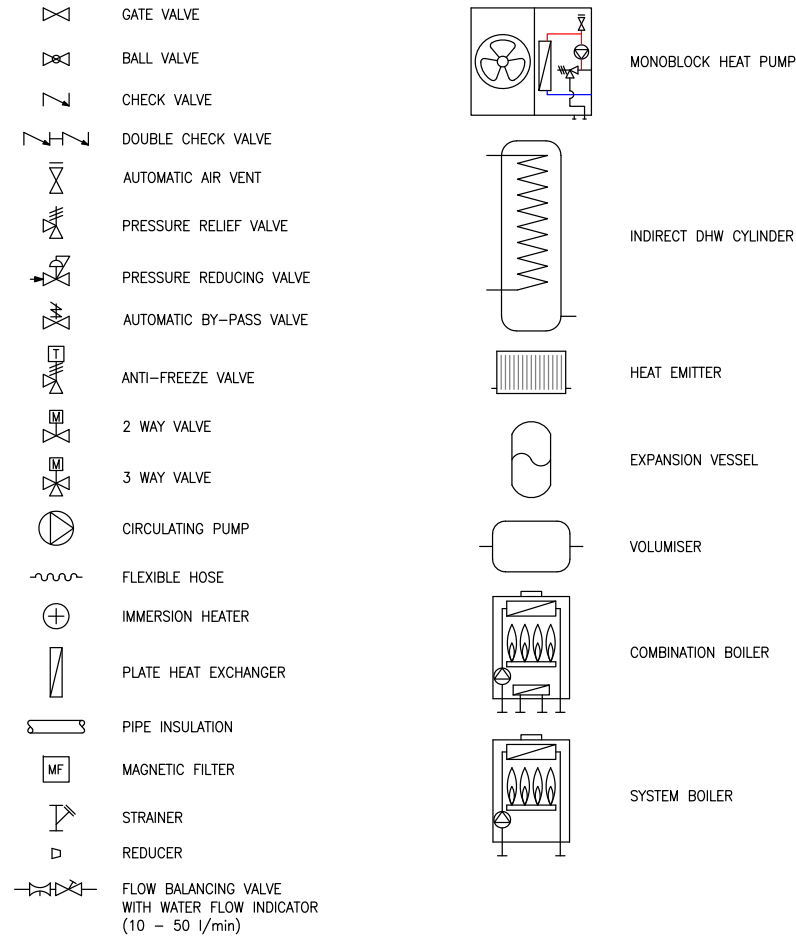

INSTRUMENT ABBREVIATIONS
(HP290 CONTROL BOX CONNECTIONS)



Refer to HP290 monobloc heat pump system installation and maintenance manual in conjunction with these schematic drawings.

CONNECTION POINT LIST

TP No	DESCRIPTION	SIZE 4.5-6kW	SIZE 8-14kW	MATERIAL	TYPE
1	HEAT PUMP FLOW	1" BSP	1. 1/4" BSP	BRASS	BSP MALE
2	HEAT PUMP RETURN	1" BSP	1. 1/4" BSP	BRASS	BSP MALE
3	HEAT PUMP CONDENSATE DISPOSAL	32MM OD	32MM OD	PLASTIC	BARBED SPIGOT
4	PRESSURE RELIEF VALVE (PRV)	9MM ID	9MM ID	PVC	HOSE
5	CYLINDER HEAT PUMP FLOW	28MM	28MM	BRASS	COMPRESSION
6	CYLINDER HEAT PUMP RETURN	28MM	28MM	BRASS	COMPRESSION
7	ZONE 1 FLOW	28MM	28MM	BRASS	COMPRESSION
8	ZONE 1 RETURN	28MM	28MM	BRASS	COMPRESSION

Figure 2. HP290 + Single Zone Pre-plumbed Cylinder with Integrated Buffer

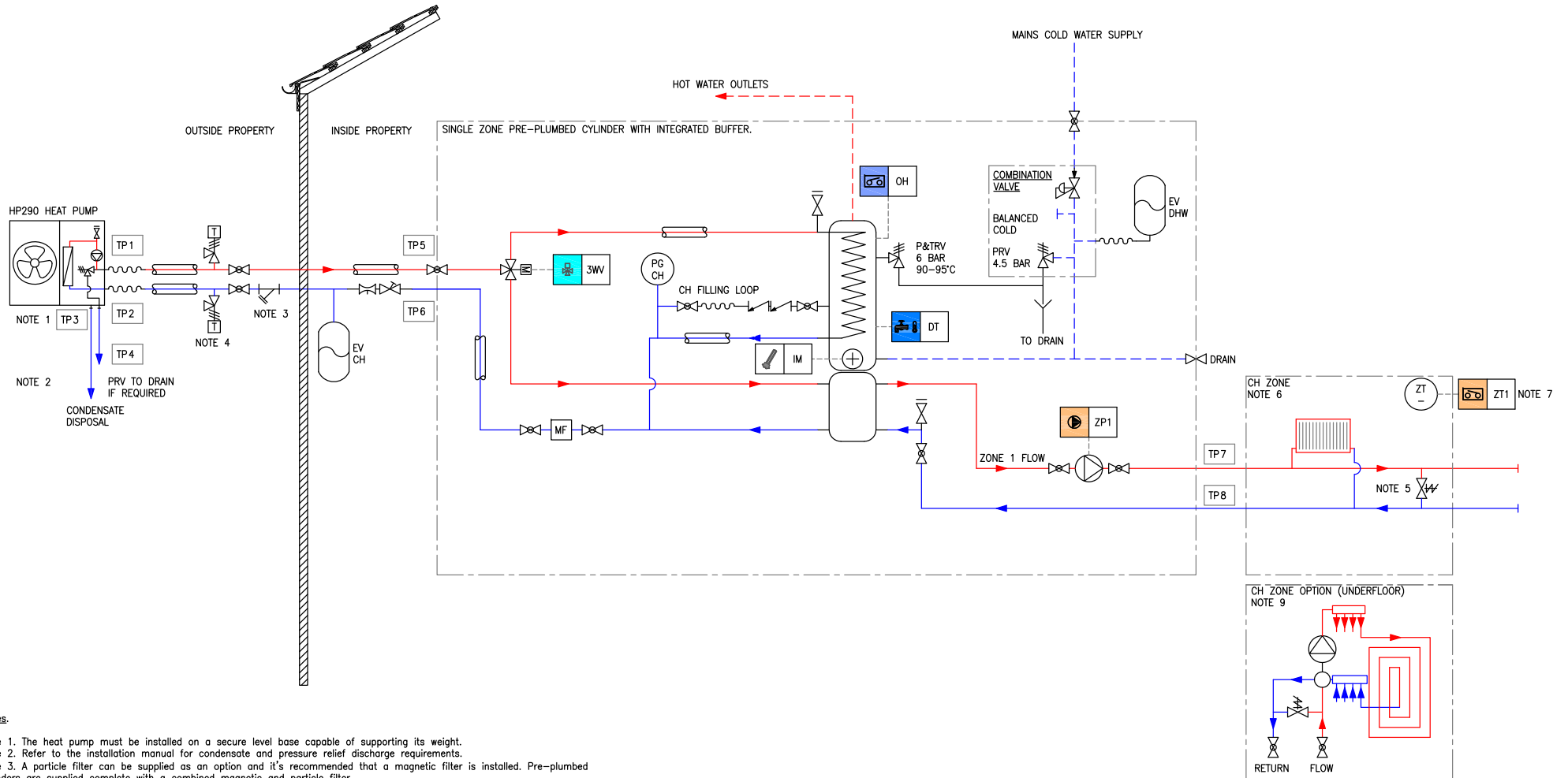

- Notes.**
- Note 1. The heat pump must be installed on a secure level base capable of supporting its weight.
 - Note 2. Refer to the installation manual for condensate and pressure relief discharge requirements.
 - Note 3. A particle filter can be supplied as an option and it's recommended that a magnetic filter is installed. Pre-plumbed cylinders are supplied complete with a combined magnetic and particle filter.
 - Note 4. Anti-freeze valves are required if glycol is not used in the system.
 - Note 5. Install an auto-bypass if no permanent open circuit is available to allow secondary side pump overrun and normal operation.
 - Note 6. Two zone pre-plumbed arrangement is available.
 - Note 7. Refer to the installation manual for thermostat connection.
 - Note 8. Flow, return and outdoor sensors are integrated within the outdoor unit.
 - Note 9. Underfloor heating circuit option. Refer to the manufacturers installation instructions for pump and bypass requirements.

This drawing is for information and guidance only. It is the heating designer/ installers responsibility to adhere to the latest relevant standards.
 Refer to HP290 heat pump system installation and maintenance manual in conjunction with these schematic drawings.

CONNECTION POINT LIST					
TP No	DESCRIPTION	SIZE 4.5-6kW	SIZE 8-14kW	MATERIAL	TYPE
1	HEAT PUMP FLOW	1" BSP	1. 1/4" BSP	BRASS	BSP MALE
2	HEAT PUMP RETURN	1" BSP	1. 1/4" BSP	BRASS	BSP MALE
3	HEAT PUMP CONDENSATE DISPOSAL	32MM OD	32MM OD	PLASTIC	BARBED SPIGOT
4	PRESSURE RELIEF VALVE (PRV)	9MM ID	9MM ID	PVC	HOSE
5	CYLINDER HEAT PUMP FLOW	28MM	28MM	BRASS	COMPRESSION
6	CYLINDER HEAT PUMP RETURN	28MM	28MM	BRASS	COMPRESSION
7	ZONE 1 FLOW	28MM	28MM	BRASS	COMPRESSION
8	ZONE 1 RETURN	28MM	28MM	BRASS	COMPRESSION
9	ZONE 2 FLOW	28MM	28MM	BRASS	COMPRESSION
10	ZONE 2 RETURN	28MM	28MM	BRASS	COMPRESSION

Figure 3. HP290 + Two Zone Pre-Plumbed Cylinder with Integrated Buffer

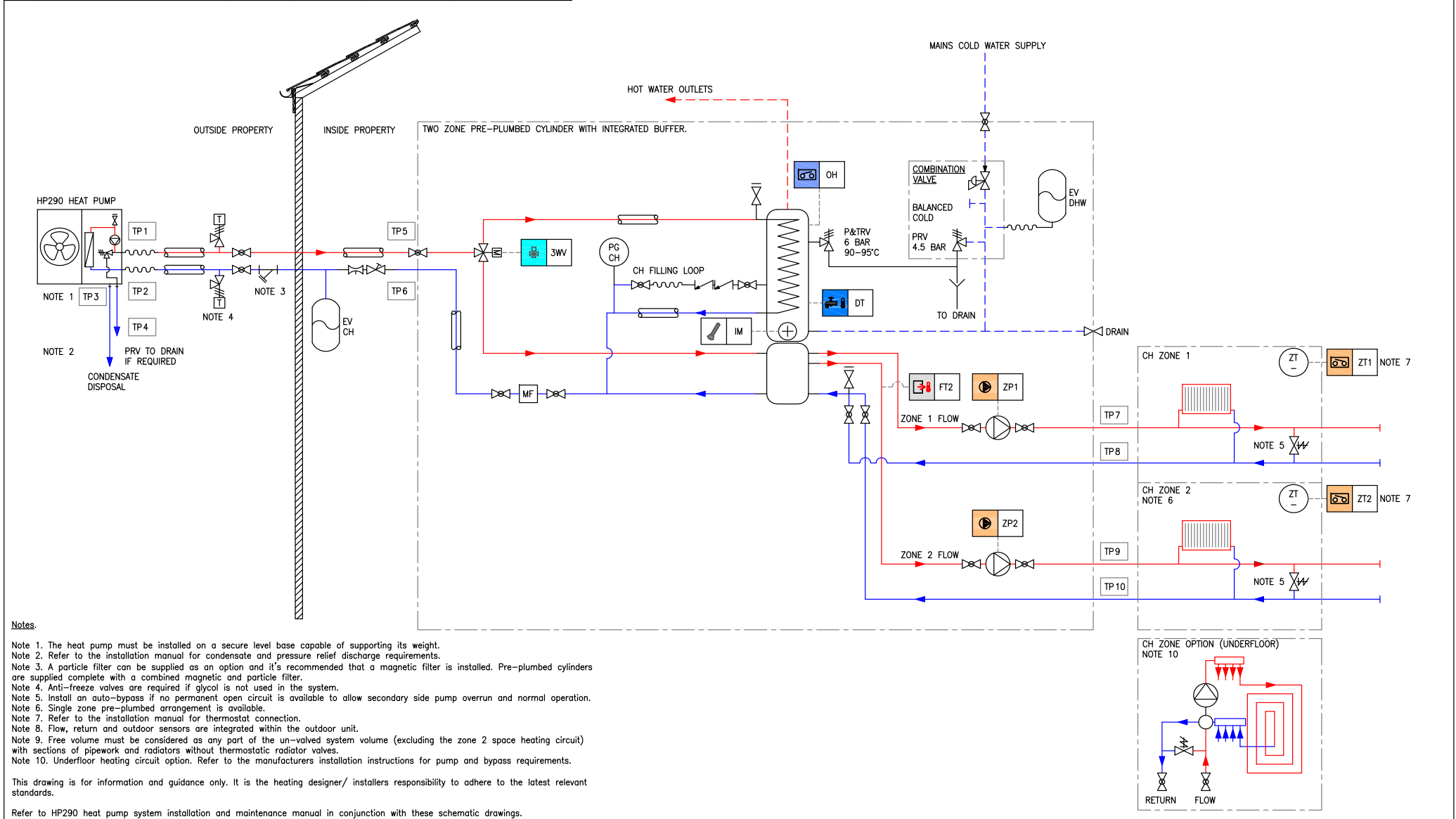

CONNECTION POINT LIST					
TP No	DESCRIPTION	SIZE 4.5-6kW	SIZE 8-14kW	MATERIAL	TYPE
1	HEAT PUMP FLOW	1" BSP	1. 1/4" BSP	BRASS	BSP MALE
2	HEAT PUMP RETURN	1" BSP	1. 1/4" BSP	BRASS	BSP MALE
3	HEAT PUMP CONDENSATE DISPOSAL	32MM OD	32MM OD	PLASTIC	BARBED SPIGOT
4	PRESSURE RELIEF VALVE (PRV)	9MM ID	9MM ID	PVC	HOSE
5	CYLINDER HEAT PUMP FLOW	28MM	28MM	BRASS	COMPRESSION
6	CYLINDER HEAT PUMP RETURN	28MM	28MM	BRASS	COMPRESSION
7	ZONE 1 FLOW	28MM	28MM	BRASS	COMPRESSION
8	ZONE 1 RETURN	28MM	28MM	BRASS </td <td>COMPRESSION</td>	COMPRESSION

Figure 4. HP290 + Single Zone Pre-Plumbed Cylinder

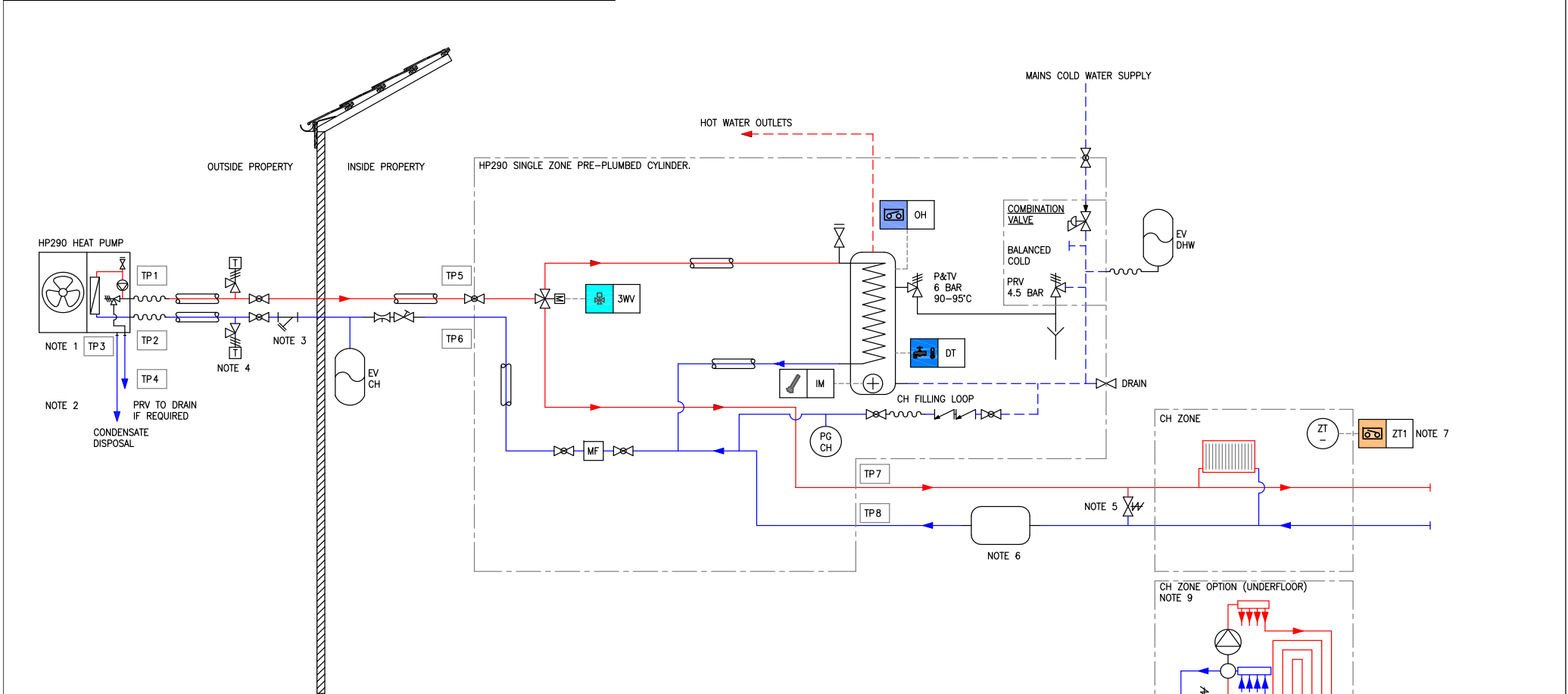

- Notes.**
- Note 1. The heat pump must be installed on a secure level base capable of supporting its weight.
 - Note 2. Refer to the installation manual for condensate and pressure relief discharge requirements.
 - Note 3. A particle filter can be supplied as an option and it's recommended that a magnetic filter is installed. Pre-plumbed cylinders are supplied complete with a combined magnetic and particle filter.
 - Note 4. Anti-freeze valves are required if glycol is not used in the system.
 - Note 5. Install an auto-bypass if no permanent open circuit is available to allow pump overrun and normal operation. Ensuring minimum circulating water flow rate for heat pump defrost requirements.
 - Note 6. If minimum free system water volume cannot be met, a volumiser is required.
 - Note 7. Refer to the installation manual for thermostat connection.
 - Note 8. Flow, return and outdoor sensors are integrated within the outdoor unit.
 - Note 9. Underfloor heating circuit option. Refer to the manufacturers installation instructions for pump and bypass requirements.

This drawing is for information and guidance only. It is the heating designer/installers responsibility to adhere to the latest relevant standards.
 Refer to HP290 heat pump system installation and maintenance manual in conjunction with these schematic drawings.

CONNECTION POINT LIST					
TP No	DESCRIPTION	SIZE 4.5-6kW	SIZE 8-14kW	MATERIAL	TYPE
1	HEAT PUMP FLOW	1" BSP	1. 1/4" BSP	BRASS	BSP MALE
2	HEAT PUMP RETURN	1" BSP	1. 1/4" BSP	BRASS	BSP MALE
3	HEAT PUMP CONDENSATE DISPOSAL	32MM OD	32MM OD	PLASTIC	BARBED SPIGOT
4	PRESSURE RELIEF VALVE (PRV)	9MM ID	9MM ID	PVC	HOSE

Figure 5. HP290 + Standard Non Pre-Plumbed Heat Pump Cylinder + Buffer with Single Zone

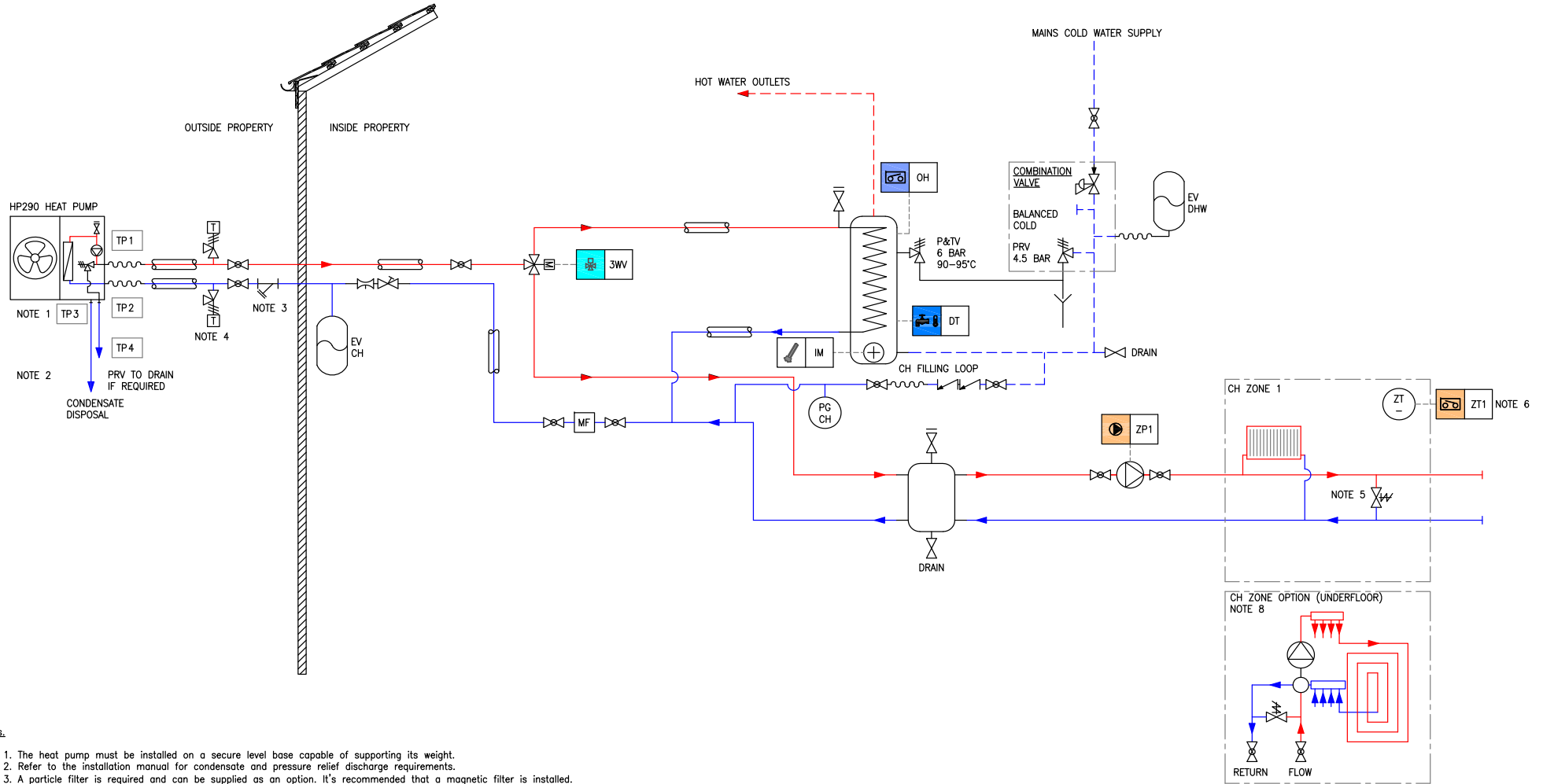

Notes.

- Note 1. The heat pump must be installed on a secure level base capable of supporting its weight.
- Note 2. Refer to the installation manual for condensate and pressure relief discharge requirements.
- Note 3. A particle filter is required and can be supplied as an option. It's recommended that a magnetic filter is installed.
- Note 4. Anti-freeze valves are required if glycol is not used in the system.
- Note 5. Install an auto-bypass if no permanent open circuit is available to allow secondary side pump overrun and normal operation.
- Note 6. Refer to the installation manual for thermostat connection.
- Note 7. Flow, return and outdoor sensors are integrated within the outdoor unit.
- Note 8. Underfloor heating circuit option. Refer to the manufacturers installation instructions for pump and bypass requirements.

This drawing is for information and guidance only. It is the heating designer/installers responsibility to adhere to the latest relevant standards.

Refer to HP290 heat pump system installation and maintenance manual in conjunction with these schematic drawings.

CONNECTION POINT LIST					
TP No	DESCRIPTION	SIZE 4.5-6kW	SIZE 8-14kW	MATERIAL	TYPE
1	HEAT PUMP FLOW	1" BSP	1. 1/4" BSP	BRASS	BSP MALE
2	HEAT PUMP RETURN	1" BSP	1. 1/4" BSP	BRASS	BSP MALE
3	HEAT PUMP CONDENSATE DISPOSAL	32MM OD	32MM OD	PLASTIC	BARBED SPIGOT
4	PRESSURE RELIEF VALVE (PRV)	9MM ID	9MM ID	PVC	HOSE

Figure 6. HP290 + Standard Non Pre-Plumbed Heat Pump Cylinder + Buffer with Two Zones

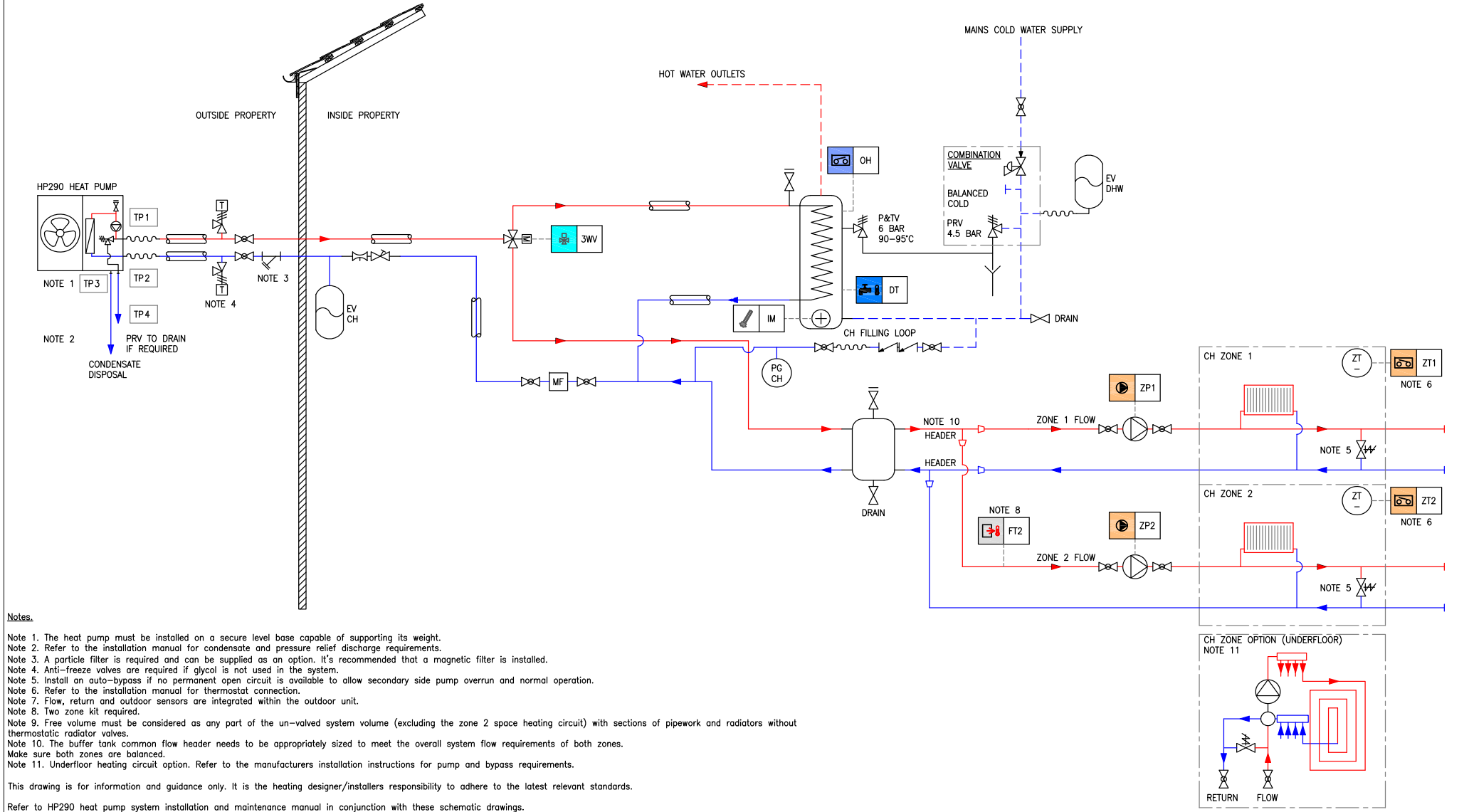

Notes.

Note 1. The heat pump must be installed on a secure level base capable of supporting its weight.
 Note 2. Refer to the installation manual for condensate and pressure relief discharge requirements.
 Note 3. A particle filter is required and can be supplied as an option. It's recommended that a magnetic filter is installed.
 Note 4. Anti-freeze valves are required if glycol is not used in the system.
 Note 5. Install an auto-bypass if no permanent open circuit is available to allow secondary side pump overrun and normal operation.
 Note 6. Refer to the installation manual for thermostat connection.
 Note 7. Flow, return and outdoor sensors are integrated within the outdoor unit.
 Note 8. Two zone kit required.
 Note 9. Free volume must be considered as any part of the un-valved system volume (excluding the zone 2 space heating circuit) with sections of pipework and radiators without thermostatic radiator valves.
 Note 10. The buffer tank common flow header needs to be appropriately sized to meet the overall system flow requirements of both zones. Make sure both zones are balanced.
 Note 11. Underfloor heating circuit option. Refer to the manufacturers installation instructions for pump and bypass requirements.

This drawing is for information and guidance only. It is the heating designer/installers responsibility to adhere to the latest relevant standards.
 Refer to HP290 heat pump system installation and maintenance manual in conjunction with these schematic drawings.

CONNECTION POINT LIST					
TP No	DESCRIPTION	SIZE 4.5-6kW	SIZE 8-14kW	MATERIAL	TYPE
1	HEAT PUMP FLOW	1" BSP	1. 1/4" BSP	BRASS	BSP MALE
2	HEAT PUMP RETURN	1" BSP	1. 1/4" BSP	BRASS	BSP MALE
3	HEAT PUMP CONDENSATE DISPOSAL	32MM OD	32MM OD	PLASTIC	BARBED SPIGOT
4	PRESSURE RELIEF VALVE (PRV)	9MM ID	9MM ID	PVC	HOSE
5	CYLINDER HEAT PUMP FLOW	28MM	28MM	BRASS	COMPRESSION
6	CYLINDER HEAT PUMP RETURN	28MM	28MM	BRASS	COMPRESSION
7	ZONE 1 FLOW	28MM	28MM	BRASS	COMPRESSION
8	ZONE 1 RETURN	28MM	28MM	BRASS	COMPRESSION
9	ZONE 2 FLOW	28MM	28MM	BRASS	COMPRESSION
10	ZONE 2 RETURN	28MM	28MM	BRASS	COMPRESSION

Figure 7. HP290 + Two Zone Pre-Plumbed Cylinder with Integrated Low Loss Header

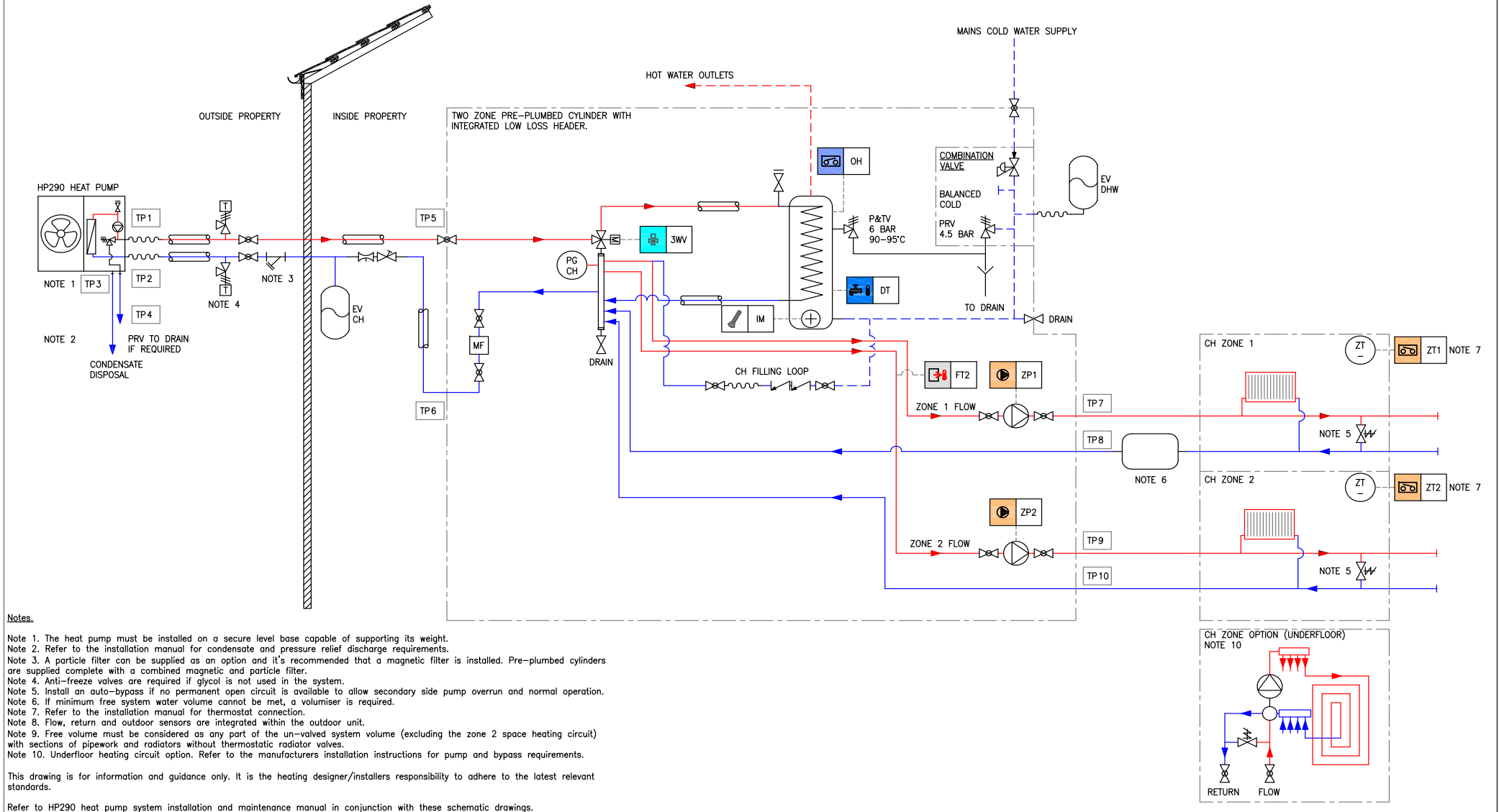

Notes.

- Note 1. The heat pump must be installed on a secure level base capable of supporting its weight.
- Note 2. Refer to the installation manual for condensate and pressure relief discharge requirements.
- Note 3. A particle filter can be supplied as an option and it's recommended that a magnetic filter is installed. Pre-plumbed cylinders are supplied complete with a combined magnetic and particle filter.
- Note 4. Anti-freeze valves are required if glycol is not used in the system.
- Note 5. Install an auto-bypass if no permanent open circuit is available to allow secondary side pump overrun and normal operation.
- Note 6. If minimum free system water volume cannot be met, a volumiser is required.
- Note 7. Refer to the installation manual for thermostat connection.
- Note 8. Flow, return and outdoor sensors are integrated within the outdoor unit.
- Note 9. Free volume must be considered as any part of the un-valved system volume (excluding the zone 2 space heating circuit) with sections of pipework and radiators without thermostatic radiator valves.
- Note 10. Underfloor heating circuit option. Refer to the manufacturers installation instructions for pump and bypass requirements.

This drawing is for information and guidance only. It is the heating designer/installers responsibility to adhere to the latest relevant standards.

Refer to HP290 heat pump system installation and maintenance manual in conjunction with these schematic drawings.

CONNECTION POINT LIST					
TP No	DESCRIPTION	SIZE 4.5-6kW	SIZE 8-14kW	MATERIAL	TYPE
1	HEAT PUMP FLOW	1" BSP	1. 1/4" BSP	BRASS	BSP MALE
2	HEAT PUMP RETURN	1" BSP	1. 1/4" BSP	BRASS	BSP MALE
3	HEAT PUMP CONDENSATE DISPOSAL	32MM OD	32MM OD	PLASTIC	BARBED SPIGOT
4	PRESSURE RELIEF VALVE (PRV)	9MM ID	9MM ID	PVC	HOSE
5	CYLINDER HEAT PUMP FLOW	28MM	28MM	BRASS	COMPRESSION
6	CYLINDER HEAT PUMP RETURN	28MM	28MM	BRASS	COMPRESSION
7	ZONE 1 FLOW	28MM	28MM	BRASS	COMPRESSION
8	ZONE 1 RETURN	28MM	28MM	BRASS	COMPRESSION
9	ZONE 2 FLOW	28MM	28MM	BRASS	COMPRESSION
10	ZONE 2 RETURN	28MM	28MM	BRASS </td <td>COMPRESSION</td>	COMPRESSION

Figure 8. HP290 Three Zone + Two Zone Pre-Plumbed Cylinder with Integrated Buffer
(Note. requires additional 3rd party electrical wiring for a 3rd zone)

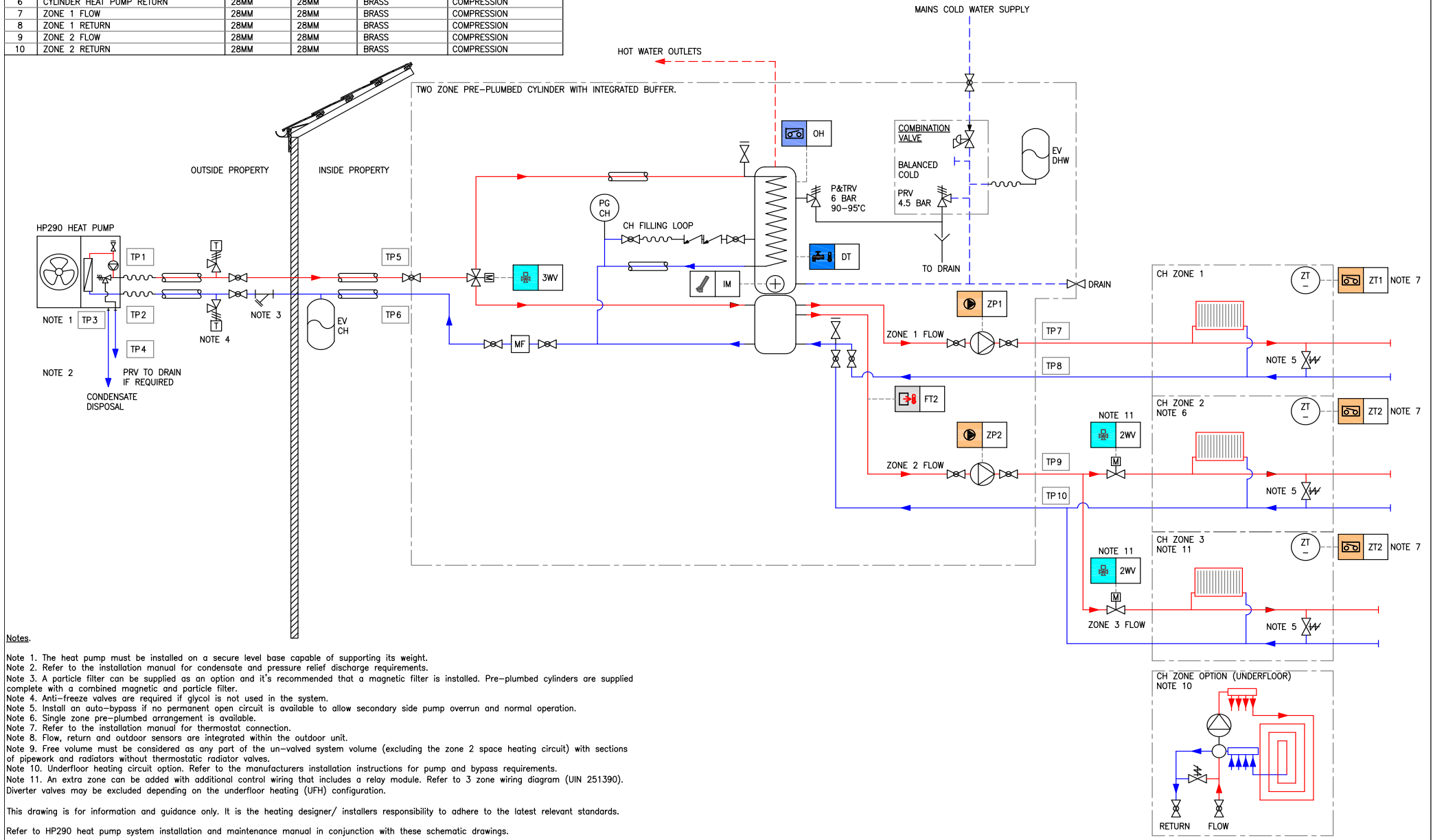

Notes.

Note 1. The heat pump must be installed on a secure level base capable of supporting its weight.
 Note 2. Refer to the installation manual for condensate and pressure relief discharge requirements.
 Note 3. A particle filter can be supplied as an option and it's recommended that a magnetic filter is installed. Pre-plumbed cylinders are supplied complete with a combined magnetic and particle filter.
 Note 4. Anti-freeze valves are required if glycol is not used in the system.
 Note 5. Install an auto-bypass if no permanent open circuit is available to allow secondary side pump overrun and normal operation.
 Note 6. Single zone pre-plumbed arrangement is available.
 Note 7. Refer to the installation manual for thermostat connection.
 Note 8. Flow, return and outdoor sensors are integrated within the outdoor unit.
 Note 9. Free volume must be considered as any part of the un-valved system volume (excluding the zone 2 space heating circuit) with sections of pipework and radiators without thermostatic radiator valves.
 Note 10. Underfloor heating circuit option. Refer to the manufacturers installation instructions for pump and bypass requirements.
 Note 11. An extra zone can be added with additional control wiring that includes a relay module. Refer to 3 zone wiring diagram (UIN 251390). Diverter valves may be excluded depending on the underfloor heating (UFH) configuration.

This drawing is for information and guidance only. It is the heating designer/ installers responsibility to adhere to the latest relevant standards.
 Refer to HP290 heat pump system installation and maintenance manual in conjunction with these schematic drawings.

CONNECTION POINT LIST					
TP No	DESCRIPTION	SIZE 4.5-6kW	SIZE 8-14kW	MATERIAL	TYPE
1	HEAT PUMP FLOW	1" BSP	1. 1/4" BSP	BRASS	BSP MALE
2	HEAT PUMP RETURN	1" BSP	1. 1/4" BSP	BRASS	BSP MALE
3	HEAT PUMP CONDENSATE DISPOSAL	32MM OD	32MM OD	PLASTIC	BARBED SPIGOT
4	PRESSURE RELIEF VALVE (PRV)	9MM ID	9MM ID	PVC	HOSE
5	CYLINDER HEAT PUMP FLOW	28MM	28MM	BRASS	COMPRESSION
6	CYLINDER HEAT PUMP RETURN	28MM	28MM	BRASS	COMPRESSION
7	ZONE 1 FLOW	28MM	28MM	BRASS	COMPRESSION
8	ZONE 1 RETURN	28MM	28MM	BRASS	COMPRESSION
9	ZONE 2 FLOW	28MM	28MM	BRASS	COMPRESSION
10	ZONE 2 RETURN	28MM	28MM	BRASS </td <td>COMPRESSION</td>	COMPRESSION

Figure 9. HP290 Three Zone + Two Zone Pre-Plumbed Cylinder with Integrated Low Loss Header
(Note, requires additional 3rd Party Electrical wiring for a 3rd zone)

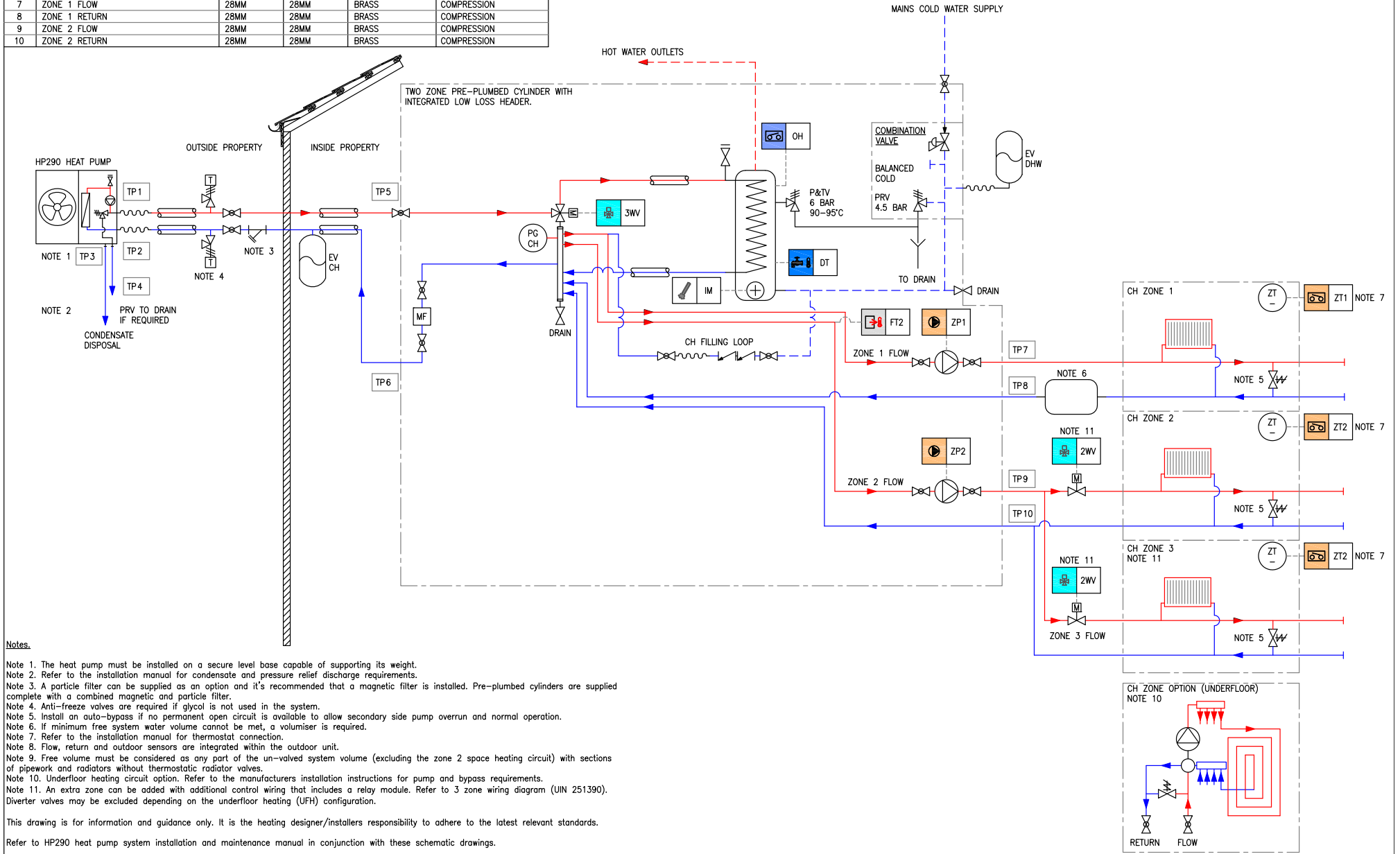

Notes.

- Note 1. The heat pump must be installed on a secure level base capable of supporting its weight.
- Note 2. Refer to the installation manual for condensate and pressure relief discharge requirements.
- Note 3. A particle filter can be supplied as an option and it's recommended that a magnetic filter is installed. Pre-plumbed cylinders are supplied complete with a combined magnetic and particle filter.
- Note 4. Anti-freeze valves are required if glycol is not used in the system.
- Note 5. Install an auto-bypass if no permanent open circuit is available to allow secondary side pump overrun and normal operation.
- Note 6. If minimum free system water volume cannot be met, a volumiser is required.
- Note 7. Refer to the installation manual for thermostat connection.
- Note 8. Flow, return and outdoor sensors are integrated within the outdoor unit.
- Note 9. Free volume must be considered as any part of the un-valved system volume (excluding the zone 2 space heating circuit) with sections of pipework and radiators without thermostatic radiator valves.
- Note 10. Underfloor heating circuit option. Refer to the manufacturers installation instructions for pump and bypass requirements.
- Note 11. An extra zone can be added with additional control wiring that includes a relay module. Refer to 3 zone wiring diagram (UIN 251390). Diverter valves may be excluded depending on the underfloor heating (UFH) configuration.

This drawing is for information and guidance only. It is the heating designer/installers responsibility to adhere to the latest relevant standards.
Refer to HP290 heat pump system installation and maintenance manual in conjunction with these schematic drawings.

CONNECTION POINT LIST					
TP No	DESCRIPTION	SIZE 4.5-6kW	SIZE 8-14kW	MATERIAL	TYPE
1	HEAT PUMP FLOW	1" BSP	1. 1/4" BSP	BRASS	BSP MALE
2	HEAT PUMP RETURN	1" BSP	1. 1/4" BSP	BRASS	BSP MALE
3	HEAT PUMP CONDENSATE DISPOSAL	32MM OD	32MM OD	PLASTIC	BARBED SPIGOT
4	PRESSURE RELIEF VALVE (PRV)	9MM ID	9MM ID	PVC	HOSE

Figure 10. HP290 + Decoupling Buffer for Heating Only with One Zone

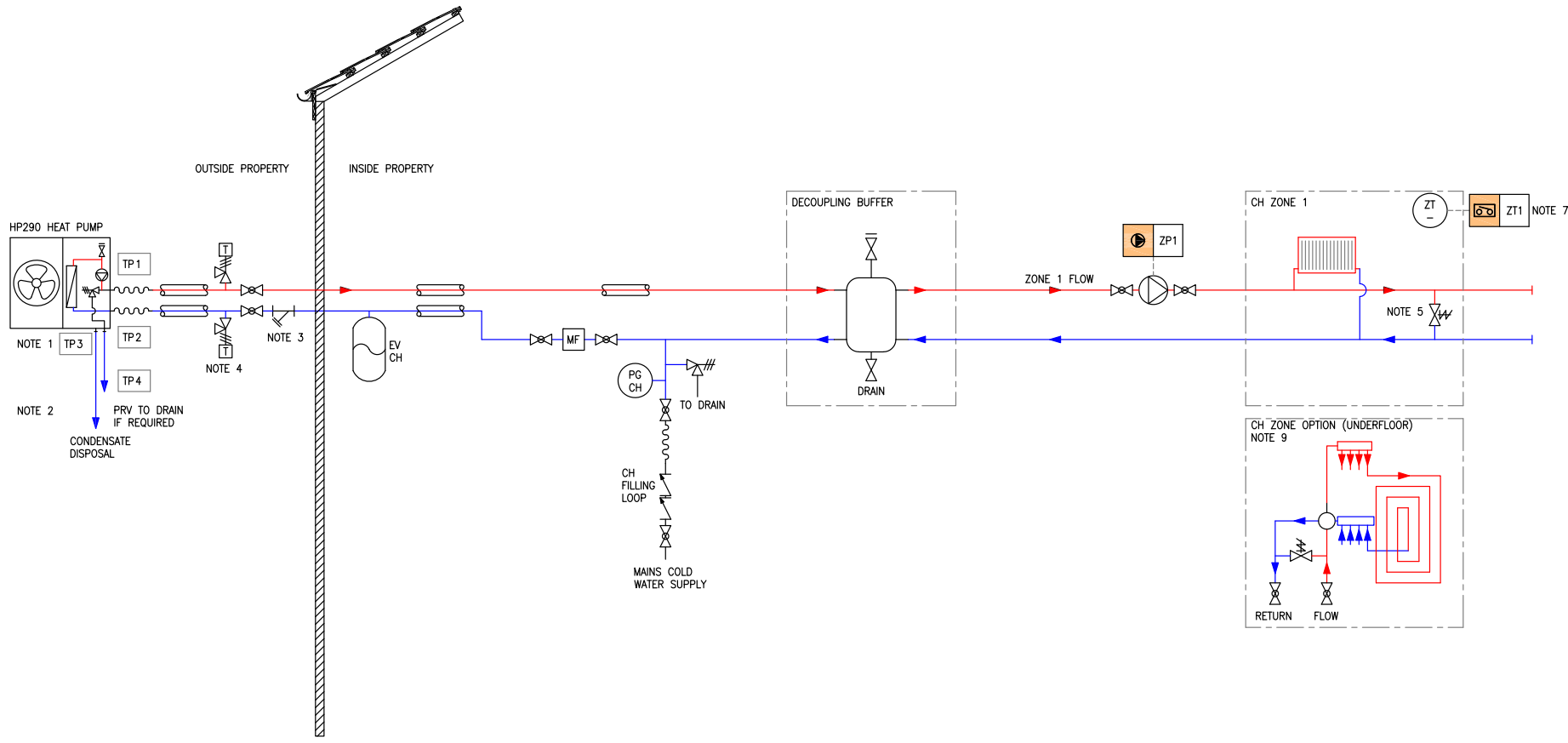

- Notes.**
- Note 1. The heat pump must be installed on a secure level base capable of supporting its weight.
 - Note 2. Refer to the installation manual for condensate and pressure relief discharge requirements.
 - Note 3. A particle filter can be supplied as an option and it's recommended that a magnetic filter is installed. Pre-plumbed cylinders are supplied complete with a combined magnetic and particle filter.
 - Note 4. Anti-freeze valves are required if glycol is not used in the system.
 - Note 5. Install an auto-bypass if no permanent open circuit is available to allow pump overrun and normal operation. Ensuring minimum circulating water flow rate for heat pump defrost requirements.
 - Note 6. If minimum free system water volume cannot be met, a volumiser is required.
 - Note 7. Refer to the installation manual for thermostat connection.
 - Note 8. Flow, return and outdoor sensors are integrated within the outdoor unit.
 - Note 9. Underfloor heating circuit option. Refer to the manufacturers installation instructions for pump and bypass requirements.

This drawing is for information and guidance only. It is the heating designer/installers responsibility to adhere to the latest relevant standards.

Refer to HP290 heat pump system installation and maintenance manual in conjunction with these schematic drawings.

CONNECTION POINT LIST

TP No	DESCRIPTION	SIZE 4.5-6kW	SIZE 8-14kW	MATERIAL	TYPE
1	HEAT PUMP FLOW	1" BSP	1. 1/4" BSP	BRASS	BSP MALE
2	HEAT PUMP RETURN	1" BSP	1. 1/4" BSP	BRASS	BSP MALE
3	HEAT PUMP CONDENSATE DISPOSAL	32MM OD	32MM OD	PLASTIC	BARBED SPIGOT
4	PRESSURE RELIEF VALVE (PRV)	9MM ID	9MM ID	PVC	HOSE

Figure 11. HP290 + Volumiser for Heating Only with One Zone

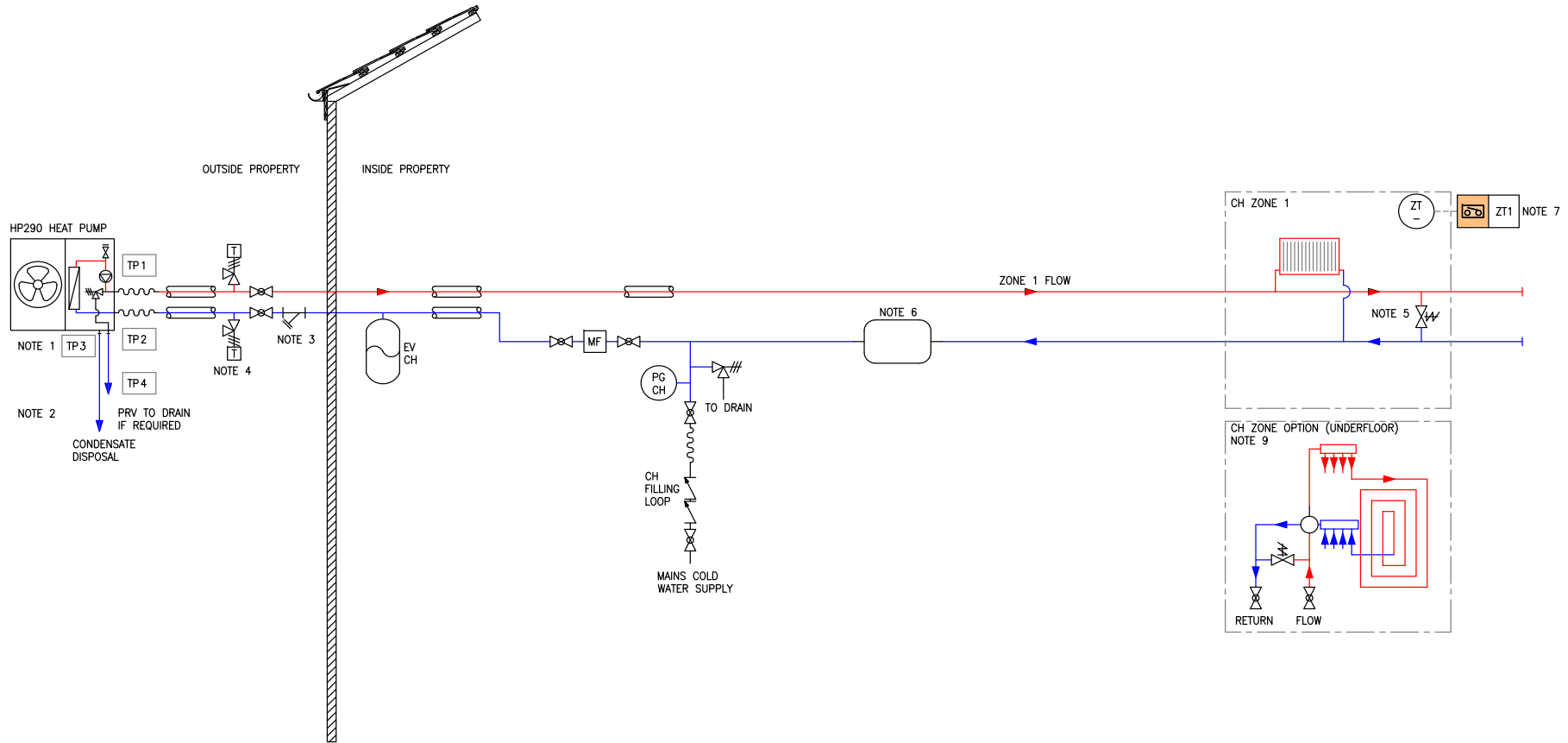

Notes.

- Note 1. The heat pump must be installed on a secure level base capable of supporting its weight.
- Note 2. Refer to the installation manual for condensate and pressure relief discharge requirements.
- Note 3. A particle filter can be supplied as an option and it's recommended that a magnetic filter is installed. Pre-plumbed cylinders are supplied complete with a combined magnetic and particle filter.
- Note 4. Anti-freeze valves are required if glycol is not used in the system.
- Note 5. Install an auto-bypass if no permanent open circuit is available to allow pump overrun and normal operation. Ensuring minimum circulating water flow rate for heat pump defrost requirements.
- Note 6. If minimum free system water volume cannot be met, a volumiser is required.
- Note 7. Refer to the installation manual for thermostat connection.
- Note 8. Flow, return and outdoor sensors are integrated within the outdoor unit.
- Note 9. Underfloor heating circuit option. Refer to the manufacturers installation instructions for pump and bypass requirements.

This drawing is for information and guidance only. It is the heating designer/installers responsibility to adhere to the latest relevant standards.

Refer to HP290 heat pump system installation and maintenance manual in conjunction with these schematic drawings.

CONNECTION POINT LIST					
TP No	DESCRIPTION	SIZE 4.5-6kW	SIZE 8-14kW	MATERIAL	TYPE
1	HEAT PUMP FLOW	1" BSP	1. 1/4" BSP	BRASS	BSP MALE
2	HEAT PUMP RETURN	1" BSP	1. 1/4" BSP	BRASS	BSP MALE
3	HEAT PUMP CONDENSATE DISPOSAL	32MM OD	32MM OD	PLASTIC	BARBED SPIGOT
4	PRESSURE RELIEF VALVE (PRV)	9MM ID	9MM ID	PVC	HOSE

Figure 12. HP290 + Combi Boiler + Buffer + Two Zones (Bivalent System)

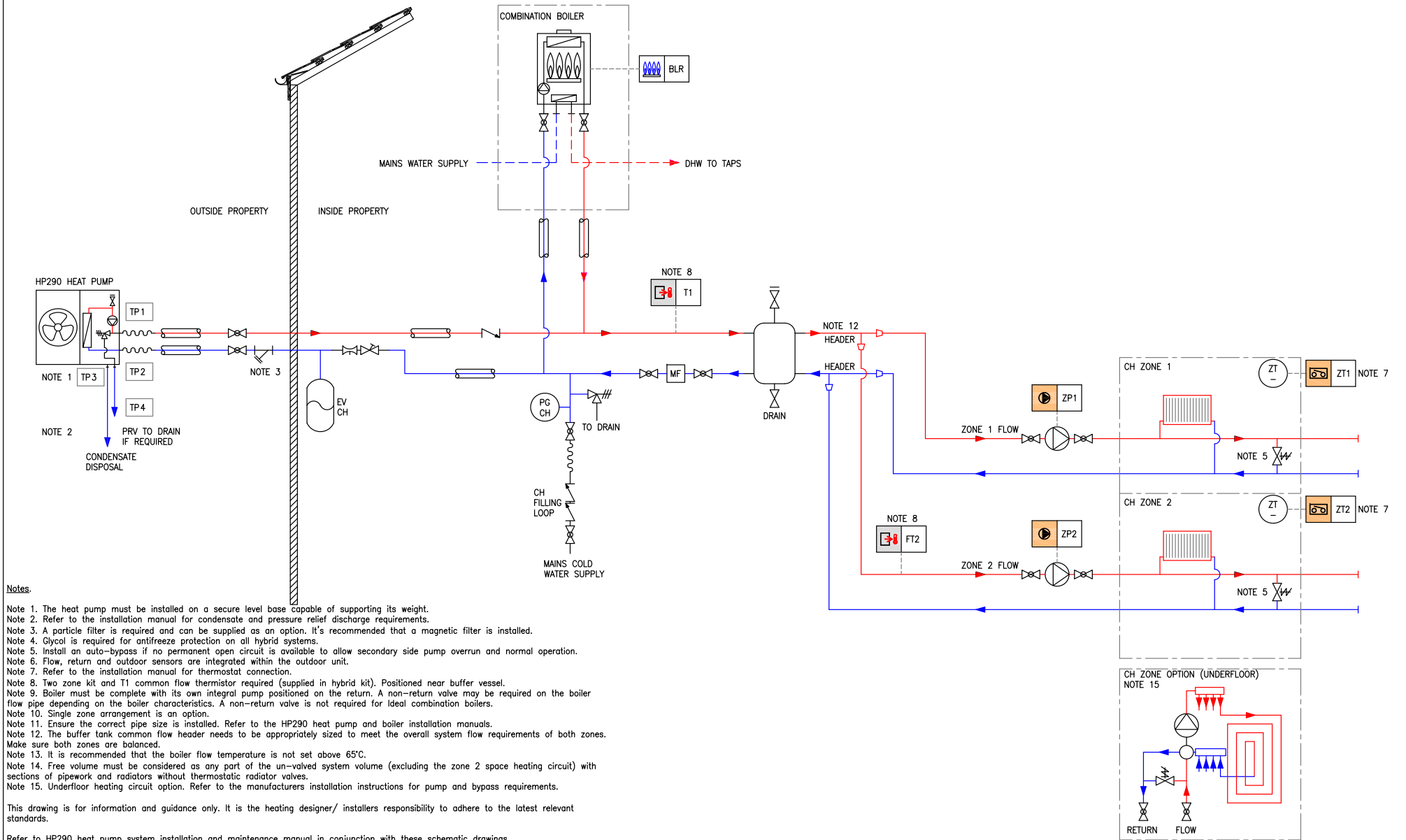

CONNECTION POINT LIST					
TP No	DESCRIPTION	SIZE 4.5-6kW	SIZE 8-14kW	MATERIAL	TYPE
1	HEAT PUMP FLOW	1" BSP	1. 1/4" BSP	BRASS	BSP MALE
2	HEAT PUMP RETURN	1" BSP	1. 1/4" BSP	BRASS	BSP MALE
3	HEAT PUMP CONDENSATE DISPOSAL	32MM OD	32MM OD	PLASTIC	BARBED SPIGOT
4	PRESSURE RELIEF VALVE (PRV)	9MM ID	9MM ID	PVC	HOSE

Figure 13. HP290 + Combi Boiler + Single Zone (Bivalent System)

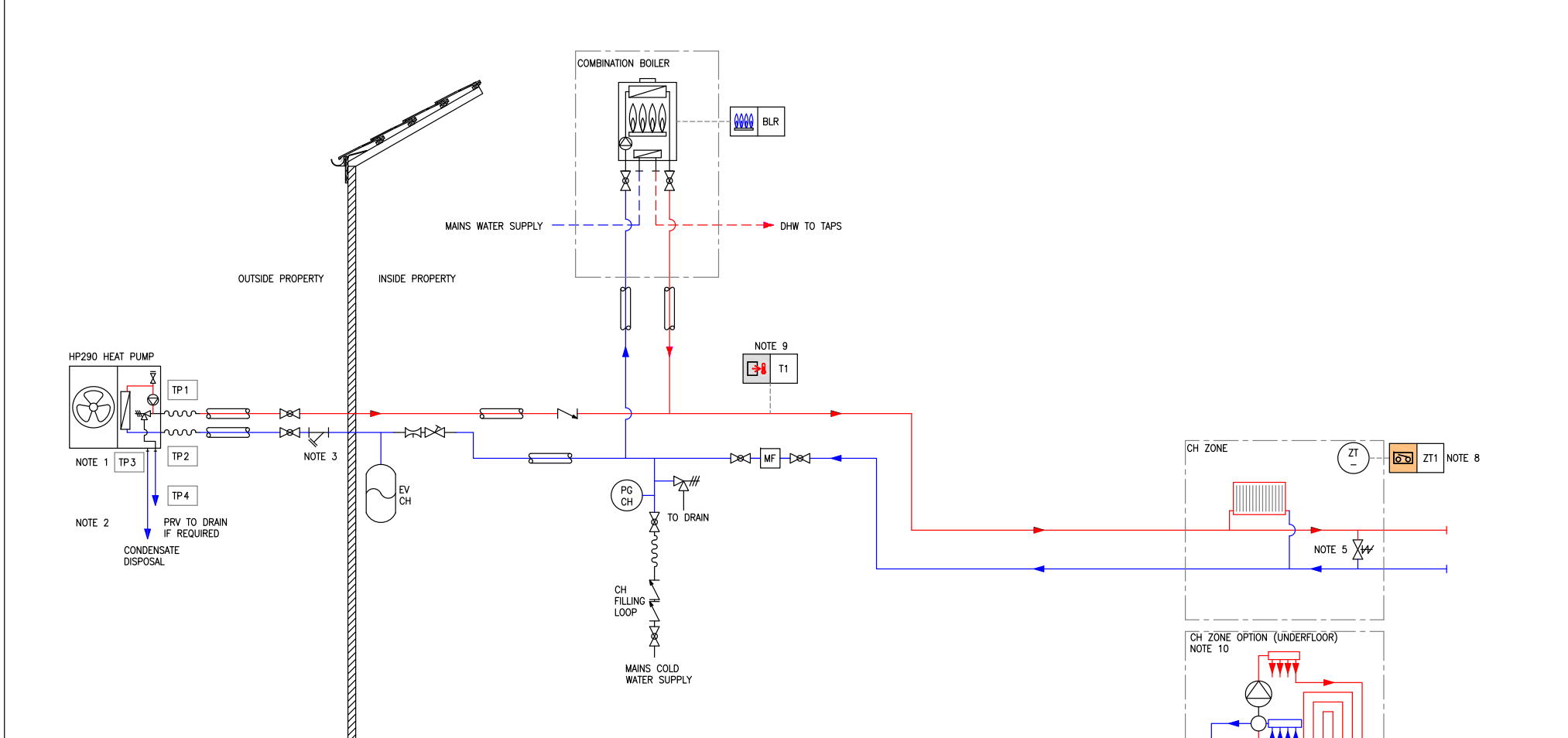

- Notes.**
- Note 1. The heat pump must be installed on a secure level base capable of supporting its weight.
 - Note 2. Refer to the installation manual for condensate and pressure relief discharge requirements.
 - Note 3. A particle filter is required and can be supplied as an option. It's recommended that a magnetic filter is installed.
 - Note 4. Glycol is required for antifreeze protection on all hybrid systems.
 - Note 5. Install an auto-bypass if no permanent open circuit is available to allow pump overrun and normal operation.
 - Note 6. If minimum free system water volume cannot be met, a volumiser is required. This is installed on the return circuit.
 - Note 7. Flow, return and outdoor sensors are integrated within the outdoor unit.
 - Note 8. Refer to the installation manual for thermostat connection.
 - Note 9. T1 sensor required (supplied in hybrid kit).
 - Note 10. Boiler must be complete with its own integral pump positioned on the return. A non-return valve may be required on the boiler flow pipe depending on the boiler characteristics. A non-return valve is not required for Ideal combination boilers.
 - Note 11. Ensure the correct pipe size is installed. Refer to the HP290 heat pump and boiler installation manuals.
 - Note 12. It is recommended that the boiler flow temperature is not set above 65°C.
 - Note 10. Underfloor heating circuit option. Refer to the manufacturers installation instructions for pump and bypass requirements.

This drawing is for information and guidance only. It is the heating designer/ installers responsibility to adhere to the latest relevant standards.
 Refer to HP290 heat pump system installation and maintenance manual in conjunction with these schematic drawings.

CONNECTION POINT LIST					
TP No	DESCRIPTION	SIZE 4.5-6kW	SIZE 8-14kW	MATERIAL	TYPE
1	HEAT PUMP FLOW	1" BSP	1. 1/4" BSP	BRASS	BSP MALE
2	HEAT PUMP RETURN	1" BSP	1. 1/4" BSP	BRASS	BSP MALE
3	HEAT PUMP CONDENSATE DISPOSAL	32MM OD	32MM OD	PLASTIC	BARBED SPIGOT
4	PRESSURE RELIEF VALVE (PRV)	9MM ID	9MM ID	PVC	HOSE

Figure 14. HP290 + Heating Only + System Boiler + Buffer + Two Zones (Bivalent System)

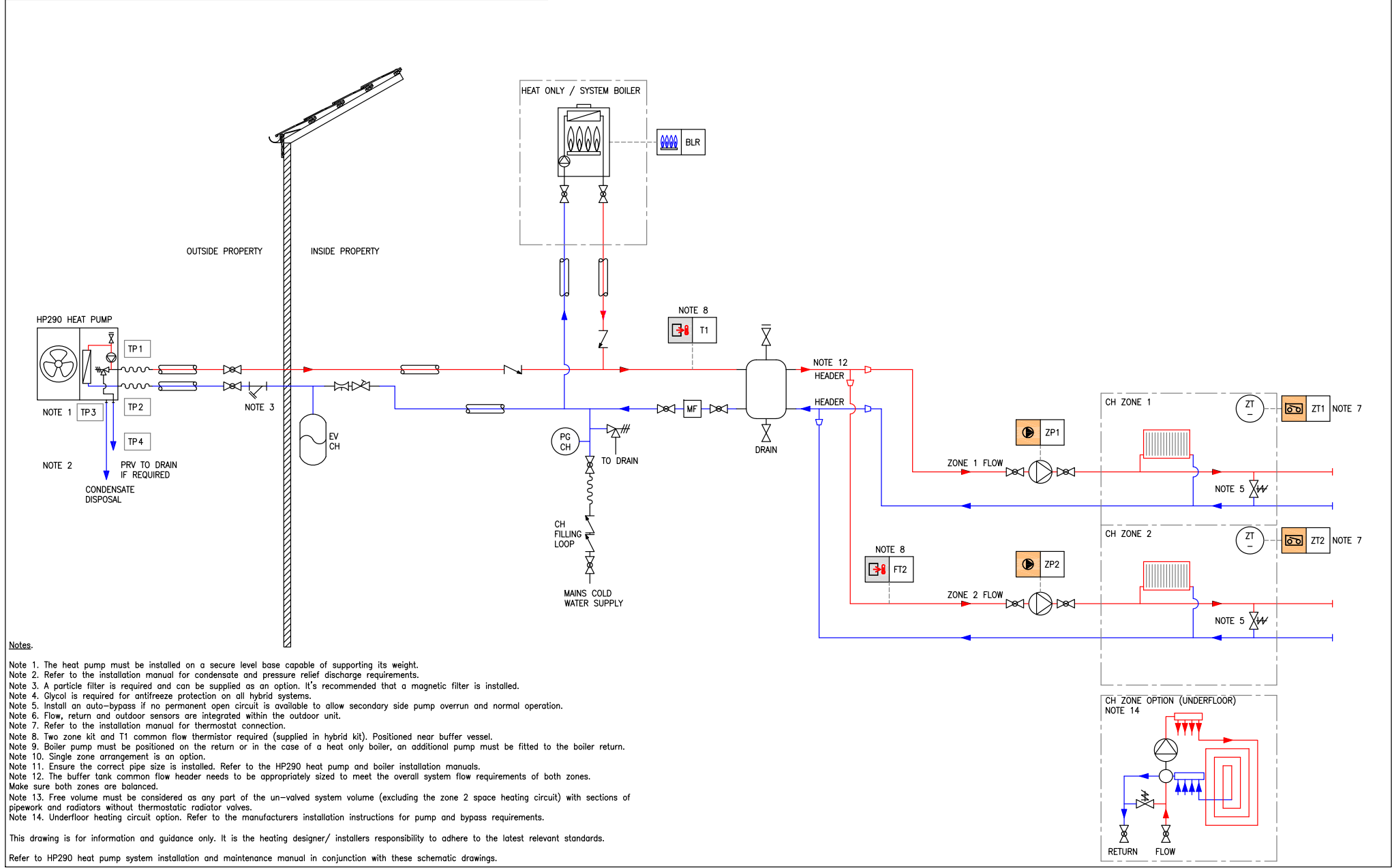

Notes.

Note 1. The heat pump must be installed on a secure level base capable of supporting its weight.
 Note 2. Refer to the installation manual for condensate and pressure relief discharge requirements.
 Note 3. A particle filter is required and can be supplied as an option. It's recommended that a magnetic filter is installed.
 Note 4. Glycol is required for antifreeze protection on all hybrid systems.
 Note 5. Install an auto-bypass if no permanent open circuit is available to allow secondary side pump overrun and normal operation.
 Note 6. Flow, return and outdoor sensors are integrated within the outdoor unit.
 Note 7. Refer to the installation manual for thermostat connection.
 Note 8. Two zone kit and T1 common flow thermistor required (supplied in hybrid kit). Positioned near buffer vessel.
 Note 9. Boiler pump must be positioned on the return or in the case of a heat only boiler, an additional pump must be fitted to the boiler return.
 Note 10. Single zone arrangement is an option.
 Note 11. Ensure the correct pipe size is installed. Refer to the HP290 heat pump and boiler installation manuals.
 Note 12. The buffer tank common flow header needs to be appropriately sized to meet the overall system flow requirements of both zones. Make sure both zones are balanced.
 Note 13. Free volume must be considered as any part of the un-valved system volume (excluding the zone 2 space heating circuit) with sections of pipework and radiators without thermostatic radiator valves.
 Note 14. Underfloor heating circuit option. Refer to the manufacturers installation instructions for pump and bypass requirements.

This drawing is for information and guidance only. It is the heating designer/ installers responsibility to adhere to the latest relevant standards.
 Refer to HP290 heat pump system installation and maintenance manual in conjunction with these schematic drawings.

CONNECTION POINT LIST					
TP No	DESCRIPTION	SIZE 4.5-6kW	SIZE 8-14kW	MATERIAL	TYPE
1	HEAT PUMP FLOW	1" BSP	1. 1/4" BSP	BRASS	BSP MALE
2	HEAT PUMP RETURN	1" BSP	1. 1/4" BSP	BRASS	BSP MALE
3	HEAT PUMP CONDENSATE DISPOSAL	32MM OD	32MM OD	PLASTIC	BARBED SPIGOT
4	PRESSURE RELIEF VALVE (PRV)	9MM ID	9MM ID	PVC	HOSE

Figure 15. HP290 + System Boiler + DHW + Two Zones (Bivalent System)

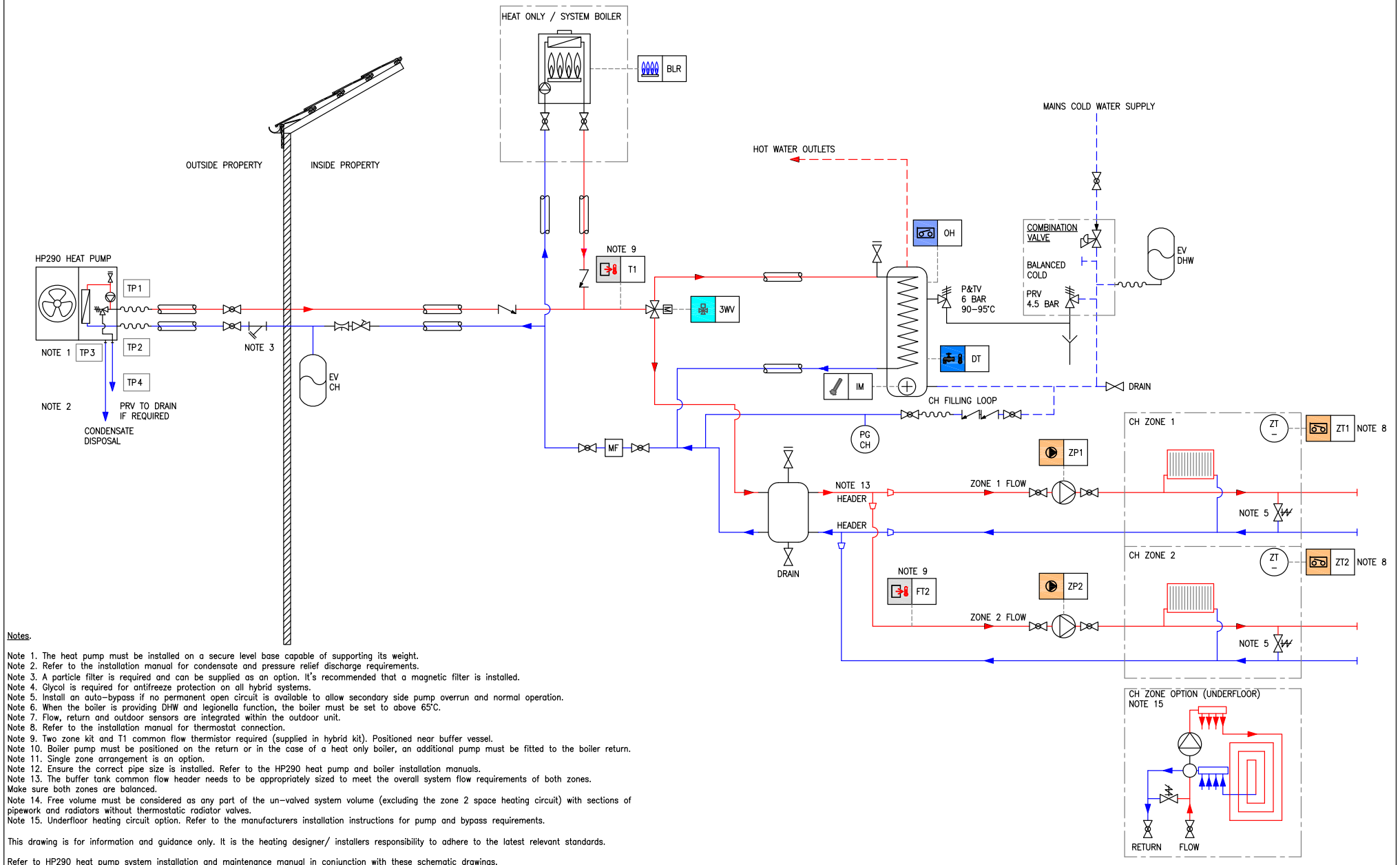

- Notes.**
- Note 1. The heat pump must be installed on a secure level base capable of supporting its weight.
 - Note 2. Refer to the installation manual for condensate and pressure relief discharge requirements.
 - Note 3. A particle filter is required and can be supplied as an option, it's recommended that a magnetic filter is installed.
 - Note 4. Glycol is required for antifreeze protection on all hybrid systems.
 - Note 5. Install an auto-bypass if no permanent open circuit is available to allow secondary side pump overrun and normal operation.
 - Note 6. When the boiler is providing DHW and legionella function, the boiler must be set to above 65°C.
 - Note 7. Flow, return and outdoor sensors are integrated within the outdoor unit.
 - Note 8. Refer to the installation manual for thermostat connection.
 - Note 9. Two zone kit and T1 common flow thermistor required (supplied in hybrid kit). Positioned near buffer vessel.
 - Note 10. Boiler pump must be positioned on the return or in the case of a heat only boiler, an additional pump must be fitted to the boiler return.
 - Note 11. Single zone arrangement is an option.
 - Note 12. Ensure the correct pipe size is installed. Refer to the HP290 heat pump and boiler installation manuals.
 - Note 13. The buffer tank common flow header needs to be appropriately sized to meet the overall system flow requirements of both zones. Make sure both zones are balanced.
 - Note 14. Free volume must be considered as any part of the un-valved system volume (excluding the zone 2 space heating circuit) with sections of pipework and radiators without thermostatic radiator valves.
 - Note 15. Underfloor heating circuit option. Refer to the manufacturers installation instructions for pump and bypass requirements.

This drawing is for information and guidance only. It is the heating designer/ installers responsibility to adhere to the latest relevant standards.
 Refer to HP290 heat pump system installation and maintenance manual in conjunction with these schematic drawings.

CONNECTION POINT LIST					
TP No	DESCRIPTION	SIZE 4.5-6kW	SIZE 8-14kW	MATERIAL	TYPE
1	HEAT PUMP FLOW	1" BSP	1. 1/4" BSP	BRASS	BSP MALE
2	HEAT PUMP RETURN	1" BSP	1. 1/4" BSP	BRASS	BSP MALE
3	HEAT PUMP CONDENSATE DISPOSAL	32MM OD	32MM OD	PLASTIC	BARBED SPIGOT
4	PRESSURE RELIEF VALVE (PRV)	9MM ID	9MM ID	PVC	HOSE
5	CYLINDER HEAT PUMP FLOW	28MM	28MM	BRASS	COMPRESSION
6	CYLINDER HEAT PUMP RETURN	28MM	28MM	BRASS	COMPRESSION
7	ZONE 1 FLOW	28MM	28MM	BRASS	COMPRESSION
8	ZONE 1 RETURN	28MM	28MM	BRASS	COMPRESSION
9	ZONE 2 FLOW	28MM	28MM	BRASS	COMPRESSION
10	ZONE 2 RETURN	28MM	28MM	BRASS	COMPRESSION

Figure 16. HP290 + System Boiler + Two Zone Pre-plumbed Cylinder with Integrated Buffer (Bivalent System)

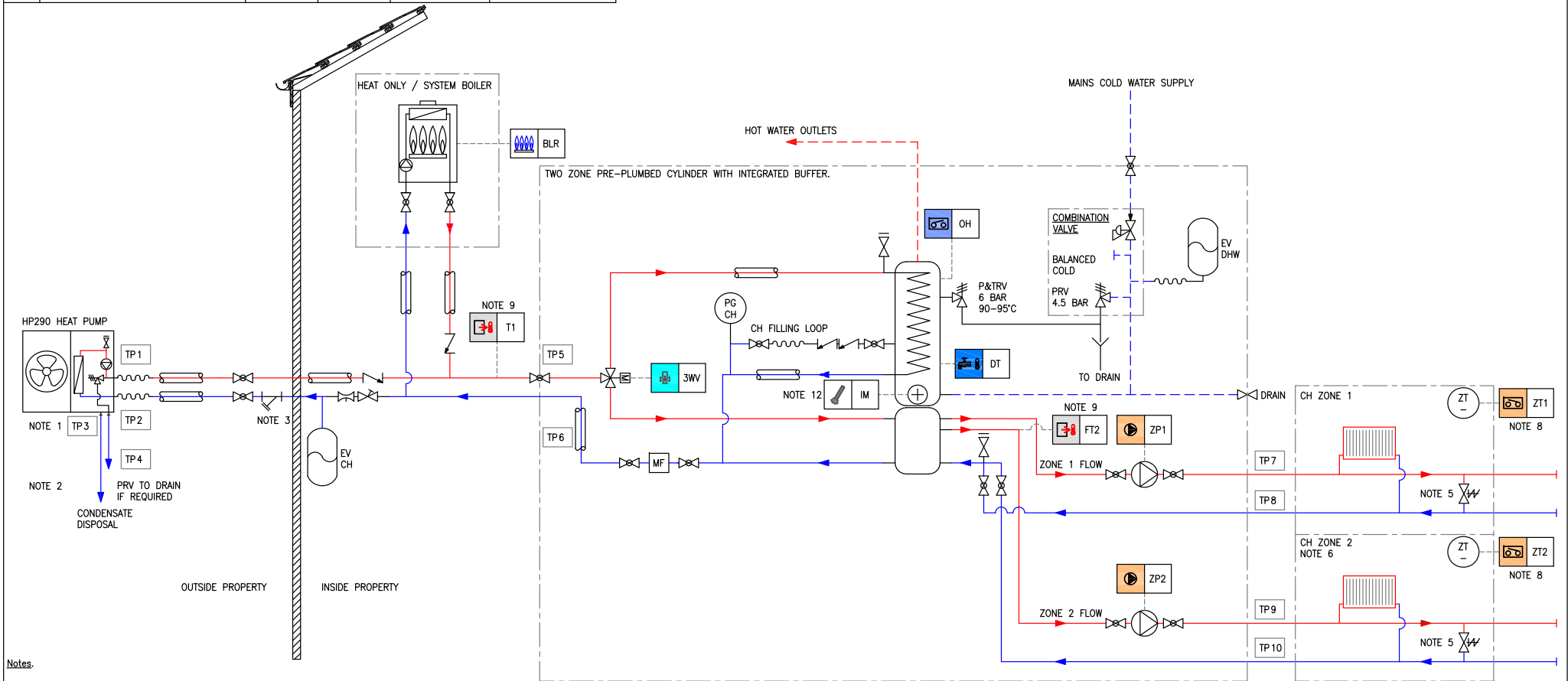

- Notes:**
- Note 1. The heat pump must be installed on a secure level base capable of supporting its weight.
 - Note 2. Refer to the installation manual for condensate and pressure relief discharge requirements.
 - Note 3. A particle filter is required and can be supplied as an option. It's recommended that a magnetic filter is installed.
 - Note 4. Glycol is required for antifreeze protection on oil hybrid systems.
 - Note 5. Install an auto-bypass if no permanent open circuit is available to allow secondary side pump overrun and normal operation.
 - Note 6. When the boiler is providing DHW and legionella function, the boiler must be set to above 65°C.
 - Note 7. Flow, return and outdoor sensors are integrated within the outdoor unit.
 - Note 8. Refer to the installation manual for thermostat connection.
 - Note 9. Two zone kit and T1 common flow thermostat required (supplied in hybrid kit). Positioned near buffer vessel.
 - Note 10. Boiler pump must be positioned on the return or in the case of a heat only boiler, an additional pump must be fitted to the boiler return.
 - Note 11. Single zone arrangement is an option.
 - Note 12. Ensure the correct pipe size is installed. Refer to the HP290 heat pump and boiler installation manuals.
 - Note 13. Free volume must be considered as any part of the un-valved system volume (excluding the zone 2 space heating circuit) with sections of pipework and radiators without thermostatic radiator valves.
 - Note 14. Underfloor heating circuit option. Refer to the manufacturers installation instructions for pump and bypass requirements.

This drawing is for information and guidance only. It is the heating designer/ installers responsibility to adhere to the latest relevant standards.

Refer to HP290 heat pump system installation and maintenance manual in conjunction with these schematic drawings.

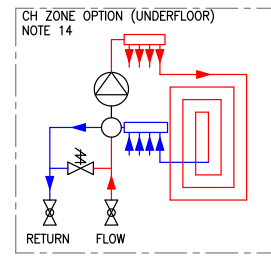

CONNECTION POINT LIST					
TP No	DESCRIPTION	SIZE 4.5-6kW	SIZE 8-14kW	MATERIAL	TYPE
1	HEAT PUMP FLOW	1" BSP	1. 1/4" BSP	BRASS	BSP MALE
2	HEAT PUMP RETURN	1" BSP	1. 1/4" BSP	BRASS	BSP MALE
3	HEAT PUMP CONDENSATE DISPOSAL	32MM OD	32MM OD	PLASTIC	BARBED SPIGOT
4	PRESSURE RELIEF VALVE (PRV)	9MM ID	9MM ID	PVC	HOSE

Figure 17. Hydraulically separated HP290 + System Boiler + DHW + Two Zones (Bivalent System)

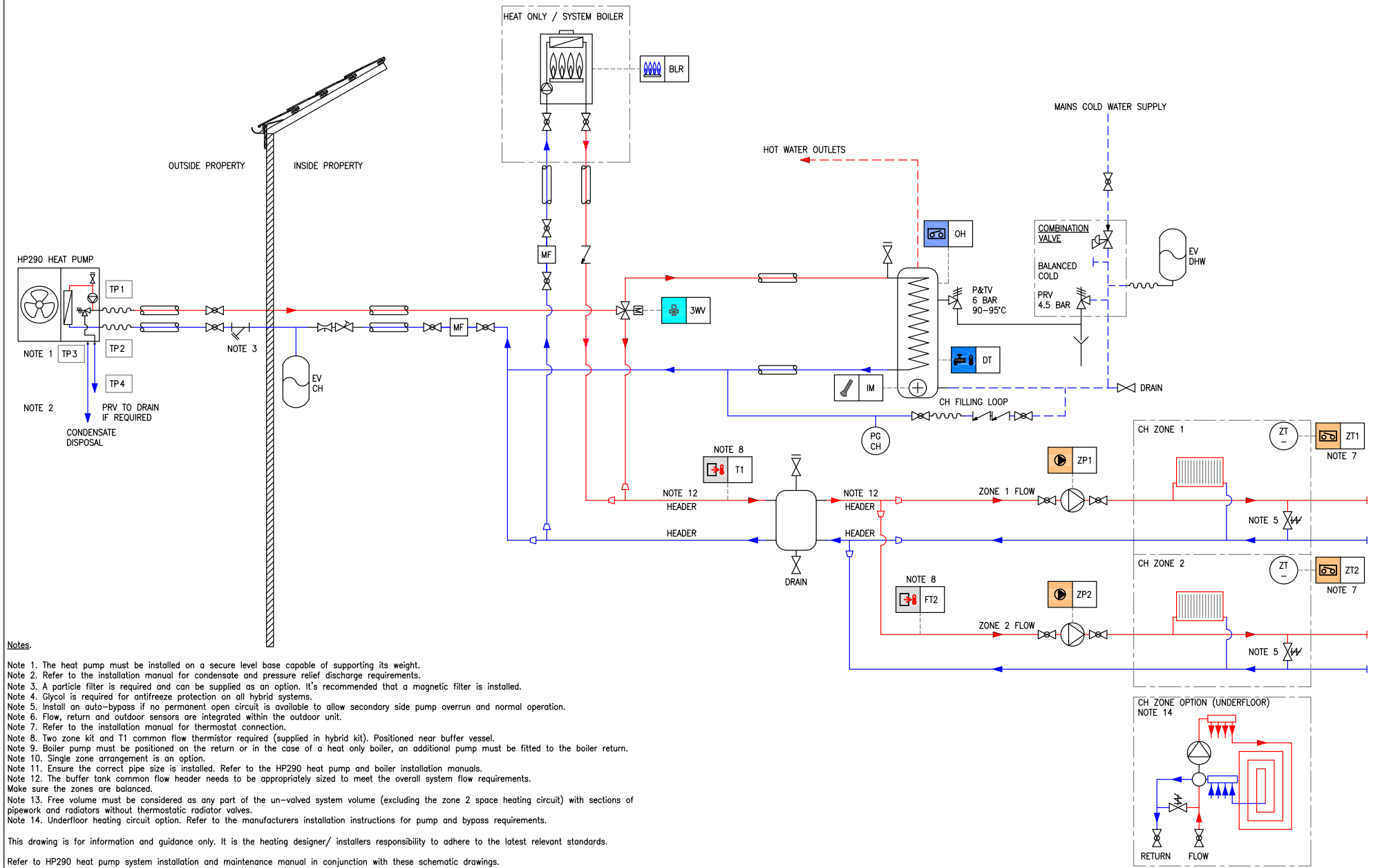

CONNECTION POINT LIST					HEADER SIZE GUIDE		
TP No	DESCRIPTION	SIZE 4.5-6kW	SIZE 8-14kW	MATERIAL	TYPE	HP290 HEAT PUMP	HEADER SIZE (mm)
1	HEAT PUMP FLOW	1" BSP	1. 1/4" BSP	BRASS	BSP MALE	2 x 4.5kW	28 OD (26.2 ID)
2	HEAT PUMP RETURN	1" BSP	1. 1/4" BSP	BRASS	BSP MALE	2 x 6kW OR 2 x 8kW	35 OD (32.6 ID)
3	HEAT PUMP CONDENSATE DISPOSAL	32MM OD	32MM OD	PLASTIC	BARBED SPIGOT	2 x 10kW OR 2 x 12kW	42 OD (39.6 ID)
4	PRESSURE RELIEF VALVE (PRV)	9MM ID	9MM ID	PVC	HOSE	2 x 14kW	54 OD (51.6 ID)

Figure 18. HP290 Heat Only Cascade + Decoupler with Two Zones

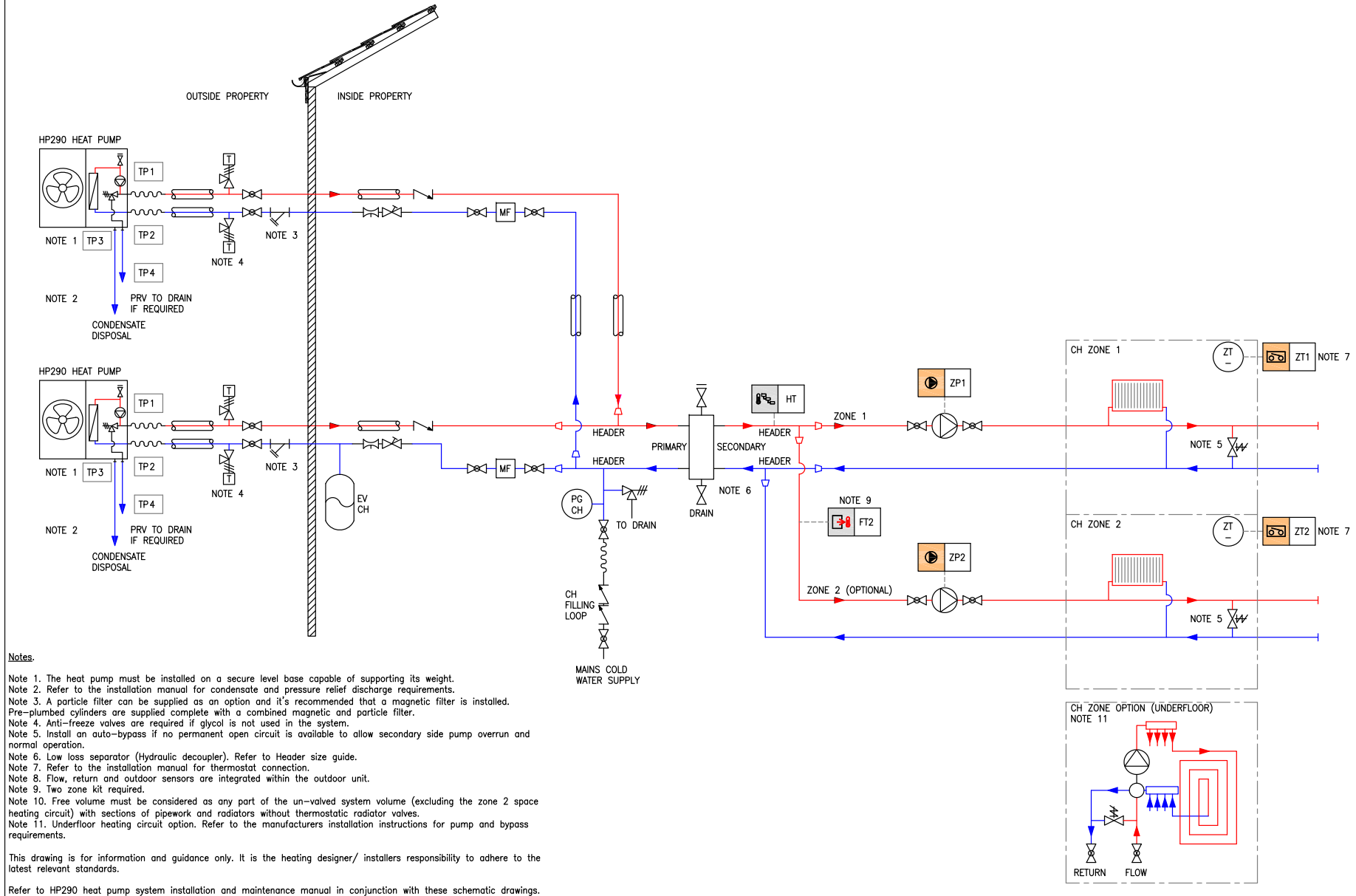

CONNECTION POINT LIST						HEADER SIZE GUIDE	
TP No	DESCRIPTION	SIZE 4.5-6kW	SIZE 8-14kW	MATERIAL	TYPE	HP290 HEAT PUMP	HEADER SIZE (mm)
1	HEAT PUMP FLOW	1" BSP	1. 1/4" BSP	BRASS	BSP MALE	2 x 4.5kW	28 OD (26.2 ID)
2	HEAT PUMP RETURN	1" BSP	1. 1/4" BSP	BRASS	BSP MALE	2 x 6 OR 2 x 8kW	35 OD (32.6 ID)
3	HEAT PUMP CONDENSATE DISPOSAL	32MM OD	32MM OD	PLASTIC	BARBED SPIGOT	2 x 10 OR 2 x 12kW	42 OD (39.6 ID)
4	PRESSURE RELIEF VALVE (PRV)	9MM ID	9MM ID	PVC	HOSE	2 x 14kW	54 OD (51.6 ID)

Figure 19. HP290 Cascade + 3rd Party DHW Cylinder + Cylinder + Decoupler with Two Zones

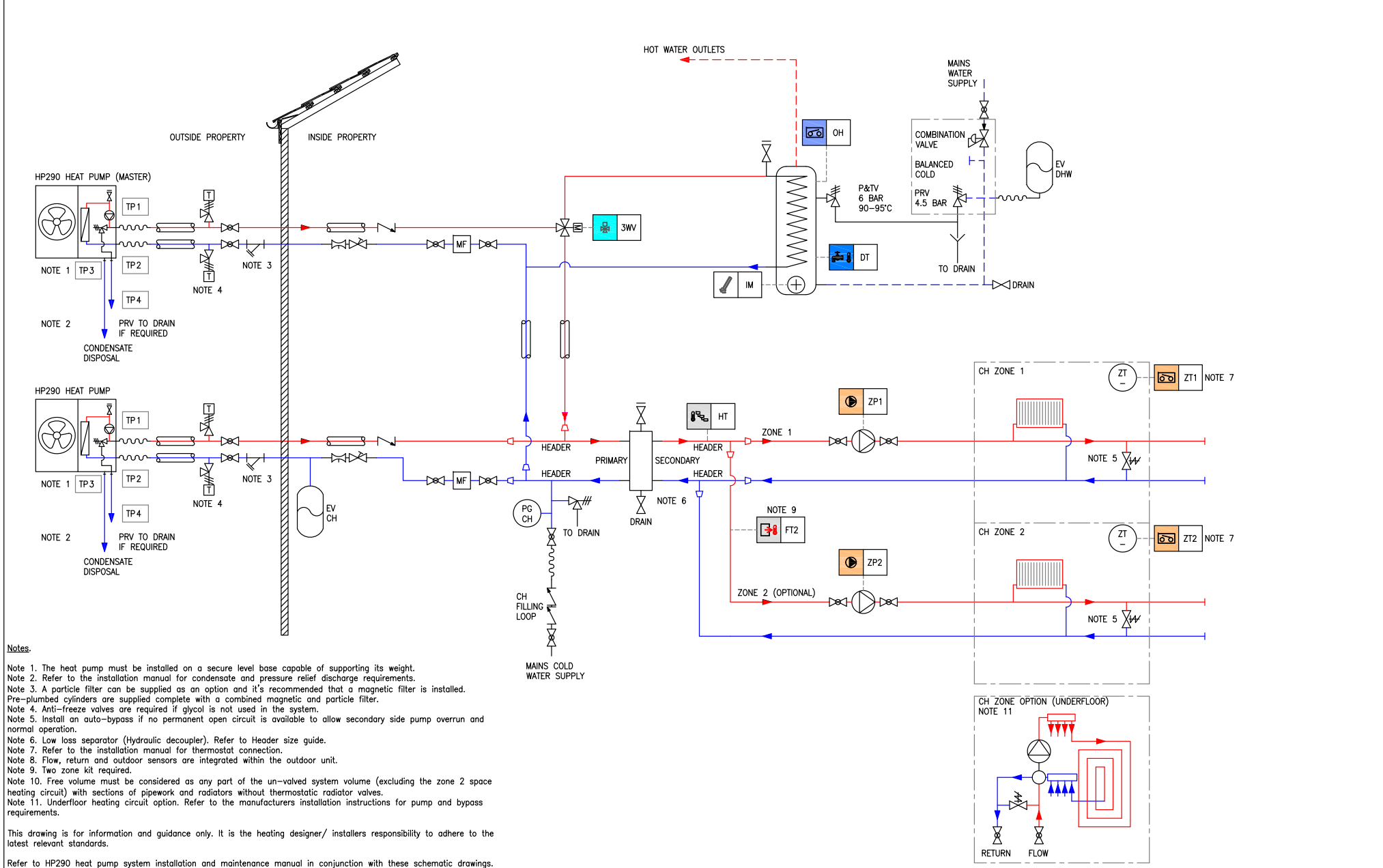

CONNECTION POINT LIST					
TP No	DESCRIPTION	SIZE 4.5-6kW	SIZE 8-14kW	MATERIAL	TYPE
1	HEAT PUMP FLOW	1" BSP	1. 1/4" BSP	BRASS	BSP MALE
2	HEAT PUMP RETURN	1" BSP	1. 1/4" BSP	BRASS	BSP MALE
3	HEAT PUMP CONDENSATE DISPOSAL	32MM OD	32MM OD	PLASTIC	BARBED SPIGOT
4	PRESSURE RELIEF VALVE (PRV)	9MM ID	9MM ID	PVC	HOSE

Figure 20. HP290 Cascade + 3rd Party DHW Cylinder + Multi-Port Decoupler with Two Zones

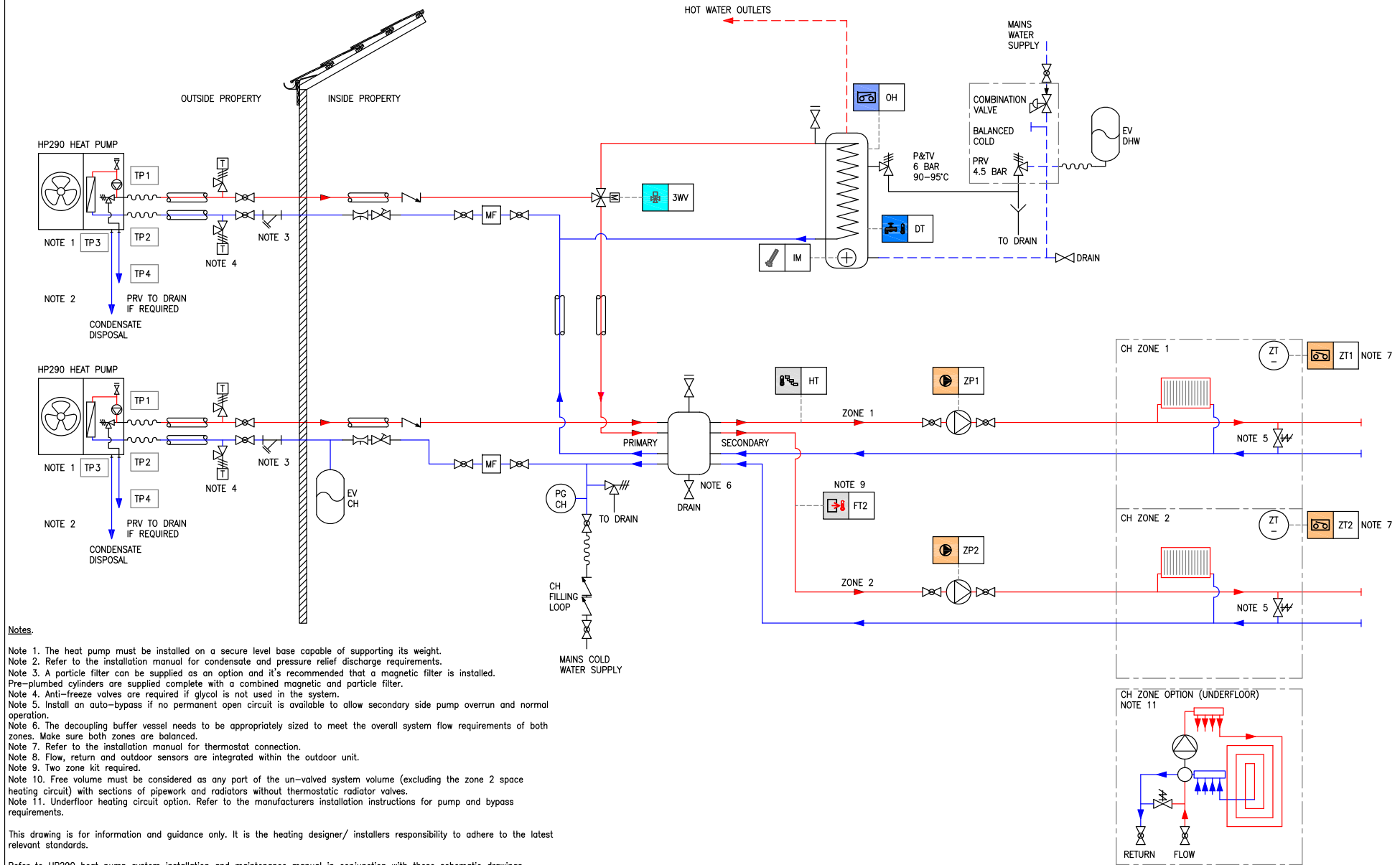

Notes.

- Note 1. The heat pump must be installed on a secure level base capable of supporting its weight.
- Note 2. Refer to the installation manual for condensate and pressure relief discharge requirements.
- Note 3. A particle filter can be supplied as an option and it's recommended that a magnetic filter is installed. Pre-plumbed cylinders are supplied complete with a combined magnetic and particle filter.
- Note 4. Anti-freeze valves are required if glycol is not used in the system.
- Note 5. Install an auto-bypass if no permanent open circuit is available to allow secondary side pump overrun and normal operation.
- Note 6. The decoupling buffer vessel needs to be appropriately sized to meet the overall system flow requirements of both zones. Make sure both zones are balanced.
- Note 7. Refer to the installation manual for thermostat connection.
- Note 8. Flow, return and outdoor sensors are integrated within the outdoor unit.
- Note 9. Two zone kit required.
- Note 10. Free volume must be considered as any part of the un-valved system volume (excluding the zone 2 space heating circuit) with sections of pipework and radiators without thermostatic radiator valves.
- Note 11. Underfloor heating circuit option. Refer to the manufacturers installation instructions for pump and bypass requirements.

This drawing is for information and guidance only. It is the heating designer/ installers responsibility to adhere to the latest relevant standards.

Refer to HP290 heat pump system installation and maintenance manual in conjunction with these schematic drawings.

CONNECTION POINT LIST					
TP No	DESCRIPTION	SIZE 4.5-6kW	SIZE 8-14kW	MATERIAL	TYPE
1	HEAT PUMP FLOW	1" BSP	1. 1/4" BSP	BRASS	BSP MALE
2	HEAT PUMP RETURN	1" BSP	1. 1/4" BSP	BRASS	BSP MALE
3	HEAT PUMP CONDENSATE DISPOSAL	32MM OD	32MM OD	PLASTIC	BARBED SPIGOT
4	PRESSURE RELIEF VALVE (PRV)	9MM ID	9MM ID	PVC	HOSE

Figure 21. HP290 Heat Only Cascade + Multi-Port Decoupler with Two Zones

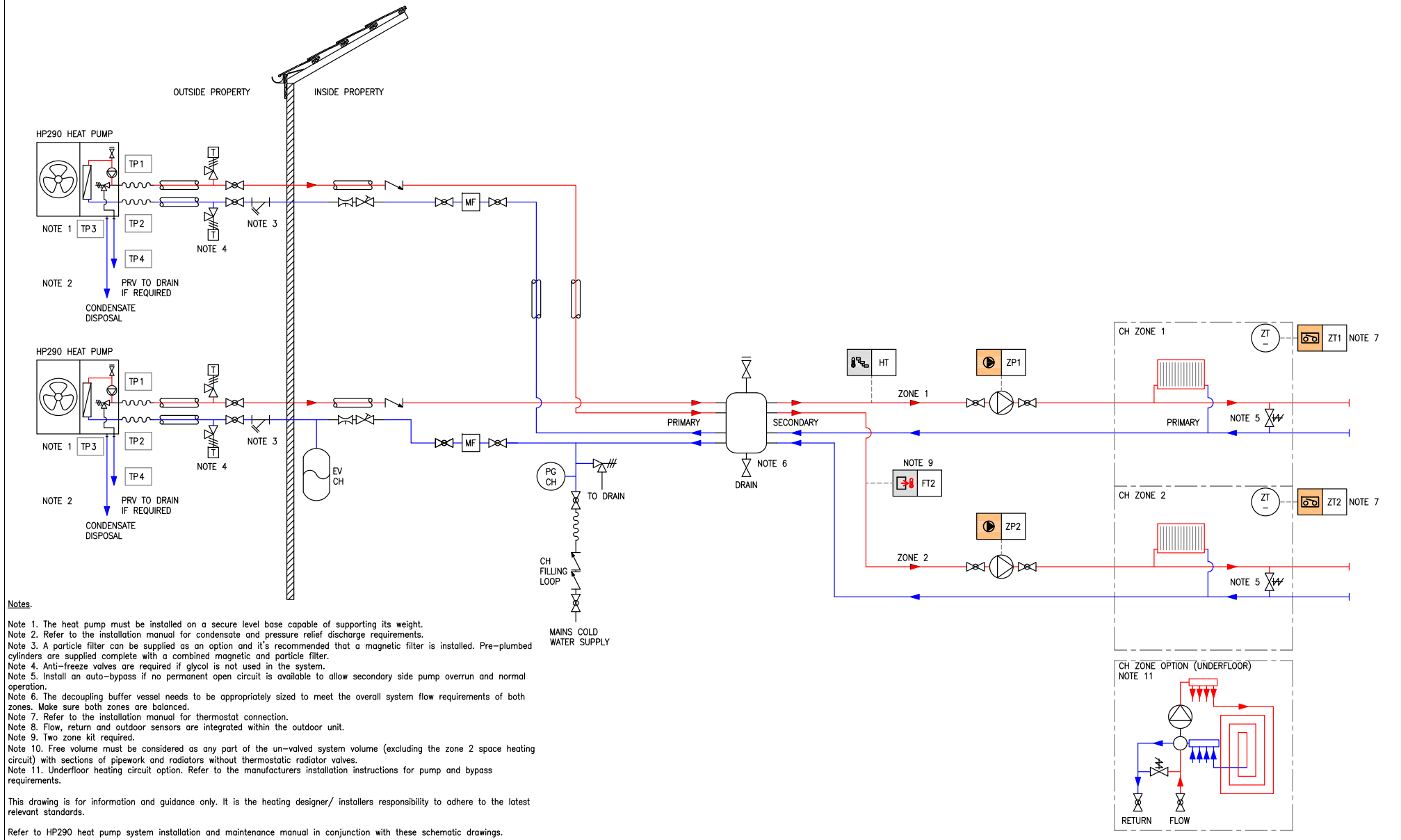

Notes.

Note 1. The heat pump must be installed on a secure level base capable of supporting its weight.
 Note 2. Refer to the installation manual for condensate and pressure relief discharge requirements.
 Note 3. A particle filter can be supplied as an option and it's recommended that a magnetic filter is installed. Pre-plumbed cylinders are supplied complete with a combined magnetic and particle filter.
 Note 4. Anti-freeze valves are required if glycol is not used in the system.
 Note 5. Install an auto-bypass if no permanent open circuit is available to allow secondary side pump overrun and normal operation.
 Note 6. The decoupling buffer vessel needs to be appropriately sized to meet the overall system flow requirements of both zones. Make sure both zones are balanced.
 Note 7. Refer to the installation manual for thermostat connection.
 Note 8. Flow, return and outdoor sensors are integrated within the outdoor unit.
 Note 9. Two zone kit required.
 Note 10. Free volume must be considered as any part of the un-valved system volume (excluding the zone 2 space heating circuit) with sections of pipework and radiators without thermostatic radiator valves.
 Note 11. Underfloor heating circuit option. Refer to the manufacturers installation instructions for pump and bypass requirements.

This drawing is for information and guidance only. It is the heating designer/ installers responsibility to adhere to the latest relevant standards.

Refer to HP290 heat pump system installation and maintenance manual in conjunction with these schematic drawings.

CONNECTION POINT LIST					
TP No	DESCRIPTION	SIZE 4.5-6kW	SIZE 8-14kW	MATERIAL	TYPE
1	HEAT PUMP FLOW	1" BSP	1. 1/4" BSP	BRASS	BSP MALE
2	HEAT PUMP RETURN	1" BSP	1. 1/4" BSP	BRASS	BSP MALE
3	HEAT PUMP CONDENSATE DISPOSAL	32MM OD	32MM OD	PLASTIC	BARBED SPIGOT
4	PRESSURE RELIEF VALVE (PRV)	9MM ID	9MM ID	PVC	HOSE

Figure 22. HP290 + Pre-plumbed Lite Heat Pump Cylinder + 2 Zone Valves

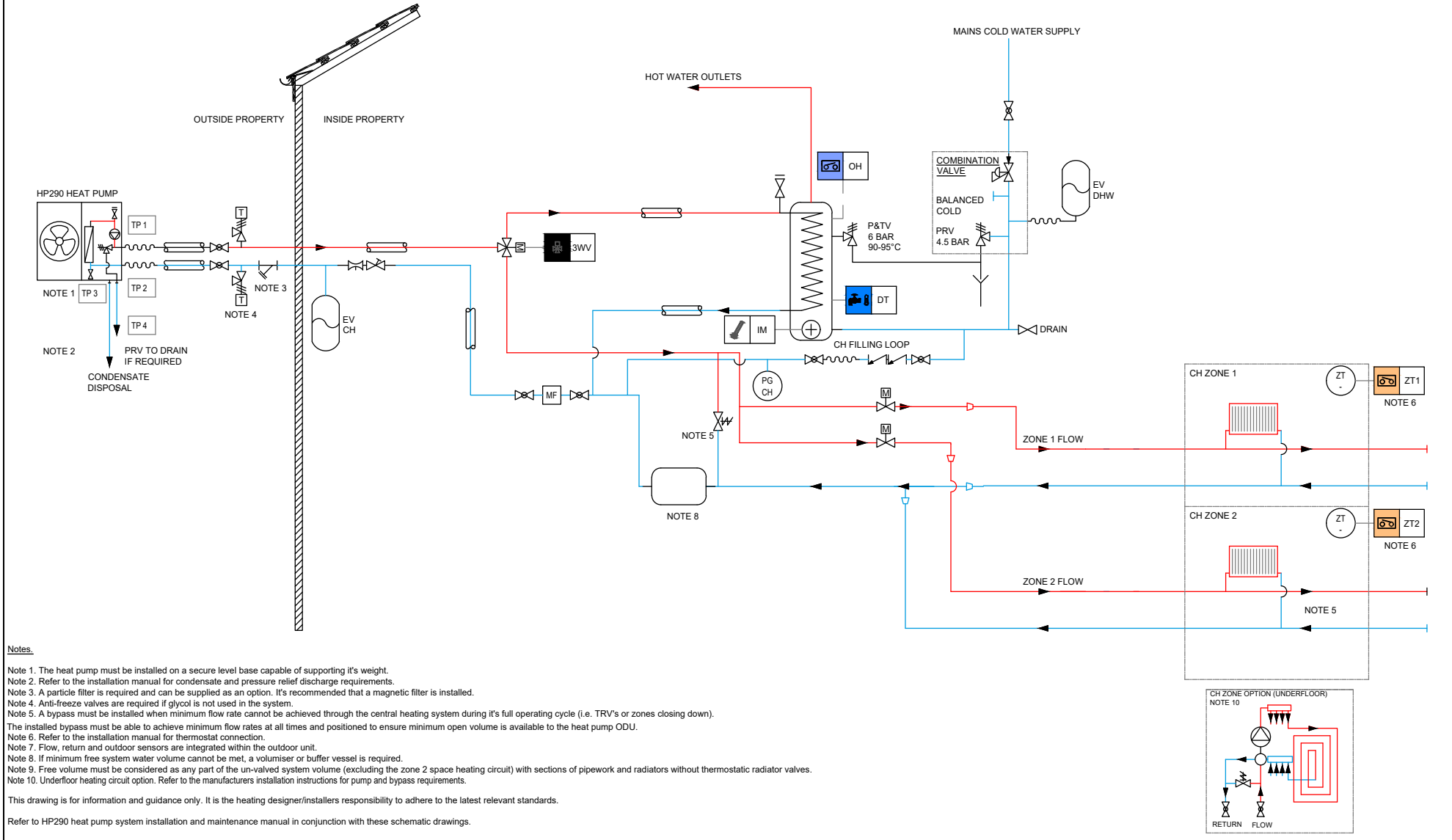

At Ideal Heating we take our environmental impact seriously, therefore when installing any Ideal Heating product please make sure to dispose of any previous appliance in an environmentally conscious manner. Households can contact their local authority to find out how. See <https://www.gov.uk/managing-your-waste-an-overview> for guidance on how to efficiently recycle your business waste.



Technical Training

Our Expert Academy offer a range of training options designed and delivered by our experts in heating. For details please contact: expert-academy.co.uk

Ideal Boilers Ltd., pursues a policy of continuing improvement in the design and performance of its products. The right is therefore reserved to vary specification without notice.

Ideal is a trademark of Ideal Boilers.

Registered Office

Ideal Boilers Ltd., National Avenue, Hull, East Yorkshire, HU5 4JB

Tel 01482 492251 Fax 01482 448858

Registration No. London 322 137

EU Authorised Representative:

Atlantic SFDT

44 Boulevard des Etats-Unis, 85 000 La Roche-Sur-Yon, France

+33 (0)2 51 44 34 34

Ideal Technical Helpline: 01482 498663

Ideal Consumer Helpline: 01482 498660

Ideal Parts: 01482 498665

idealheating.com

ROI Installer Helpline: 00353 (0)1 961 7700

service@idealenergy.ie

ideal
HEATING