



# INSTALLATION & SERVICING

**LOGIC HEAT<sup>2</sup>  
H12 H15 H18 H24 H30**

When replacing any part on this appliance, use only spare parts that you can be assured conform to the safety and performance specification that we require. Do not use reconditioned or copy parts that have not been clearly authorised by Ideal Heating.

For the very latest copy of literature for specification and maintenance practices visit our website [idealheating.com](http://idealheating.com) where you can download the relevant information in PDF format.



## ERP DATA

	SYMBOL	UNITS	MODEL				
			12	15	18	24	30
Condensing Boiler	n/a	n/a	yes	yes	yes	yes	yes
Low Temperature Boiler	n/a	n/a	no	no	no	no	no
B1 Boiler	n/a	n/a	no	no	no	no	no
Cogeneration Space Heater	n/a	n/a	no	no	no	no	no
Equipped with a Supplementary Heater	n/a	n/a	no	no	no	no	no
Combination Heater	n/a	n/a	no	no	no	no	no
<b>Nominal Heat Output for Space Heating</b>							
Full Load	P4	kW	12.1	15.1	18.1	24.3	30.3
Part Load	P1	kW	3.9	4.9	5.8	7.8	9.8
<b>Auxiliary Electricity Consumption</b>							
Full Load	elmax	kW	0.016	0.022	0.025	0.046	0.050
Part Load	elmin	kW	0.011	0.017	0.004	0.013	0.012
Standby	PSB	kW	0.002	0.003	0.002	0.002	0.002
<b>Seasonal Space Heating Energy Efficiency</b>							
Full Load	$\eta_4$	%	90.0	90.0	89.8	90.0	89.6
Part Load	$\eta_1$	%	97.9	97.8	98.5	98.6	98.2
Standby Loss	Pstby	kW	0.05	0.05	0.05	0.05	0.05
Ignition	Pign	kW	0	0	0	0	0
<b>Emissions</b>							
NOx (Gross)	NOx, pond Hs	mg/kWh	10	21	24	28	24
Annual Energy Consumption	QHE	GJ	38	47	55	75	93
Sound Power Level, Indoors	LWA	dB	36	42	44	50	50

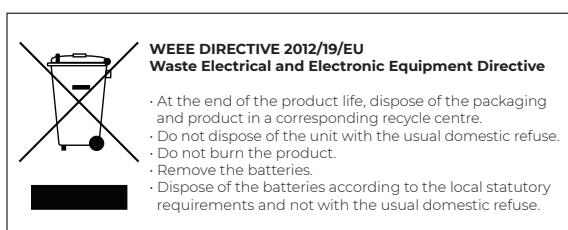

The code of practice for the installation, commissioning & servicing of central heating systems



# PRODUCT FICHE

## LOGIC HEAT<sup>2</sup> H BOILER Ideal Heating ERP DATA

	SYMBOL	UNITS	MODEL				
			12	15	18	24	30
Condensing boiler			Yes				
Seasonal space heating efficiency class			A				
Rated heat output		kW	12	15	18	24	30
Seasonal space heating energy efficiency	$\eta_s$	%	93	93	93	94	93
Annual energy consumption	$Q_{HE}$	GJ	38	47	55	75	93
Sound power level, indoors	LWA	dB	36	42	44	50	50

<b>Seasonal Space Heating Energy Efficiency of the Boiler</b>								<b>94%</b> <sup>*/%</sup>	<b>A</b>
<b>Temperature control (from fiche of temperature control)</b>								%	<b>B</b>
<i>Class I</i>	<i>Class II</i>	<i>Class III</i>	<i>Class IV</i>	<i>Class V</i>	<i>Class VI</i>	<i>Class VII</i>	<i>Class VIII</i>		
1%	2%	1.5%	2%	3%	4%	3.5%	5%		

### Solar Contribution (from fiche of solar device)

Collector Size  
(in m<sup>2</sup>)

Tank Volume  
(in m<sup>3</sup>)

Collector Efficiency  
(in %)

Tank rating  
A\* = 0.95  
A = 0.91  
B = 0.86  
C = 0.83  
D-G = 0.81

= ('III' x  + 'IV' x ) x 0.9 x (  / 100 x  ) =  % **C**

Seasonal Space Heating Energy Efficiency of Package

**TOTAL: A+B+C=**

 %

### Seasonal Space Heating Energy Efficiency Class of Package

<input style="width: 30px; height: 30px;" type="text"/>	<input style="width: 30px; height: 30px;" type="text"/>	<input style="width: 30px; height: 30px;" type="text"/>	<input style="width: 30px; height: 30px;" type="text"/>	<input style="width: 30px; height: 30px;" type="text"/>	<input style="width: 30px; height: 30px;" type="text"/>	<input style="width: 30px; height: 30px;" type="text"/>	<input style="width: 30px; height: 30px;" type="text"/>	<input style="width: 30px; height: 30px;" type="text"/>	<input style="width: 30px; height: 30px;" type="text"/>
<b>G</b>	<b>F</b>	<b>E</b>	<b>D</b>	<b>C</b>	<b>B</b>	<b>A</b>	<b>A+</b>	<b>A++</b>	<b>A+++</b>
< 30%	≥ 30%	≥ 34%	≥ 36%	≥ 75%	≥ 82%	≥ 90%	≥ 98%	≥ 125%	≥ 150%

The energy efficiency of the package of products provided for in this document may not correspond to its actual energy efficiency once installed in a building, as the efficiency is influenced by further factors such as heat loss in the products in relation to the building size and its characteristics

## NOTES FOR THE INSTALLER

For any technical queries please ring the Ideal installer helpline : 01482 498663

### **BOILER RESTART PROCEDURE -**

**Press the RESTART button. The boiler will repeat the ignition sequence if a heat demand is present.**

## DEFINITIONS



**WARNING:** Risk of injury or death



**CAUTION:** Risk of damage to objects



**IMPORTANT:** Important information

## Table of Acronyms

**CH** - Central Heating

**DHW** - Domestic Hot Water

**TRV** - Thermostatic Radiator Valve

**PRV** - Pressure Relief Valve

**IE** - Ireland

**ETCI** - Electro-Technical Council of Ireland

**BS** - British Standard

**WRAS** - Water Regulations Advisory Scheme

**SAP** - Standard Assessment Procedure

**IET** - Institution of Engineering and Technology

**UKCA** - UK Conformity Assessed

**IoT** - Internet of Things

**RHS** - Right Hand Side

**LHS** - Left Hand Side

**PCB** - Printed Circuit Board



# CONTENTS

<p>Section 1 - General ..... 6</p> <p>1.1 Introduction ..... 8</p> <p>1.2 Operation ..... 8</p> <p>1.3 Safe Handling ..... 8</p> <p>1.4 Optional Accessories ..... 8</p> <p>1.5 Safety ..... 8</p> <p>1.6 Safe Handling of Substances ..... 9</p> <p>1.7 Location of Boiler ..... 9</p> <p>1.8 Carbon Monoxide Alarms ..... 9</p> <p>1.9 Air Supply ..... 10</p> <p>1.10 Gas Supply ..... 10</p> <p>1.11 Water Circulation System ..... 10</p> <p>1.12 Boiler Controls ..... 10</p> <p>1.13 Electrical Supply ..... 11</p> <p>1.14 Condensate Drain ..... 11</p> <p>1.15 Boiler Dimensions, Services &amp; Clearances ..... 12</p> <p>1.16 Open Vent System Requirements ..... 13</p> <p>1.17 Schematic Pipework and System Balancing ..... 13</p> <p>1.18 Low Head and Large Systems with Extensive Pipe Runs - Open Vent ..... 14</p> <p>1.19 Sealed System Requirements ..... 14</p> <p>1.20 Sealed System Requirements - Cont. .... 15</p> <p>1.21 System Balancing ..... 16</p> <p>1.22 Water Treatment ..... 16</p> <p>Section 2 - Installation ..... 17</p> <p>2.1 Boiler Assembly - Exploded View ..... 17</p> <p>2.2 Unpacking ..... 18</p> <p>2.3 Wall Mounting Template ..... 19</p> <p>2.4 Preparing the Wall ..... 19</p> <p>2.5 Fitting the Wall Mounting Plate ..... 19</p> <p>2.6 Mounting the Boiler ..... 19</p> <p>2.7 Flues and Locations ..... 20</p> <p>2.8 Flues and Locations - Cont. .... 21</p> <p>2.9 Horizontal Flue Positions ..... 22</p> <p>2.10 Vertical Flue Positions ..... 22</p> <p>2.11 Flue System Dimensions ..... 23</p> <p>2.12 Fitting the Turret ..... 23</p> <p>2.13 Cutting the Flue ..... 24</p> <p>2.14 Assembling the Vertical Flue ..... 25</p> <p>2.15 Rear Flue Outlet Kit (55/80) Assembly - Exploded View ..... 26</p> <p>2.16 Terminal Wall Seal Assembly / Positioning ..... 26</p> <p>2.17 Setting the rear flue length - Wall Thickness of 115 mm to 442 mm ..... 26</p> <p>2.18 Fitting the Wall Plate / Rear Flue Terminal Assembly ..... 27</p> <p>2.19 Mounting the Boiler - Rear Flue Outlet Kit (55/80) ..... 27</p> <p>2.20 Condensate Drain ..... 28</p> <p>2.21 Condensate Drain - Cont'd ..... 29</p> <p>2.22 Connections ..... 30</p> <p>2.23 Electrical Connections ..... 30</p> <p>2.24 Installer Wiring ..... 30</p> <p>2.25 Installer Wiring - Continued ..... 31</p> <p>2.26 Installer Wiring - Continued ..... 32</p>	<p>2.27 Installer Wiring - Continued ..... 33</p> <p>2.28 Pump Overrun - Install ..... 34</p> <p>2.29 Electrical Controls ..... 34</p> <p>2.30 Wiring Diagram ..... 35</p> <p>2.31 Commissioning and Testing ..... 36</p> <p>2.32 Initial Lighting ..... 37</p> <p>2.33 The Display ..... 38</p> <p>2.34 General Checks ..... 38</p> <p>2.35 General Checks Cont. - Water Circulation ..... 39</p> <p>2.36 Restart Procedure ..... 39</p> <p>2.37 Accessing the Installer Mode ..... 40</p> <p>2.38 Handing Over ..... 40</p> <p>Section 3 - Servicing ..... 41</p> <p>3.1 Servicing Schedule ..... 41</p> <p>3.2 Removal / Replacement of Components ..... 42</p> <p>3.3 Draining the Boiler ..... 42</p> <p>3.4 Boiler Front Panel Removal / Replacement ..... 43</p> <p>3.5 Flue Manifold Removal / Replacement ..... 43</p> <p>3.6 Fan and Venturi Assembly Removal and Cleaning ..... 44</p> <p>3.7 Burner Removal and Cleaning ..... 45</p> <p>3.8 Cleaning the Heat Exchanger ..... 45</p> <p>3.9 Ignition / Detection Electrode Replacement / Inspection ..... 46</p> <p>3.10 Cleaning the Condensate Trap ..... 46</p> <p>3.11 Flow &amp; Return Thermistor Replacement ..... 47</p> <p>3.12 Burner Injector Replacement ..... 47</p> <p>3.13 Burner Replacement ..... 47</p> <p>3.14 Spark Generator Replacement ..... 48</p> <p>3.15 Gas Control Valve Replacement ..... 48</p> <p>3.16 Condensate Trap Replacement / Cleaning ..... 49</p> <p>3.17 Flow Switch Replacement ..... 49</p> <p>3.18 Primary PCB Replacement ..... 49</p> <p>3.19 Heat Engine Replacement ..... 50</p> <p>Section 4 - Fault Finding ..... 51</p> <p>4.1 Fault Finding Main Menu ..... 51</p> <p>4.2 'L 01' - Overheat Lockout ..... 52</p> <p>4.3 'L 02' - Ignition Lockout ..... 52</p> <p>4.4 'L 06' - Flame On Before Gas Valve On ..... 53</p> <p>4.5 'F 02 or FN or LN' - Flame Loss ..... 53</p> <p>4.6 'F 03' - Fan Fault ..... 54</p> <p>4.8 Flow / Return Reversed ..... 54</p> <p>4.7 F 04 or L 04' - Flow Thermistor Fault ..... 54</p> <p>4.9 'F 05 or L 05' - Return Thermistor Fault ..... 55</p> <p>4.10 'F 06' - Outside Sensor Fault ..... 55</p> <p>4.11 No CH Operation ..... 56</p> <p>4.12 No Display ..... 57</p> <p>4.13 No DHW Operation ..... 57</p> <p>4.14 Flow / Return Differential Greater than 50°C ..... 57</p> <p>4.15 'F0 d' - No Water Flow ..... 58</p> <p>Section 5 - Spare Parts ..... 60</p> <p>Section 6 - Benchmark to Commissioning ..... 61</p>
---	---

## Section 1 - General

**Table 1 General Data**

		12	15	18	24	30
Gas Supply		2H - G20 - 20 mbar				
Gas Supply Connection		15 mm copper compression				
Injector Size	mm	4.15	4.15	4.15	4.15	4.65
Flow Connection	Central Heating	22 mm copper compression				
Return Connection	Central Heating	22 mm copper compression				
Flue Terminal Diameter	mm	100				
Average Flue Temp-Mass Flow Rate		56°C - 5g/s	56°C - 6g/s	58°C - 8g/s	63°C - 10g/s	69°C - 13g/s
CO <sub>2</sub> Content (± 0.7)	Max. CH	9.1%	9.4%	9.3%	9.3%	9.7%
	Min. CH	8.5%	8.8%	8.7%	8.4%	8.8%
Maximum Working Pressure (Sealed Systems)	bar (psi)	2.5 (36.3)				
Electrical Supply		230 V ~ 50 Hz				
Power Consumption	W	16	22	25	46	50
Fuse Rating		External : 3 A Internal : T4A HRC L250 V				
Water Content	Central Heating litre (gal)	1.2 (0.26)				
Packaged Weight	kg	25.1				
Lift Weight	kg	21.9				
Boiler Casing Size	Height mm	700				
	Width mm	395				
	Depth mm	278				

**Table 2 Performance Data - Central Heating**

Boiler Input:		12		15		18		24		30	
		Min	Max	Min	Max	Min	Max	Min	Max	Min	Max
Boiler Input 'Q' Net CV	kW	4.9	12.1	4.9	15.1	4.9	18.1	4.9	24.3	6.1	30.4
	Gross CV	5.4	13.4	5.4	16.6	5.4	20.1	5.4	27.0	6.7	33.7
Gas Consumption	m <sup>3</sup> /h	0.500	1.246	0.500	1.537	0.500	1.872	0.500	2.512	0.623	3.136
Boiler Output :											
Non Condensing 70°C Mean Water Temp.	kW	4.8	12.0	4.8	15.0	4.8	18.0	4.8	24.2	6.1	30.3
Condensing 40°C Mean Water Temp.	kW	5.1	13.0	5.1	15.9	5.1	19.1	5.1	25.6	6.4	31.0
Seasonal Efficiency* SEDBUK 2005		91.1%		91.2%		91.1%		91.2%		91.1%	
Seasonal Efficiency* SEDBUK 2009/2012		89.4%		89.4%		89.7%		89.7%		89.6%	
NOx Classification		Class 6									

\* The value is used in the UK Government's Standard Assessment Procedure (SAP) for energy rating of dwellings. The test data from which it has been calculated have been certified by a notified body.

Gas consumption is calculated using a calorific value of 38.7 MJ/m<sup>3</sup> (1038 Btu/ft<sup>3</sup>) gross or 34.9 MJ/m<sup>3</sup> (935 Btu/ft<sup>3</sup>) nett

To obtain the gas consumption at a different calorific value:

- For l/s** - divide the gross heat input (kW) by the gross C.V. of the gas (MJ/m<sup>3</sup>)
- For Btu/h** - multiply the gross heat input (kW) by 26.8
- For ft<sup>3</sup>/h** - divide the gross heat input (Btu/h) by the gross C.V. of the gas (Btu/ft<sup>3</sup>)
- For m<sup>3</sup>/h** - multiply l/s by 3.6

**C<sub>13</sub> C<sub>33</sub> C<sub>53</sub>** = A room sealed appliance designed for connection via ducts to a horizontal or vertical terminal, which admits fresh air to the burner and discharges the products of combustion to the outside through orifices which, in this case, are concentric. The fan is up stream of the combustion chamber.

**I<sub>2H</sub>** = An appliance designed for use on 2nd family gas, Group H only.

## Section 1 - General

### LOGIC HEAT<sup>2</sup> H

Natural Gas Only

BOILER SIZE	G.C. Appliance No (Benchmark No.)
12	41-860-10
15	41-860-11
18	41-860-12
24	41-860-13
30	41-860-14

Destination Country: GB

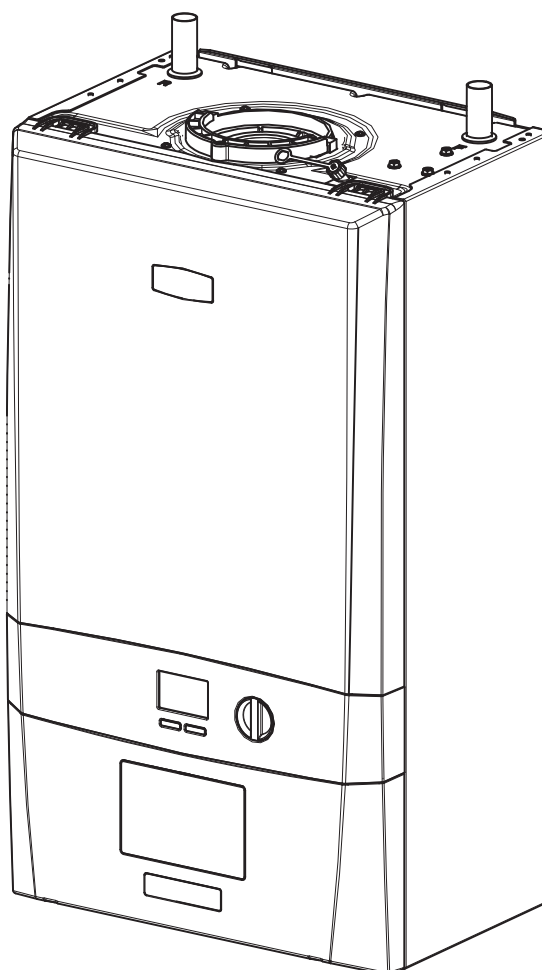

For UK, to comply with Building Regulations Part L1 (Part 6 in Scotland) the boiler should be fitted in accordance with the manufacturer's instructions. Self-certification that the boiler has been installed to comply with Building Regulations can be demonstrated by completing and signing the Benchmark Commissioning Checklist.

Before installing this boiler, read the Code of Practice sheet at the rear of this book.

#### BENCHMARK COMMISSIONING CHECKLIST DETAILS

Boiler	Page	Page
Make and model.....	7	Central heating flow temp. .... measure and record
Appliance serial no. on data badge .....	Front Cover	Central heating return temp. .... measure and record
SEDBUK No. %.....	6	<b>For combination boilers only</b>
<b>Controls</b>		Scale reducer .....
Time and temperature control to heating .....	31	..... n/a
Time and temperature control to hot water .....	31	<i>Hot water mode</i>
TRVs .....	10	Heat input.....to be calculated
Auto bypass .....	10	Max. operating burner pressure .....
Boiler interlock.....	10	..... n/a
<b>For all boilers</b>		Max. operating water pressure..... measure & record
Flushing to BS.7593.....	15	Cold water inlet temp .....
Inhibitor .....	15	..... measure & record
<i>Central heating mode</i>		Hot water outlet temp. ....
Heat input.....to be calculated		..... measure & record
Burner operating pressure .....	n/a	Water flow rate at max. setting.....
		..... measure & record
		<b>For condensing boilers only</b>
		Condensate drain.....
		.....27-28
		<b>For all boilers: Complete, sign &amp; hand over to customer</b>

NOTE TO THE INSTALLER: COMPLETE THE BENCHMARK COMMISSIONING CHECKLIST AND LEAVE THESE INSTRUCTIONS WITH APPLIANCE



For assistance call Technical Helpline 01482 498663

## Section 1 - General

### 1.1 INTRODUCTION

The **Logic Heat<sup>2</sup> H** range of boilers are wall mounted, full sequence, automatic spark ignition, low water content, fanned flue, high efficiency, condensing, heating only gas boilers.

Due to the high efficiency of the boiler a plume of water vapour will form at the terminal during operation.

A variable temperature control is fitted on the user control.

The boiler includes as standard:

- Boiler frost protection

**Notes.** The appliance must be wired with a permanent live supply, or the boiler frost protection will not operate.

The boiler warranty will be invalid if these requirements are not complied with.

The boiler casing is of white painted mild steel with a polymer front panel.

The boiler temperature control is visibly located in the control panel on the front of the boiler.

The heat exchanger is manufactured from cast aluminium.

Note that these boilers cannot be used on systems which include gravity circulation.

The boiler is suitable for connection to fully pumped open vented or sealed water systems. Adequate arrangements for completely draining the system by provision of drain cocks **MUST** be provided in the installation pipework.

Pipework from the boiler is routed upwards.

A rear flue outlet kit (55/80) is available which provides a compact installation.

#### Data Plate

The boiler model and serial number can be located on the bottom of the boiler casing, shown in Section 1.16 - Water & Gas Connection Diagram.

### 1.2 OPERATION

When there is a demand, the heating system is supplied at the selected temperature of between 30°C and 80°C.

The boiler features a comprehensive diagnostic system which gives detailed information on the boiler status when operating, and performance of key components to aid commissioning and fault finding.

### 1.3 SAFE HANDLING

This boiler may require 2 or more operatives to move it to its installation site, remove it from its packaging base and during movement into its installation location. Manoeuvring the boiler may include the use of a sack truck and involve lifting, pushing and pulling.

Caution should be exercised during these operations.

Operatives should be knowledgeable in handling techniques when performing these tasks and the following precautions should be considered:

- Grip the boiler at the base.
- Be physically capable.
- Use personal protective equipment as appropriate, e.g. gloves, safety footwear.

During all manoeuvres and handling actions, every attempt should be made to ensure the following unless unavoidable and/or the weight is light.

- Keep back straight.
- Avoid twisting at the waist.
- Avoid upper body/top heavy bending.
- Always grip with the palm of the hand.
- Use designated hand holds.
- Keep load as close to the body as possible.
- Always use assistance if required.

### 1.4 OPTIONAL ACCESSORIES

Please visit [idealheating.com](http://idealheating.com) to access the Accessories & Controls Installation Guide for this boiler.



### 1.5 SAFETY

#### Current Gas Safety (installation and use) regulations or rules in force:

The appliance is suitable only for installation in GB and should be installed in accordance with the rules in force.

In GB, the installation must be carried out by a Gas Safe Registered Engineer. It must be carried out in accordance with the relevant requirements of the:

- Gas Safety (Installation and Use) Regulations
- Appropriate Building Regulations, either The Building Regulations, The Building Regulations (Scotland), Building Regulations (Northern Ireland).
- Water Fittings Regulations or Water byelaws in Scotland.
- Current IET Wiring Regulations.

Where no specific instructions are given, reference should be made to the relevant British Standard Code of Practice.

The Boiler has been tested and certified to;

BSEN 15502-1, BSEN 15502-2, BSEN 15502-2-1, BSEN 60335-1, BSEN 60335-2-102, BSEN 55014-1 and BSEN 55014-2 for use with Natural Gas & Propane.

## Section 1 - General

Detailed recommendations are contained in the following British Standard Codes of Practice:

- BS5440:1** Flues (for gas appliances of rated input not exceeding 70 kW).
- BS5440:2** Ventilation (for gas appliances of rated input not exceeding 70 kW).
- BSEN12828** Heating Systems in buildings: Design for water based heating systems.
- BSEN12831** Heating Systems in buildings: Method for calculation of the design heat load.
- BSEN14336** Heating Systems in buildings: Installation and commissioning of water based heating systems.
- BS5546** Installation of gas hot water supplies for domestic purposes (2nd Family Gases)
- BS6798** Installation of gas fired hot water boilers of rated input not exceeding 70 kW.
- BS6891** Installation and maintenance of low pressure gas installation pipework.
- BS 7593:2019** Code of practice for the preparation, commissioning and maintenance of domestic central heating and cooling water systems.

**Health & Safety Document No. 635.**

**The Electricity at Work Regulations, 1989.**

The manufacturer's notes must NOT be taken, in any way, as overriding statutory obligations.

**IMPORTANT:** This appliance is UKCA/CE certificated for safety and performance. Do not connect external control devices directly to this appliance unless recommended in this manual or by **Ideal Heating** in writing. If in doubt, please enquire.

Unapproved control devices could invalidate the warranty of this appliance and infringe the Gas Safety Regulations.

### 1.6 SAFE HANDLING OF SUBSTANCES

No asbestos, mercury or CFCs are included in any part of the boiler or its manufacture.

### 1.7 LOCATION OF BOILER

The boiler must be installed on a flat and vertical internal wall, capable of adequately supporting the weight of the boiler and any ancillary equipment.

The boiler may be fitted on a combustible wall and insulation between the wall and the boiler is not necessary, unless required by the local authority.



**WARNING:** Rear access to the boiler is not permitted.



**CAUTION:** Do not fit the boiler outside.

### Timber Framed Buildings

Boilers installed in a timber-framed building must comply with IGE/UP7 +A 2008.

### Bathroom Installations



**CAUTION:** This appliance is IP20 rated, do not clean with jets of water.

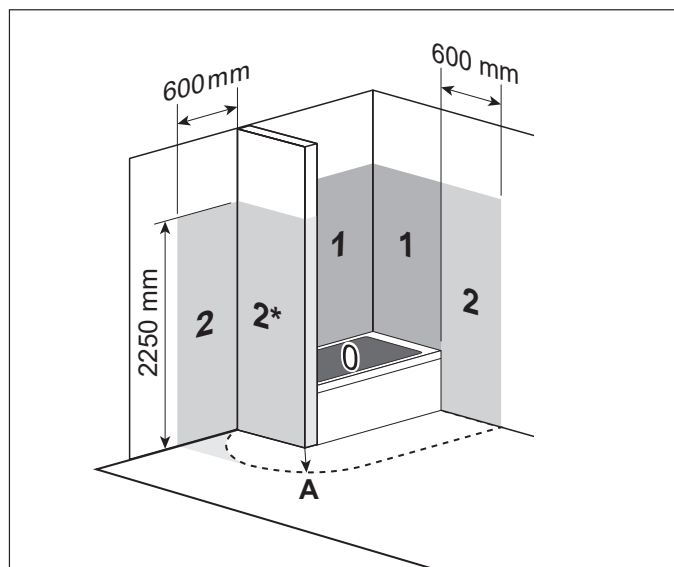

### Bathroom Installations

[0] Zone 0

[1] Zone 1

[2] Zone 2

[2\*] Without the end wall, zone 2 must extend 600 mm from the bath

[A] 600 mm radius from the bath or shower

You may install the boiler in any internal space. The installation must comply with the current IET (BS 7671) Wiring Regulations and the electrical regulations applicable in Scotland.

If the appliance is to be installed in a room containing a bath or shower then, the appliance must be installed beyond Zone 2, as detailed in BS7671.

### Compartment Installations

A boiler installed in a compartment does not require ventilation. However, A boiler installed in a compartment must provide adequate clearances for servicing.

Refer to Section  
1.15

### 1.8 CARBON MONOXIDE ALARMS

When installing a new boiler, Installers should make sure that a suitable carbon monoxide alarm is installed near to the boiler.

## Section 1 - General

**IMPORTANT:** Carbon monoxide alarms must be installed in any room that has a fixed combustion appliance.

UK Building Regulations state that a carbon monoxide alarm should be installed in the room where:

- a new or replacement fixed combustion appliance (excluding an appliance used solely for cooking) is installed in the dwelling, or
- a new or replacement fixed combustion appliance is installed in a connected space such as an integral garage.

Users and Installers should comply with the Smoke and Carbon Monoxide Alarm (Amendment) Regulations 2022 and BS EN 50291-1:2010, and all applicable local building authority regulations.

Carbon monoxide detectors should use a battery designed to operate for the working life of the detector. Carbon monoxide detectors that are connected to the main electrical supply and comply with BS EN 50291-1:2010 (Type A) may be used, as long as a sensor failure warning device is installed. All detectors should include a warning device to alert the Users when working life of the detector is scheduled to end.

### 1.9 AIR SUPPLY

It is not necessary to have an air vent in the room or internal space where the boiler is installed.

### 1.10 GAS SUPPLY

Consult the local gas supplier to establish an adequate supply of gas. Do not use existing service pipes without consulting the local gas supplier.

The gas supply must be governed with a meter.

A gas meter can only be connected by the local gas supplier or a Gas Safe Registered Engineer.

An existing meter should be checked, preferably by the gas supplier, to ensure that the meter is adequate to deal with the required gas supply rate.

It is the responsibility of the Gas Installer to size the gas installation pipework in accordance with BS6891.

Whilst the principle of the 1:1 gas valve ensures the Logic range is able to deliver its full output at inlet pressures as low as 14 mb, other gas appliances in the property may not be as tolerant. When operating pressures are found to be below the minimum meter outlet of 19 mb these should be checked to ensure this is adequate for correct and safe operation.

Allowing for the acceptable pressure loss of 1mb across the installation pipework, it can be assumed that a minimum permitted operating pressure of 18mb will be delivered to the inlet of the appliance.

(Reference BS6400-1 Clause 6.2 Pressure Absorption).

The external gas cock could further reduce the operating

pressure when measured at its test point. The pressure drop is relative to the heat input to the boiler (kW), refer to graph below.

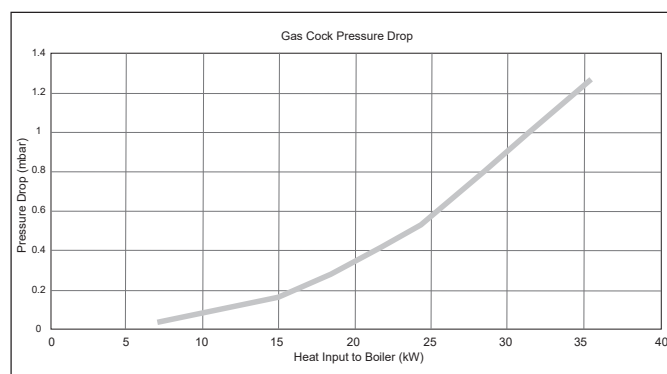

**IMPORTANT** Ensure all gas valve connections are gas tight with a gas soundness check up to the gas control valve. Installation pipes must be fitted in accordance with BS6891. The complete installation **MUST** be tested for gas tightness and purged as described, for the majority of installations the appropriate standard is IGEM/UP/1B [23], but alternatively IGEM/UP/1 [21] or IGEM/UP/1A [22], as appropriate, can be utilized.

### 1.11 WATER CIRCULATION SYSTEM

**IMPORTANT** A minimum length of 1 metre of copper pipe **MUST** be fitted to both flow and return connections from the boiler before connection to any plastic piping.

The central heating system should be in accordance with BS6798 and, in addition, for smallbore and microbore systems, BS EN 12831 and BS EN 14336.

Water treatment is covered later in these instructions.

Refer to Section  
1.22

### 1.12 BOILER CONTROLS

Install controls to ensure that the boiler has no demand when there is no requirement from the system.

Heating systems with TRVs in individual rooms must include a thermostat to control the temperature in rooms without TRVs.

At least 10% of the minimum boiler heat output should be achieved using a room thermostat. A bypass circuit with an automatic bypass valve must be fitted to systems with TRVs or two-port valves on all the radiators to ensure water flow.



### 1.13 ELECTRICAL SUPPLY



**WARNING:** This appliance must be earthed

Wiring external to the appliance **MUST** be in accordance with the current IET (BS7671) Wiring Regulations and any local regulations which apply.

The mains supply to the boiler and system wiring centre shall be through one common fused double pole isolator and for new heating systems, and where practical replacement installations, the isolator shall be situated adjacent to the appliance.

### 1.14 CONDENSATE DRAIN

The condensate drain provided must be connected to the drainage point on site. All condensate drainage pipework and fittings must be made of plastic.



**IMPORTANT:** All pipework should be installed in accordance with BS6798.

The drain outlet on the boiler is sized for standard 21.5 mm overflow pipe. It is a universal fitting to allow use of different brands of pipework.

Refer to Section  
**2.20**

## Section 1 - General

### 1.15 BOILER DIMENSIONS, SERVICES & CLEARANCES

Refer to Section  
2.22

The boiler connections are made on the boiler connection tails.

**The following minimum clearances must be maintained for operation and servicing.**

Additional space will be required for installation, depending upon site conditions.

#### Side and Rear Flue

- Provided that the flue hole is cut accurately, e.g. with a core drill, the flue can be installed from inside the building where wall thicknesses do not exceed 600 mm.

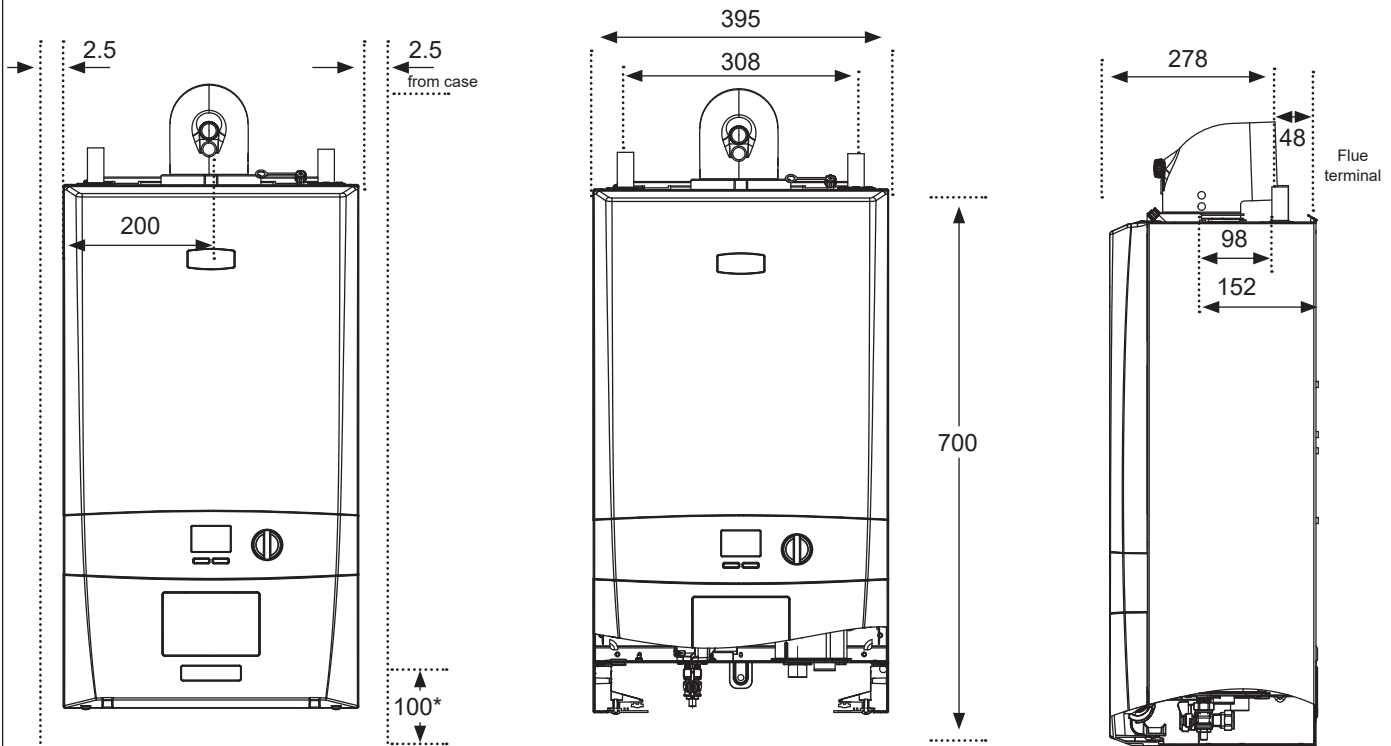

Measurements in mm

Condensate Connection and Gas Connection

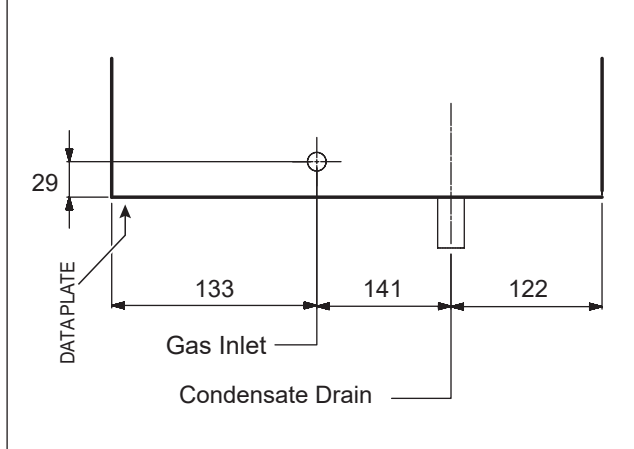

Underside View

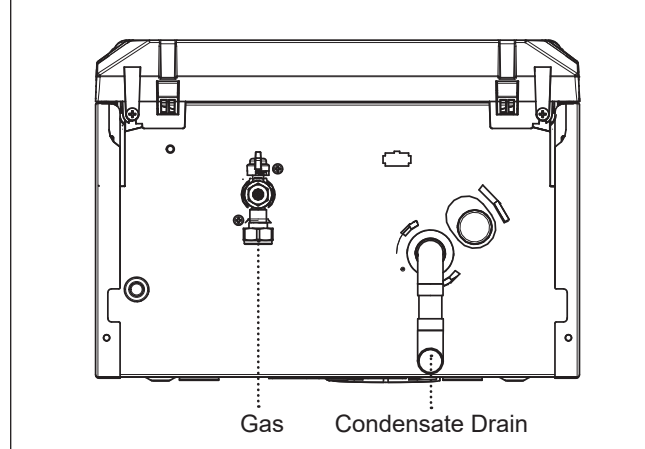

#### Front Clearance

The minimum front clearance when built in to a cupboard is 5 mm from the cupboard door but 450 mm overall clearance is still required, with the cupboard door open, to allow for servicing.

#### \* Bottom Clearance

Bottom clearance after installation can be reduced to 15 mm.

This must be obtained with an easily removable panel to provide the 100 mm clearance required for servicing.

**IMPORTANT** Please ensure there is sufficient clearance either side and below the boiler, particularly from door hinges and the base of a cupboard.



## 1.16 OPEN VENT SYSTEM REQUIREMENTS

Refer to Section 1.19

The system should be vented directly off the boiler flow pipe, as close to the boiler as possible. The cold feed entry should be inverted and **MUST** be positioned between the pump and the vent, and not more than 150 mm away from the vent connection.

**Note.** Combined feed and vent pipes may also be fitted.

There should be a minimum height 450 mm of open vent above the cistern water level. The vertical distance between the highest point of the system and the feed/expansion cistern water level **MUST** not be less than 450 mm. The pump must be fitted on the flow side of the boiler.

A suitable pump is a domestic circulator capable of providing a maximum 20°C temperature differential across the boiler with the whole of the heating circuit open (e.g. Grundfos UPS 15/50, 15/60 or equivalent). With the minimum flow circuit allowed by the controls the differential must not exceed 25 °C.

The vertical distance between the pump and feed/expansion cistern **MUST** comply with the pump manufacturer's minimum requirements, to avoid cavitation. Should these conditions not apply either lower the pump position or raise the cistern above the minimum requirement specified by **Ideal Heating**. The isolation valves should be fitted as close to the pump as possible.

It is recommended that an automatic air vent should be fitted to the return connection.

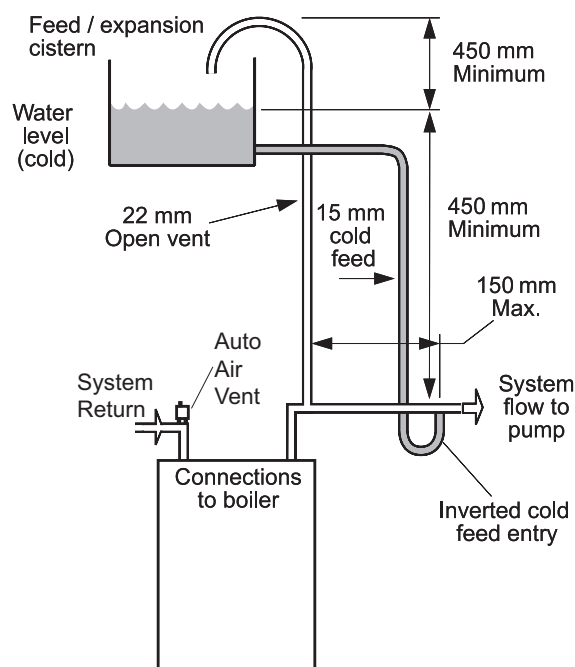

## 1.17 SCHEMATIC PIPEWORK AND SYSTEM BALANCING

Refer to Section 1.15 & 2.11

The boiler does not normally need a bypass but at least some radiators on the heating circuit, of load at least 10% of the minimum boiler output, must be provided with twin lockshield valves so that this minimum heating load is always available.

### Balancing

1. Set the programmer to ON for both CH and HW. Turn the cylinder thermostat down. Close the manual or thermostatic valves on all radiators, leaving the twin lockshield valves (on the radiators referred to above) in the open position. Turn up the room thermostat and adjust these lockshield valves to give boiler flow and return temperatures not more than 20°C apart. These valves should now be left as set.
2. Open all manual or thermostatic radiator valves and adjust the lockshield valves on remaining radiators to give around 20°C temperature drop at each radiator.
3. Turn up the cylinder thermostat and adjust the cylinder balancing valve so that the cylinder achieves a maximum flow consistent with adequate flow to the radiators. Check that with only the domestic hot water loop in circuit a differential temperature of 25°C across the boiler is not exceeded.
4. Adjust room and cylinder thermostats and programmer to NORMAL settings.

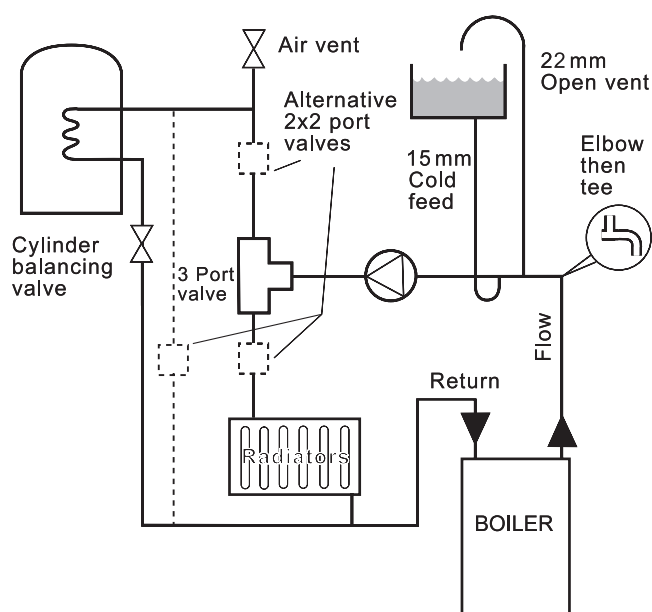

## Section 1 - General

### 1.18 LOW HEAD AND LARGE SYSTEMS WITH EXTENSIVE PIPE RUNS - OPEN VENT

This arrangement is useful for large systems where radiators at the extremities are difficult to vent. This can lead to pumping over with conventional feed and vent arrangements.

The following conditions MUST be observed:

1. The top of the automatic air vent must be below the cold water level.
2. The static water level (cold) must be at least 200mm above the top of the horizontal flow pipe, fitted as shown. The vent connection MUST NOT be made immediately off the top of the boiler as venting is made less efficient.
3. The maximum practical length of 22mm cold feed pipe should be used in order to reduce the effective volume of hot system water expanding into the feed/expansion cistern to a minimum.

**Note.** The pump manufacturers' minimum requirements must be complied with.

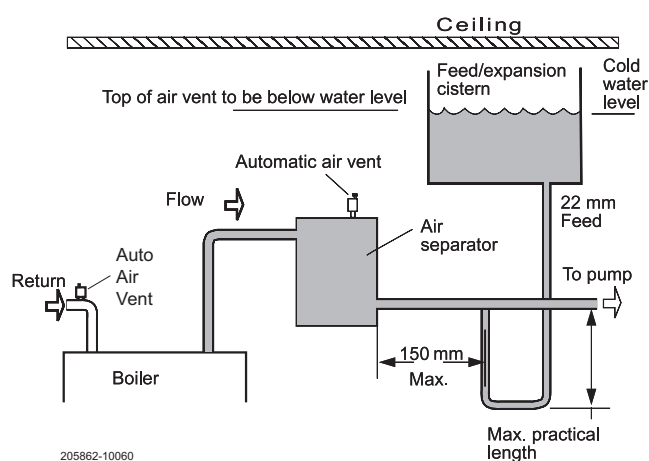

All dimensions in mm

### 1.19 SEALED SYSTEM REQUIREMENTS

#### Notes.

- a. The method of filling, refilling, topping up or flushing sealed primary hot water circuit from the mains via a temporary hose connection is only allowed if acceptable to the local water authority.
- b. When installing the filling device, it must be connected as shown to fully comply with the water regulations.

This may involve the fitting of an additional WRAS approval isolator valve to the mains supply.

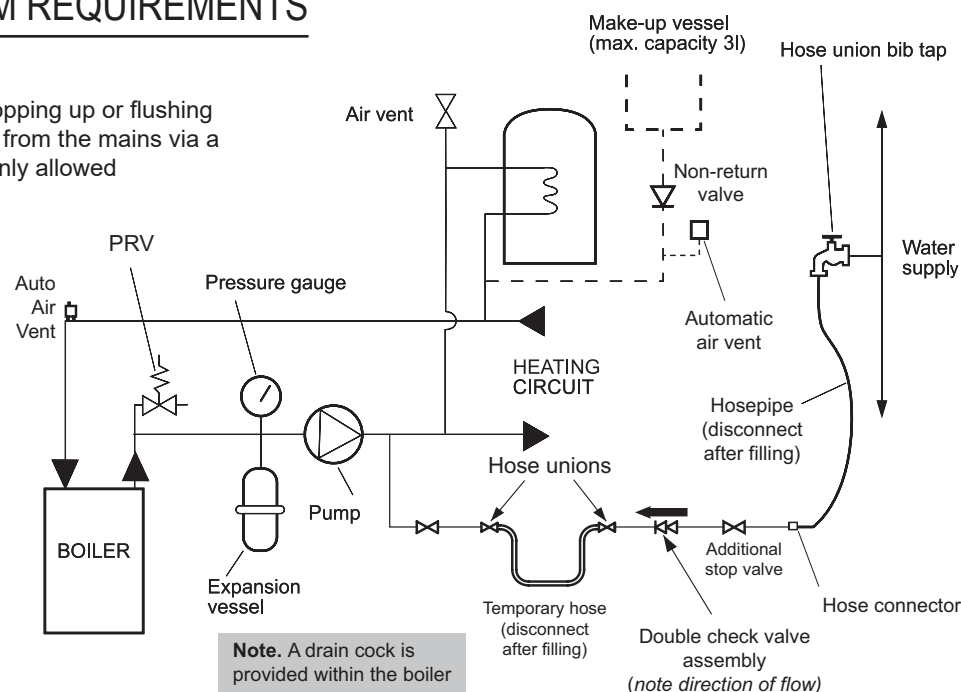

#### 2. PRV

A pressure relief valve (PRV) complying with the relevant requirements of BS.6759 must be fitted in the flow pipe as close to the boiler as possible and with no intervening valve or restriction. The valve should have the following features:

#### 1. General

- a. The installation must comply with the requirements of BS. 6798, BS. EN 12831 and BS. EN 14336.
- b. The installation should be designed to work with flow temperatures of up to 80 °C.
- c. All components of the system, including the heat exchanger of the indirect cylinder, must be suitable for a working pressure of 3 bar and a maximum temperature of 110°C. Care should be taken in making all connections so that the risk of leakage is minimised.

- a. A non-adjustable preset lift pressure not exceeding 3bar.
- b. A manual testing device.
- c. Provision for connection of a discharge pipe. The valve or discharge pipe should be positioned so that the discharge of water or steam cannot create a hazard to the occupants of the premises or cause damage to electrical components and wiring.

## 1.20 SEALED SYSTEM REQUIREMENTS - CONT.

### 3. Pressure Gauge

A pressure gauge covering at least the range 0-4 bar must be fitted to the system. The gauge should be easily seen from the filling point and should preferably be connected at the same point as the expansion vessel.

### 4. Expansion Vessel

- a. A diaphragm type expansion vessel must be connected to a point close to the inlet side of the pump, the connecting pipe being not less than 15 mm size and not incorporating valves of any sort.
- b. The vessel capacity must be adequate to accept the expansion of the system water when heated to 110°C.
- c. The charge pressure must not be less than the static water head above the vessel. The pressure attained in the system when heated to 110° C should be at least 0.35 bar less than the lift pressure of the safety valve.

For guidance on vessel sizing refer to the table in this section.

For further details refer to BS. 5449, BS. 7074:1 and the British Gas Corporation publication 'Material and Installation Specifications for Domestic Central Heating and Hot Water'. For IE refer to the current edition of I.S.813.

### 5. Cylinder

The cylinder must be either of the indirect coil type or a direct cylinder fitted with an immersion calorifier which is suitable for operating on a gauge pressure of 0.35 bar in excess of the PRV setting. Single feed indirect cylinders are not suitable for sealed systems.

### 6. Make-up Water

Provision must be made for replacing water loss from the system, either:

- a. From a manually filled make-up vessel with a readily visible water level. The vessel should be mounted at least 150 mm above the highest point of the system, and be connected through a non-return valve to the system, fitted at least 300 mm below the make-up vessel on the return side of the domestic hot water cylinder or radiators.
- or
- b. Where access to a make-up vessel would be difficult by pre-pressurisation of the system. Refer to 'Filling'.

### 7. Mains Connection

There must be no direct connection to the mains water supply or to the water storage tank supplying domestic water, even through a non-return valve, without the approval of the local water authority.

### 8. Filling

The system may be filled by one of the following methods:

- a. Through a cistern, used for no other purposes, via a ball valve permanently connected directly to a service pipe and/or a cold water distributing pipe. The static head available from the cistern should be adequate to provide the desired initial system design pressure.

The cold feed pipe from the cistern should include a non-return valve and a stop valve with an automatic air vent connected between them, the stop valve being located between the system and the automatic air vent. The stop valve may remain open during normal operation of the system if automatic water make-up is required.

- b. Through a self-contained unit comprising a cistern, pressure booster pump (if required) and, if necessary, an automatic pressure reducing valve and flow restrictor. The cistern should be supplied through a temporary connection from a service pipe or cold water distributing pipe. This unit may remain permanently connected to the heating system to provide limited automatic water make-up. Where the temporary connection is supplied from a service pipe or distributing pipe which also supplies other draw-off points at a lower level then a double check valve shall be installed upstream of the draw-off point.
- c. Through a temporary hose connection from a draw-off tap supplied from a service pipe under mains pressure. Where the mains pressure is excessive a pressure reducing valve shall be used to facilitate filling.

The following fittings shall form a permanent part of the system and shall be fitted in the order stated:

A stop valve complying with the requirements of BS. 1010, Part 2 (the hose from the draw-off tap shall be connected to this fitting).

A test cock.

A double check valve of an approved type.

- Thoroughly flush out the whole of the system with cold water, without the pump in position.
- With the pump fitted, fill and vent the system until the pressure gauge registers 1.5 bar. Examine for leaks.
- Check the operation of the PRV by manually raising the water pressure until the valve lifts. This should occur within  $\pm 0.3$  bar of the preset lift pressure.
- Release water from the system until the initial system design pressure is reached.
- Light the boiler and heat the system to the maximum working temperature. Examine for leaks.
- Turn off the boiler and drain the system while still hot.
- Refill and vent the system.
- Adjust the initial pressure to the required value.

## Section 1 - General

**Sizing procedure for expansion vessels:** The volume of the expansion vessel (litres) fitted to a sealed system shall not be less than that given by the table on the following page, multiplied by a factor of 0.8 (for flow temperatures of less than 83°C).

PRV setting	3.0 bar			2.5 bar			2.0 bar	
Vessel charge and initial system pressure	0.5 bar	1.0 bar	1.5 bar	0.5 bar	1.0 bar	1.5 bar	0.5 bar	1.0 bar
Total water content of system litres	Expansion vessel volume litres							
<b>25</b>	2.1	2.7	3.9	2.3	3.3	5.9	2.8	5.0
<b>50</b>	4.2	5.4	7.8	4.7	6.7	11.8	5.6	10.0
<b>75</b>	6.3	8.2	11.7	7.0	10.0	17.7	8.4	15.0
<b>100</b>	8.3	10.9	15.6	9.4	13.4	23.7	11.3	20.0
<b>125</b>	10.4	13.6	19.5	11.7	16.7	29.6	14.1	25.0
<b>150</b>	12.5	16.3	23.4	14.1	20.1	35.5	16.9	30.0
<b>175</b>	14.6	19.1	27.3	16.4	23.4	41.4	19.7	35.0
<b>200</b>	16.7	21.8	31.2	18.8	26.8	47.4	22.6	40.0
<b>225</b>	18.7	24.5	35.1	21.1	30.1	53.3	25.4	45.0
<b>250</b>	20.8	27.2	39.0	23.5	33.5	59.2	28.2	50.0
<b>275</b>	22.9	30.0	42.9	25.8	36.8	65.1	31.0	55.0
<b>300</b>	25.0	32.7	46.8	28.2	40.2	71.1	33.9	60.0
<b>Multiplying factors for other system volumes</b>	0.0833	0.109	0.156	0.094	0.134	0.237	0.113	0.20

### 1.21 SYSTEM BALANCING

**Note.** Systems incorporating zone valves which could completely cut off the flow through the system must also include a bypass.

The boiler does not normally need a bypass but at least some radiators on the heating circuit, of load of at least 10% of the minimum boiler output, must be provided with twin lockshield valves so that this minimum heating load is always available.

#### Balancing

1. Set the programmer to ON.

Close the manual or thermostatic valves on all radiators, leaving the twin lockshield valves (on the radiators referred to above) in the OPEN position.

Turn up the room thermostat and adjust the lockshield valve to give an uninterrupted flow through the radiator.

These valves should now be left as set.

2. Open all manual or thermostatic radiator valves and adjust the lockshield valves on the remaining radiators, to give around 20°C temperature drop at each radiator.
3. Adjust the room thermostat and programmer to NORMAL settings.
3. Adjust the room thermostat and programmer to NORMAL settings.

### 1.22 WATER TREATMENT

#### Central Heating

The Logic range of boilers have an ALUMINIUM alloy heat exchanger.

**! IMPORTANT** The application of any other treatment to this product may render the guarantee of Ideal Heating invalid.

**Ideal Heating** recommend Water Treatment in accordance with the Benchmark Guidance Notes on Water Treatment in Central Heating Systems.

If water treatment is used **Ideal Heating** recommend only the use of SCALEMASTER SM-1 PRO, FERNOX, MBI, ADEY MC1, SENTINEL X100 or CALMAG CM100 inhibitors and associated water treatment products, which must be used in accordance with the manufacturers' instructions.

This boiler can be used with a water softener. However, the heating system should not be filled with softened water as any softening chemicals could enhance corrosion of certain materials in the heating system, including aluminium and steel. The heating system should always be filled from the bypass on the water softener installation.

#### Notes

1. It is most important that the correct concentration of the water treatment products is maintained in accordance with the manufacturers' instructions.
2. If the boiler is installed in an existing system any unsuitable additives MUST be removed by thorough cleansing. BS7593:2019 details the steps necessary to clean a domestic heating system.
3. In hard water areas, treatment to prevent lime scale may be necessary - however the use of artificially softened water is NOT permitted.
4. Under no circumstances should the boiler be fired before the system has been thoroughly flushed.

For further information contact:

**Fernox** [www.fernox.com](http://www.fernox.com) Tel: +44 (0) 3301 007750

**Sentinel Performance Solutions**  
[www.sentinelprotects.com](http://www.sentinelprotects.com) Tel: +44 (0) 1928 704330

**Scalemaster Water Treatment Products**  
[www.scalemaster.co.uk](http://www.scalemaster.co.uk) Tel: +44 (0) 1785 811636

**Calmag Ltd.** [www.calmag Ltd.com](http://www.calmag Ltd.com)  
Tel: +44 (0) 1535 210320

**Adey** [www.adey.com](http://www.adey.com) Tel: +44 (0) 1242 546700

## Section 2 - Installation

### 2.1 BOILER ASSEMBLY - EXPLODED VIEW

- 106 PIPE - RETURN
- 107 FLOW MANIFOLD/ASSEMBLY
- 203 GAS COCK
- 205 GAS VALVE
- 206 PIPE - GAS INJECTOR
- 211 INJECTOR ASSEMBLY
- 214 VENTURI
- 215 FAN
- 217 BURNER
- 218 GASKET - BURNER
- 219 SUMP CLEAN OUT COVER
- 223 FLUE MANIFOLD
- 224 FLUE MANIFOLD TOP
- 225 FLUE MANIFOLD - TOP SEALING CAP

- 226 FLUE MANIFOLD - REAR SEALING CAP
- 227 CLAMP RETAINING FLUE TURRET
- 228 HOSE CONDENSATE INTERNAL
- 229 SIPHON TRAP
- 231 CONDENSATE OUTLET CONNECTION
- 233 FLUE SENSING NIPPLE
- 301 CONTROLS BOX HINGES & HARNESS CLIPS
- 302 PCB
- 304 CONTROL THERMISTOR (FLOW / RETURN)
- 305 POTENTIOMETER & BLANK KNOBS
- 306 ELECTRODE IGNITION
- 308 IGNITOR UNIT

- 309 FLOW THERMISTOR
- 313 IGNITION DETECTION LEAD
- 324 CONTROLS BOX LID
- 325 CONTROL BOX FRONT
- 401 HEAT ENGINE
- 404 ELBOW RETURN CONNECTOR
- 503 WALL MOUNTING & FLOW SUPPORT BRACKET
- 504 FRONT PANEL
- 505 FASCIA
- 506 BRACKET - GAS VALVE

Note that item numbers are linked to the spares list

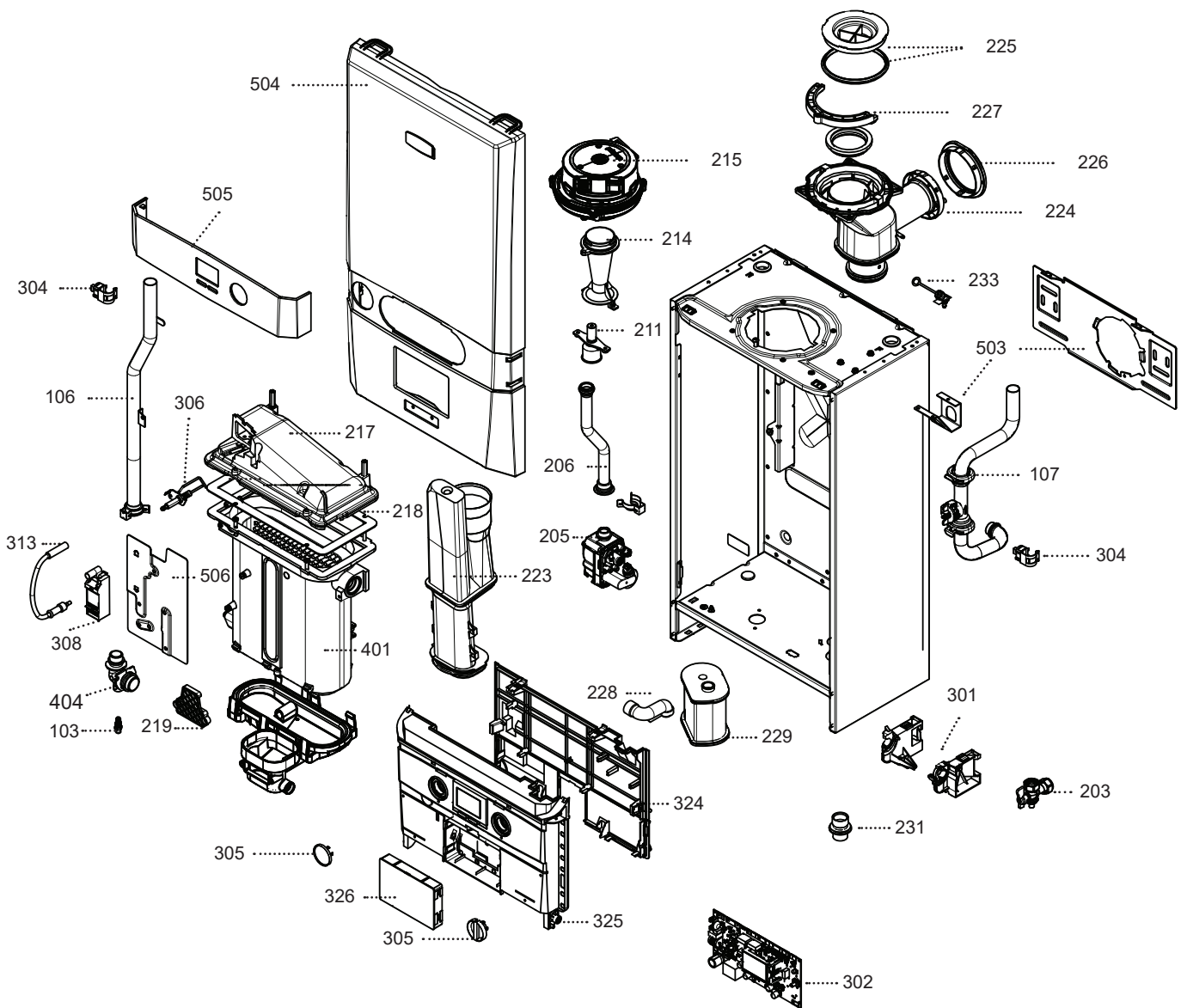



## Section 2 - Installation

### 2.2 UNPACKING

The boiler is supplied fully assembled in Pack A. A telescopic or non-telescopic flue assembly for rear or side flue outlet in Pack B is supplied as a separate order.

#### Pack A Contents

1. Boiler
2. Hardware Pack Box
3. Wall Mounting Plate
4. These Installation/Users Instructions
5. Wall Mounting Template
6. Boiler Warranty

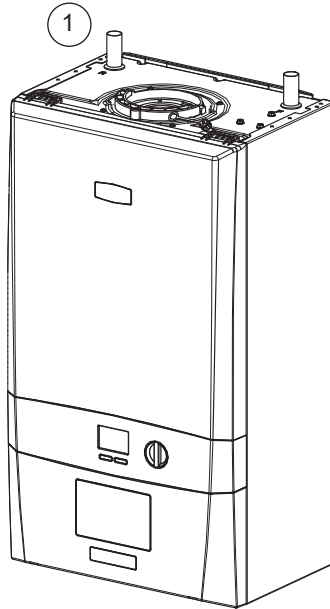

#### Unpack and check the contents

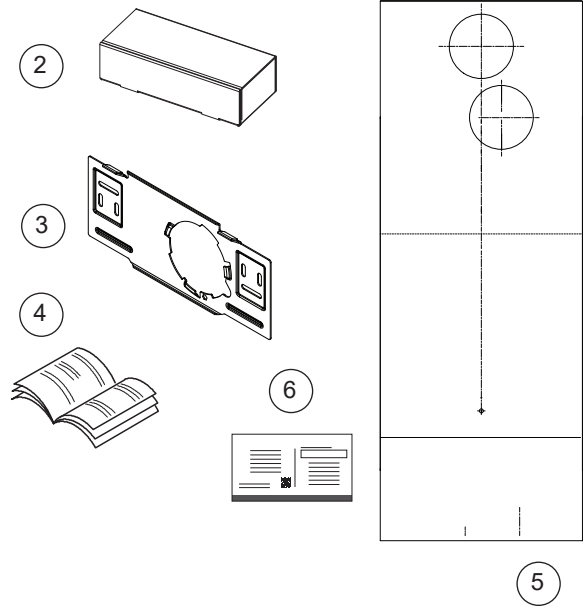

#### Hardware Pack

##### Box Contents

7. 1x HP Box - 180 x 111 x 57.5 mm
8. 1x Gas Cock

##### Accessory Bag Contents

9. 1x Washers\*
10. 2x Wall Plugs
11. 2x Screws

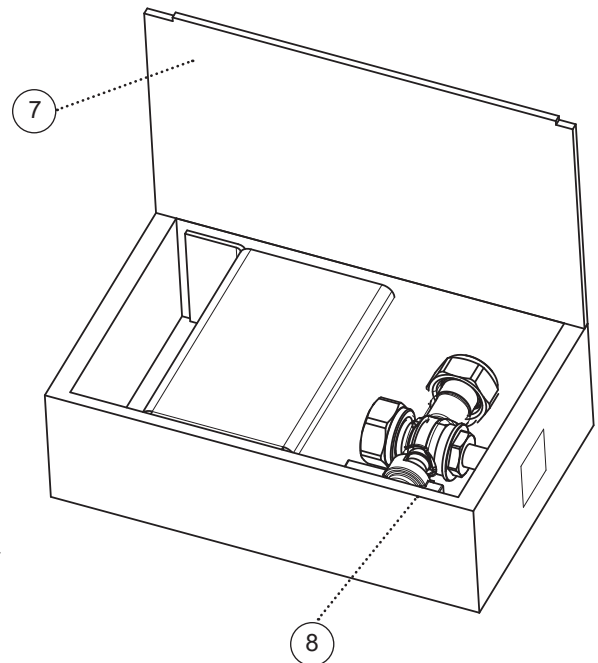
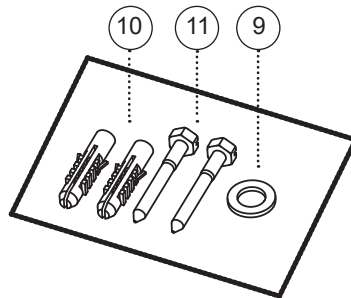
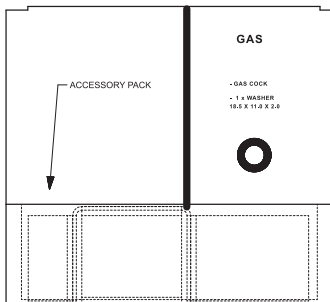

\*Refer to valve/washer template inside hardware pack box lid.

## 2.3 WALL MOUNTING TEMPLATE

The wall mounting template is located on the internal protective packaging. The template shows the position of the fixing and rear flue centre holes for a standard installation

Care **MUST** be taken to ensure the correct holes are drilled.

1. Secure the template into the required position. Ensure it is square by hanging a plumbline.
2. If fitting a side flue, extend the flue centreline onto the side by 155 mm on a standard wall fix or 200 mm if using a stand-off bracket.
3. Mark the following on to the wall:
  - a The selected group of wall mounting screw holes.
  - b. The centre position of the flue duct. Marking both the centre and the circumference of the flue duct.
4. Remove the template plate from the wall.

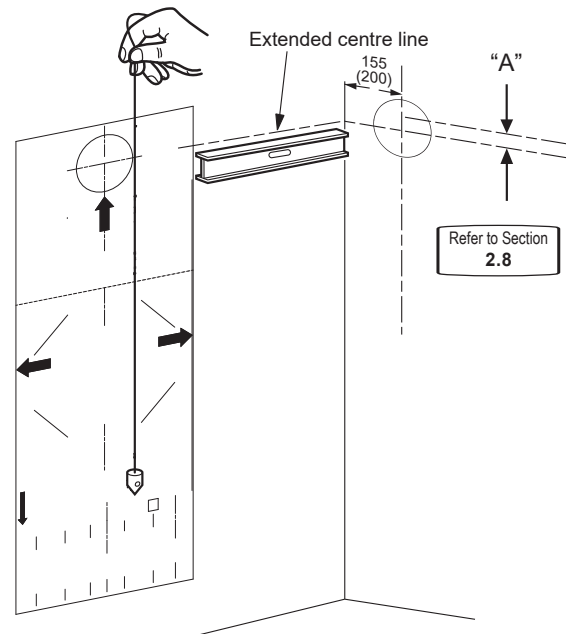

## 2.4 PREPARING THE WALL

**WARNING:** Ensure that, during the cutting operation, masonry falling outside of the building does not cause damage or personal injury.

1. Check all of the hole positions before drilling.
2. Cut the flue hole with a 127 mm core boring tool, ensure the hole is square to the wall.
3. Drill the 2 mounting holes with a 7.5 mm / 8 mm masonry drill and insert the plastic plugs provided.
4. Locate 2 No.14 x 50 mm screws in the wall mounting plate (one at each side, in any of the 3 holes provided at each side) and screw home. Ensure mounting bracket is level.

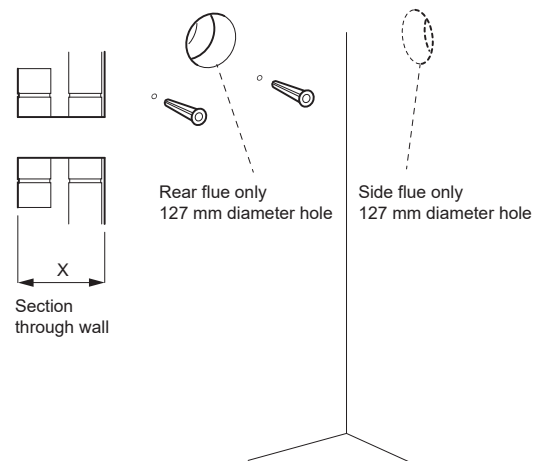

## 2.5 FITTING THE WALL MOUNTING PLATE

Screw the wall mounting plate to the wall using 2 wall plugs fitted previously with the 2 screws provided.

Choose one of the 2 sets of slots in left and right bank. Ensure that at least one of the screws is fitted into a top slot and the mounting bracket is level.

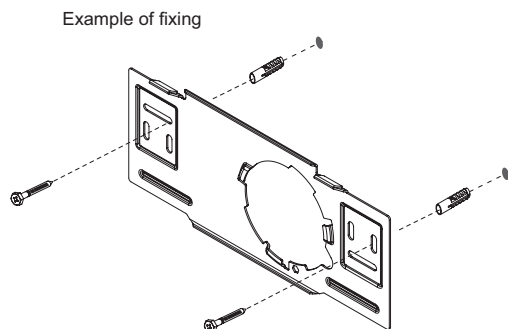



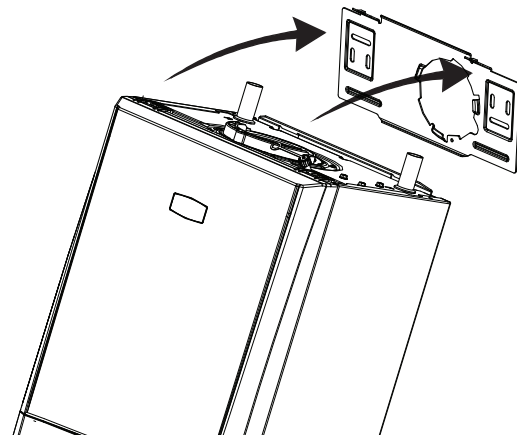

## 2.6 MOUNTING THE BOILER

1. Lift the boiler onto the wall mounting plate and locate it over the 2 tabs.

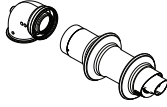
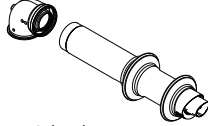
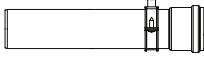
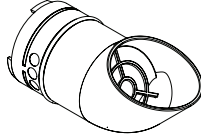
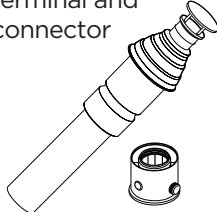

## 2.7 FLUES AND LOCATIONS

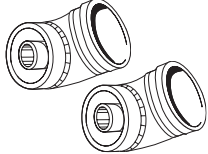
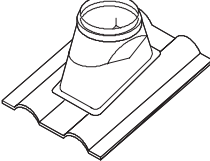
This installation & servicing manual must be read in conjunction with flue kit and fitting guide.

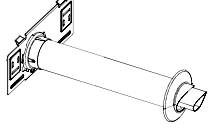
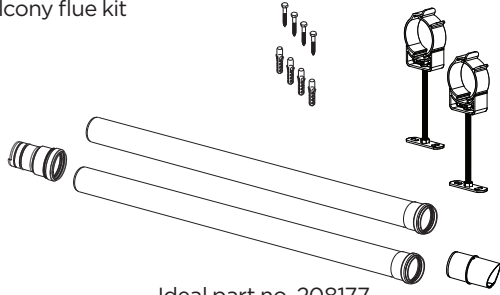
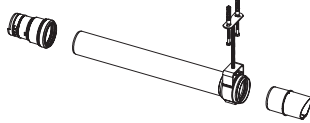
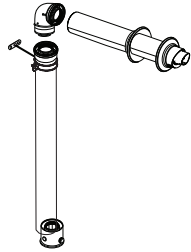
<p>Telescopic horizontal flue 0.5 or 0.7 m</p>  <p>Ideal part no. 0.5 m 208169 0.7 m 208174</p>	<p>Horizontal flue 0.6 or 0.8 m</p>  <p>Ideal part no. 0.6 m 208171 0.8 m 217442</p>	<p>Flue extension 0.5 m, 1 m or 2 m</p>  <p>Ideal part no. 0.5 m 211037 1 m 203129 2 m 211038</p>	<p>Flue deflector</p>  <p>Ideal part no. 208176</p>	<p>Vertical flue terminal and connector</p>  <p>Ideal part no. 211039</p>
<p>Flue elbow 90°</p>  <p>Ideal part no. 203130</p>	<p>Flue elbow 45°</p>  <p>Ideal part no. 203131</p>	<p>Weather collar pitched roof</p>  <p>Ideal part no. 152258</p>	<p>Weather collar flat roof</p>  <p>Ideal part no. 152259</p>	<p>Rear outlet flue (55/80)</p>  <p>Ideal part no. 205990</p>
<p>Balcony flue kit</p>  <p>Ideal part no. 208177</p>		<p>Soffit kit</p>  <p>Ideal part no. 211302</p>	<p>Raised horizontal flue kit</p>  <p>Ideal part no. 208290</p>	

### ⚠ WARNING:

- It is critical that products of combustion cannot re-enter the building.
- The flue terminal must always have a free passage of air.

### ⚠ CAUTION:

- White sections of the flue must not be visible outside.
- Install a flue terminal guard where the flue terminal is less than 2 metres above a platform where persons can walk or come into contact with the terminal.
- Water is the only permitted lubricant for flue assembly.

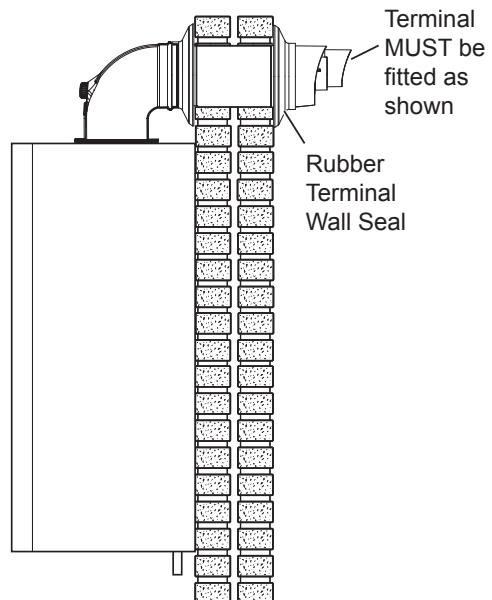



2.8 FLUES AND LOCATIONS - CONT

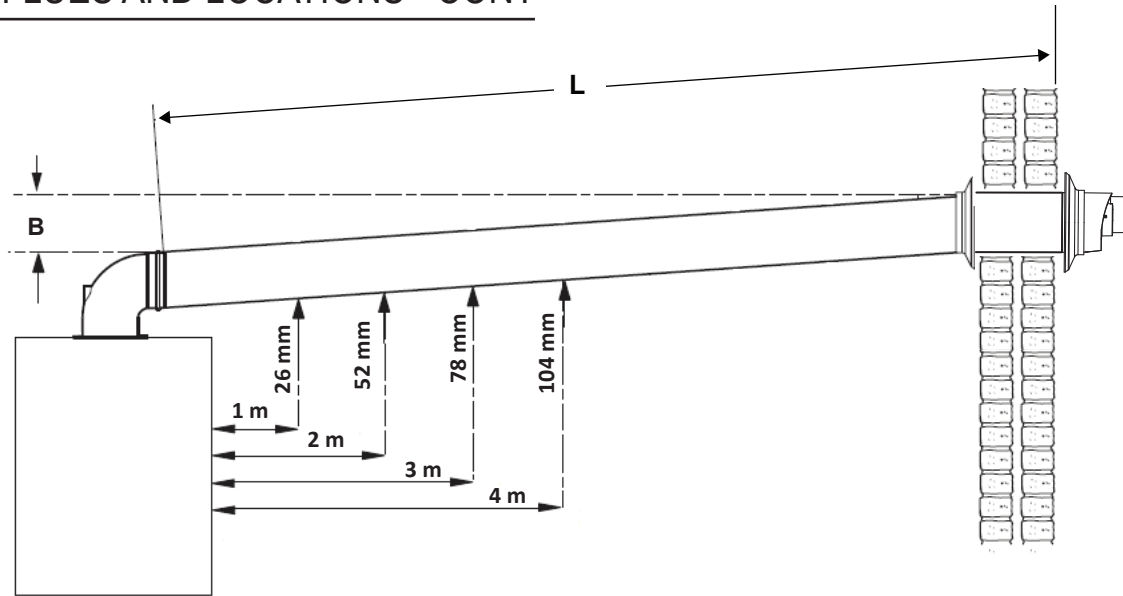

**B = Top Clearance**

Top Clearance is measure from the top of the turret to the top of the hole where the flue terminates.

**L = Effective flue length.**

The effective length of the flue is measured from the edge of the turret to the flue terminal lip.

Flue systems that require extension kits must be installed with a 1.5° decline from the flue terminal back to the boiler. A 1.5° decline can be achieved by designing the flue with a 26 mm rise per meter length of flue.

**IMPORTANT INFORMATION**

Install the flue in accordance to BS 5440:1 2008  
Position the terminal, so the products of combustion do not cause a nuisance.

The terminal outlet duct must not be closer than 25 mm to combustible material.

The flue is secured in the wall using either sand and cement or heatproof silicone.

The flue must be supported by a bracket every metre of flue length and at every change of direction. Concealed flues must have inspection hatches no more than 1.5 metres from joints.

Where possible inspection hatches should be located at change of directions. Where this is not possible then bends must be viewable from both sides.

Inspection hatches must be at least 300 mm<sup>2</sup>.

Horizontal	Maximum Effective Flue Length
12-24 kW	9.0 metres
30 kW	8.0 metres
Vertical	
12-24/30 kW	7.5 metres
Elbows increase resistance and have an effective flue length equivalence. The following table is an example.	
Part	Resistance
45° elbow	0.6 metres
90° elbow	1.0 metres

Table 3 - Flue Terminal Position

Flue Terminal Positions	Min. Spacing*
1. Directly below, above or alongside an opening.	300 mm
2. Below guttering, drain pipes or soil pipes.	75 mm 25 mm*
3. Below eaves.	200 mm 25 mm*
4. Below balconies or a car port roof.	200 mm 25 mm*
5. From vertical drain pipes or soil pipes.	150 mm 25 mm*
6. From an internal or external corner or a boundary alongside the terminal.	300 mm 25 mm*
7. Above adjacent ground, roof or balcony level.	300 mm
8. From a surface or a boundary facing the terminal.	600 mm
9. From a terminal facing a terminal.	1200 mm
10. From an opening in a car port into dwelling.	1200 mm
11. Vertically from a terminal on the same wall.	1500 mm
12. Horizontally from a terminal wall.	300 mm
13. Horizontally from an adjacent window	600 mm
14. Facing an opening into an adjacent building	2000 mm
15. At an angle to the boundary	90° 300 mm 45° 600 mm
16. Parallel to a boundary	300 mm
17. Below ground level – open light well	
	a) Below ground <1,000 mm
	b) Above floor level 300 mm
	c) From side 300 mm
	d) From facing surface 600 mm

\*Only one reduction down to 25mm is allowed per installation.

FLUE OUTLET

## Section 2 - Installation

### 2.9 HORIZONTAL FLUE POSITIONS

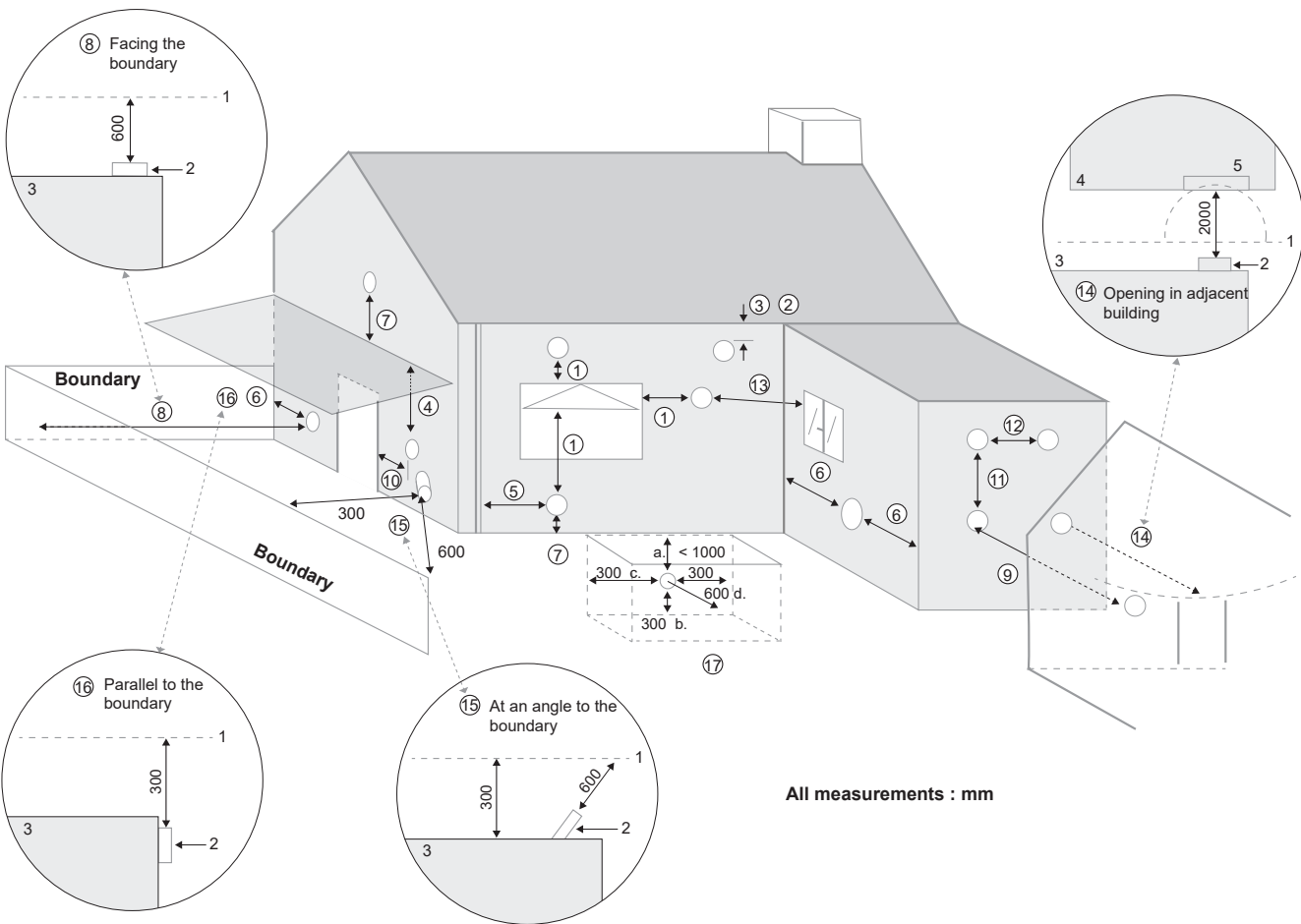

Refer to Table 3

### 2.10 VERTICAL FLUE POSITIONS

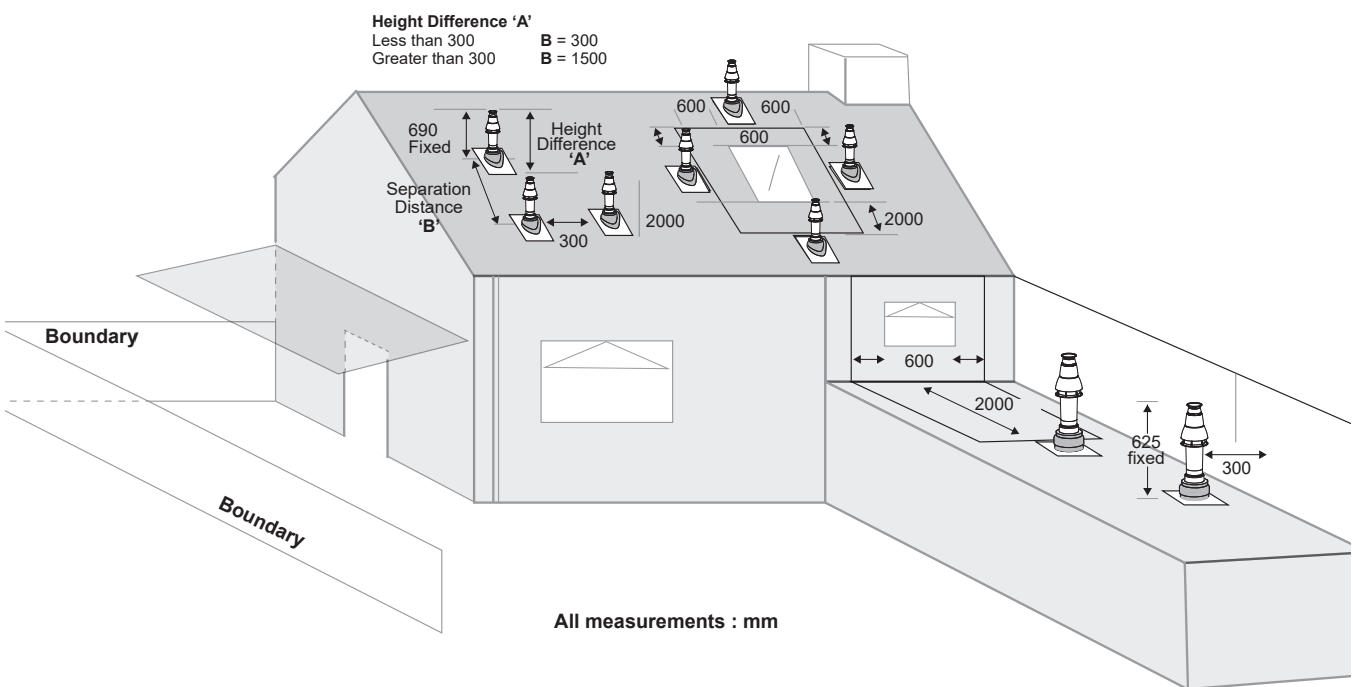

Refer to Table 3

## Section 2 - Installation

### 2.11 FLUE SYSTEM DIMENSIONS

#### Flue Design

#### ⚠ IMPORTANT:

1. Flue lengths may vary, always measure flue lengths before cutting.
2. Effective flue length and actual flue length are different measurements.
3. Effective flue length is made up of the flue length equivalence and the flue sections between the turret, elbows and terminal.
4. Actual flue length is the amount of flue needed to achieve the effective flue length, this includes insertions.
5. It is recommended that a support bracket is fitted on every 1 metre of pipe work used and the bracket is located as close to the collar as possible. The bracketing must ensure a 1.5 degree fall back to the appliance.

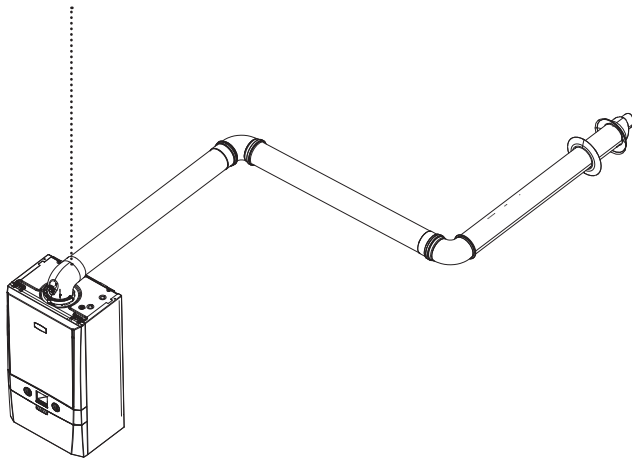
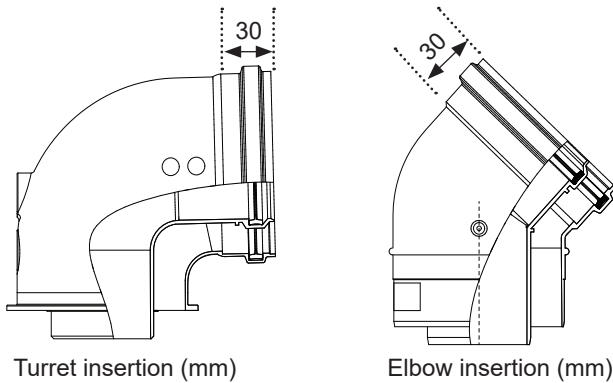

Part	Actual Length	Insertion	Effective Length
1 m flue length	1000 mm	30 mm	970 mm
90° elbow		n/a	1000 mm
1 m flue length	1000 mm	30 mm	970 mm
90° elbow		n/a	1000 mm
0.6 m flue terminal	600 mm	30 mm	570 mm
Total			4.510 mm

### 2.12 FITTING THE TURRET

1. Ensure the condensate trap is filled with water
2. Ensure the rubber seal is not damaged and fitted correctly on the appliance manifold.
3. Firmly hold the flue and push the turret on until it has travelled 30 mm ensuring the flue has not rotated or moved forward.
4. Push the turret into the manifold ensuring the upper plastic lip is flush with the top of the manifold.
5. Fully engage the clamp location section into the manifold location hole and rotate down onto the flange.
6. Use the securing screws to secure the clamp to the appliance.
7. Ensure all sample points are accessible and all sample plugs and caps are fitted.

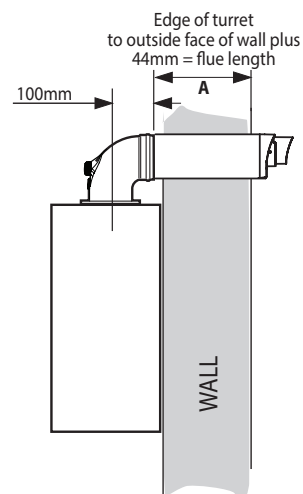
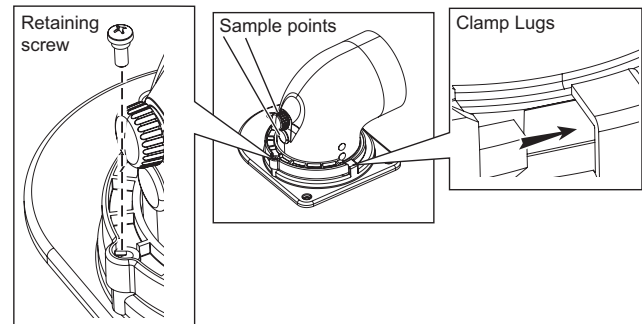
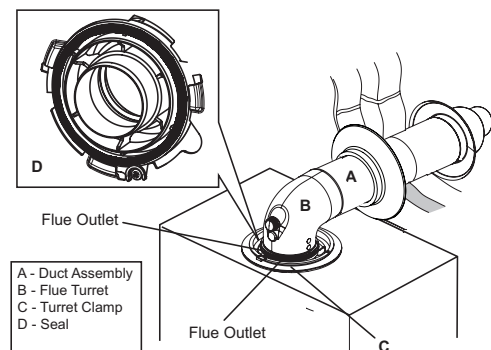

FLUE OUTLET

## 2.13 CUTTING THE FLUE

### CUTTING HORIZONTAL FLUE TERMINAL (non-telescopic)

1. Measure the required cut flue length ( $A + 44$  mm)
2. Measure from the outer terminal lip to the end of outer tube. Mark the required cut length ( $A + 44$  mm) around the circumference of the outer tube and cut following the mark to ensure it is cut square.
3. Mark and cut the inner tube 10 mm longer than the outer tube ensure the cut is square.
4. Remove all burrs on the inner and outer tube and place a light chamfer on the inner tube to aid with assembly.

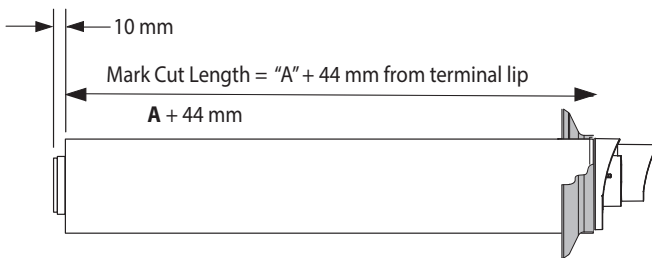

### SETTING TELESCOPIC FLUE

1. Measure the required length ( $A + 44$  mm)
2. Pull flue apart until the desired length is achieved ensuring the stop mark is not visible.
3. Ensure both flue seams are at the top and the flue outlet terminal is uppermost.
4. Drill a 3.5 mm hole through the small and large outer tube using the pilot hole on the large outer tube.
5. Secure large and small outer tube using the screws provided.
6. Seal the joint on the out tube with the tape provided.
7. Fit the internal and external wall seals.

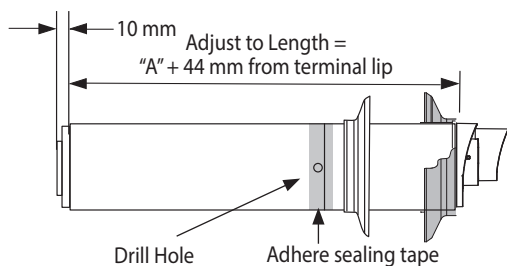

### FITTING THE FLUE THROUGH THE WALL (Internal Installation)

1. Measure the thickness of the wall.
2. To this measurement add 14 mm.
3. Make a mark on the flue shown as mark 1 (top right).
4. Make another mark on the flue a further 14 mm in shown as Mark 2 above right.
5. Fit the external wall seal (black) to the flue terminal ensuring it is fitted on the terminal outer lip seal.
6. Fit the inner wall seal approximately 65 mm prior to Mark 2.

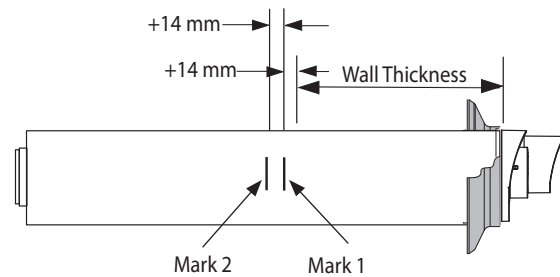

7. Place the terminal end of the flue into the 127 mm core drilled centrally and slowly apply slight pressure and move the flue up or down or side to side. This will cause the external wall seal to fold in and allow the flue to pass through the wall.
8. When the inner wall seal is flush against the wall pull back the flue until Mark 1 is flush with the inner wall surface.
9. Hold the flue steady and push the inner wall seal towards the wall until Mark 2 is just visible.

### FITTING THE FLUE THROUGH THE WALL (External Installation)

1. Follow steps 1 - 5 from above.
2. Push the flue through the 127 mm core drilled hole from the outside
3. Return inside the property and fit the inner wall seal to the flue.
4. Pull the flue internally until Mark 1 is flush with the inner wall surface.
5. Holding the flue in this position push the inner wall seal towards the wall until Mark 2 is just visible.

If Mark 1 is not flush with the inner wall surface and can be seen prior to the wall surface, then the external wall seal will have been dislodged and will require to be re-fitted. If this situation occurs, then please start the process from the beginning.

On completion the flue will be correctly installed as below.

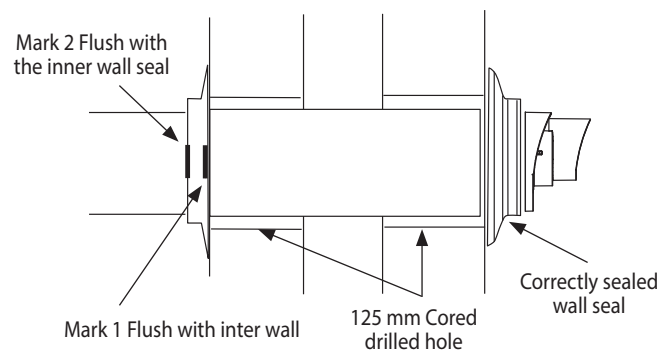

If the flue terminal has any of the white internal flue section visible, the flue has not been correctly installed and requires adjustment. The external wall seal not be correctly positioned on the terminal lip.

## Section 2 - Installation

A video showing how to correctly measure and fit a flue can be found by viewing the QR Code.

**SCAN**  
for Flue Fitting  
Video's



For the full range of  
**FLUE AND ACCESSORIES**  
please visit [idealheating.com/flues](http://idealheating.com/flues)

**SCAN**  
for Flues and  
Accessories Guide



### 2.14 ASSEMBLING THE VERTICAL FLUE

Determine the correct height that the flue should terminate above the roof. If after calculating or measuring the overall flue height from the top of the boiler, it is necessary to cut both pipes of assembly A, then ensure they are cut equally leaving the inner flue tube longer than the outer air tube as supplied.

Ensure the cut pipe ends are free from any burrs.

1. Position the roof flashing plate (supplied separately) over the hole cut in the roof and insert flue terminal from the roof end.
2. Fit the vertical connector (supplied in kit) in accordance with the instructions provided.
3. Secure the vertical connector by applying downward pressure on the connector.
4. Position the clamp on the top face of the flue manifold and push it horizontally backwards. Locate both clamp lugs into the flue manifold and secure to the flue manifold with the M5 retaining screw.

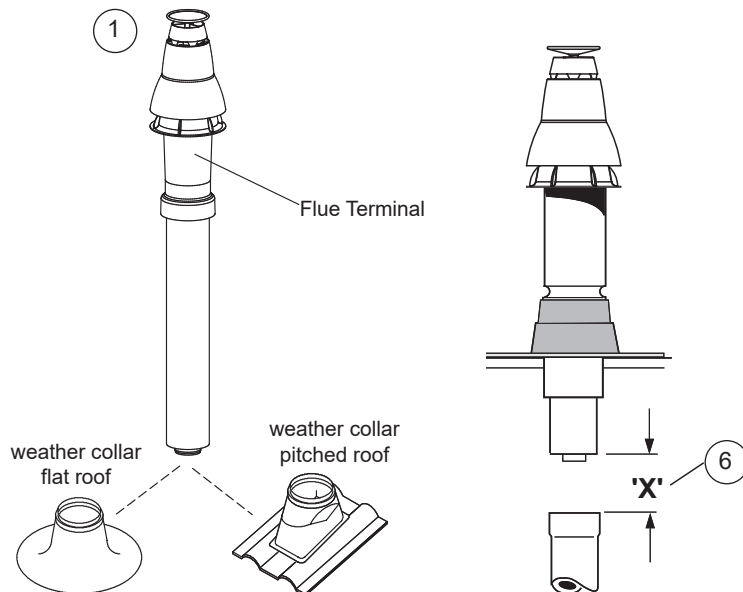
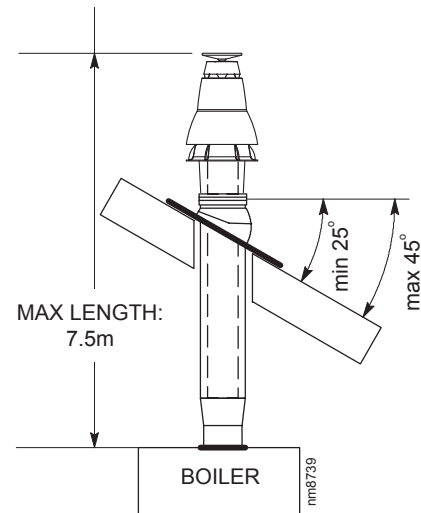

5. Push extension duct (if required (supplied separately)) into vertical connector.

**Note.** Ensure turret sample points are servicable and all caps and plugs are fitted. Fill the condense trap/siphon with water.

6. If the last extension duct requires cutting, measure 'X', the distance (outer ducts), between the duct and the terminal and add 100 mm to this dimension. This gives the length of the last extension duct.

**Note.** Check the position of the inner flue duct relative to the outer duct on the assembled extension duct(s) and ensure the terminal flue duct is cut longer than the air duct to ensure engagement in the final flue duct seal.

7. Finally ensure the roof flashing plate is correctly sealed to the roof.

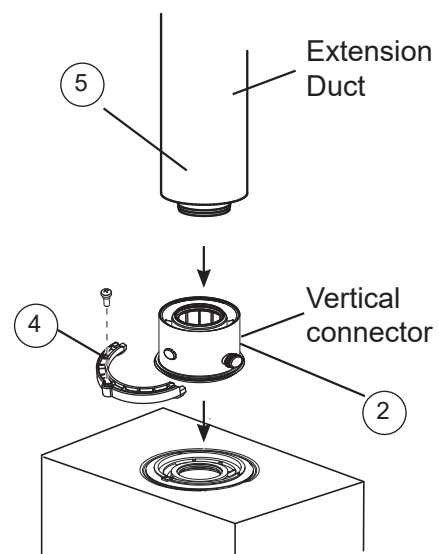

FLUE OUTLET

## 2.15 REAR FLUE OUTLET KIT (55/80) ASSEMBLY - EXPLODED VIEW

1. Rear flue (55/80)
2. Plastic Connector
3. Wall Mounting Plate

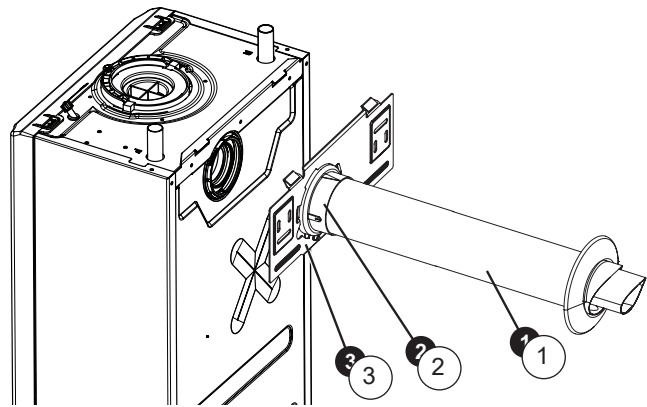

## 2.16 TERMINAL WALL SEAL ASSEMBLY / POSITIONING

Prior to fitting the flue, the rubber terminal wall seal provided in the flue pack MUST be fitted to the flue terminal as shown below.

Once the flue is installed it is **IMPORTANT** that the rubber terminal wall seal is pressed against the outside wall to create an adequate seal between the flue and wall as shown below.

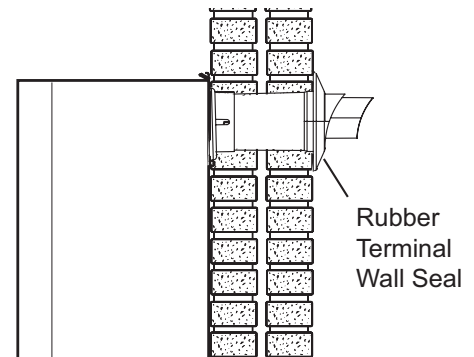
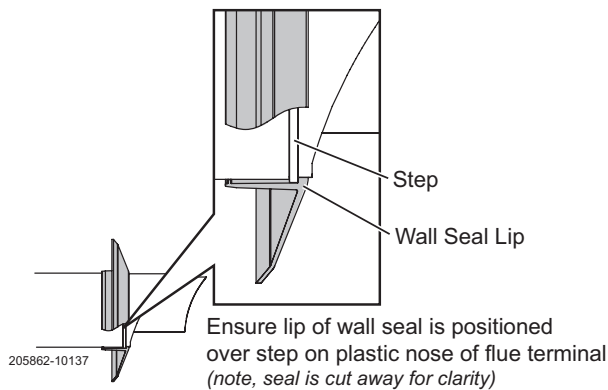

## 2.17 SETTING THE REAR FLUE LENGTH - WALL THICKNESS OF 115 MM TO 442 MM

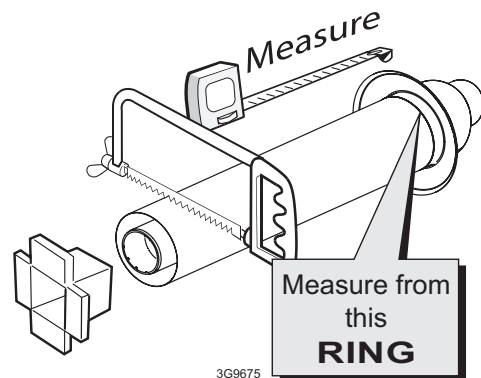
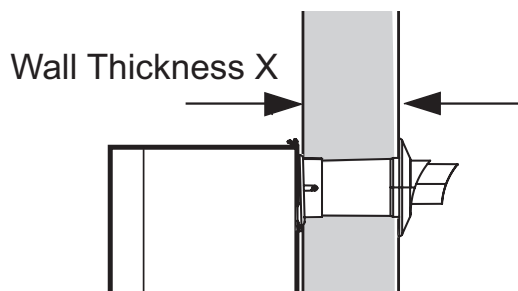

1. Measure and note wall thickness X.

Refer to Section 2.14

2. Add 8 mm to dimension X and, measuring from the ring, cut the outer tube only.
3. To ensure the tube is cut square, mark the flue all the way around.
4. Cut the inner tube to a length 10 mm longer to aid engagement, using the cutting aid provided.

**Note.** If the stand-off frame is used, it is essential to add 45 mm to 'X' the measured wall thickness when marking the flue (this will allow for the fitted frame)



## Section 2 - Installation

### 2.18 FITTING THE WALL PLATE / REAR FLUE TERMINAL ASSEMBLY

1. Ensure the rubber terminal wall seal is fitted to the terminal.  

Refer to Section 2.16
2. Insert the previously cut to length terminal assembly into the plastic connector.
3. Line up the mark on the top of the plastic connector with the top of the terminal (marked with a label).
4. Drill 2 - 3.5mm dia holes through each side of the plastic connector and the air duct and fit the two self tapping screws (provided) to retain the duct terminal assembly to the plastic connector.
5. Seal the joint between the plastic connector and the terminal air duct with the tape provided.
6. Push the terminal assembly through the prepared hole in the wall until the rubber seal clears the outside wall. Rest the assembly in the hole while fitting the wall mounting plate.
7. Screw the wall mounting plate to the wall using 2 wall plugs (previously fitted) with the 2 screws provided. Choose one of the 2 sets of slots in the left and right bank. Ensure that at least one of the screws is fitted into a top slot.
8. Pull the flue assembly back through the wall mounting plate to seal against the outside wall face and ensure the 3 locating tabs are pulled through the wall mounting plate slots.
9. Turn the plastic connector clockwise to lock the connector into the wall plate.
10. Retain with the M5 screws provided.

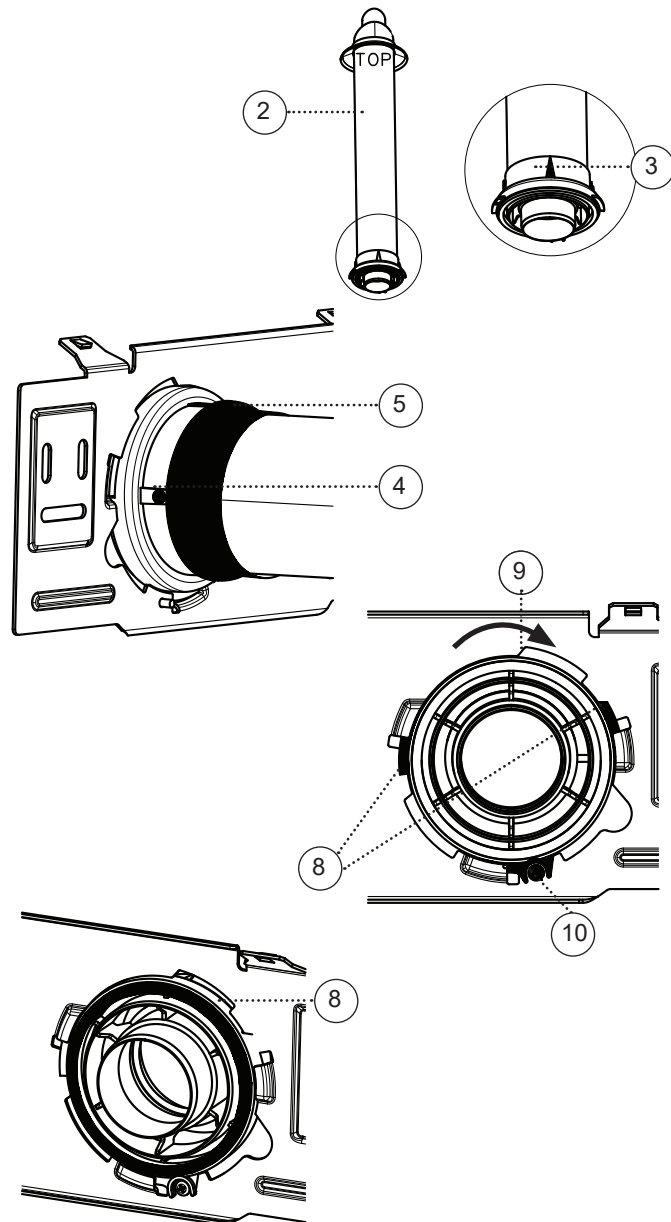

### 2.19 MOUNTING THE BOILER - REAR FLUE OUTLET KIT (55/80)

1. Remove the rear flue blanking disk.
2. Lift the boiler onto the wall plate, (refer to the introduction section for safe handling advice), ensuring the boiler is offered to the bracket tabs at an angle as shown below, and carefully allow the boiler to swing down to the wall as this movement engages the rear flue air and flue seal.
3. Screw the boiler bottom retaining bracket to the wall with the screw provided.
4. Remove the top flue blanking disk. Fill the condensate trap within the boiler by pouring a cupful of water into the flue outlet. Take care to ensure that the water is only poured into the flue outlet, and does not spill into the boiler casing.
5. Replace the top flue blanking disc and retain with the horseshoe bracket and fixing screw previously removed.  
 During assembly check that the flue seals do not become dislodged.

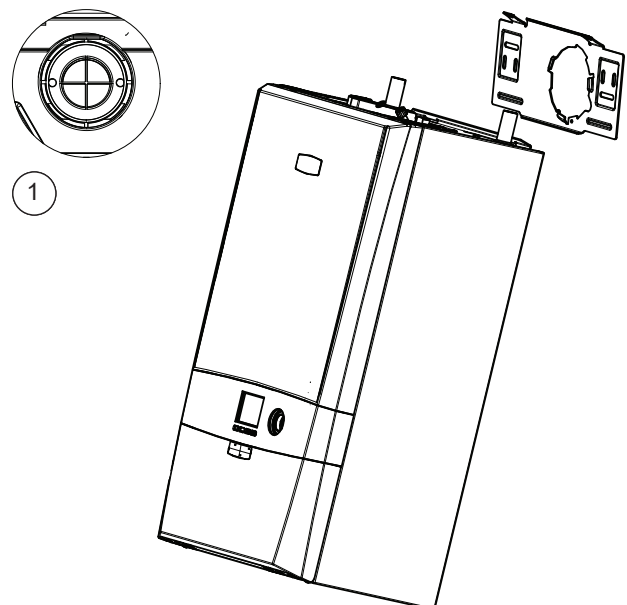

FLUE OUTLET

## 2.20 CONDENSATE DRAIN

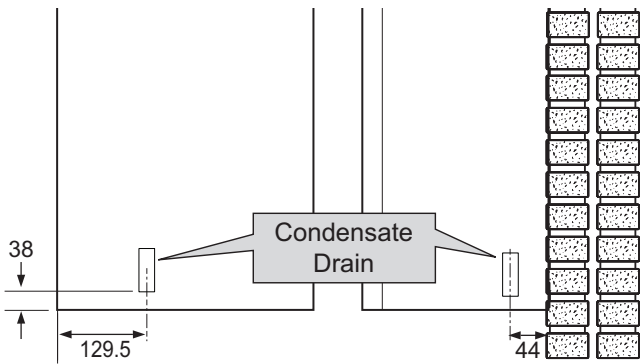

This appliance is fitted with a siphonic 75mm condensate trap system that requires filling before operating the appliance for the 1st time or after maintenance.

All condensate pipework should conform to the following:

- Where a new or replacement boiler is being installed, access to an internal 'gravity discharge' termination should be one of the main factors considered in determining boiler location.
- Plastic with push fit or solvent connections.
- Internal plastic pipe work a minimum of 19mm ID (typically 22mm OD).
- External plastic pipe must be a minimum of 30mm ID (typically 32 OD) before it passes through the sleeved wall.
- All horizontal pipe runs must fall a minimum of 52mm per metre away from the Boiler.
- External & unheated pipework should be kept to a minimum and insulated with Class "O" waterproof pipe insulation (UV Resistant).
- All installations must be carried out in accordance to the relevant connection methods as shown in the "Condensate installation diagrams" & BS6798.
- Pipework must be installed so that it does not allow spillage into the dwelling in the event of a blockage (through freezing)
- All internal burrs should be removed from the pipe work and any fittings.

In order to minimise the risk of freezing during prolonged very cold spells, one of the following methods of terminating condensate drainage pipe should be adopted.

### Internal Drain Connections

Wherever possible, the condensate drainage pipe should be routed to drain by gravity to a suitable internal foul water discharge point such as an internal soil and vent stack or kitchen or bathroom waste pipe etc.

Refer to Fig.  
1 & 2

### Condensate Pump

Where gravity discharge to an internal termination is not physically possible or where very long internal pipe runs would be required to reach a suitable discharge point, a condensate pump of a specification recommended by the boiler or pump manufacturer should be used terminating into a suitable internal foul water discharge point such as an internal soil and vent stack or internal kitchen or bathroom waste pipe etc.

Refer to Fig.  
3

### External Drain Connections

The use of an externally run condensate drainage pipe should only be considered after exhausting all internal termination options as described previously. An external system must terminate at a suitable foul water discharge point or purpose designed soakaway. If an external system is chosen then the following measures must be adopted:

The external pipe run should be kept to a minimum using the most direct and "most vertical" route possible to the discharge point, with no horizontal sections in which condensate might collect.

- For connections to an external soil/vent stack. Insulation measures as described should be used.

Refer to Fig.  
4

- When a rainwater downpipe is used, an air break must be installed between the condensate drainage pipe and the downpipe to avoid reverse flow of rainwater into the boiler should the downpipe become flooded or frozen.

Refer to Fig.  
5

- Where the condensate drain pipe terminates in a purpose designed soakaway (see BS 6798) any above ground condensate drain pipe sections should be run and insulated as described above.

Refer to Fig.  
6

- Where the condensate drain pipe terminates over an open foul drain or gully, the pipe should terminate below the grating level, but above water level, to minimise "wind chill" at the open end. The use of a drain cover (as used to prevent blockage by leaves) may offer further prevention from wind chill.

### Unheated Internal Areas

Internal condensate drain pipes run in unheated areas, e.g. lofts basements and garages, should be treated as external pipe.

Ensure the customer is aware of the effects created by a frozen condensate and is shown where this information can be found in the user manual.

**Note.** Please check current HHIC condensate discharge guidance available via the Gas Safe Registered Technical Bulletins List.





### 2.22 CONNECTIONS

Ensure all boss blanking plugs are removed before connecting hardware.

#### WATER CONNECTIONS

The boiler flow and return pipes are supplied fitted to the boiler and ready for top connection.

##### Top Connection

Connect the system pipework to the boiler flow and return pipes using compression fittings.

An optional stand-off kit is available where system pipework needs to be taken downwards.

#### GAS CONNECTION

**! IMPORTANT** The gas service cock is sealed with a non-metallic blue fibre washer, which must not be overheated when making capillary connections.

For details of the position of the gas connection:

Refer to Gas Supply  
1.10

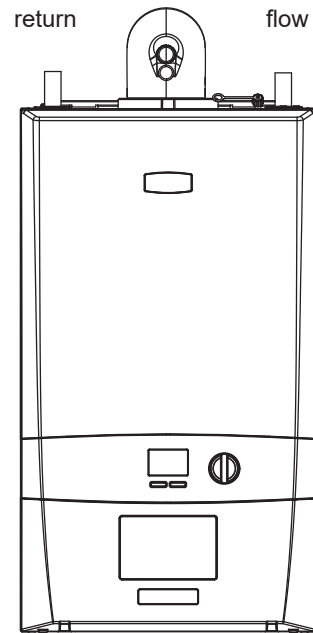

All isolation handles are shown in the open position.

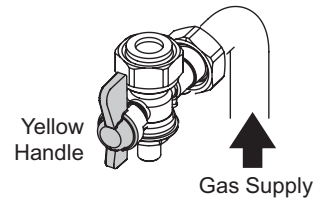

### 2.23 ELECTRICAL CONNECTIONS

**⚠ WARNING:** This appliance must be earthed

A mains supply of 230 V ~ 50Hz is required.

The fuse rating should be 3 A. All external controls and wiring must be suitable for mains voltage.

Wiring external to the boiler **MUST** be in accordance with the current IET (BS7671) Wiring Regulations and any local regulations.

Wiring should be 3 core PVC insulated cable, not less than 0.75 mm<sup>2</sup> (24 x 0.2 mm), and to BS 6500 Table 16.

The mains supply to the boiler and system wiring centre shall be through one common fused double pole isolator. For heating systems, and where practicable replacement boiler installations, the isolator shall be situated adjacent to the appliance.

**Note.** The appliance must be wired with a permanent live supply or the boiler warranty will be invalid.

### 2.24 INSTALLER WIRING

The boiler must be connected to a permanent live supply which must **NOT** be switched by thermostats / programmers.

To install the mains cable;

1. Isolate the mains supply to the boiler.
2. Remove the front panel.

Refer to Section  
3.4

3. Swing the control box down into the service position, unclip and swing back the installer wiring cover to latch into the retaining clips.

4. Route incoming cable through a grommet in the bottom panel, (note that the grommets are "blind" and will require puncturing) and securing using the strain relief.
5. Connect the mains cable to the terminal block as shown.
6. Close the installer wiring cover ensuring that it is located correctly and that the cable is retained into the strain relief as shown.
7. Swing the control box back up into the operating position and re-fit the front panel ensuring a good seal is made.

## 2.25 INSTALLER WIRING - CONTINUED

When making the mains electrical connections to the boiler it is important that the wires are prepared in such a way that the earth conductor is longer than the current carrying conductors, such that if the cord anchorage should slip, the current carrying conductors become taut before the earthing conductor.

Installer Connections (LHS)

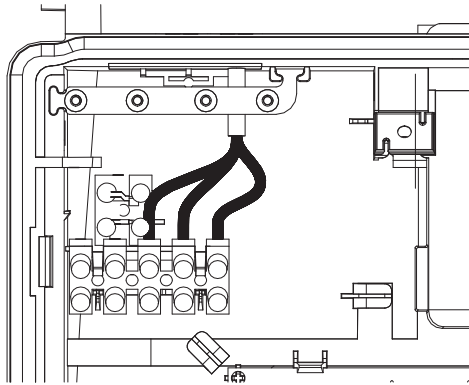

Installer Connections (RHS)

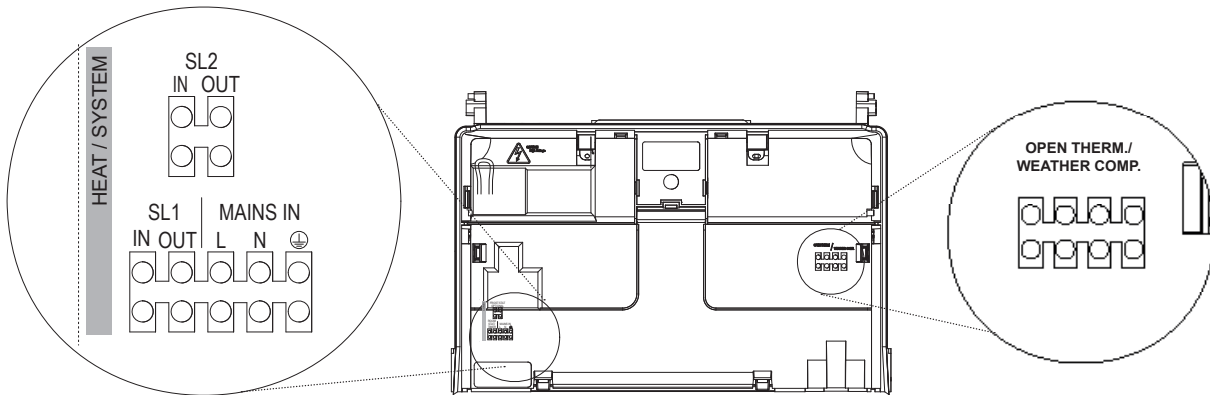
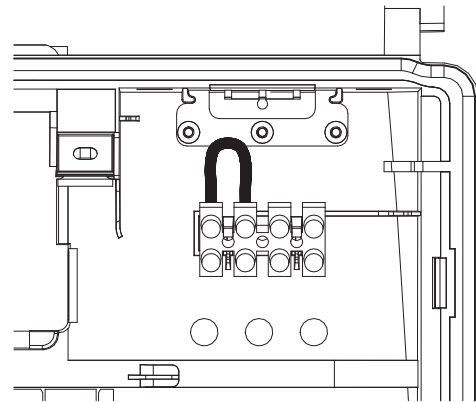

### Pump Overrun

Logic Heat<sup>2</sup> boilers do not have an integral pump and depend on a system pump for water circulation. There are occasional overhear lockout issues due to having no pump overrun, when fitted on systems which do not allow natural circulation to dissipate any excess residual heat.

Overheat lockout issues typically occur when the flow and return pipes do not have a sufficient vertical length from the boiler, but turn 90° and run horizontally close to the top of the boiler.

A pump overrun kit (221792) is available to provide extra protection from overheating and is recommended on systems most at risk.

This pump overrun kit contains a capacitor which allows the water to circulate through the boiler 4 minutes after the boiler is switched off. This process will remove residual heat that may otherwise trip the overheat thermostat.

### Frost Protection

If parts of the pipework run outside the house or if the boiler will be left off for more than a day or so then a frost thermostat should be wired into the system.

The frost thermostat should be sited in a cold place but where it can sense heat from the system.

**Note.** If the boiler is installed in a garage it may be necessary to fit a pipe thermostat, preferably on the return pipework.

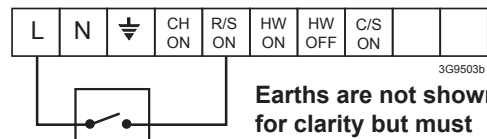

**Earths are not shown for clarity but must never be omitted.**

## Section 2 - Installation

### 2.26 INSTALLER WIRING - CONTINUED

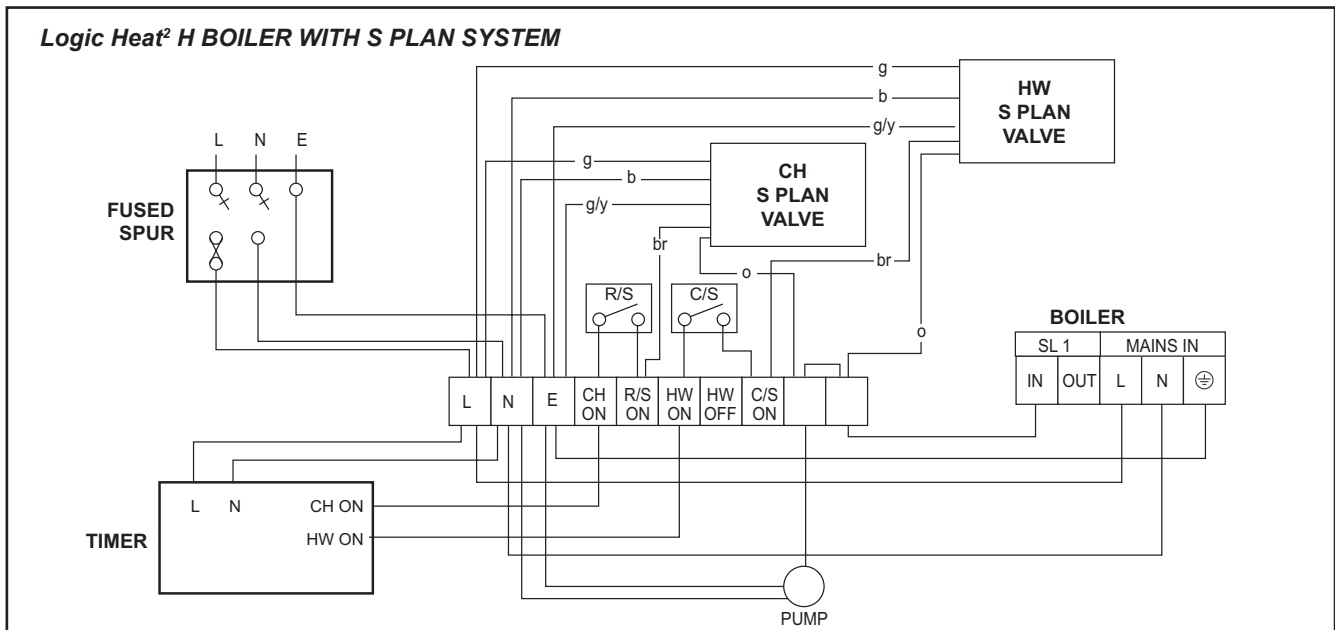
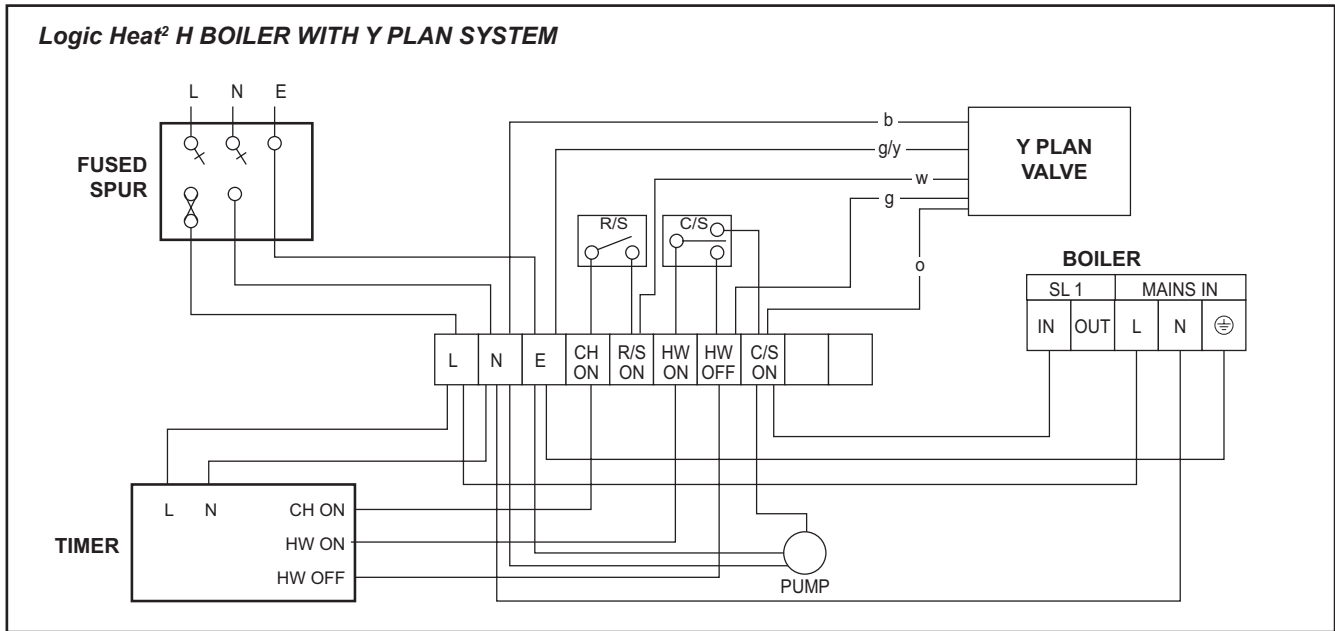

## Section 2 - Installation

### 2.27 INSTALLER WIRING - CONTINUED

**Logic Heat<sup>2</sup> H BOILER WITH Y PLAN SYSTEM (with outside sensor OR 2x Switched Live Operation)**

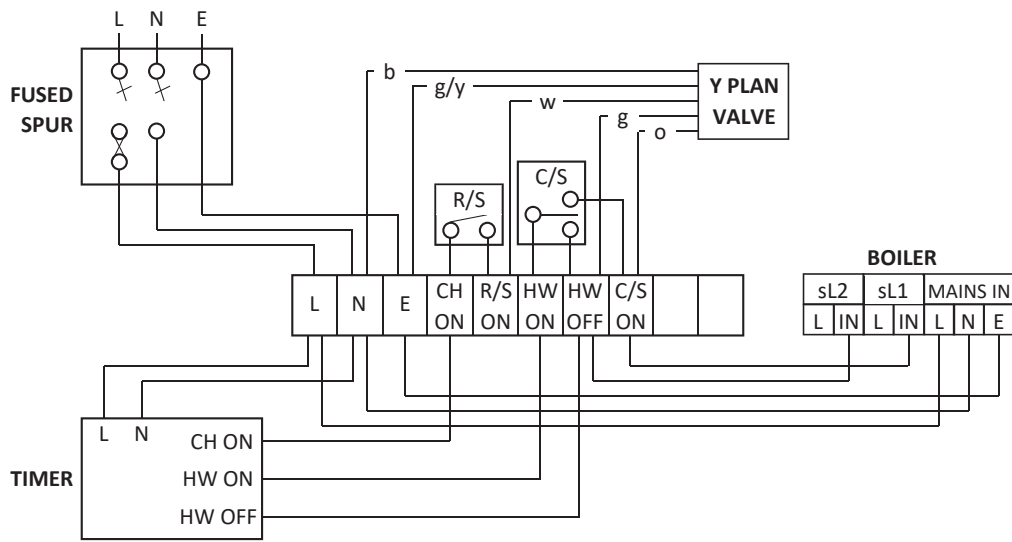

**Logic Heat<sup>2</sup> H BOILER WITH S PLAN SYSTEM (with outside sensor OR 2x Switched Live Operation)**

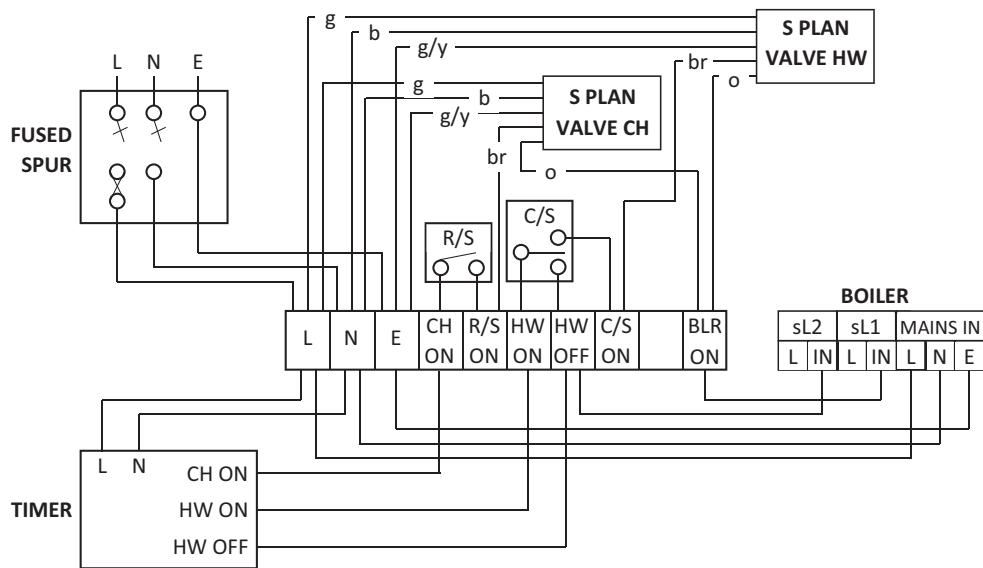

## 2.28 PUMP OVERRUN - INSTALL

Refer to Section 2.25

1. Isolate the power.
2. Mount the flanged box near to the wiring centre.
3. In the wiring centre, disconnect the Pump Live and move it to a spare terminal.
4. Connect the pump overrun box leads as follows:
  - BLACK - to the terminal that you have just removed the pump live from.
  - RED - to the Pump Live spare terminal.
  - BROWN - to supply live.
  - BLUE - to supply neutral.
5. Power up and test.

The pump overrun time is set to 4 minutes.

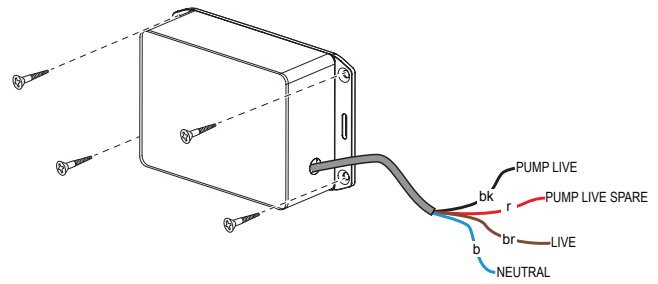

Pump Overrun Unit

## 2.29 ELECTRICAL CONTROLS

### 2x Switched Live Operation

For a boiler without an Outside Sensor connected, it can be set to operate with 2x Switched Live control via the menu.

When this feature is turned on:

- sL1 is the CH/DHW demand input:
  - 0V = CH/DHW demand **Off**, 240V = CH/DHW demand **On**
- sL2 becomes the DHW demand input:
  - 0V = DHW demand **On**, 240V = DHW demand **Off**

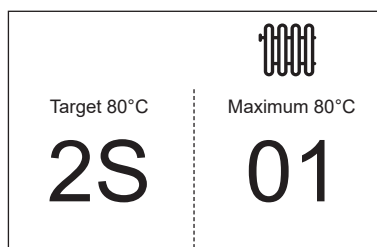

1x Switched Live Mode selected.

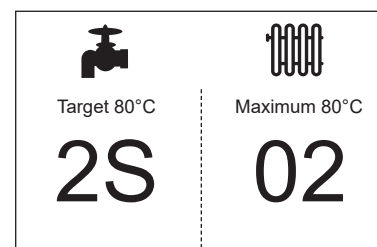

2x Switched Live Mode selected.

2.30 WIRING DIAGRAM

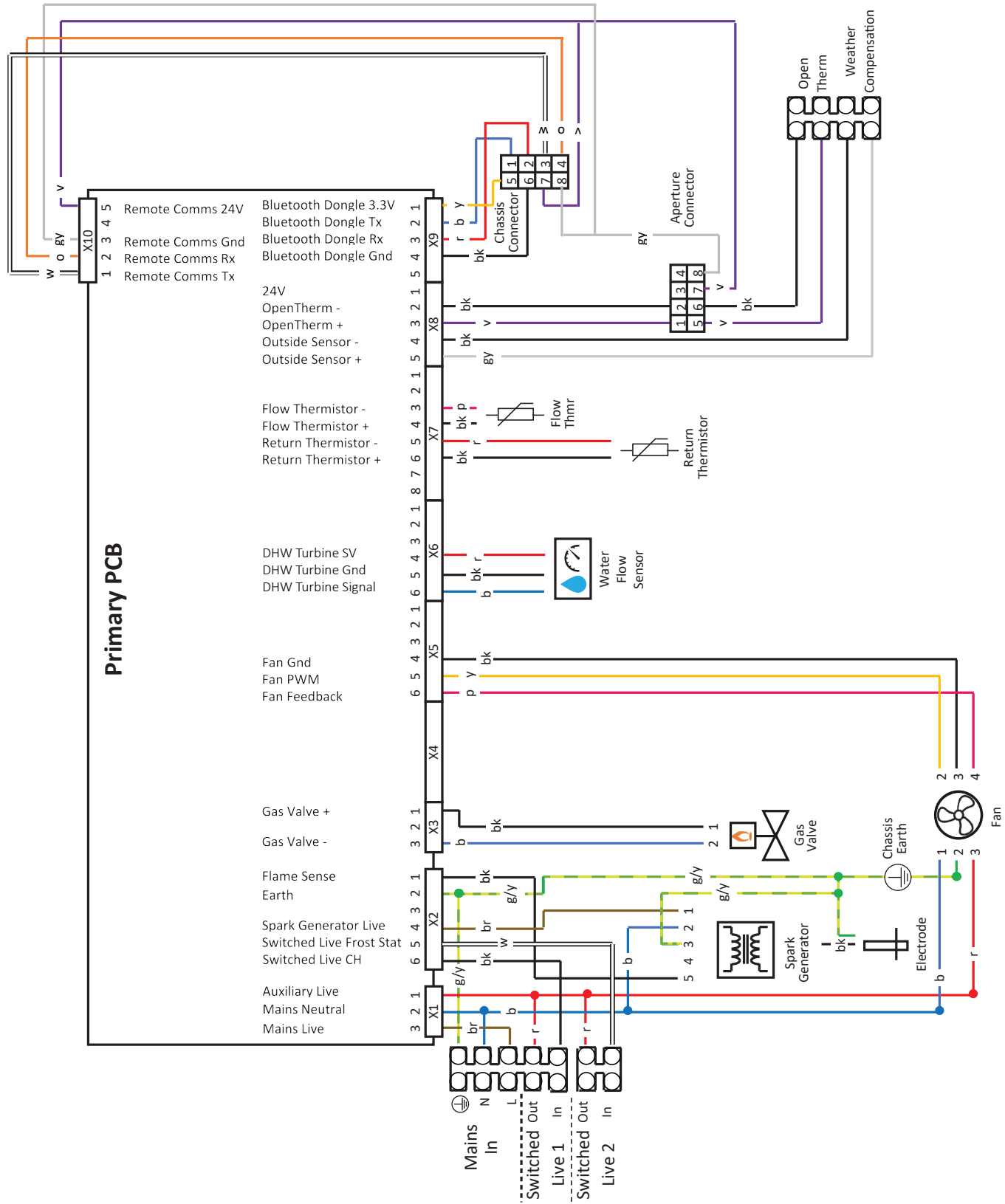

- Key**
- bk: Black
  - gy: Grey
  - r: Red
  - g: green
  - b: blue
  - br: brown
  - g/y: green/yellow
  - o: orange
  - p: pink
  - v: violet
  - y: yellow
  - w: white

## 2.31 COMMISSIONING AND TESTING

### A. Electrical Installation

**WARNING:** Electrical safety checks should be carried out by a qualified person.

Complete preliminary electrical system checks.

#### General

The combustion for this appliance has been checked, adjusted and preset at the factory for operation on the gas type defined on the appliance data plate.

Do not adjust the air / gas ratio valve.

Check the following:

1. The boiler has been installed in accordance with these instructions.
2. The integrity of the flue system and the flue seals, as described in the Flue Installation Section.

Proceed to put the boiler into operation as follows:

1. Check the operational gas inlet pressure.
2. Set up the boiler to operate at maximum rate by opening hot tap to maximum flow.
3. With the boiler operating in the maximum rate condition check that the operational gas pressure at the inlet gas pressure test point complies with the requirements.
4. Ensure that this inlet pressure can be obtained with all other gas appliances in the property working.

Refer to Gas Supply  
page 10

### Intelligent Load Optimisation

Intelligent Load Optimisation is a feature enabled on the boiler to reduce cycling on and off and behaves as follows.

With an active CH demand (e.g. Switched Live on), if the Flow Temperature reaches the CH Target + 4°C then the boiler switches off and the Intelligent Load Optimisation function is activated. This can happen if the system load is less than the minimum output of the boiler.

If the CH demand is still active, when the boiler lights again it immediately modulates down to the minimum rate over 60s and then stays at the minimum for 10 minutes.

Normal operation resumes after either of the following conditions are met:

- After 10 minutes of operation at minimum rate.
- The CH demand is off for more than 1 hour.

### B. Gas Installation

**WARNING:** Open windows, doors and extinguish flames before starting the next steps. Do not smoke.

1. The whole of the gas installation, including the meter, should be inspected and tested for tightness and purged in accordance with the recommendations of BS.6891.
2. Purge air from the gas installation by the approved methods only.

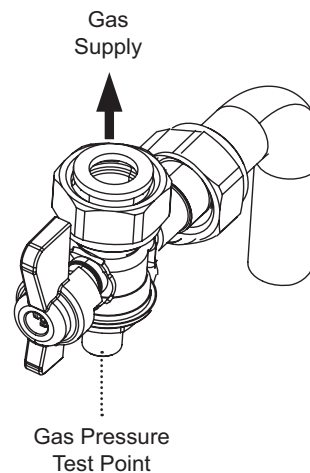

**IMPORTANT:** A condition of the manufacturer's warranty is that Benchmark commissioning process is completed. The flow chart is provided on page 61.



## 2.32 INITIAL LIGHTING

### Legend

- A. Temperature Knob
- B. Mode Button
- C. Boiler Status Display
- D. Burner On indicator
- E. Restart Button
- H. Gas Inlet Pressure Test Point
- J. Gas Service Cock

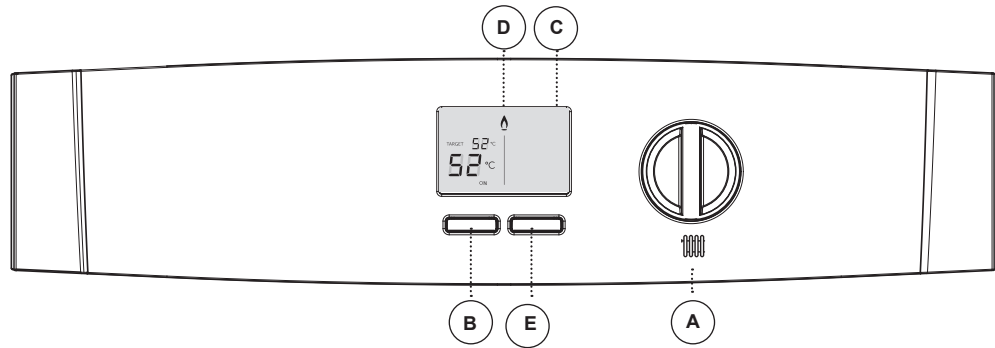

**IMPORTANT** Do not operate the appliance before it has been fully vented of air. If it is necessary to operate the pump, do so with the gas service cock turned off.

The boiler incorporates a fan overrun cycle which must not be interrupted by isolation of electricity supply.

1. Check that the system has been filled and that the boiler is not airlocked.
2. Refit the boiler front panel.

Refer to Section 3.4

3. Check that the drain valve is closed.
4. Press the Mode button (B) until Off is shown at the bottom of the screen (boiler off)
5. Switch the electrical supply OFF
6. Check that the gas service cock (J) is OPEN.
7. Slacken the screw in the inlet pressure test point (H) and connect a gas pressure gauge via a flexible tube.
8. Switch the electricity supply ON and check all external controls are calling for heat.

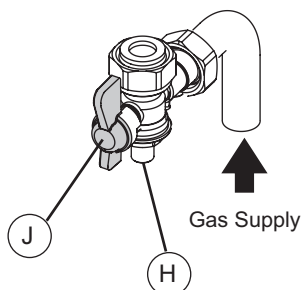

9. Press the Mode button (B) until Off is not shown at the bottom or the screen. Turn the Temperature Knob until 80°C is shown. The boiler control will now go through its ignition sequence until the burner is established.
10. If the boiler does not light then after 5 attempts the boiler will lock out and display fault code L 02.
11. Press the Restart Button (E). The boiler will repeat its ignition sequence. If Restart occurs 5 times within 15 minutes then L 0C will be shown. If power is removed this will be restarted.
12. When the burner is established the flame symbol (D) will be shown on the display and the current flow temperature will be shown in large digits.
13. Ensure that with the burner on, the dynamic gas pressure is able to obtain maximum output. Refer to Table 2.
14. Replace the screw in the inlet pressure test point and check for gas soundness.

**IMPORTANT** The gas input to the burner is regulated by the gas valve according to the air flow produced by the fan. It is NOT user-adjustable. Any interference to sealed settings on the gas valve will adversely affect operation and render our warranty void.

Refer to Gas Supply page 10

**Note.** The boiler incorporates a fan overrun cycle which MUST NOT be prematurely interrupted by isolation of the mains electricity supply.

### 2.33 THE DISPLAY

The user control has one display to inform the user about the status of the boiler. The display shows the status of the flame. If no flame is detected then flame symbol will not be visible. When the flame is detected the flame symbol will be visible permanently.

Below is a list with display function.

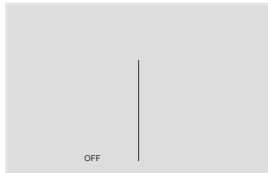

**Boiler Off Mode**  
Press the Mode button to enable CH.



**Boiler On Mode, no Heat Demand**

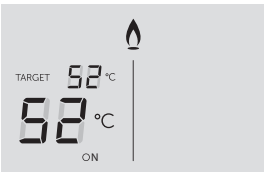

**Boiler is active for Central Heating**

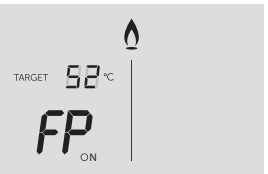

**Boiler is active for boiler frost protection:** operates if the ambient temperature is below 5°C until it reaches 19°C.

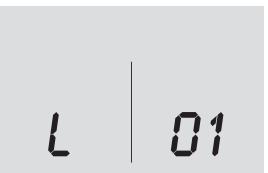

**Boiler is in Lockout for a specific error.** Display will show a number after the "L" to indicate which error is detected

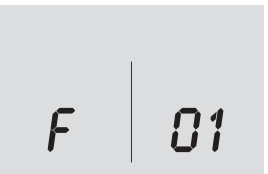

**Boiler has a fault for a specific error.** Display will show a number after the "F" to indicate which error is detected.

### 2.34 GENERAL CHECKS

**Make the following checks for correct operation:**

#### CENTRAL HEATING (CH) MODE

1. Ensure that the external controls are calling for heat. The display should show:-

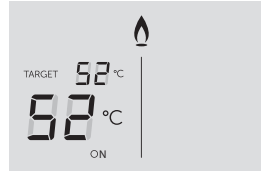

2. **Gas Rate**

Check the boiler gas rate when the boiler is at maximum output.

Check at the gas meter, with no other appliance in use. Refer to Table 2 for gas rates.

3. Set the external controls to OFF. The burner should go off and the pump continue to run for two minutes.

The display should show:

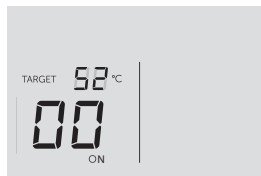

4. Check the correct operation of the timer (if fitted) and all other system controls. Operate each control separately and check that the main burner responds.

## 2.35 GENERAL CHECKS CONT. - WATER CIRCULATION

### WATER CIRCULATION SYSTEM

1. With the system COLD, check that the initial pressure is correct to the system design requirements.  
For pre-pressurised systems, this should be 1.0 bar.
2. With the system HOT, examine all water connections for soundness. The system pressure will increase with temperature rise but should not exceed 2.5 bar.
3. With the system still hot, turn off the gas, water and electricity supplies to the boiler and drain down to complete the flushing process.

**Note.** A flushing solution should be used during the flushing procedure. Flushing solutions: Fernox Superfloc, Sentinel X300 (new systems) or X400 (existing systems).

Refer to Section  
1.22

4. Refill and vent the system, add inhibitor (Refer to section 1.20), clear all air locks and again check for water soundness.
5. Reset the system initial pressure to the design requirement.
6. Balance the system.

Refer to Section  
1.21

7. Check the condensate drain for leaks and check that it is discharging correctly.
8. Finally, set the controls to the User's requirements.

### WATER TEMPERATURES

Temperatures can be selected using the Temperature Knob (A)

	No Outside Sensor	Outside Sensor Connected
Temp Knob Setting	CH Flow Temp °C	Nominal Room Temp. °C
Max	80	30
Min	30	10

## 2.36 RESTART PROCEDURE

### Legend

- A. Temperature Knob
- B. Mode Button
- C. Boiler Status Display
- D. Burner On indicator
- E. Restart Button

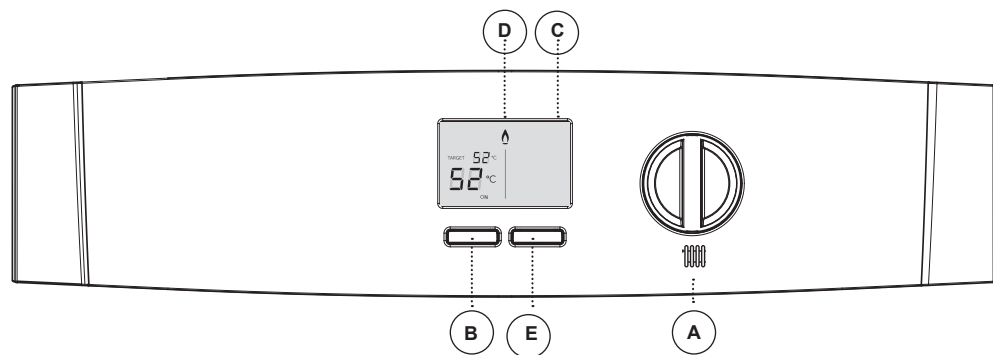

If an L code is shown on the display then the boiler can be restarted by pressing the Restart button (E).

### 2.37 ACCESSING THE INSTALLER MODE

To access Installer Mode, press the “MODE” and “RESTART” buttons together for more than 5s.

1. The last 3 faults will be shown. See Frame 4.1 for Fault Code descriptions.

2. “PH” will be shown.

Press “MODE”.

3. “SH” will be shown.

To run the burner at maximum rate press “RESTART”, otherwise press “MODE”.

4. “SL” will be shown.

To run the burner at minimum rate press “RESTART”, otherwise press “MODE”. Note that the burner will initially run at maximum rate for 30s before ramping down to minimum over 1 minute.

5. “UF” will be shown.

Press “MODE”

6. “dU” will be shown.

Press “MODE”.

7. “P1” will be shown.

To set the minimum CH pump speed to 100% press “RESTART”, otherwise press “MODE”.

8. “P7” will be shown.

Press “MODE”.

9. “SE” will be shown.

For service timer function refer to separate instructions. Press “MODE” to exit.

### 2.38 HANDING OVER

**After completing the installation and commissioning of the system the installer should hand over to the householder by the following actions:**

1. Hand the User Instructions to the householder and explain his/her responsibilities under the relevant national regulations.
2. Explain and demonstrate the lighting and shutting down procedures.
3. The operation of the boiler and the use and adjustment of all system controls should be fully explained to the householder, to ensure the greatest possible fuel economy consistent with the householder requirements of both heating and hot water consumption. Advise the user of the precautions necessary to prevent damage to the system and to the building. In the event of the system remaining inoperative during frosty conditions.
4. Explain the function and the use of the boiler heating and domestic hot water controls.
5. Explain the function of the boiler fault mode. Emphasise that if a fault is indicated refer to “Fault Codes” in the User Guide.
6. Explain and demonstrate the function of timers and temperature controls, radiator valves etc. for the economic use of the system.

7. Explain boiler restart procedure.

Refer to Section  
**2.36**

8. After installation and commissioning please complete the Commissioning Checklist before handover to the customer.



Refer to  
**Page 66**

**! IMPORTANT**

9. A comprehensive service should be carried out annually. Stress the importance of regular servicing by a Gas Safe Registered Engineer.
10. Inform the householder of the guarantee/registration found within the envelope pack and then requirement to register it to receive the full benefit of the warranty.

## 3.1 SERVICING SCHEDULE

**⚠ WARNING:** Servicing can only be carried out by Gas Safe Registered Engineers  
 Always turn OFF the gas supply at the gas service cock, and switch OFF and disconnect the electricity supply to the appliance before servicing  
**Combustion testing must be carried out by a competent person using a combustion analyser conforming to BS EN 50379-3:2012.**

To ensure the continued safe and efficient operation of the appliance it is recommended that it is checked at regular intervals and serviced as necessary. The frequency of servicing will depend upon the installation condition and usage but should be carried out at least annually.  
 For the latest copy of literature, visit our website [idealheating.com](http://idealheating.com).

### PRELIMINARY INSPECTION

1. Light the boiler and carry out a pre-service check, refer to the fault finding chart.
2. Check the flue terminal (and terminal guard if fitted) for damage and obstruction.
3. Check combustion by connecting the flue gas analyser to the flue gas sampling point as shown in the diagram and measure CO and CO<sub>2</sub> at maximum rate. To set the boiler to Maximum and Minimum heat inputs

Refer to  
Page 60

If the CO / CO<sub>2</sub> ratio is greater than 0.004 please proceed to "Cleaning Procedure".  
 If the CO / CO<sub>2</sub> ratio is less than 0.004 please proceed to "Check Procedure".

### CHECK PROCEDURE

1. Check all water and gas joints for signs of leakage. Remake any suspect joints ensuring a gas tightness check is carried out if applicable and the water system is correctly refilled, vented and re-pressurised.
2. Proceed to "IMPORTANT".

### ⚠ IMPORTANT

1. If, for any reason, the condensate trap has been removed, ensure the trap is refilled with water before re-assembling.
2. After completing the servicing or exchange of components always ensure all gas valve connections are gas tight with a gas soundness check up to the gas control valve.
3. When work is complete the front panel MUST be correctly refitted, ensuring that a good seal is made.
4. Complete the service section in the Benchmark Commissioning Checklist.

### GENERAL

During Servicing, and after any maintenance or change of part of the combustion circuit, the following must be checked:

- The integrity of the flue system and the flue seals.
- The integrity of the boiler combustion circuit and the relevant seals.
- The operational (working) gas inlet pressure at maximum rate.
- The gas rate.
- The combustion performance.

### CLEANING PROCEDURE

1. Remove the casing.
2. Visually check the appliance for signs of leakage.
3. Remove the flue manifold.
4. Remove the fan.
5. Remove the burner.
6. Refit the sump outlet cover.
7. Clean the heat exchanger by pouring warm water across the whole heat engine to flush deposits taking care to avoid pouring water over the electrode.
8. Check the electrode for damage and clean using an abrasive cloth. Check and adjust the spark gap. Replace the electrode if damaged.
9. Clean out the sump outlet to ensure any debris is removed.
10. Remove and clean the condensate trap and re-prime the trap before re-installing.
11. Re-assemble the components in reverse order.
12. Carry out post service checks on the combustion circuit. See General.
13. Check the system water quality in accordance with BS7593:2019.
14. Complete the service record in the Benchmark section.

**Do not operate the boiler if the front panel is not fitted.**

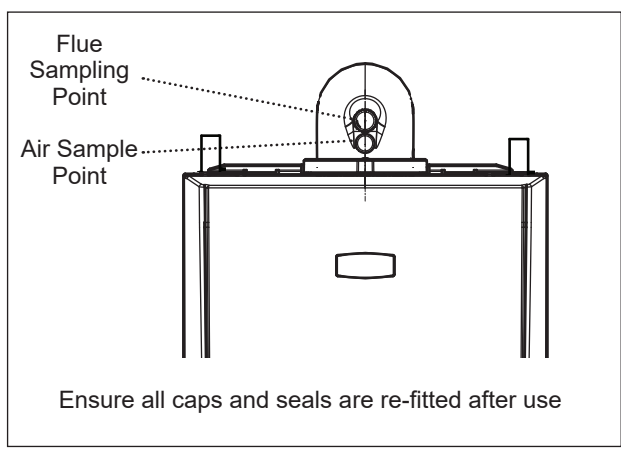

## Section 3 - Servicing

### 3.2 REMOVAL / REPLACEMENT OF COMPONENTS

**WARNING:** Do not operate the boiler without a front panel fitted

#### When replacing any component.

1. Isolate the electricity supply.
2. Turn off the gas supply.
3. Remove the boiler front panel.

Refer to Section  
3.4

4. Swing the control box down into its servicing position.

#### After removing / replacing any component.

5. Ensure all gas valve connections are gas tight with a gas soundness check up to the gas control valve.
6. Ensure all water connections are tight.
7. Test the appliance for correct and safe operation.

Refer to Section  
3.1 (General)

#### Notes.

1. In order to assist fault finding, the control panel has an LCD diagnostic display. The key to boiler fault conditions is shown in Section 4.
2. In order to replace components in Sections 3.17 and 3.19, it is necessary to drain the boiler.

Refer to Section  
3.3

### 3.3 DRAINING THE BOILER

Refer to Section  
3.2

#### CENTRAL HEATING CIRCUIT

1. Close all the CH water isolating valves on both the flow and return.
2. To drain the primary heat exchanger circuit: Remove rubber plug from the base and drain the boiler using the drain point.

Refer to Section  
3.19

3. After replacing any component on the boiler, remove the hose, close the drain valve and open all system isolating valves. Refit the rubber plug to the base to maintain case sealing. Repressurise before proceeding to check operation of the boiler.
4. Check that the boiler operates.

Refer to Section  
2.35 & 2.36

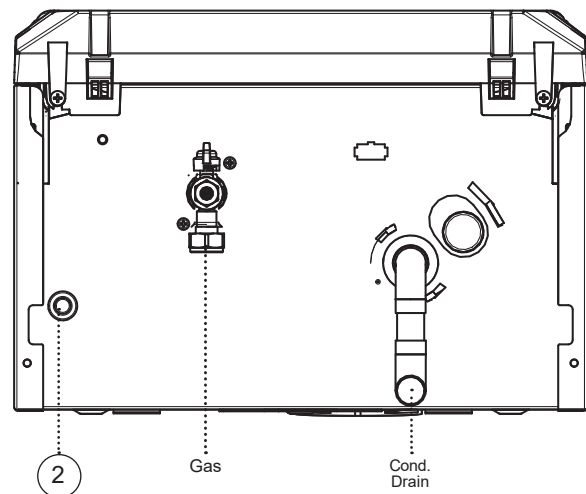

## Section 3 - Servicing

### 3.4 BOILER FRONT PANEL REMOVAL / REPLACEMENT

#### REMOVAL

1. Loosen the two screws retaining the front panel.
2. Pull the two clips down to disengage and pull panel forward and upward and remove.

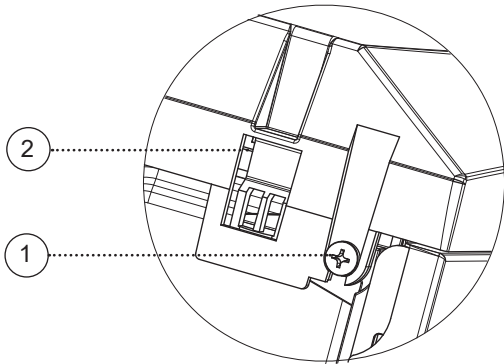

View from bottom of boiler

#### REPLACEMENT

3. Hook the panel onto the top retaining clips.
4. Push the panel until the 2 bottom spring clips engage ensuring the 1 knob and 2 buttons line up with the holes in the front panel.
5. Re-tighten the two retaining screws.

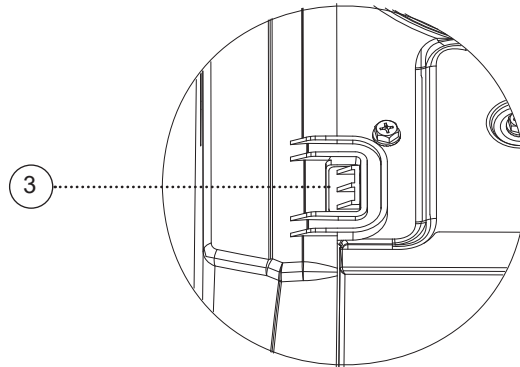

View from top of boiler

### 3.5 FLUE MANIFOLD REMOVAL / REPLACEMENT

1. Remove the two sump cover retaining screws
2. Remove the sump cover
3. Lift the manifold upwards to clear the sump
4. Move the manifold to the left and pull down to remove

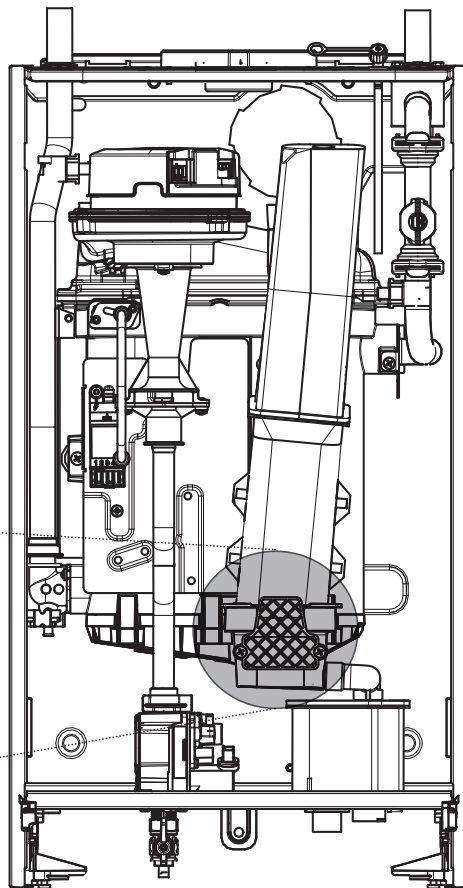
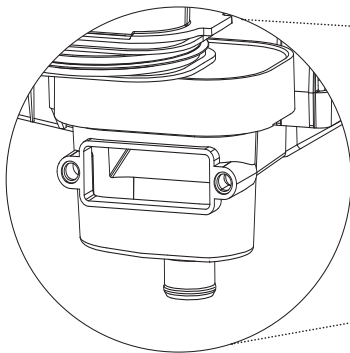



### 3.6 FAN AND VENTURI ASSEMBLY REMOVAL AND CLEANING

1. Disconnect the electrical leads from the fan.
2. Remove the clip from the gas control valve outlet and ease the pipe upwards. Rotate and then ease down to remove.
3. Remove the extended nut on the fan mounting bracket.
4. Lift off fan and venturi assembly.
5. Undo the two M4 screws and release the nozzle assembly.
6. Inspect the injector for blockage or damage.
7. Clean the outside of the injector and use a small flue brush to clean the injector hole. Do not use anything abrasive such as a file.
8. Remove the screw and twist venturi anti-clockwise to remove venturi assembly, noting the orientation of the venturi in relation to the fan body.
9. Inspect fan outlet sealing gasket and replace if necessary.
10. Ensure the venturi is free from dust/debris.
11. Check the 'O'-rings are fitted correctly to the gas outlet pipe replacing if any damage is witnessed.

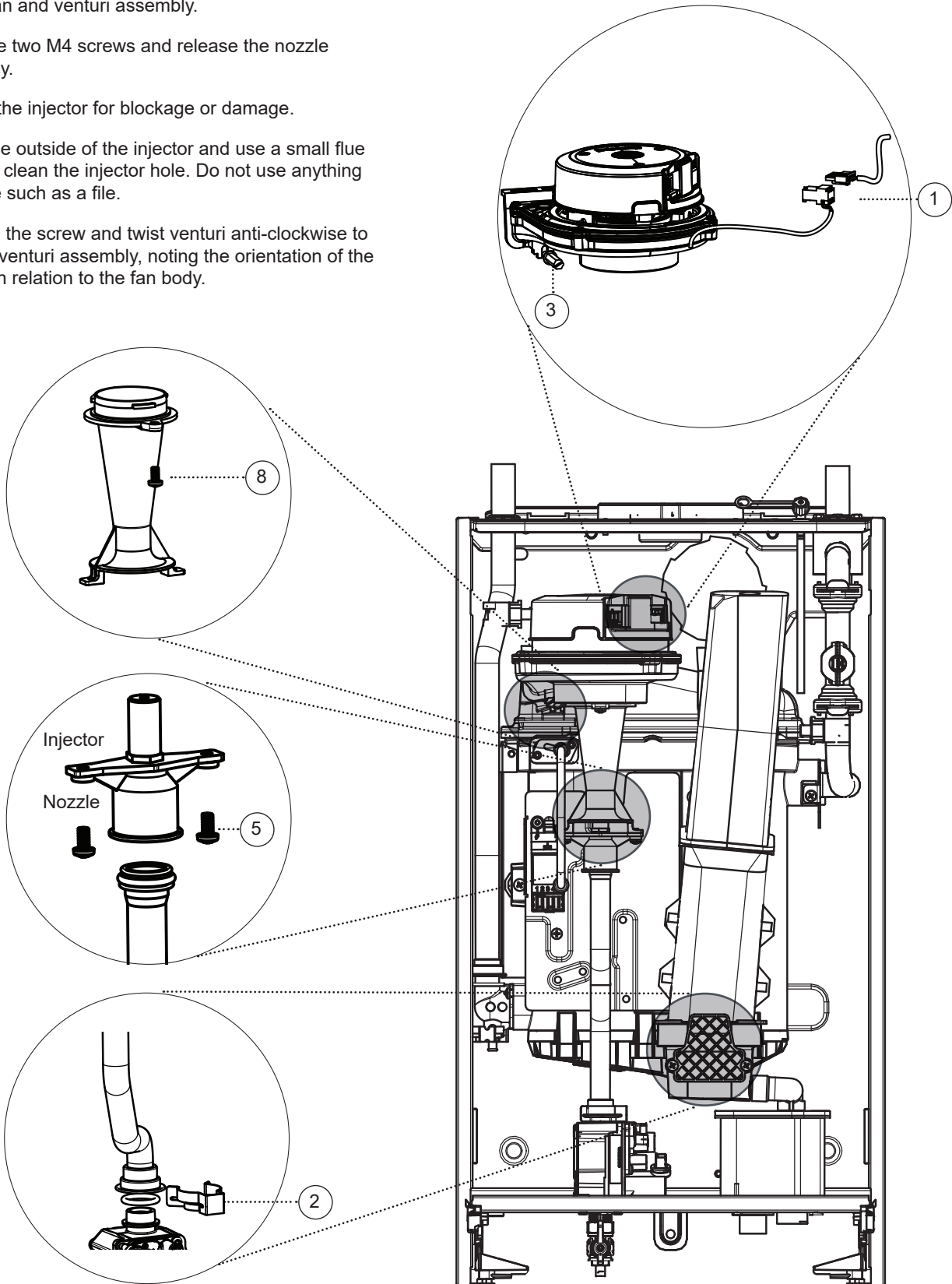

### 3.7 BURNER REMOVAL AND CLEANING

Refer to Section  
3.4

1. Remove the 2 burner front fixing screws and the 2 rear extended nuts.
2. Lift and pull forward the burner from the combustion chamber by holding the burner with two finger in the air inlet duct and your thumb on the top of the burner.
3. Tilt the burner towards yourself so that it raises to the vertical position.

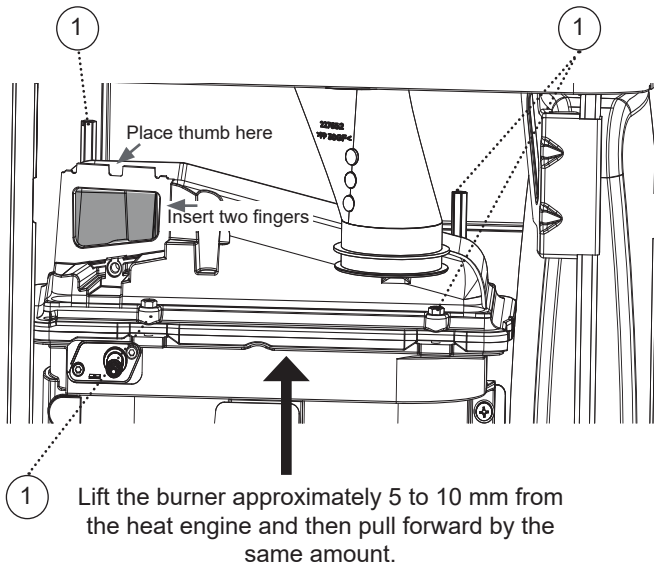

SCAN  
for video



4. Pull the burner out from the left hand side of the boiler once it is in the vertical position.

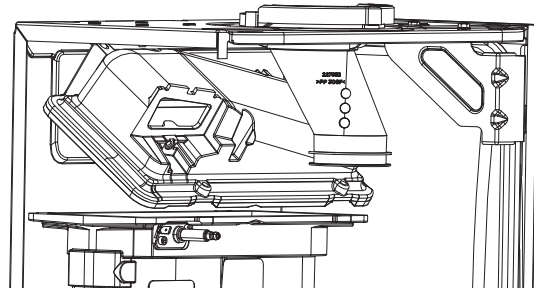

5. Carefully brush the ceramic burner with a soft non metallic bristle brush.

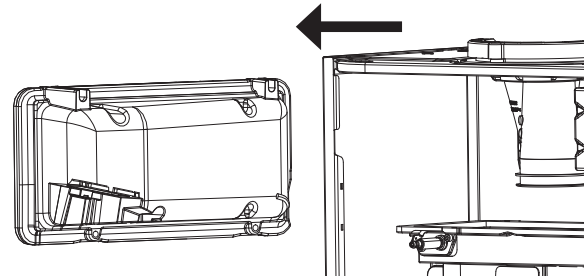

### 3.8 CLEANING THE HEAT EXCHANGER

1. Replace the sump cover prior to the water flush process.
2. Thoroughly flush the heat exchanger by pouring water into the top of the combustion chamber ensuring the full surface of the heat exchanger is cleaned. Avoid pouring water over the electrode.
3. Remove the sump cover and clean loose deposits from the sump.

4. Inspect the ignition/detection electrode. Ensure that it is clean and in good condition - replace if necessary.
5. Check that the ignition gap is correct.

Refer to Section  
3.9

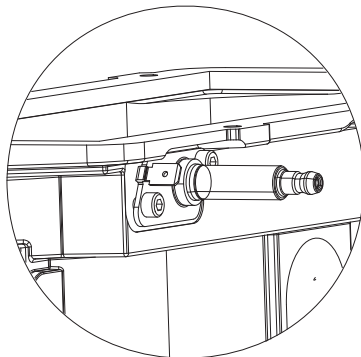

Combined Ignition Detection Electrode

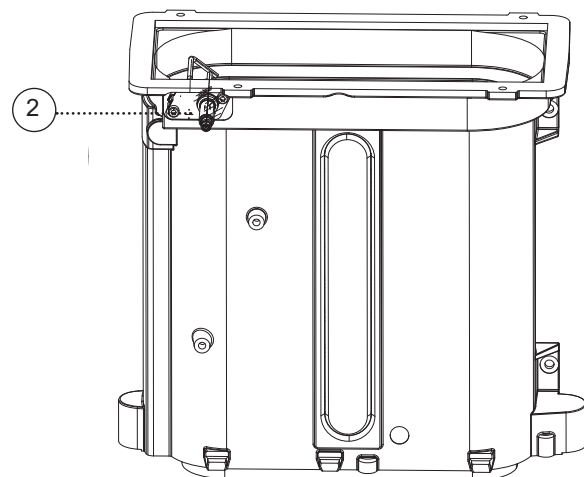

### 3.9 IGNITION / DETECTION ELECTRODE REPLACEMENT / INSPECTION

Refer to Section 3.2

1. Remove the fan.

Refer to Section 3.6

2. Remove the flue manifold.

3. Remove the burner.

Refer to Section 3.7

4. When servicing the boiler inspect the condition of the electrode and check the dimensions shown. If there is damage to the electrode continue to follow steps below for replacement.

5. Unplug the ignition lead from the electrode.

6. Remove the earth lead from the electrode.

7. Remove the 2 screws holding the electrode to the combustion chamber.

8. Remove the electrode.

9. Fit the new electrode, using the new gasket supplied. Check dimensions as shown.

Refer to Section 2.34 & 2.35

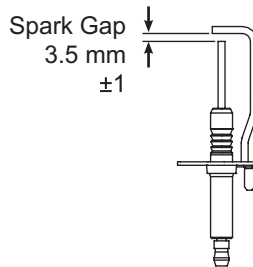

Ignition /Detection Electrode

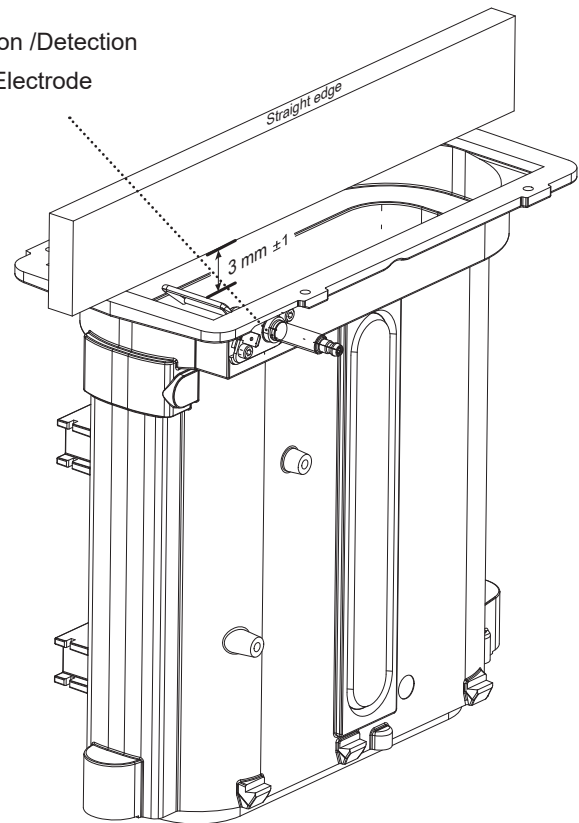

### 3.10 CLEANING THE CONDENSATE TRAP

**CAUTION:** Keep trap upright when removing

1. Pull off the rubber pipe at the sump drain.
2. Disconnect the condensate drain pipe.
3. Turn the trap clockwise to disengage and lift to remove.
4. Clean and fill trap with water.
5. Reassemble by doing the opposite in steps 3 - 1.

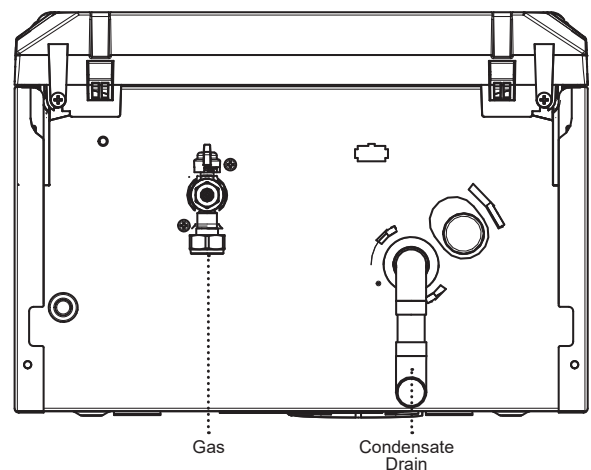
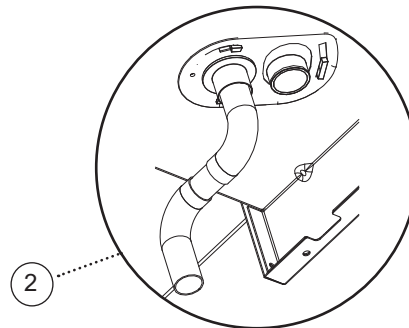
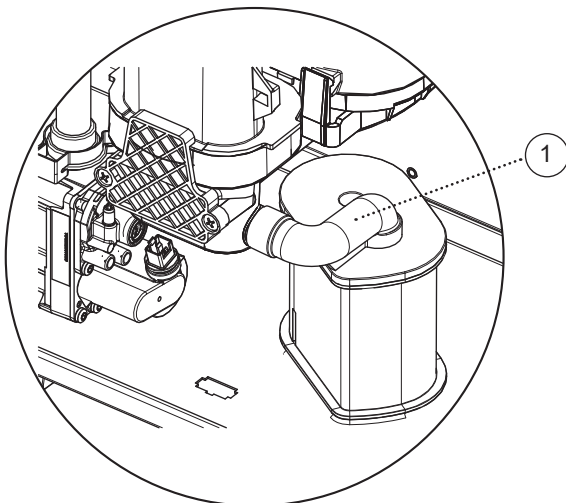

## Section 3 - Servicing

### 3.11 FLOW & RETURN THERMISTOR REPLACEMENT

Refer to Section  
3.2

1. Disconnect the electrical leads from the thermistors.
2. Unclip the flow thermistor from the flow pipe and withdraw it from the boiler.
3. Unclip the return thermistor from the return pipe and withdraw it from the boiler.

4. Reconnect the electrical lead to the new thermistors and reassemble in reverse order, ensuring that the thermistor is securely fitted to the pipe on the thermistor locator tab as shown.
5. Check the operation of the boiler.

Refer to Section  
2.35 & 2.36

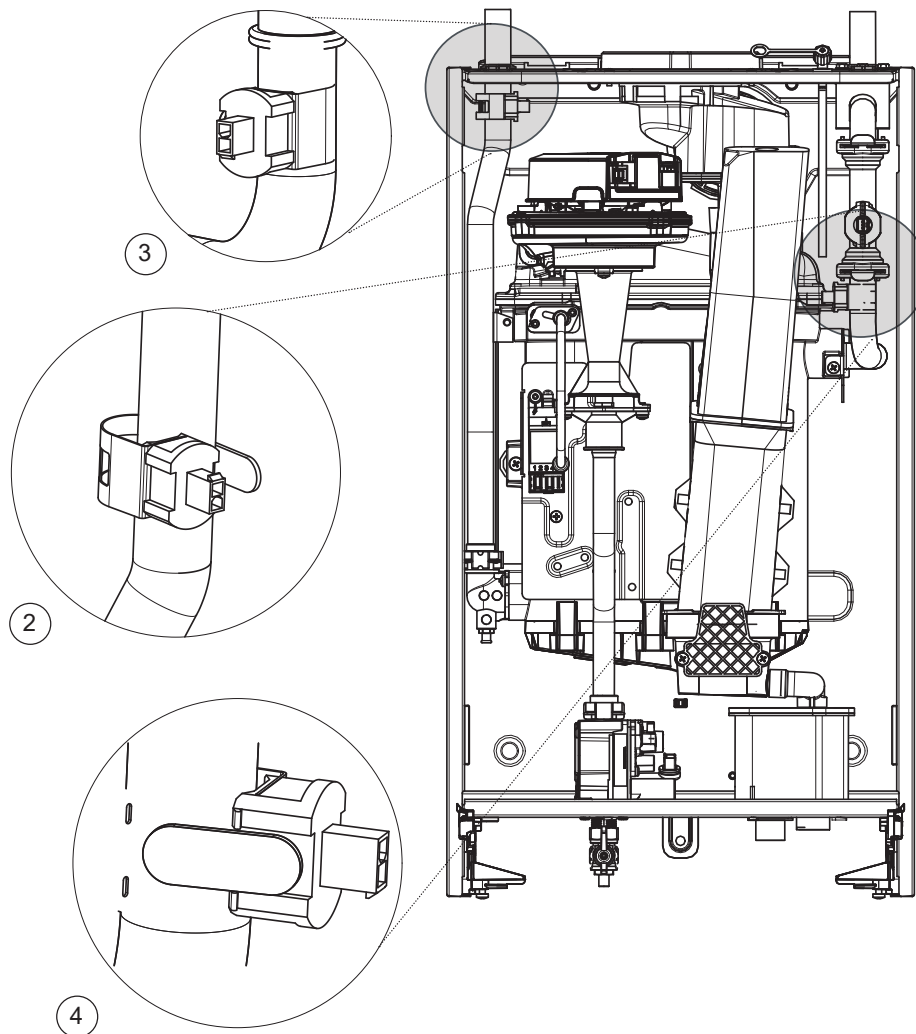

SERVICING

### 3.12 BURNER INJECTOR REPLACEMENT

Refer to Section  
3.7

### 3.13 BURNER REPLACEMENT

Refer to Section  
3.2 & 3.7

SCAN  
for video



### 3.14 SPARK GENERATOR REPLACEMENT

Refer to Section  
3.2

1. Disconnect the leads from the spark generator.
2. Gently push up the generator to release the bottom clip from the gas valve mounting bracket.
3. Lift the spark generator up and out of the bottom retaining location point.

4. Fit the new spark generator and re-assemble ensuring that the the earth lead is replaced.
5. Check the operation of the boiler..

Refer to Section  
2.35 & 2.36

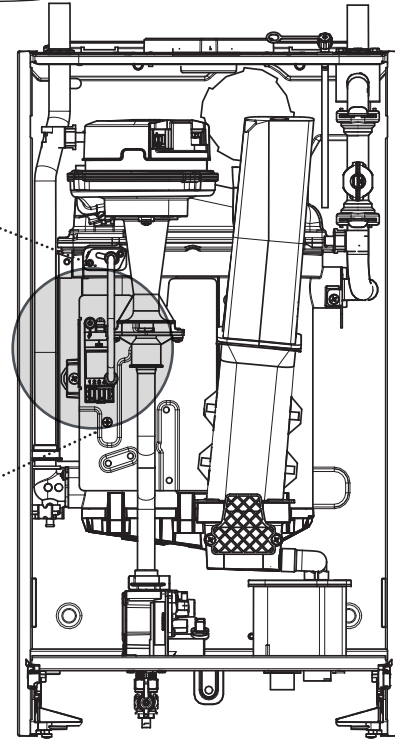
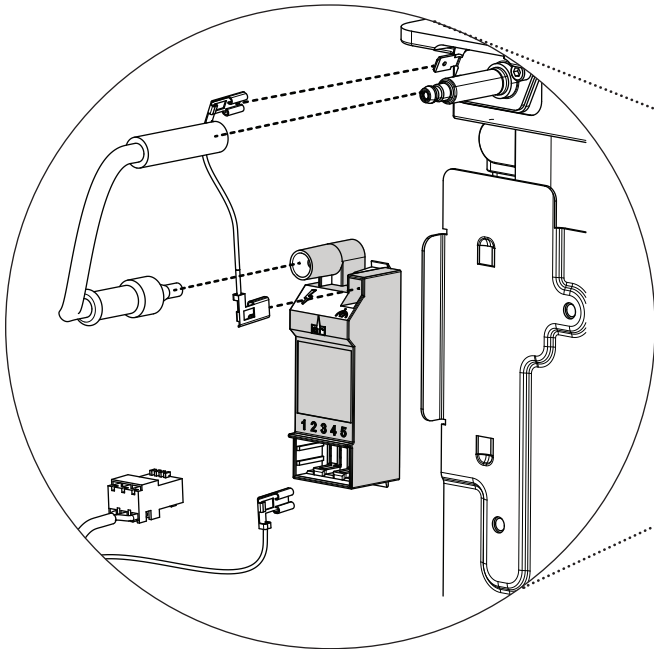

### 3.15 GAS CONTROL VALVE REPLACEMENT

Refer to Section  
3.2

1. Unplug the electrical lead connection from the gas control valve.
2. Remove the outlet gas valve clip and slide the pipe upwards.
3. Undo the gas inlet pipe union at the inlet to the gas valve.
4. Undo the two screws fixing the gas valve to the chassis base and lift the gas valve upwards.
5. Fit the new gas control valve ensuring that the 'O' ring and sealing washer are in place and reconnect gas and electrical connections.
6. Ensure all gas valve connections are gas tight with a gas soundness check up to the gas control valve.

Refer to Section  
2.35 & 2.36

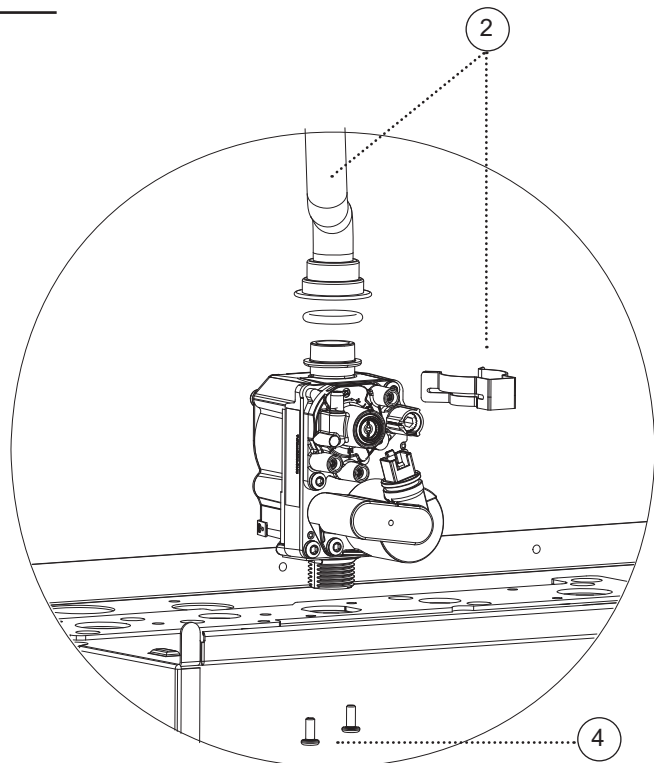

### 3.16 CONDENSATE TRAP REPLACEMENT / CLEANING

Refer to Section  
3.2

### 3.17 FLOW SWITCH REPLACEMENT

Refer to Section  
3.2

1. Drain the boiler.

Refer to Section  
3.3

2. Pull off the electrical connection.
3. Turn the retaining collar anti-clockwise and pull the head from the housing.
4. Fit the new water flow switch head, ensuring the electrical lead connections wires point to the left as shown.

Refer to Section  
2.35 & 2.36

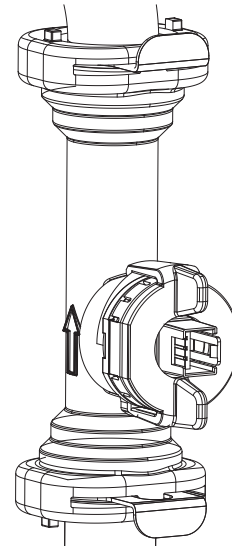

SERVICING

### 3.18 PRIMARY PCB REPLACEMENT

**WARNING:** It is critical that the correct boiler size and fuel type is entered in to the boiler.

**CAUTION:** Fit the earth strap provided with the PCB to your wrist and secure to a suitable earth on the boiler chassis.

Refer to Section  
3.2

1. Carefully release the six retaining clips and remove control box cover.
2. Unplug all lead connections to the PCB.
3. Spring out the four side retaining clips and pull the PCB upwards to clear the corner retaining posts.
4. Take the new PCB and re-connect all plug connections.
5. Reassemble in reverse order.
6. Switch mains power on, wait for "uP" to be shown.
7. Simultaneously press Mode & Restart buttons so that "oF" is shown.
8. Switch mains power off and wait for 5s.
9. Switch mains power on, wait for "F9" to be shown.
10. Rotate the temperature knob until "F9 H" is shown.
11. Press Restart.
12. Rotate the temperature knob until "F9 n" is shown.
13. Press Restart.
14. Rotate the temperature knob until the appropriate boiler output is shown (12 kW, 15 kW, 18 kW, 24 kW or 30 kW).
15. Press Restart.
16. The boiler type (H), gas type (n), output (12/15/18/24/30) and parameter set number will be shown in rotation. If this is OK press Restart to complete the configuration, otherwise switch mains power off to start again.
17. Check that the boiler operates.

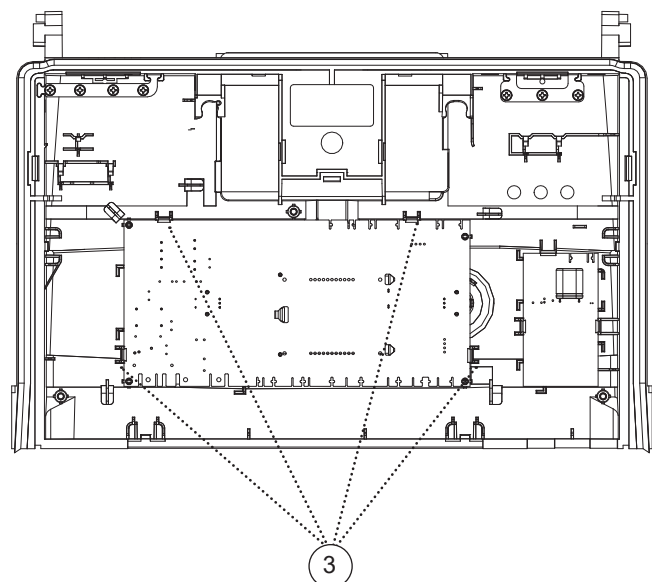
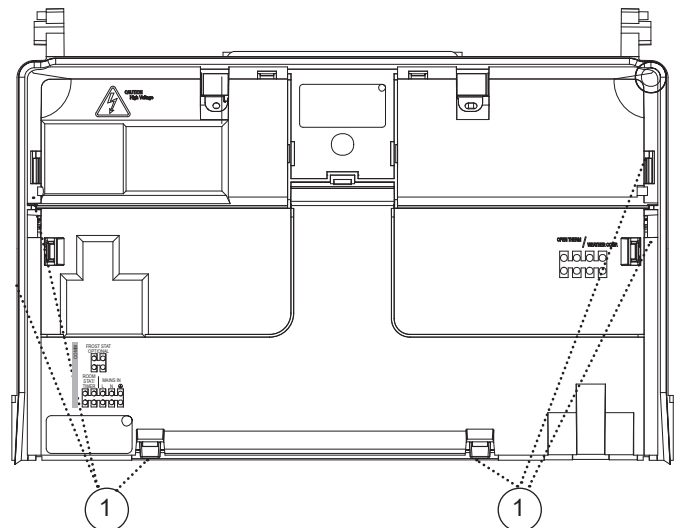



### 3.19 HEAT ENGINE REPLACEMENT

Refer to Section  
2.1

**CAUTION:** Protect the gas and electrical controls with a waterproof sheet.

Refer to Section  
3.2

1. Drain the boiler.

Refer to Section  
1.21

2. Undo the two screws and remove the sump cover retaining the lower flue manifold.
3. Lift the manifold to clear the bottom sealing gasket and remove manifold.
4. Remove the fan / venturi assembly and place on one side.

Refer to Section  
3.7

5. Remove the burner and place on one side.

Refer to Section  
3.7

6. Remove the ignition/detection electrode.

Refer to Section  
2.16

7. Remove the spark generator.

Refer to Section  
3.12

8. Remove the gas valve.

Refer to Section  
3.15

9. Remove the 2 M5 screws retaining the spark generator mounting bracket and transfer bracket to the new heat exchanger.
10. Remove the two retaining pipe clips and remove pipes.
11. Remove the condensate rubber pipe.

Refer to Section  
3.17 No.2

12. Remove the heat exchanger fixing screw.
13. Remove the Heat exchanger, slide out of location bracket.
14. If replacement sump required: Rotate heat exchanger assembly 180°. Place new sump onto heat exchanger, ensuring correct orientation and seal is in place.  
Then gently apply pressure to the base of the sump at each tab fixing point and engage tabs onto the heat exchanger.
15. Reassemble, ensuring the heat exchanger is located correctly in the RHS retaining bracket. Replace any new 'O' rings supplied with new heat exchanger and replace gaskets or seals if any sign of damage is evident. When replacing the spring clips located on the return pipe connection, ensure clip is oriented to correctly match connecting pipe diametres.

16. Ensure the trap is filled with water.

Refer to Section  
3.17

17. Refill the boiler and check for leaks.

Refer to Section  
2.22

18. Ensure all gas valve connections are gas tight with a gas soundness check up to the gas control valve.
19. Check that the boiler operates.

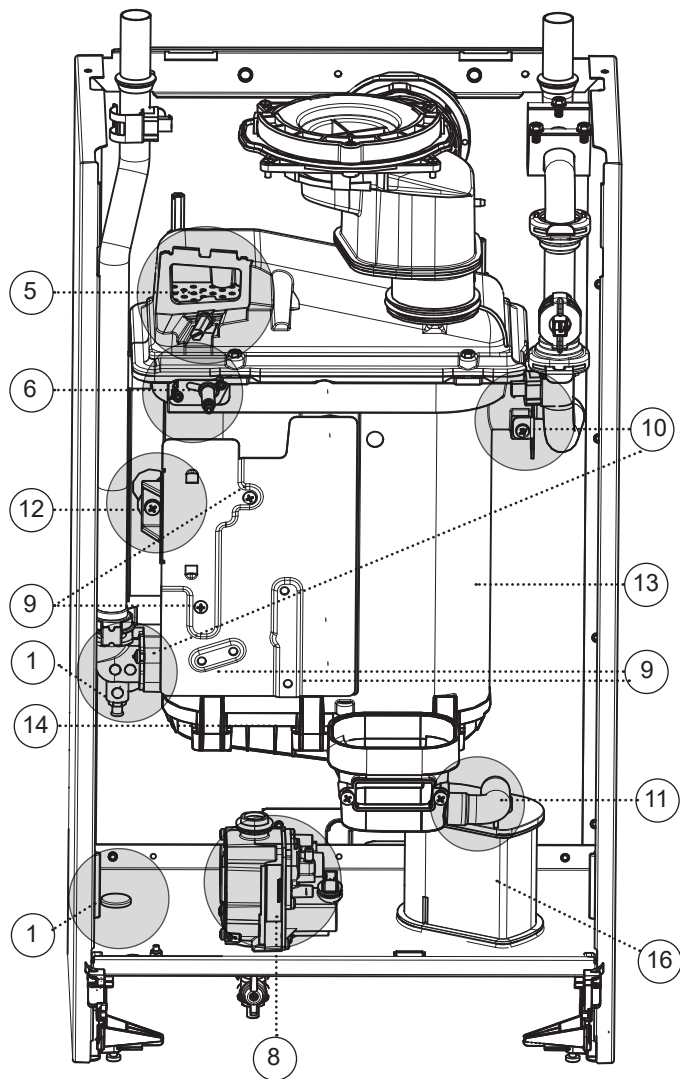



## Section 4 - Fault Finding

### 4.1 FAULT FINDING MAIN MENU

'L 01'	→	Go to Section 4.2: Flow Temperature Overheat Lockout
'L 02'	→	Go to Section 4.3: Ignition Lockout
'L 0C'	→	5 Restarts within 15 minutes: Turnpower off & on
'L 06'	→	Go to Section 4.4: False Flame Lockout
'F 02'	→	Go to Section 4.5: Flame Loss
'F 03'	→	Go to Section 4.6: Fan Fault
'L 0d'	→	Go to Section 4.3: Ignition Lockout: Blocked Flue/Condensate
'L 04' or 'F 04'	→	Go to Section 4.7: Flow Thermistor Fault
'L 05' or 'F 05'	→	Go to Section 4.9: Return Thermistor Fault
'F 06'	→	Go to Section 4.10: Outside Sensor Fault
'F 07'	→	Low Mains Voltage: Contact Electricity Provider
'F 09'	→	PCB Fault: Replace PCB
'F 0A'	→	Go to Section 4.8: Flow/Return Reversed
'F 0d'	→	Go to Section 4.15: No Water Flow
'F 0U'	→	Go to Section 4.14: Flow/Return Differential greater than 50°C
'F 0t'	→	Room Thermostat Fault: Check Room Stat & connections
'F 10'	→	Spark Generator Fault: Check wiring, if OK replace spark generator
No CH, but HW OK	→	Go to Section 4.11
No HW, but CH OK	→	Go to Section 4.13
No Display	→	Go to Section 4.12

## Section 4 - Fault Finding

### 4.2 'L 01' - OVERHEAT LOCKOUT

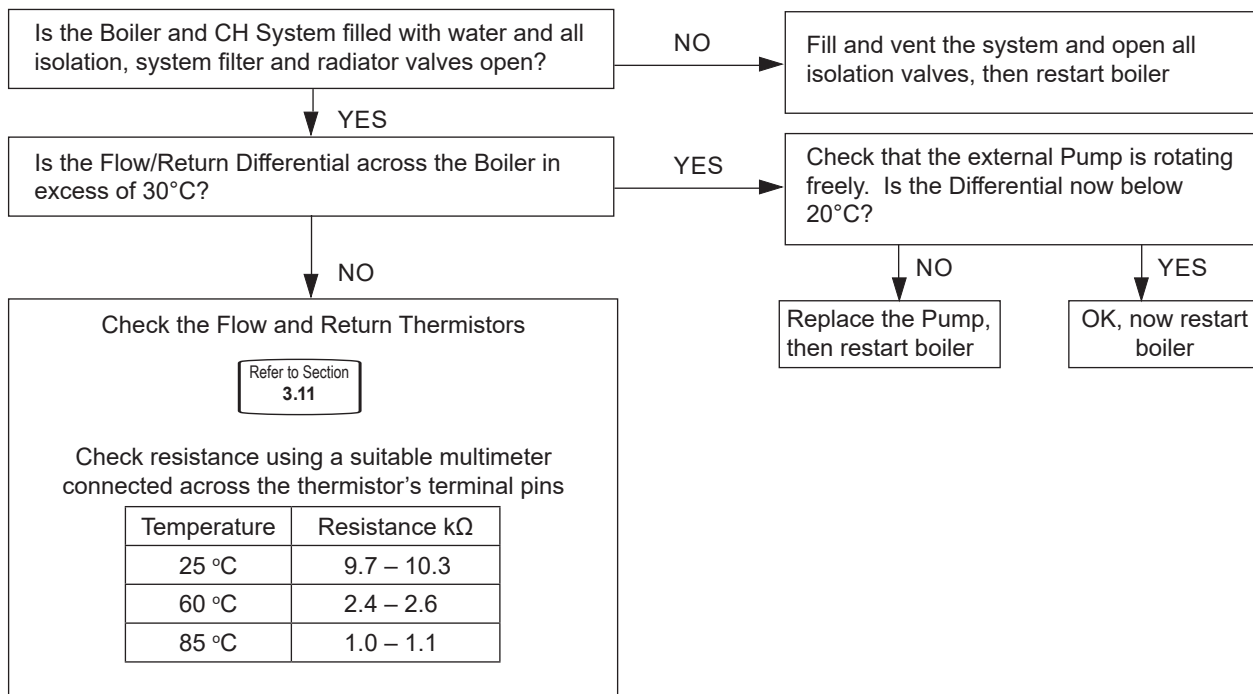

### 4.3 'L 02' - IGNITION LOCKOUT

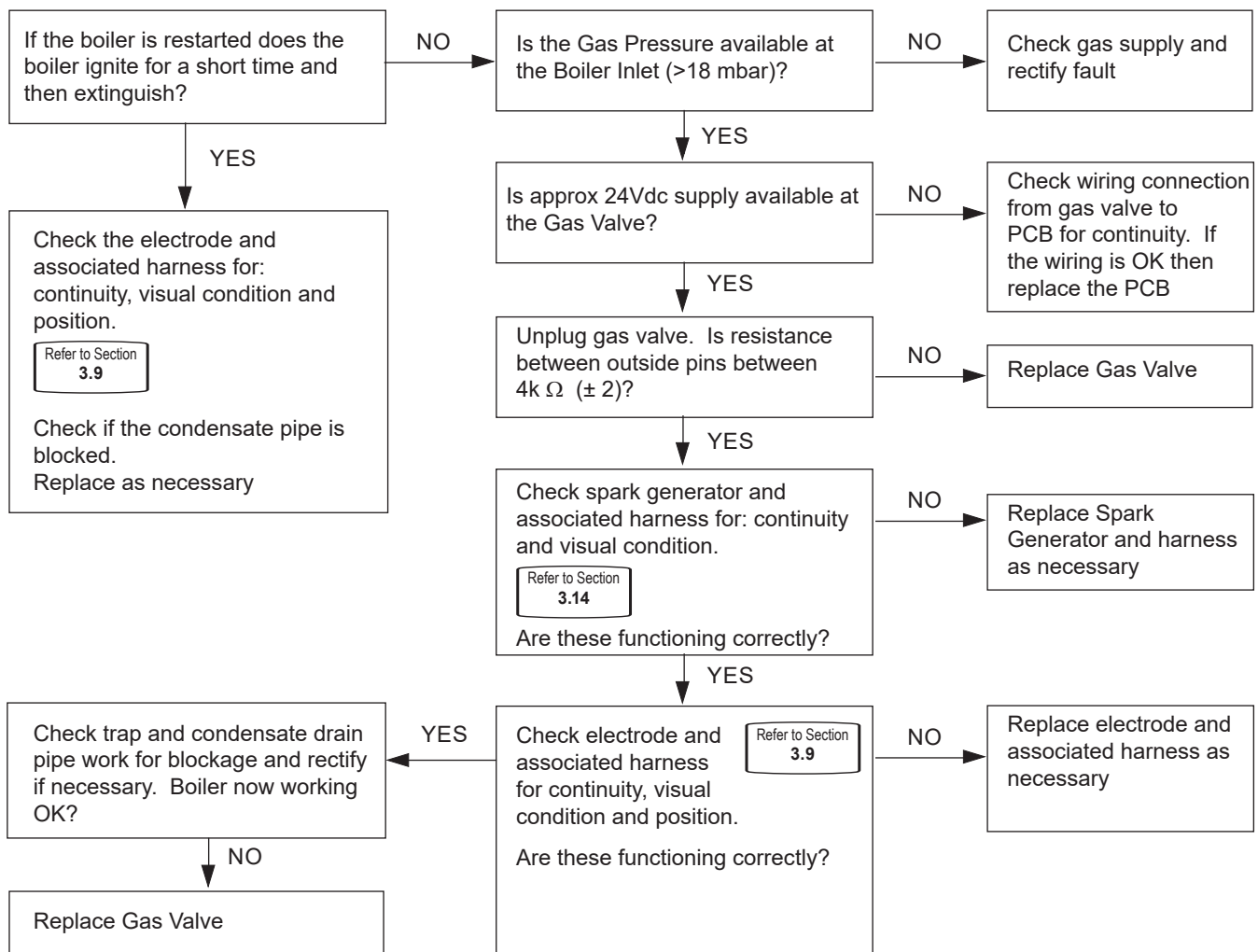

## Section 4 - Fault Finding

### 4.4 'L 06' - FLAME ON BEFORE GAS VALVE ON

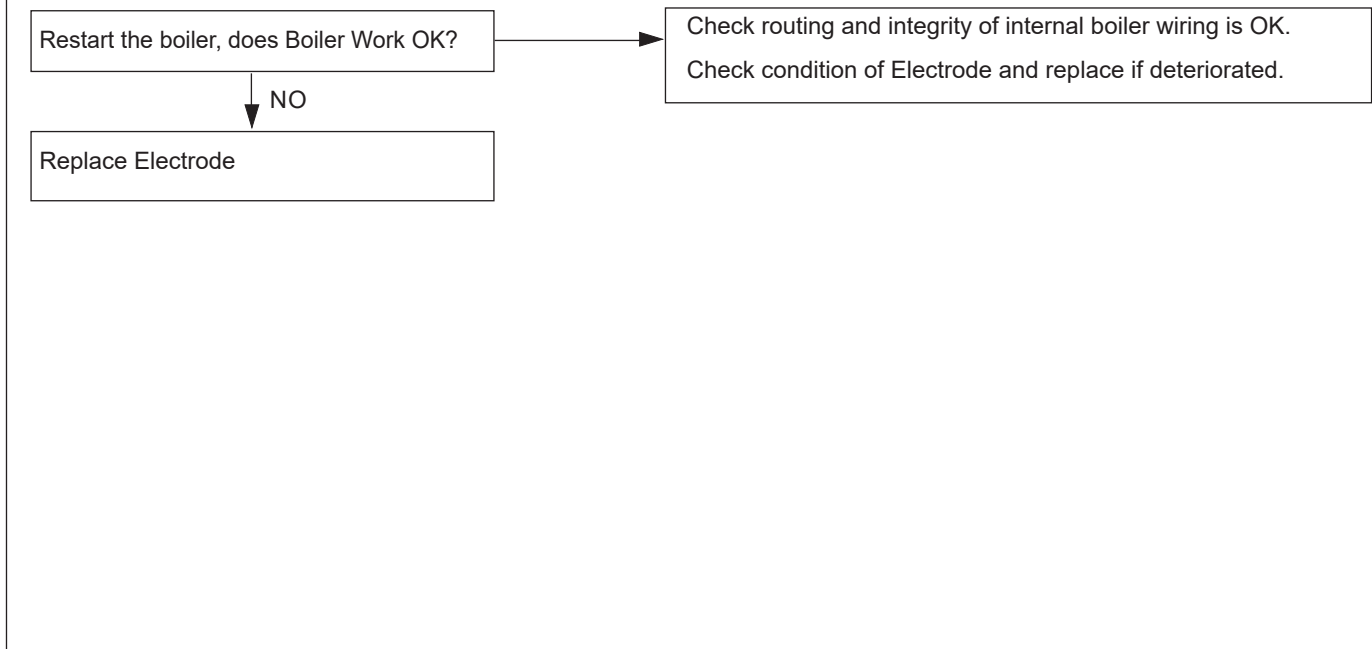

### 4.5 'F 02 OR FN OR LN' - FLAME LOSS

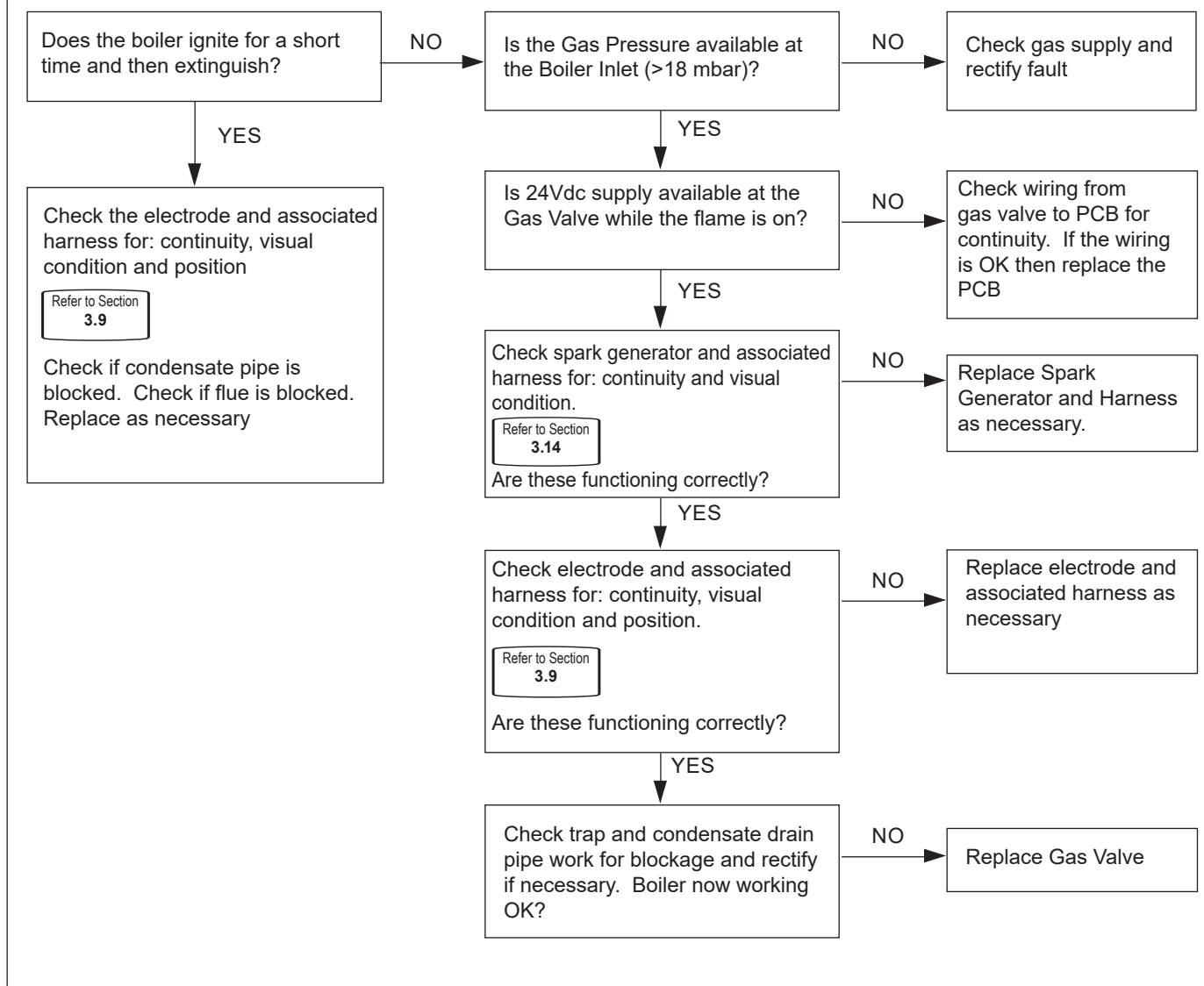

## Section 4 - Fault Finding

### 4.6 'F 03' - FAN FAULT

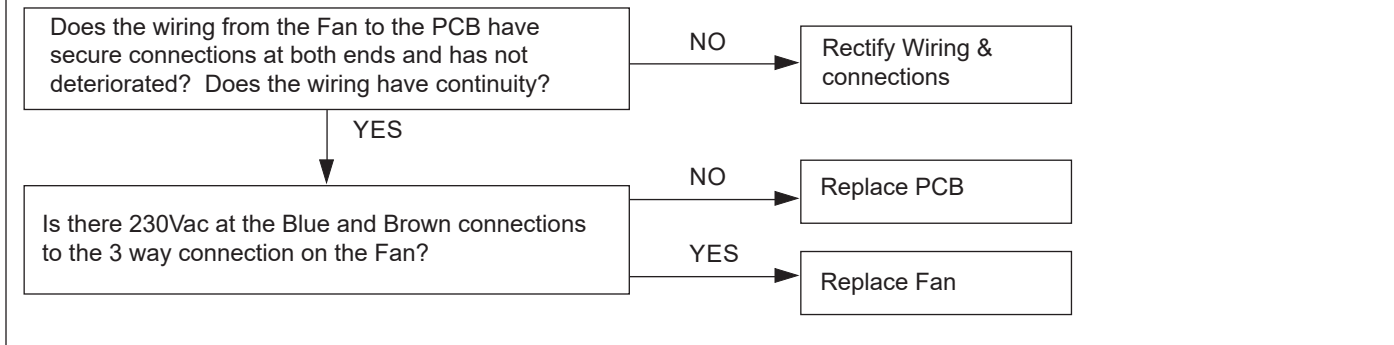

### 4.7 F 04 OR L 04' - FLOW THERMISTOR FAULT

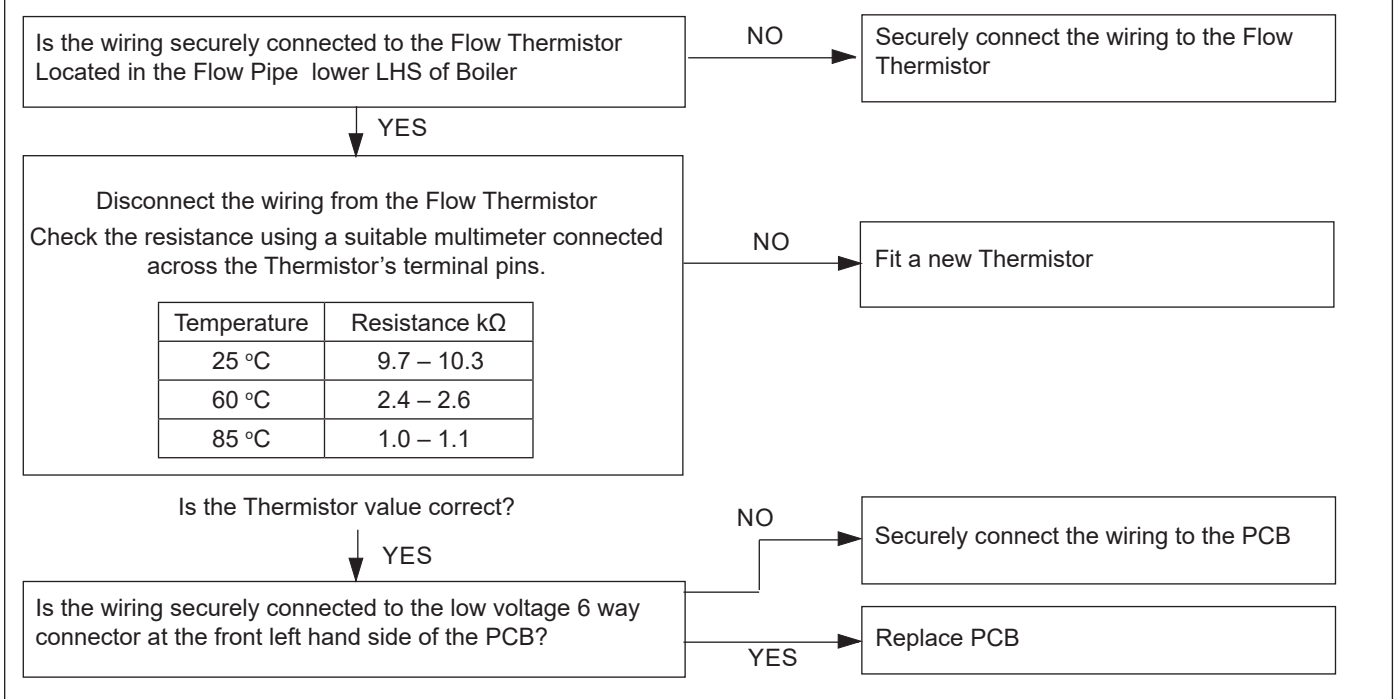

**FAULT FINDING**

### 4.8 FLOW / RETURN REVERSED

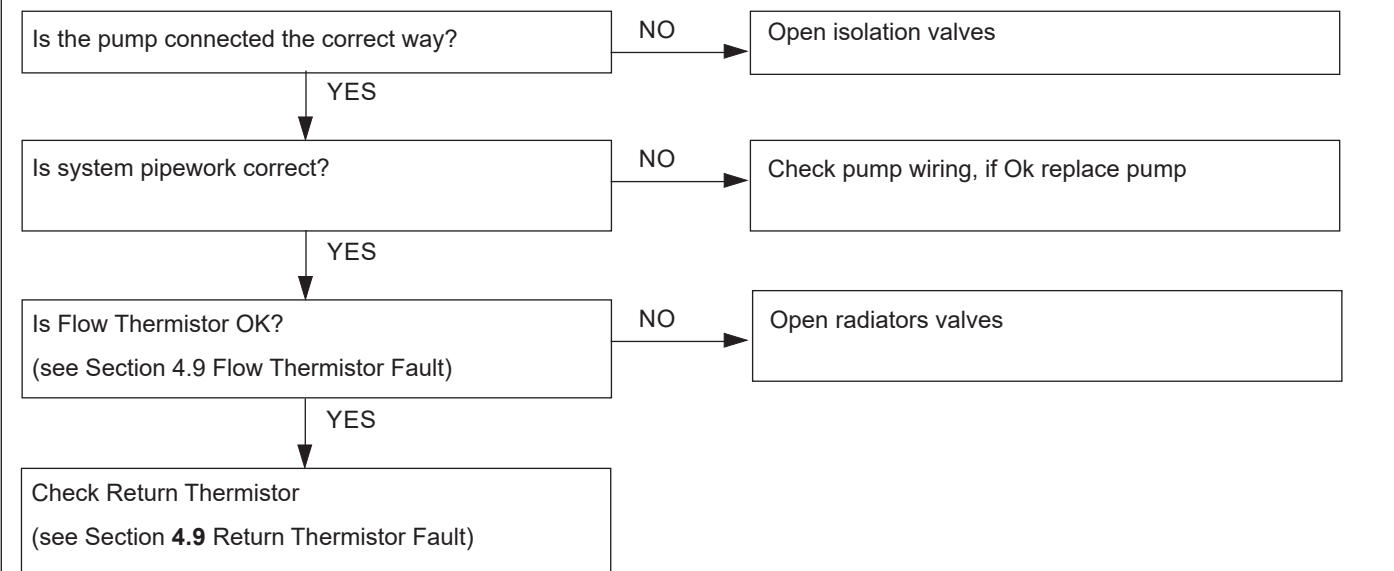

## Section 4 - Fault Finding

### 4.9 'F 05 OR L 05' - RETURN THERMISTOR FAULT

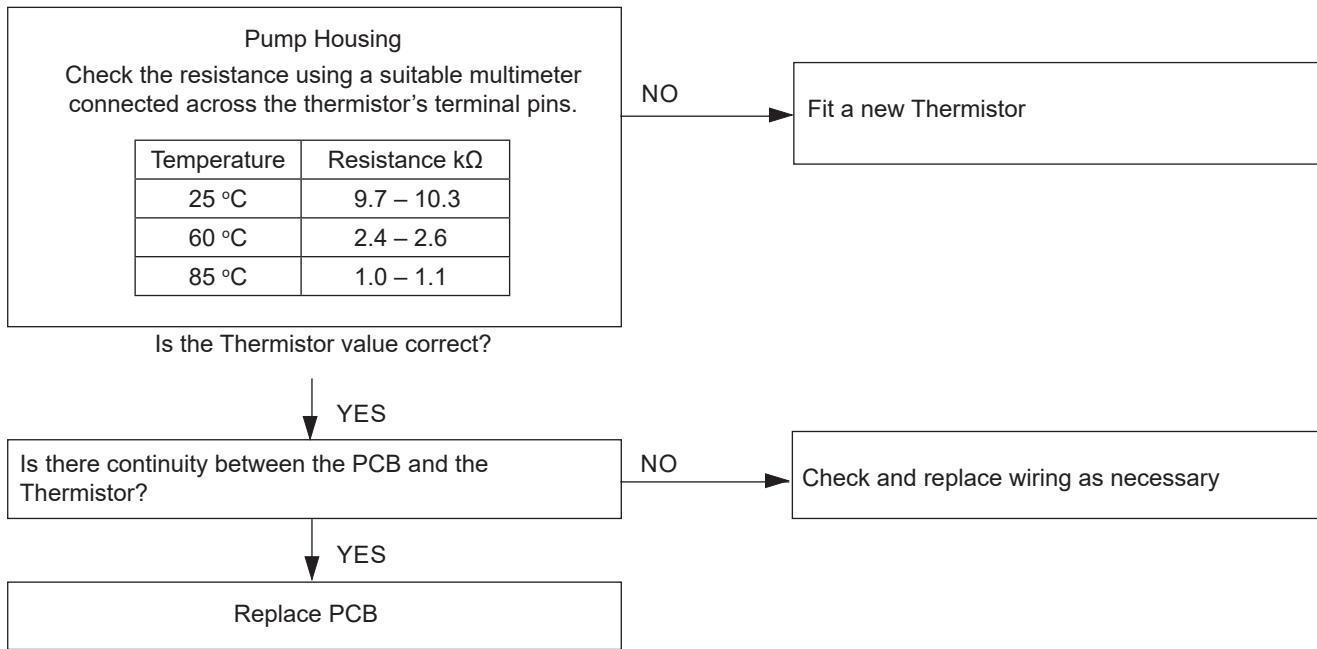

### 4.10 'F 06' - OUTSIDE SENSOR FAULT

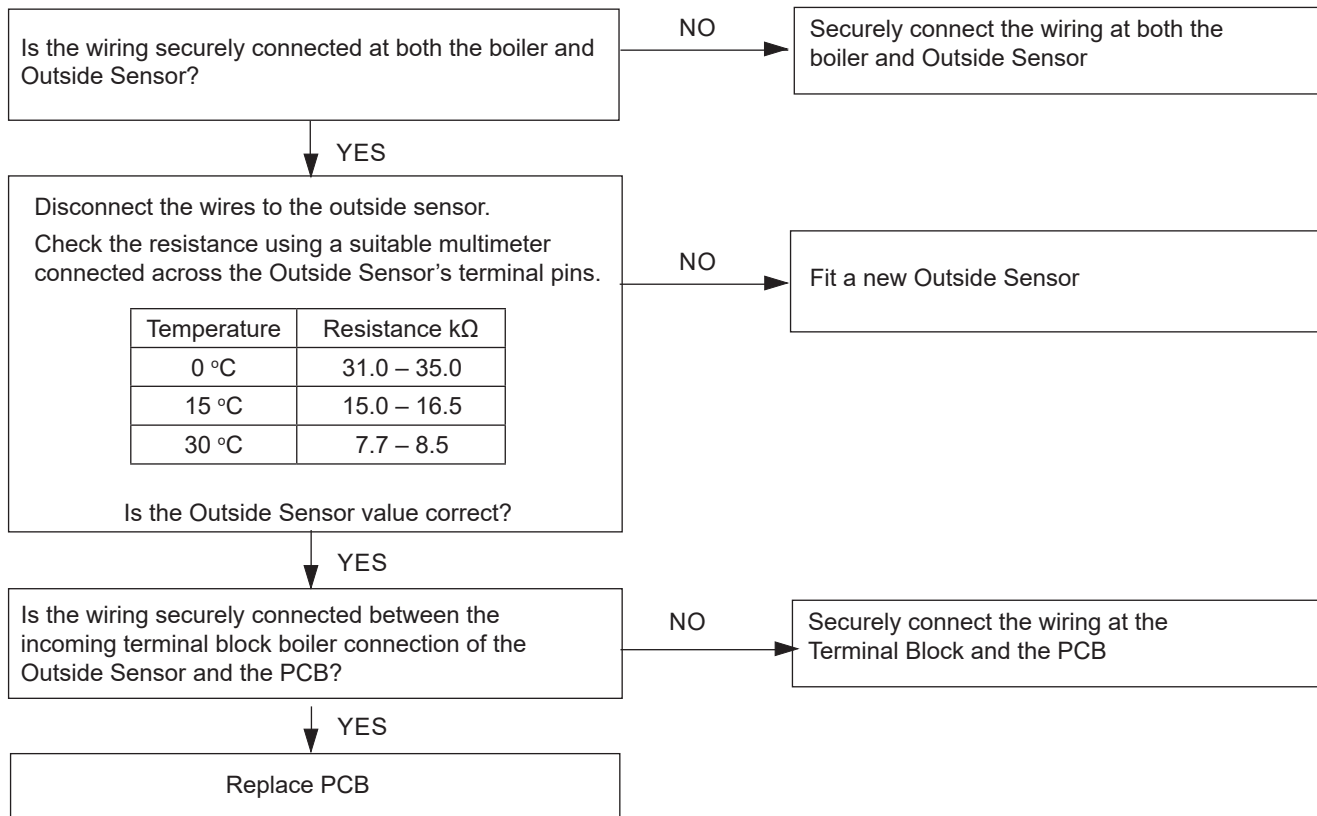

## Section 4 - Fault Finding

### 4.11 NO CH OPERATION

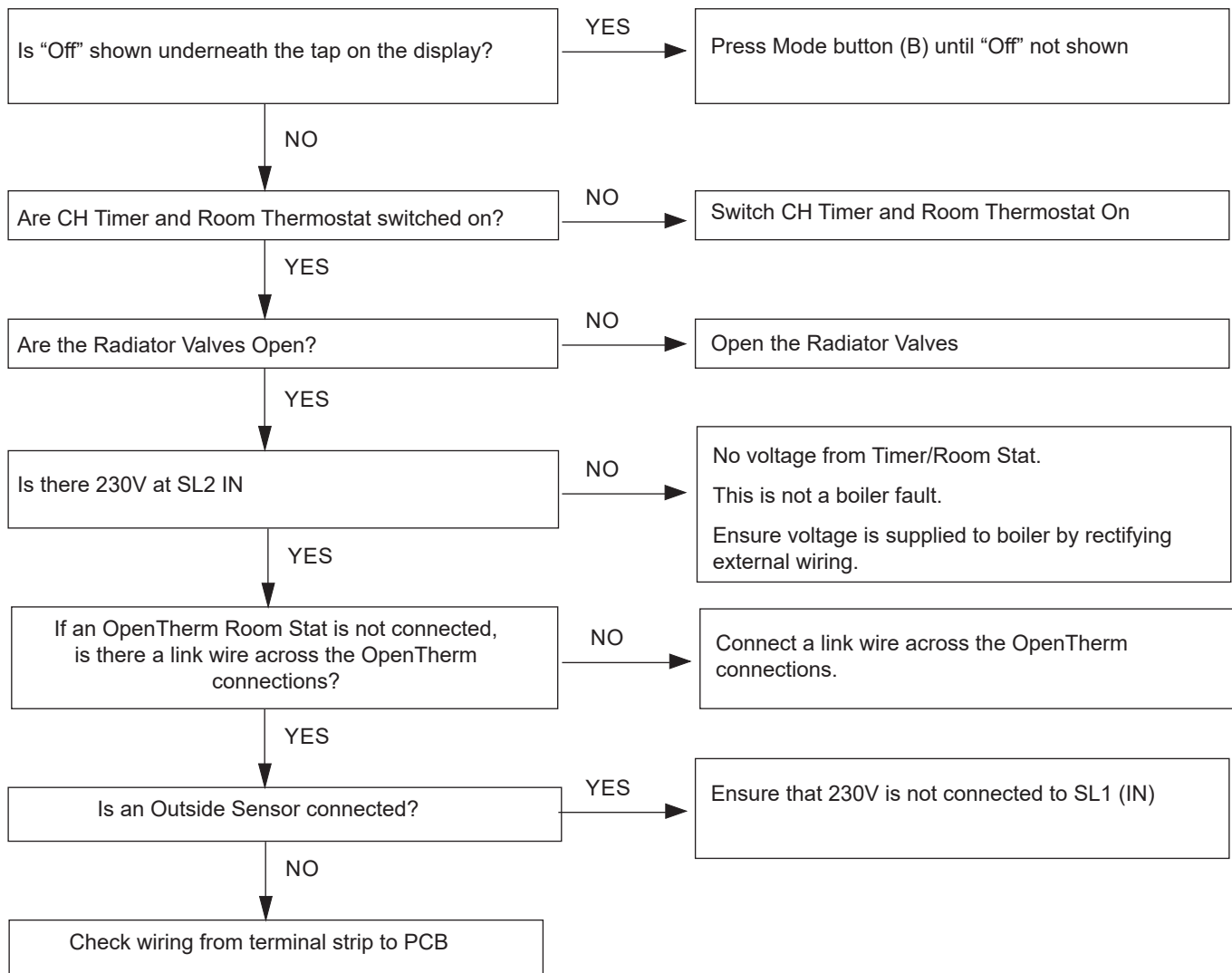

FAULT FINDING

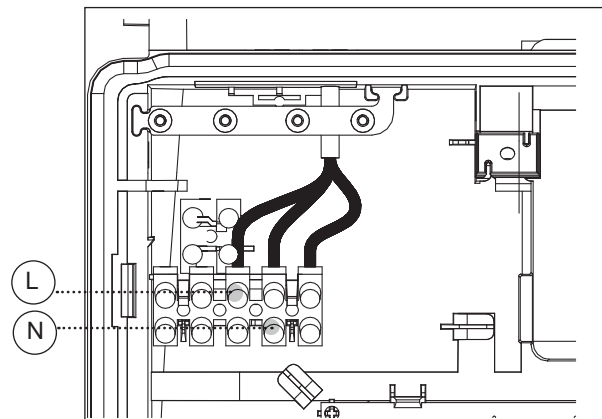
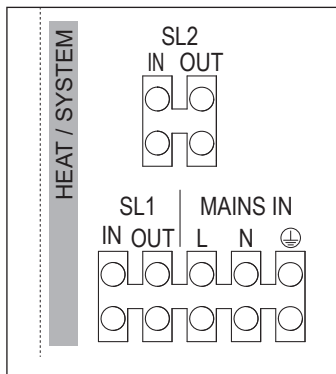

## Section 4 - Fault Finding

### 4.12 NO DISPLAY

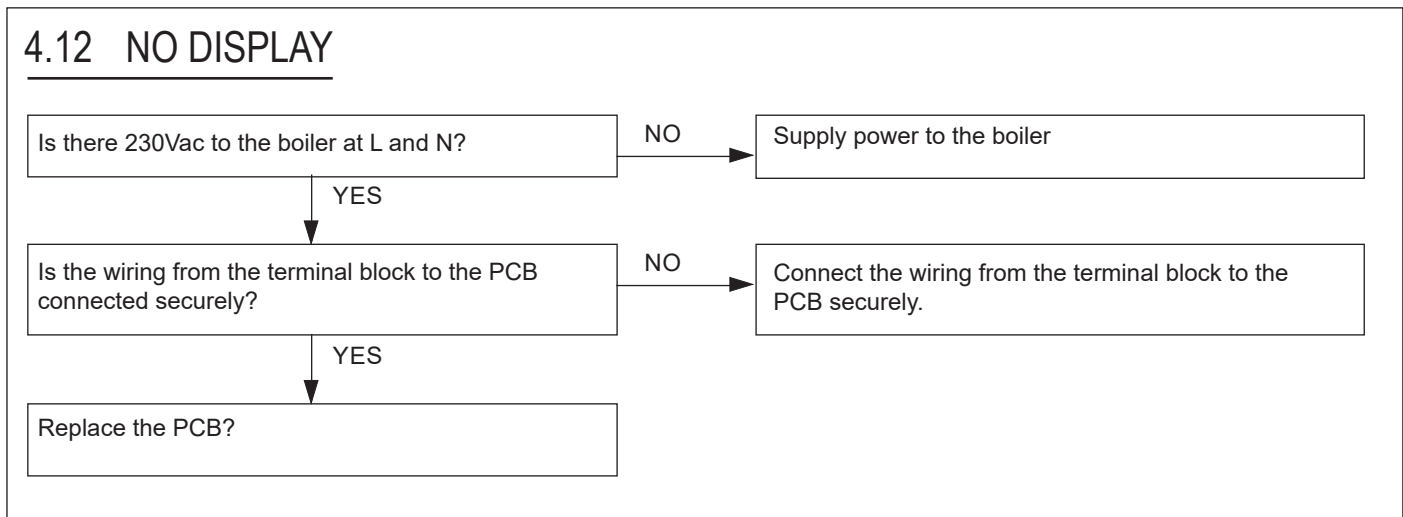

### 4.13 NO DHW OPERATION

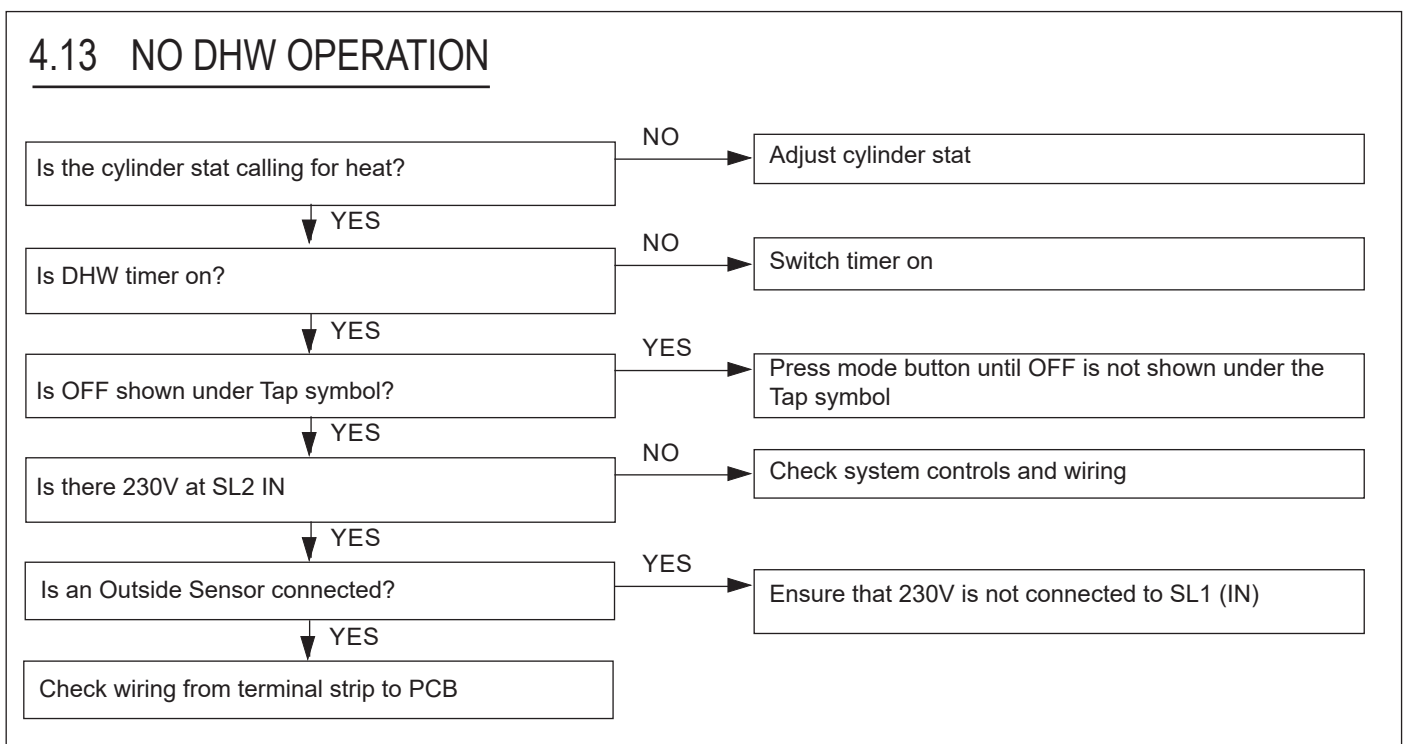

### 4.14 FLOW / RETURN DIFFERENTIAL GREATER THAN 50°C

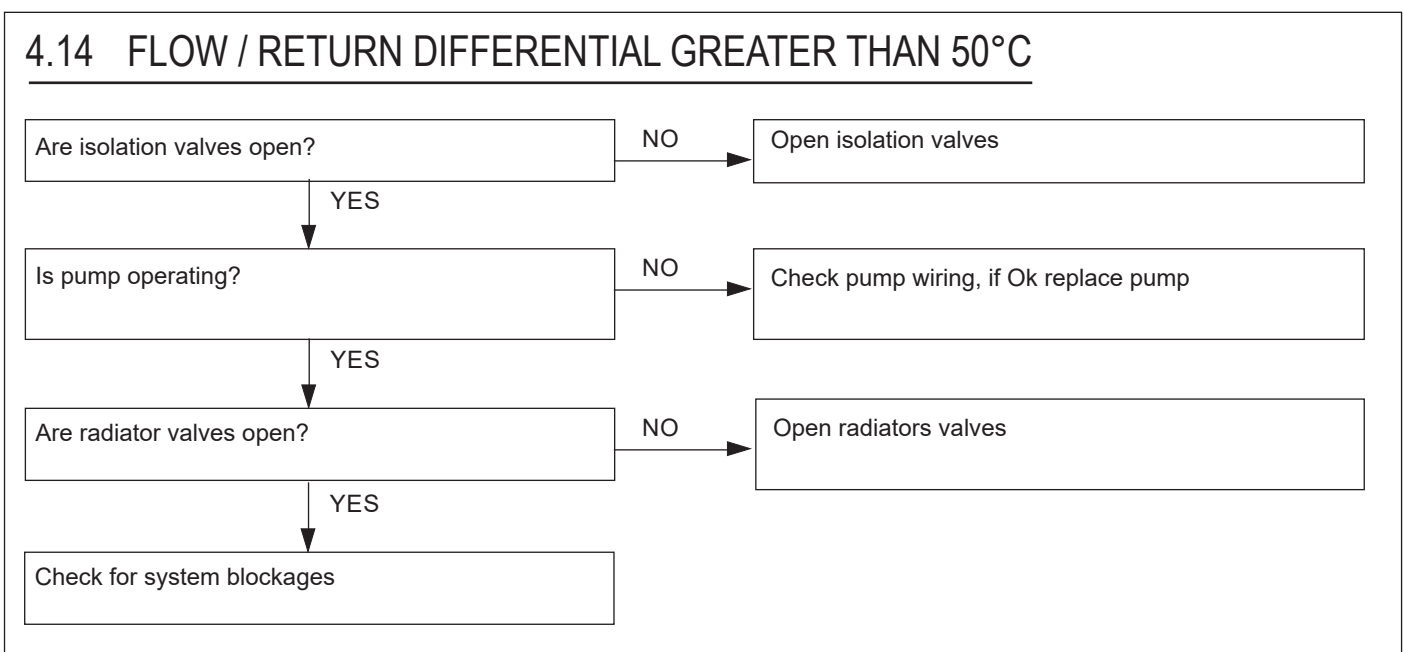



## Section 4 - Fault Finding

### 4.15 'F0 d' - NO WATER FLOW

**Note** - 'F0 d' will only be shown if no water flow is detected for 60 secs and the temperature is less than 40°C.

Are the boiler and CH system filled with water and all isolation and radiator valves open?

NO

Fill and vent the system and open all isolation valves.

YES

Turn power off and on, is the pump rotating?

NO

Check pump and check electrical connection to pump.

YES

Are connections to water flow sensor secure?

NO

Re-fit connector.

YES

Replace water flow sensor.

## Notes

## Section 5 - Spare Parts

When replacing any part on this appliance use only spare parts that you can be assured conform to the safety and performance specification that we require. Do not use reconditioned or copy parts that have not been clearly authorised by Ideal.

Failure to do so could affect safety or performance of this appliance.

Comprehensive spares parts information and details of approved Ideal Parts Distributors are available on **idealparts.com**

**LINK**  
to spares



**Our Parts team are also available to help with your Ideal Spare Parts enquiries on 01482 498665.**

When calling, and to ensure we can provide you with the most accurate parts information, please ensure you have the following to hand;

- Boiler Model
- Appliance GC Number
- Boiler Serial Number

# Code Of Practice

For the installation, commissioning and servicing of domestic heating and hot water products

Benchmark places responsibilities on both manufacturers and installers.\* The purpose is to ensure that customers\*\* are provided with the correct equipment for their needs, that it is installed, commissioned and serviced in accordance with the manufacturer's instructions by competent persons and that it meets the requirements of the appropriate Building Regulations. Installers are required to carry out work in accordance with the following:

### Standards of Work

- Be competent and qualified to undertake the work required.
- Install, commission, service and use products in accordance with the manufacturer's instructions provided.
- Ensure that where there is responsibility for design work, the installation is correctly sized and fit for purpose.
- Meet the requirements of the appropriate Building Regulations. Where this involves notifiable work be a member of a Competent Persons Scheme or confirm that the customer has notified Local Authority Building Control (LABC), prior to work commencing.
- Complete all relevant sections of the Benchmark Checklist/Service Record when carrying out commissioning or servicing of a product or system.
- Ensure that the product or system is left in a safe condition and, whenever possible, in good working order.
- Highlight to the customer any remedial or improvement work identified during the course of commissioning or servicing work.
- Refer to the manufacturer's helpline where assistance is needed.
- Report product faults and concerns to the manufacturer in a timely manner.

### Customer Service

- Show the customer any identity card that is relevant to the work being carried out prior to commencement or on request.
- Give a full and clear explanation/demonstration of the product or system and its operation to the customer.
- Hand over the manufacturer's instructions, including the Benchmark Checklist, to the customer on completion of an installation.
- Obtain the customer's signature, on the Benchmark Checklist, to confirm satisfactory demonstration and receipt of manufacturer's instructions.
- Advise the customer that regular product servicing is needed, in line with manufacturers' recommendations, to ensure that safety and efficiency is maintained.
- Respond promptly to calls from a customer following completion of work, providing advice and assistance by phone and, if necessary, visiting the customer.
- Rectify any installation problems at no cost to the customer during the installer's guarantee period.



\*The use of the word "installer" is not limited to installation itself and covers those carrying out installation, commissioning and/or servicing of heating and hot water products, or the use of supporting products (such as water treatment or test equipment).

\*\*Customer includes householders, landlords and tenants.

© Heating and Hotwater Industry Council (HHIC)

[www.centralheating.co.uk](http://www.centralheating.co.uk)

## Benchmark Commissioning & Warranty Validation Service Record

It is a requirement that the boiler is installed and commissioned to the manufacturers' instructions and the data fields on the commissioning checklist completed in full.

To instigate the boiler warranty the boiler needs to be registered with the manufacturer within one month of the installation. The warranty rests with the end-user (consumer), and they should be made aware it is ultimately their responsibility to register with the manufacturer, within the allotted time period.

It is essential that the boiler is serviced in line with the manufacturers' recommendations, at least annually. This must be carried out by a competent Gas Safe registered engineer. The service details should be recorded on the Benchmark Service and Interim Boiler Work Record and left with the householder. Failure to comply with the manufacturers' servicing instructions and requirements will invalidate the warranty.



[www.hhic.co.uk](http://www.hhic.co.uk)

**This Commissioning Checklist is to be completed in full by the competent person who commissioned the boiler as a means of demonstrating compliance with the appropriate Building Regulations and then handed to the customer to keep for future reference.**

Failure to install and commission according to the manufacturers' instructions and complete this Benchmark Commissioning Checklist will invalidate the warranty. This does not affect the customer's statutory rights.

\* All installations in England and Wales must be notified to Local Authority Building Control (LABC) either directly or through a Competent Persons Scheme. A Building Regulations Compliance Certificate will then be issued to the customer.

© Heating and Hotwater Industry Council (HHIC)



[www.centralheating.co.uk](http://www.centralheating.co.uk)

## Section 6 - Benchmark to Commissioning

### GAS BOILER SYSTEM COMMISSIONING CHECKLIST & WARRANTY VALIDATION RECORD

Address:													
Boiler make and model:													
Boiler serial number:													
Commissioned by (PRINT NAME):						Gas Safe registration number:							
Company name:						Telephone number:							
Company email:						Company address:							
										Commissioning date:			
Heating and hot water system complies with the appropriate Building Regulations?											Yes		
Optional: Building Regulations Notification Number (if applicable):													
Time, temperature control and boiler interlock provided for central heating and hot water											Yes		
Boiler Plus requirements (tick the appropriate box(s))													
Boiler Plus option chosen for combination boiler in ENGLAND						Weather compensation			Smart thermostat with automisation and optimisation				
						Load compensation			Flue Gas Heat Recovery				
Time and temperature control to hot water			Cylinder thermostat and programmer/timer						Combination boiler				
Zone valves			pre-existing			Fitted			Not required				
Thermostatic radiator valves			pre-existing			Fitted			Not required				
Automatic bypass to system			pre-existing			Fitted			Not required				
Underfloor heating			pre-existing			Fitted			Not required				
Water quality													
The system has been flushed, cleaned and a suitable inhibitor applied upon final fill, in accordance with BS7593 and boiler manufacturers' instructions											Yes		
What system cleaner was used?						Brand:			Product:				
What inhibitor was used?						Brand:			Product:				
Primary water system filter			pre-existing			Fitted			Not required				
CENTRAL HEATING MODE measure and record (as appropriate)													
Gas rate (for combination boilers complete DHW mode gas rate)						m <sup>3</sup> /hr			or			ft <sup>3</sup> /hr	
Central heating output left at factory settings?						Yes			No				
If no, what is the maximum central heating output selected?												kW	
Dynamic gas inlet pressure												mbar	
Central heating flow temperature												°C	
Central heating return temperature												°C	
System correctly balanced/rebalanced?						Yes							
COMBINATION BOILERS ONLY													
Is the installation in a hard water area (above 200ppm)?						Yes			No				
Water scale reducer/softener			pre-existing			Fitted			Not required				
What type of scale reducer/softener has been fitted?						Brand:			Product:				
Water meter fitted?						Yes			No				
If yes- DHW expansion vessel			pre-existing			Fitted			Not required				
Pressure reducing valve			pre-existing			Fitted			Not required				
DOMESTIC HOT WATER MODE Measure and record													
Gas rate						m <sup>3</sup> /hr			or			ft <sup>3</sup> /hr	
Dynamic gas inlet pressure at maximum rate												mbar	
Cold water inlet temperature												°C	
Hot water has been checked at all outlets						Yes			Temperature			°C	
CONDENSATE DISPOSAL													
The condensate drain has been installed in accordance with the manufacturers' instructions and/or BS5546/BS6798											Yes		
Point of termination						Internal			External (only where internal termination impractical)				
Method of disposal						Gravity			Pumped				
ALL INSTALLATIONS													
Record the following		At max rate:		CO ppm		CO <sub>2</sub> %		CO/CO <sub>2</sub>		Ratio			
		At min rate (where possible)		CO ppm		CO <sub>2</sub> %		CO/CO <sub>2</sub>		Ratio			
Where possible, has a flue integrity check been undertaken in accordance with manufacturers' instructions, and readings are correct?											Yes		
The operation of the boiler and system controls have been demonstrated to and understood by the customer											Yes		
The manufacturers' literature, including Benchmark Checklist and Service Record, has been explained and left with the customer											Yes		
Commissioning Engineer's signature													
Customer's signature (To confirm satisfactory demonstration and receipt of manufacturers' literature)													

\* All installations in England and Wales must be notified to Local Authority Building Control (LABC) either directly or through a Competent Persons Scheme. A Building Regulations Compliance Certificate will then be issued to the customer.

© Heating and Hotwater Industry Council (HHIC)



www.centralheating.co.uk

# Section 6 - Benchmark to Commissioning

## SERVICE & INTERIM BOILER WORK RECORD

It is recommended that your boiler and heating system are regularly serviced and maintained, in line with manufacturers' instructions, and that the appropriate service / interim work record is completed.

### Service provider

When completing a service record (as below), please ensure you have carried out the service as described in the manufacturers' instructions. Always use the manufacturers' specified spare parts.

SERVICE/INTERIM WORK ON BOILER <small>delete as appropriate</small>					Date:
Engineer name:		Company name:			
Telephone N°:		Gas Safe registration N°:			
Max rate	CO	ppm	CO <sub>2</sub>	%	CO/CO <sub>2</sub>
Min rate	CO	ppm	CO <sub>2</sub>	%	CO/CO <sub>2</sub>
Where possible, has a flue integrity check been undertaken in accordance with manufacturers' instructions, and readings are correct?*				yes	
Gas rate:	m <sup>3</sup> /h	OR	ft <sup>3</sup> /h		
Were parts fitted? <small>delete as appropriate</small>		Yes	No		
Parts fitted:					
System inhibitor concentration has been checked and appropriate action taken, in accordance with BS 7593 and boiler manufacturers' instructions. *				yes	n/a
Comments:					
Signature:					

\*A System inhibitor efficacy test is required on every annual service in accordance with the manufacturers' instructions and BS 7593. It is only acceptable to not have undertaken this if the service engineers attendance visit was in between annual services to attend a non-water facing component.

SERVICE/INTERIM WORK ON BOILER <small>delete as appropriate</small>					Date:
Engineer name:		Company name:			
Telephone N°:		Gas Safe registration N°:			
Max rate	CO	ppm	CO <sub>2</sub>	%	CO/CO <sub>2</sub>
Min rate	CO	ppm	CO <sub>2</sub>	%	CO/CO <sub>2</sub>
Where possible, has a flue integrity check been undertaken in accordance with manufacturers' instructions, and readings are correct?*				yes	
Gas rate:	m <sup>3</sup> /h	OR	ft <sup>3</sup> /h		
Were parts fitted? <small>delete as appropriate</small>		Yes	No		
Parts fitted:					
System inhibitor concentration has been checked and appropriate action taken, in accordance with BS 7593 and boiler manufacturers' instructions. *				yes	n/a
Comments:					
Signature:					

\*A System inhibitor efficacy test is required on every annual service in accordance with the manufacturers' instructions and BS 7593. It is only acceptable to not have undertaken this if the service engineers attendance visit was in between annual services to attend a non-water facing component.

SERVICE/INTERIM WORK ON BOILER <small>delete as appropriate</small>					Date:
Engineer name:		Company name:			
Telephone N°:		Gas Safe registration N°:			
Max rate	CO	ppm	CO <sub>2</sub>	%	CO/CO <sub>2</sub>
Min rate	CO	ppm	CO <sub>2</sub>	%	CO/CO <sub>2</sub>
Where possible, has a flue integrity check been undertaken in accordance with manufacturers' instructions, and readings are correct?*				yes	
Gas rate:	m <sup>3</sup> /h	OR	ft <sup>3</sup> /h		
Were parts fitted? <small>delete as appropriate</small>		Yes	No		
Parts fitted:					
System inhibitor concentration has been checked and appropriate action taken, in accordance with BS 7593 and boiler manufacturers' instructions. *				yes	n/a
Comments:					
Signature:					

\*A System inhibitor efficacy test is required on every annual service in accordance with the manufacturers' instructions and BS 7593. It is only acceptable to not have undertaken this if the service engineers attendance visit was in between annual services to attend a non-water facing component.

SERVICE/INTERIM WORK ON BOILER <small>delete as appropriate</small>					Date:
Engineer name:		Company name:			
Telephone N°:		Gas Safe registration N°:			
Max rate	CO	ppm	CO <sub>2</sub>	%	CO/CO <sub>2</sub>
Min rate	CO	ppm	CO <sub>2</sub>	%	CO/CO <sub>2</sub>
Where possible, has a flue integrity check been undertaken in accordance with manufacturers' instructions, and readings are correct?*				yes	
Gas rate:	m <sup>3</sup> /h	OR	ft <sup>3</sup> /h		
Were parts fitted? <small>delete as appropriate</small>		Yes	No		
Parts fitted:					
System inhibitor concentration has been checked and appropriate action taken, in accordance with BS 7593 and boiler manufacturers' instructions. *				yes	n/a
Comments:					
Signature:					

\*A System inhibitor efficacy test is required on every annual service in accordance with the manufacturers' instructions and BS 7593. It is only acceptable to not have undertaken this if the service engineers attendance visit was in between annual services to attend a non-water facing component.

SERVICE/INTERIM WORK ON BOILER <small>delete as appropriate</small>					Date:
Engineer name:		Company name:			
Telephone N°:		Gas Safe registration N°:			
Max rate	CO	ppm	CO <sub>2</sub>	%	CO/CO <sub>2</sub>
Min rate	CO	ppm	CO <sub>2</sub>	%	CO/CO <sub>2</sub>
Where possible, has a flue integrity check been undertaken in accordance with manufacturers' instructions, and readings are correct?*				yes	
Gas rate:	m <sup>3</sup> /h	OR	ft <sup>3</sup> /h		
Were parts fitted? <small>delete as appropriate</small>		Yes	No		
Parts fitted:					
System inhibitor concentration has been checked and appropriate action taken, in accordance with BS 7593 and boiler manufacturers' instructions. *				yes	n/a
Comments:					
Signature:					

\*A System inhibitor efficacy test is required on every annual service in accordance with the manufacturers' instructions and BS 7593. It is only acceptable to not have undertaken this if the service engineers attendance visit was in between annual services to attend a non-water facing component.

SERVICE/INTERIM WORK ON BOILER <small>delete as appropriate</small>					Date:
Engineer name:		Company name:			
Telephone N°:		Gas Safe registration N°:			
Max rate	CO	ppm	CO <sub>2</sub>	%	CO/CO <sub>2</sub>
Min rate	CO	ppm	CO <sub>2</sub>	%	CO/CO <sub>2</sub>
Where possible, has a flue integrity check been undertaken in accordance with manufacturers' instructions, and readings are correct?*				yes	
Gas rate:	m <sup>3</sup> /h	OR	ft <sup>3</sup> /h		
Were parts fitted? <small>delete as appropriate</small>		Yes	No		
Parts fitted:					
System inhibitor concentration has been checked and appropriate action taken, in accordance with BS 7593 and boiler manufacturers' instructions. *				yes	n/a
Comments:					
Signature:					

\*A System inhibitor efficacy test is required on every annual service in accordance with the manufacturers' instructions and BS 7593. It is only acceptable to not have undertaken this if the service engineers attendance visit was in between annual services to attend a non-water facing component.

\* All installations in England and Wales must be notified to Local Authority Building Control (LABC) either directly or through a Competent Persons Scheme. A Building Regulations Compliance Certificate will then be issued to the customer.

© Heating and Hotwater Industry Council (HHIC)



www.centralheating.co.uk



## Section 6 - Benchmark to Commissioning

### FLOWCHART FOR CO LEVEL AND COMBUSTION RATIO CHECK ON COMMISSIONING A CONDENSING BOILER

#### Important Preliminary Information on Checks

The air gas ratio valve is factory-set and must not be adjusted DURING COMMISSIONING.

If the boiler requires conversion to operate with a different gas family (e.g. conversion from natural gas to LPG) separate guidance is provided with the conversion kit supplied and this must be followed.

#### PRIOR TO CO LEVEL AND COMBUSTION RATIO CHECK

The installation instructions must have been followed, gas type verified and gas supply pressure / gas rate checked as required prior to commissioning.

As part of the installation process, ESPECIALLY WHERE A FLUE HAS BEEN FITTED BY PERSONS OTHER THAN THE BOILER INSTALLER, visually check the integrity of the whole flue system to confirm that all components are correctly assembled, fixed and supported. Check that maximum flue lengths have not been exceeded and all guidance has been followed (e.g. Gas Safe Register Technical Bulletin (TB) 008 where chimney/flues are in voids).

The ECGA should be of the correct type, as specified by BS EN 50379-3:2012.

Prior to its use, the ECGA should have been maintained and calibrated as specified by the manufacturer. The installer must have the relevant competence for use of the analyser.

Check and zero the analyser IN FRESH AIR in accordance with the analyser manufacturer's instructions.

KEY:

**CO** = carbon monoxide

**CO<sub>2</sub>** = carbon dioxide

**O<sub>2</sub>** = oxygen

**Combustion Ratio** = The CO reading measured in ppm divided by the CO<sub>2</sub> reading first converted to ppm

**ppm** = parts per million

**GS(I&U)R** = Gas Safety (Installation and Use) Regulations

**IMPORTANT.** Ensure boiler is in normal operation with a heat demand before setting Maximum / Minimum rate function.

#### Setting to Maximum Rate:

1. Hold "MODE" & "RESTART" buttons together for more than 5s
2. Last 3 faults will be shown
3. SH shown, press "RESTART" button
4. Burner will run for 10 minutes at maximum rate
5. Press "RESTART" to exit Maximum Rate mode

#### Setting to Minimum Rate:

1. Hold "MODE" & "RESTART" buttons together for more than 5s
2. Last 3 faults will be shown
3. SH shown, press "MODE" button
4. SL shown, press "RESTART"
5. If the Return Temperature is under 40°C then the burner will run at maximum rate for 30s before ramping down to minimum rate over 60s.
6. If the Return Temperature is over 40°C then the burner will ramp down to minimum rate over 60s.
7. Burner will run for 10 minutes at minimum rate
8. Press "RESTART" to exit Minimum Rate mode

## Section 6 - Benchmark to Commissioning

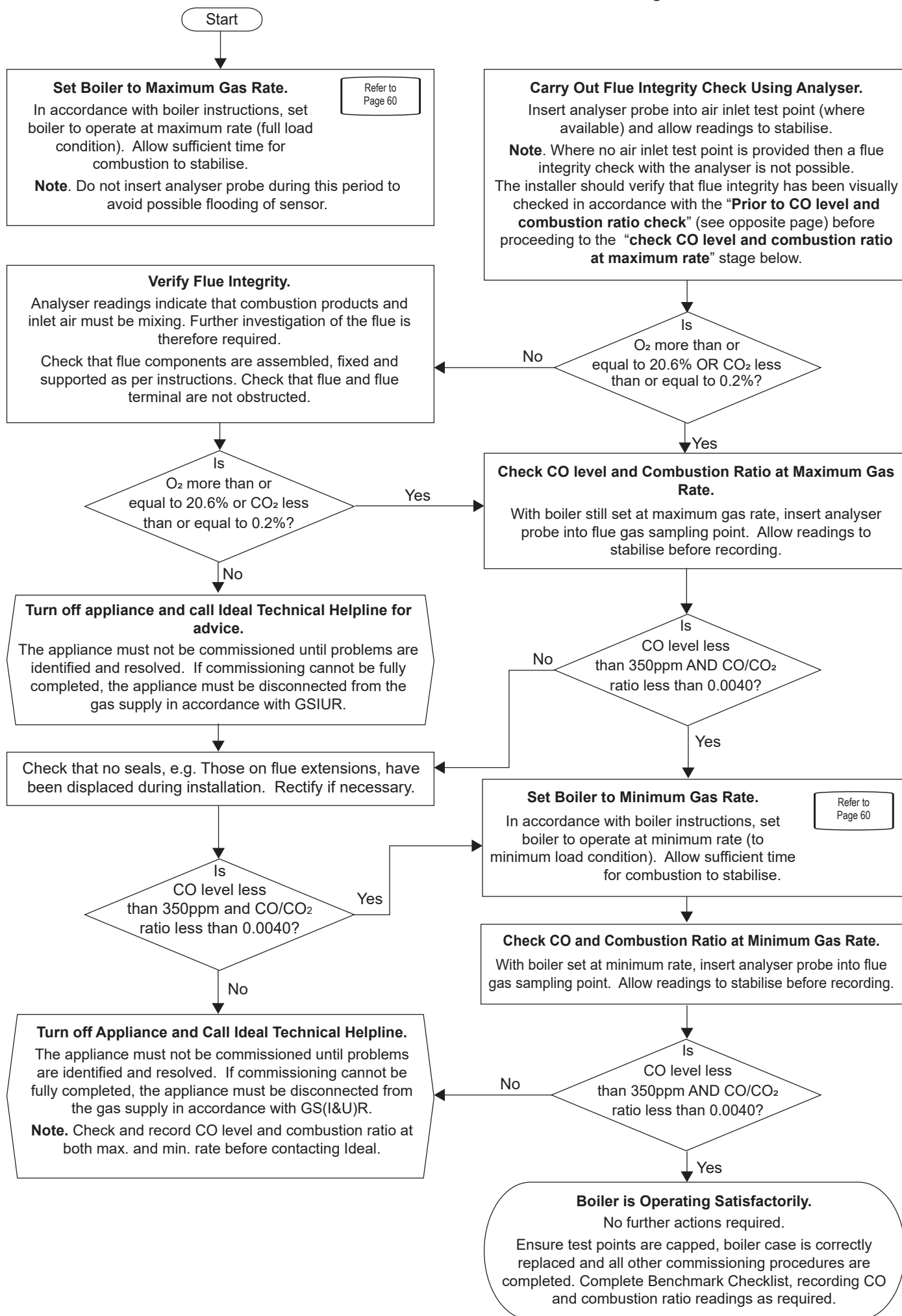

## Notes



At Ideal Heating we take our environmental impact seriously, therefore when installing any Ideal Heating product please make sure to dispose of any previous appliance in an environmentally conscious manner. Households can contact their local authority to find out how. See <https://www.gov.uk/managing-your-waste-an-overview> for guidance on how to efficiently recycle your business waste.

#### Technical Training

Our Expert Academy offer a range of training options designed and delivered by our experts in heating. For details please visit: [expert-academy.co.uk](http://expert-academy.co.uk)

Ideal Boilers Ltd., pursues a policy of continuing improvement in the design and performance of its products. The right is therefore reserved to vary specification without notice.

Ideal is a trademark of Ideal Boilers.

Registered Office

Ideal Boilers Ltd., National Avenue, Hull, East Yorkshire, HU5 4JB

Tel 01482 492251 Fax 01482 448858

Registration No. London 322 137

EU Authorised Representative:

Atlantic SFDT

44 Boulevard des Etats-Unis, 85 000 La Roche-Sur-Yon, France

+33 (0)2 51 44 34 34

Ideal Technical Helpline: 01482 498663

Ideal Consumer Helpline: 01482 498660

Ideal Parts: 01482 498665

[idealheating.com](http://idealheating.com)

**ideal**  
HEATING



# USER GUIDE

**LOGIC HEAT<sup>2</sup>  
H12 H15 H18 H24 H30**

When replacing any part on this appliance, use only spare parts that you can be assured conform to the safety and performance specification that we require. Do not use reconditioned or copy parts that have not been clearly authorised by Ideal Heating.

For the very latest copy of literature for specification and maintenance practices visit our website [idealheating.com](http://idealheating.com) where you can download the relevant information in PDF format.

# CONTENTS

1.1 Introduction .....	3	1.5 Points for the boiler user.....	5
1.2 Boiler Operation.....	3-4	1.6 Troubleshooting.....	5
1.3 Frozen Condensate Drain .....	4	1.7 Normal Operation Display Codes .....	6
1.4 General Information.....	5	1.8 Fault Codes .....	7



**WEEE DIRECTIVE 2012/19/EU**  
**Waste Electrical and Electronic Equipment Directive**

- At the end of the product life, dispose of the packaging and product in a corresponding recycle centre.
- Do not dispose of the unit with the usual domestic refuse.
- Do not burn the product.
- Remove the batteries.
- Dispose of the batteries according to the local statutory requirements and not with the usual domestic refuse.



All Gas Safe Register installers carry a Gas Safe Register ID card, and have a registration number. Both should be recorded in the Benchmark Commissioning Checklist. You can check your installer by calling Gas Safe Register direct on 0800 4085500.

**Ideal Heating** is a member of the Benchmark scheme and fully supports the aims of the programme. Benchmark has been introduced to improve the standards of installation and commissioning of central heating systems in the UK and to encourage the regular servicing of all central heating systems to ensure safety and efficiency.



THE BENCHMARK SERVICE INTERVAL RECORD MUST BE COMPLETED AFTER EACH SERVICE

## 1.1 INTRODUCTION

The Logic Heat<sup>2</sup> H is a heat only boiler, featuring full sequence automatic spark ignition and fan assisted combustion. It is designed to provide central heating and hot water when a separate hot water cylinder is installed.

Due to the high efficiency of the boiler, condensate is produced from the flue gases and this is drained to a suitable disposal point through a plastic waste pipe at the base of the boiler. A condensate 'plume' will also be visible at the flue terminal.

### Safety

#### CURRENT GAS SAFETY (INSTALLATION & USE) REGULATIONS OR RULES IN FORCE.

It is the law that this appliance installation and any work carried out on the appliance is carried out by a Gas Safe Registered engineer in accordance with the above Regulations.

It is essential that the instructions in this booklet are strictly followed, for safe and economical operation of the boiler.

#### ELECTRICITY SUPPLY

**This appliance must be earthed.**

**Supply: 230 V ~ 50 Hz. The fusing should be 3A.**

#### IMPORTANT NOTES

- This appliance must not be operated without the casing correctly fitted and forming an adequate seal.
- If the boiler is installed in a compartment then the compartment **MUST NOT** be used for storage purposes.

- If it is known or suspected that a fault exists on the boiler then it **MUST NOT BE USED** until the fault has been corrected by a Gas Safe Registered Engineer.
- Under **NO** circumstances should any of the sealed components on this appliance be used incorrectly or tampered with.
- **This appliance can be used by children 8 years and above. Also persons with reduced physical, sensory or mental capabilities, or lack of experience and knowledge, provided they have been given supervision or instruction concerning use of the appliance in a safe way and understand the hazards involved. Children shall not play with the appliance. Cleaning and user maintenance shall not be made by children without supervision.**

#### CARBON MONOXIDE ALARMS

Carbon monoxide detectors are installed near to the boiler to detect a gas leak. If a leak is detected the alarm will make a very loud noise. If you suspect that there is a fault with the alarm, you should first change the batteries.

If you change the batteries and the fault does not clear, you must speak to your landlord or replace the device with another that complies to BS EN 50291-1:2010.

## 1.2 BOILER OPERATION

### Legend

- A. Temperature Knob
- B. Mode Button
- C. Boiler Status Display
- D. Burner On indicator
- E. Restart Button

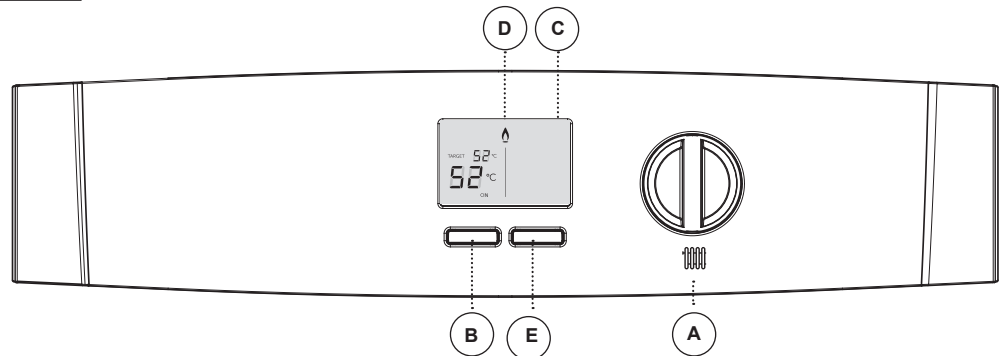

If an L code is shown on the display then the boiler can be restarted by pressing the Restart button (E).

### To START the boiler

- 1 Switch on electricity to the boiler and check that all external controls e.g. programmer, room thermostat and cylinder thermostat are all on.
2. If OFF is shown at the bottom of the screen press the Mode button so that ON appears.
3. Turn the Temperature control knob until 80°C is shown.

Once the boiler has lit see the following page about where the Temperature control knob should be set.

**Note.** In normal operation the boiler status display (C) will display messages.

Refer to Section  
1.7

Boiler frost protection – boiler will fire if temperature is below 5°C.

During normal operation the burner symbol '🔥' will remain illuminated when the burner is lit.

If the boiler fails to light after five attempts the following fault messages will be displayed:

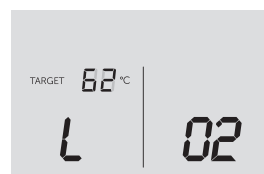

To restart the boiler, press Restart. The boiler will repeat the ignition sequence. If the boiler still fails to light consult a Registered Gas Installer.

## OPERATION MODES

**Winter/Summer Conditions** – (Domestic Hot Water required, Central Heating may be required)

If OFF is shown at the bottom of the screen then press the Mode button so that ON appears.

The boiler will fire and supply heat to the hot water cylinder and radiators.

**Boiler Off** – (neither Domestic Hot Water or Central Heating required)

If ON is shown at the bottom of the screen then press the Mode button so that OFF appears.

## CONTROL OF WATER TEMPERATURE

### 1. No Outside Sensor Connected

If no outside sensor is connected then the temperature of the water leaving the boiler to go to either the radiators or the hot water cylinder can be set anywhere between 80°C and 30°C by rotating the Temperature Control Knob (B) clockwise or anti-clockwise.

### 2. Outside Sensor Connected

If an outside sensor is connected then the temperature of the water going to the hot water cylinder is factory set to 80°C (but the temperature of the hot water to the tap is set by the thermostat on the hot water cylinder).

The nominal central heating room temperature can be set anywhere between 30°C and 10°C by rotating the Temperature control knob (B) clockwise or anti-clockwise (if you are too cold rotate the knob clockwise, if you would like to run your central heating more efficiently rotate the knob anti-clockwise).

For economy setting refer to Efficient Heating System Operation.

## EFFICIENT HEATING SYSTEM OPERATION

The boiler is a high efficiency, condensing appliance which will automatically adjust its output to match the demand for heat. Therefore gas consumption is reduced as the heat demand is reduced.

The boiler condenses water from the flue gases when operating most efficiently. To operate your boiler efficiently (using less gas) turn the central heating temperature knob (B) lower. In winter periods it may be necessary to turn the knob towards a higher temperature position to meet heating requirements. This will depend on the house and radiators used.

Reducing the room thermostat setting by 1°C can reduce gas consumption by up to 10%.

## BOILER FROST PROTECTION

The boiler is fitted with frost protection that operates in all modes, provided the power supply to the boiler is always turned on. If the water in the boiler falls below 5°C, the frost protection will activate and run the boiler to avoid freezing. The process does not guarantee that all other parts of the system will be protected.

If a system frost thermostat has been installed, the boiler must be set in winter mode, "(there should not be a cross through the radiator symbol)", for the system frost protection to run.

If no system frost protection is provided and frost is likely during a short absence from home it is recommended to leave the system heating controls or built in programmer (if fitted) switched on and run at a reduced temperature setting.

For longer periods, the entire system should be drained.

## MAINS POWER OFF

To remove all power to the boiler the mains power switch must be turned off.

## 1.3 FROZEN CONDENSATE DRAIN

This appliance is fitted with a siphonic condensate trap system that reduces the risk of the appliance condensate from freezing. However should the condensate pipe to this appliance freeze, please follow these instructions:

- a. If you do not feel competent to carry out the defrosting instructions below please call your local Gas Safe Registered installer for assistance.
- b. If you do feel competent to carry out the following instructions please do so with care when handling hot utensils. Do not attempt to thaw pipework above ground level.

If this appliance develops a blockage in its condensate pipe, its condensate will build up to a point where it will make a gurgling noise prior to locking out, showing an  $L0d$  or " $L2$ " fault code.

If the appliance is restarted it will make a gurgling noise prior to locking out, showing an  $L02$  fault code.

### To unblock a frozen condensate pipe;

1. Follow the routing of the plastic pipe from its exit point on the appliance, through its route to its termination point. Locate the frozen blockage. It is likely that the pipe is frozen at the most exposed point external to the building or where there is some obstruction to flow. This could be at the open end of the pipe, at a bend or elbow, or where there is a dip in the pipe in which condensate can collect. The location of the blockage should be identified as closely as possible before taking further action.
2. Apply a hot water bottle, microwaveable heat pack or a warm damp cloth to the frozen blockage area. Several applications may have to be made before it fully defrosts. Warm water can also be poured onto the pipe from a watering can or similar. DO NOT use boiling water.
3. Caution when using warm water as this may freeze and cause other localised hazards.
4. Once the blockage is removed and the condensate can flow freely, restart the appliance. (Refer to "To Start the boiler")
5. If the appliance fails to ignite, call your Gas Safe Registered engineer.

### Preventative solutions

During cold weather, set the central heating temperature knob (B) to maximum (must return to original setting once cold spell is over).

Place the heating on continuous and turn the room thermostat down to 15°C overnight or when unoccupied.

(Return to normal after cold spell).

SCAN  
for video





## 1.4 GENERAL INFORMATION

### BOILER PUMP

The boiler pump will operate briefly as a self-check once every 24 hours, regardless of system demand.

### MINIMUM CLEARANCES

Clearance of 165mm above, 100mm below, 2.5mm at the sides and 450mm at the front of the boiler casing must be allowed for servicing.

#### Bottom Clearance

Bottom clearance after installation can be reduced to 5mm.

This must be obtained with an easily removable panel, to enable the system pressure gauge to be visible and to provide the 100mm clearance required for servicing.

### ESCAPE OF GAS

Should a gas leak or fault be suspected contact the National Gas Emergency Service without delay.

Telephone 0800 111 999.

#### Ensure that;

- All naked flames are extinguished
- Do not operate electrical switches
- Open all windows and doors

### CLEANING

For normal cleaning simply dust with a dry cloth. To remove stubborn marks and stains, wipe with a damp cloth and finish off with a dry cloth. **DO NOT use abrasive cleaning materials.**

### MAINTENANCE

The frequency of servicing will depend upon the installation condition and usage but should be carried out at least annually by a Gas Safe Registered Engineer.

## 1.5 POINTS FOR THE BOILER USER

**Note.** In line with our current warranty policy we would ask that you check through the following guide to identify any problems external to the boiler prior to requesting a service engineers visit. Should the problem be found to be other than with the appliance we reserve the right to levy a charge for the visit, or for any pre-arranged visit where access is not gained by the engineer.

**FOR ANY QUERIES PLEASE RING THE IDEAL  
CONSUMER HELPLINE : 01482 498660**

**BOILER RESTART PROCEDURE - To restart boiler  
press the restart button**

## 1.6 TROUBLESHOOTING

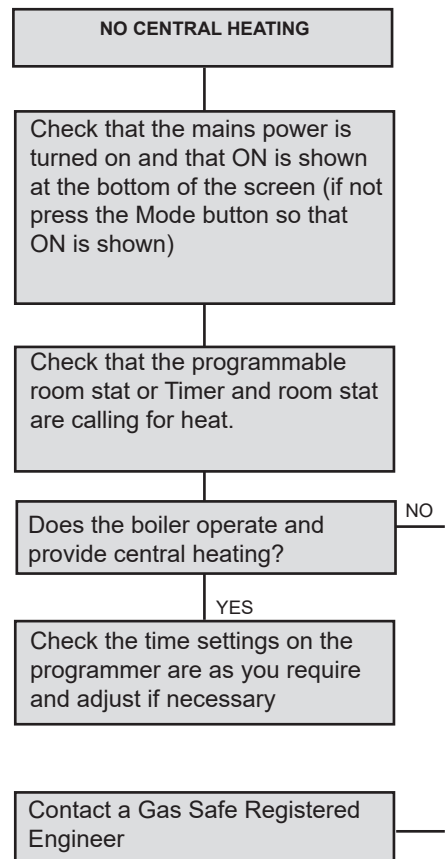
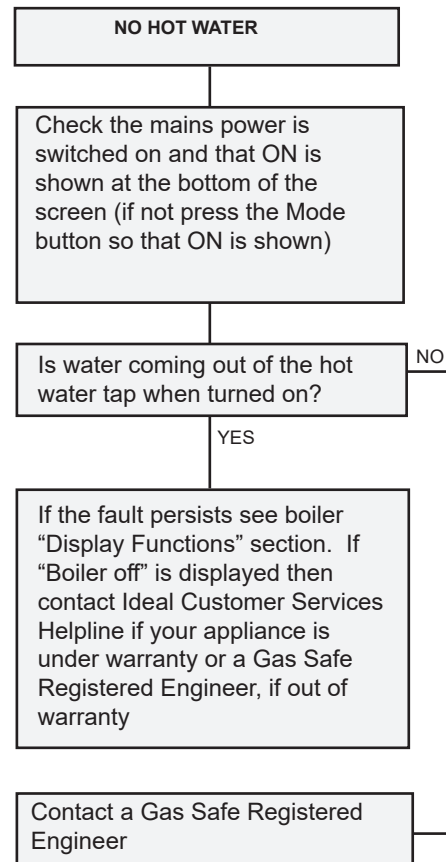

## 1.7 NORMAL OPERATION DISPLAY CODES

The user control has one display to inform the user about the status of the boiler. The display shows the status of the flame. If no flame is detected then flame symbol will not be visible. When the flame is detected the flame symbol will be visible permanently.

Below is a list with display function.

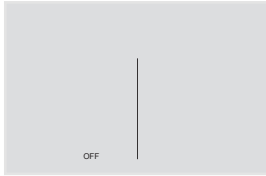

### Boiler Off Mode

Press the mode button to enable hot water and central heating.



### Boiler On Mode, no Heat Demand

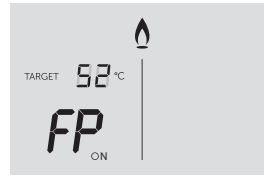

**Boiler is active for boiler frost protection:** operates if the ambient temperature is below 5°C until it reaches 19°C.



**Boiler is in Lockout for a specific error.** Display will show a number after the "L" to indicate which error is detected

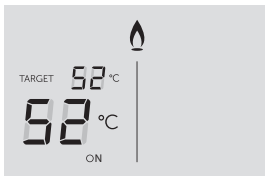













### Boiler is active for Central Heating

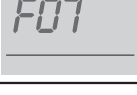

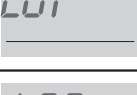
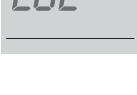
**Boiler has a fault for a specific error.** Display will show a number after the "F" to indicate which error is detected.

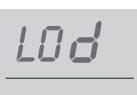
## 1.8 FAULT CODES

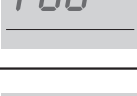
DISPLAY CODE ON BOILER	DESCRIPTION	ACTION
	Low Water Pressure	Check system water pressure is between 1 & 1.5bar on the system pressure gauge. To re-pressurise the system see Section 3. If the boiler still fails to operate then please contact Ideal (if under warranty) or alternatively a Gas Safe Registered Engineer if outside of the warranty period.
	Flame Loss	<ol style="list-style-type: none"> <li>1. Check other gas appliances in the house are working to confirm a supply is present in the property.</li> <li>2. If other appliances do not work or there are no other appliances, check the gas supply is on at the meter and/or pre payment meter has credit. If the boiler fails to operate then please contact Ideal (if under warranty) or alternatively a Gas Safe Registered Engineer if outside of the warranty period.</li> </ol>
	Fan Fault	Restart the appliance - if the boiler fails to operate then please contact Ideal (if under warranty) or alternatively a Gas Safe Registered Engineer if outside of the warranty period.
	Flow Thermistor	Restart the appliance - if the boiler fails to operate then please contact Ideal (if under warranty) or alternatively a Gas Safe Registered Engineer if outside of the warranty period.
	Return Thermistor	Restart the appliance - if the boiler fails to operate then please contact Ideal (if under warranty) or alternatively a Gas Safe Registered Engineer if outside of the warranty period.
	Outside Sensor Failure	Restart the appliance - if the boiler fails to operate then please contact Ideal (if under warranty) or alternatively a Gas Safe Registered Engineer if outside of the warranty period.
	Low Mains Voltage	Contact a qualified electrician or your electricity provider.
	Unconfigured PCB	Unconfigured/faulty PCB or gas valve short circuit. Please contact Ideal (if under warranty) or alternatively a Gas Safe Registered Engineer if outside of the warranty period.
	Flow Temperature Overheat or No Water Flow	Check system water pressure is between 1 & 1.5 bar on the system pressure gauge. To re-pressurise the system see Section 3. If the boiler fails to operate then please contact Ideal (if under warranty) or alternatively a Gas Safe Registered Engineer if outside of the warranty period.
	Ignition Lockout	<ol style="list-style-type: none"> <li>1. Check condensate Pipe for blockages</li> <li>2. Check other gas appliances in the house are working to confirm a supply is present in the property.</li> <li>3. If other appliances do not work or there are no other appliances, check the gas supply is on at the meter and/or pre payment meter has credit. If the boiler fails to operate then please contact Ideal (if under warranty) or alternatively a Gas Safe Registered Engineer if outside of the warranty period.</li> </ol>
	False Flame Lockout	Restart the appliance - if the boiler fails to operate then please contact Ideal (if under warranty) or alternatively a Gas Safe Registered Engineer if outside of the warranty period.
	5 Boiler Resets in 15 minutes	<ol style="list-style-type: none"> <li>1. Turn electrical supply to boiler off and on.</li> <li>2. If the boiler fails to operate please contact Ideal (if under warranty) or alternatively a Gas Safe Registered Engineer if outside of the warranty period.</li> </ol>
	Blocked Flue/Condensate	<ol style="list-style-type: none"> <li>1. Check condensate Pipe for blockages</li> <li>2. Check other gas appliances in the house are working to confirm a supply is present in the property.</li> <li>3. If other appliances do not work or there are no other appliances, check the gas supply is on at the meter and/or pre payment meter has credit. If the boiler fails to operate then please contact Ideal (if under warranty) or alternatively a Gas Safe Registered Engineer if outside of the warranty period.</li> </ol>
	Flow/Return Differential > 50°C	If the boiler fails to operate then please contact Ideal (if under warranty) or alternatively a Gas Safe Registered Engineer if outside of the warranty period.
	Diverter Valve in mid-position for service	Rotate all knobs fully clockwise, turn boiler power off and on then press restart.

Refer to Section 1.5



At Ideal Heating we take our environmental impact seriously, therefore when installing any Ideal Heating product please make sure to dispose of any previous appliance in an environmentally conscious manner. Households can contact their local authority to find out how. See <https://www.gov.uk/managing-your-waste-an-overview> for guidance on how to efficiently recycle your business waste.

#### Technical Training

Our Expert Academy offer a range of training options designed and delivered by our experts in heating. For details please visit: [expert-academy.co.uk](http://expert-academy.co.uk)

Ideal Boilers Ltd., pursues a policy of continuing improvement in the design and performance of its products. The right is therefore reserved to vary specification without notice.

Ideal is a trademark of Ideal Boilers.

Registered Office

Ideal Boilers Ltd., National Avenue, Hull, East Yorkshire, HU5 4JB

Tel 01482 492251 Fax 01482 448858

Registration No. London 322 137

EU Authorised Representative:

Atlantic SFDT

44 Boulevard des Etats-Unis, 85 000 La Roche-Sur-Yon, France

+33 (0)2 51 44 34 34

Ideal Technical Helpline: 01482 498663

Ideal Consumer Helpline: 01482 498660

Ideal Parts: 01482 498665

[idealheating.com](http://idealheating.com)

**ideal**  
HEATING