



# INSTALLATION & SERVICING

**LOGIC COMBI<sup>2</sup>**  
**C24 C30 C35**

When replacing any part on this appliance, use only spare parts that you can be assured conform to the safety and performance specification that we require. Do not use reconditioned or copy parts that have not been clearly authorised by Ideal Heating.

For the very latest copy of literature for specification and maintenance practices visit our website [idealheating.com](http://idealheating.com) where you can download the relevant information in PDF format.



## ERP DATA

	SYMBOL	UNITS	MODEL		
			24	30	35
Condensing Boiler	n/a	n/a	yes	yes	yes
Low Temperature Boiler	n/a	n/a	no	no	no
B1 Boiler	n/a	n/a	no	no	no
Cogeneration Space Heater	n/a	n/a	no	no	no
Equipped with a Supplementary Heater	n/a	n/a	no	no	no
Combination Heater	n/a	n/a	yes	yes	yes
<b>Nominal Heat Output for Space Heating</b>					
Full Load	P4	kW	24.3	24.3	24.3
Part Load	P1	kW	8	8	8
<b>Auxiliary Electricity Consumption</b>					
Full Load	elmax	kW	0.046	0.027	0.026
Part Load	elmin	kW	0.013	0.01	0.012
Standby	PSB	kW	0.002	0.003	0.002
<b>Seasonal Space Heating Energy Efficiency</b>					
Full Load	$\eta_4$	%	90	90	90
Part Load	$\eta_1$	%	98.7	98.7	98.7
Standby Loss	Pstby	kW	0.05	0.05	0.05
Ignition	Pign	kW	0	0	0
<b>Emissions</b>					
NOx (Gross)	NOx, pond Hs	mg/kWh	28	25	30
Annual Energy Consumption	QHE	GJ	75	75	75
Sound Power Level, Indoors	LWA	dB	50	46	46
<b>Domestic Hot Water</b>					
Domestic Hot Water	Qelec	kWh	0.157	0.157	0.158
Water heating energy efficiency (Eco) Tapping Profile L	$\eta_{WH}$	%	81	81	79
Daily fuel consumption 24hr (GCV) Actual measured	Qfuel	kWh	14.76	14.631	15.14
Annual electricity consumption	AEC	kWh	34	34	34
Annual fuel consumption	AFC	GJ	11	11	11



**WEEE DIRECTIVE 2012/19/EU**  
Waste Electrical and Electronic Equipment Directive

- At the end of the product life, dispose of the packaging and product in a corresponding recycle centre.
- Do not dispose of the unit with the usual domestic refuse.
- Do not burn the product.
- Remove the batteries.
- Dispose of the batteries according to the local statutory requirements and not with the usual domestic refuse.



The code of practice for the installation, commissioning & servicing of central heating systems



# PRODUCT FICHE

## LOGIC COMBI<sup>2</sup> C BOILER Ideal Heating ERP DATA

	SYMBOL	UNITS	MODEL		
			24	30	35
Condensing boiler			Yes		
Seasonal space heating efficiency class			A		
Rated heat output		kW	24		
Seasonal space heating energy efficiency	$\eta_s$	%	94*		
Annual energy consumption	$Q_{HE}$	GJ	75		
Sound power level, indoors	LWA	dB	50	46	46
Water heating energy efficiency class			A		

<b>Seasonal Space Heating Energy Efficiency of the Boiler</b>								<b>94%</b> <sup>*/%</sup>	<b>A</b>
<b>Temperature control (from fiche of temperature control)</b>								%	<b>B</b>
<i>Class I</i>	<i>Class II</i>	<i>Class III</i>	<i>Class IV</i>	<i>Class V</i>	<i>Class VI</i>	<i>Class VII</i>	<i>Class VIII</i>		
1%	2%	1.5%	2%	3%	4%	3.5%	5%		

### Solar Contribution (from fiche of solar device)

Collector Size  
(in m<sup>2</sup>)

Tank Volume  
(in m<sup>3</sup>)

Collector Efficiency  
(in %)

Tank rating  
A\* = 0.95  
A = 0.91  
B = 0.86  
C = 0.83  
D-G = 0.81

= ('III' x  + 'IV' x ) x 0.9 x (  / 100 x  ) = % **C**

**Seasonal Space Heating Energy Efficiency of Package**

**TOTAL: A+B+C=**

%

### Seasonal Space Heating Energy Efficiency Class of Package

<input type="checkbox"/>	<input type="checkbox"/>	<input type="checkbox"/>	<input type="checkbox"/>	<input type="checkbox"/>	<input type="checkbox"/>	<input type="checkbox"/>	<input type="checkbox"/>	<input type="checkbox"/>	<input type="checkbox"/>
<b>G</b>	<b>F</b>	<b>E</b>	<b>D</b>	<b>C</b>	<b>B</b>	<b>A</b>	<b>A+</b>	<b>A++</b>	<b>A+++</b>
< 30%	≥ 30%	≥ 34%	≥ 36%	≥ 75%	≥ 82%	≥ 90%	≥ 98%	≥ 125%	≥ 150%

The energy efficiency of the package of products provided for in this document may not correspond to its actual energy efficiency once installed in a building, as the efficiency is influenced by further factors such as heat loss in the products in relation to the building size and its characteristics.

## NOTES FOR THE INSTALLER

For any technical queries please ring the Ideal installer helpline : 01482 498663

### **BOILER RESTART PROCEDURE -**

**Press the RESTART button. The boiler will repeat the ignition sequence if a heat demand is present.**

## DEFINITIONS



**WARNING:** Risk of injury or death



**CAUTION:** Risk of damage to objects



**IMPORTANT:** Important information

---

## Table of Acronyms

**CH** - Central Heating

**DHW** - Domestic Hot Water

**TRV** - Thermostatic Radiator Valve

**PRV** - Pressure Relief Valve

**IE** - Ireland

**ETCI** - Electro-Technical Council of Ireland

**BS** - British Standard

**WRAS** - Water Regulations Advisory Scheme

**SAP** - Standard Assessment Procedure

**IET** - Institution of Engineering and Technology

**UKCA** - UK Conformity Assessed

**RHS** - Right Hand Side

**LHS** - Left Hand Side

**PCB** - Printed Circuit Board

---

# CONTENTS

<p>Section 1 - General..... 6</p> <p>1.1 Introduction..... 8</p> <p>1.2 Operation..... 8</p> <p>1.3 Safe Handling ..... 8</p> <p>1.4 Optional Accessories ..... 8</p> <p>1.5 Safety..... 9</p> <p>1.6 Safe Handling of Substances ..... 9</p> <p>1.7 Location of Boiler ..... 9</p> <p>1.8 Carbon Monoxide Alarms ..... 10</p> <p>1.9 Air Supply ..... 10</p> <p>1.10 Gas Supply ..... 10</p> <p>1.11 Water Circulation System ..... 10</p> <p>1.12 Boiler Controls ..... 10</p> <p>1.13 Electrical Supply ..... 11</p> <p>1.14 Condensate Drain..... 11</p> <p>1.15 Boiler Dimensions, Services &amp; Clearances ..... 12</p> <p>1.16 System Requirements - Central Heating ..... 13</p> <p>1.17 System Requirements - DHW..... 14</p> <p>1.19 Water Treatment ..... 14</p> <p>1.18 System Balancing..... 14</p> <p>Section 2 - Installation ..... 15</p> <p>2.1 Boiler Assembly - Exploded View ..... 15</p> <p>2.2 Unpacking..... 16</p> <p>2.3 Wall Mounting Template..... 17</p> <p>2.4 Preparing the Wall ..... 17</p> <p>2.5 Fitting the Wall Mounting Plate ..... 17</p> <p>2.6 Mounting the Boiler..... 17</p> <p>2.7 Flues and Locations..... 18</p> <p>2.8 Flues and Locations - Continued ..... 19</p> <p>2.9 Horizontal Flue Positions ..... 20</p> <p>2.10 Vertical Flue Positions ..... 20</p> <p>2.11 Flue System Dimensions ..... 21</p> <p>2.12 Fitting the Turret..... 21</p> <p>2.13 Cutting the Flue ..... 22</p> <p>2.14 Assembling the Vertical Flue ..... 23</p> <p>2.15 Condensate Drain..... 24</p> <p>2.16 Condensate Drain - Cont'd ..... 25</p> <p>2.17 Connections &amp; Filling..... 26</p> <p>2.18 Connections &amp; Filling Continued..... 27</p> <p>2.19 Electrical Connections ..... 28</p> <p>2.20 Installer Wiring..... 28</p> <p>2.21 External Wiring ..... 29</p> <p>2.22 Wiring Diagram..... 30</p> <p>2.23 Replacing Pre-Fitted Mains Cable..... 31</p> <p>2.24 Commissioning and Testing..... 32</p> <p>2.25 Initial Lighting..... 33</p> <p>2.26 The Display..... 34</p> <p>2.27 General Checks..... 34</p> <p>2.28 General Checks - Water Circulation ..... 35</p> <p>2.29 Restart Procedure..... 35</p> <p>2.30 Accessing the Installer Mode..... 36</p> <p>2.31 Handing Over..... 36</p>	<p>Section 3 - Servicing..... 37</p> <p>3.1 Servicing Schedule..... 37</p> <p>3.2 Removal / Replacement of Components ..... 38</p> <p>3.3 Draining the Boiler ..... 38</p> <p>3.4 Boiler Front Panel Removal / Replacement..... 39</p> <p>3.5 Flue Manifold Removal/Replacement..... 39</p> <p>3.6 Fan and Venturi Assembly Removal and Cleaning..... 40</p> <p>3.7 Burner Removal and Cleaning..... 41</p> <p>3.8 Cleaning the Heat Exchanger..... 41</p> <p>3.9 Ignition / Detection Electrode Replacement / Inspection ..... 42</p> <p>3.10 Cleaning / Replacing the Condensate Trap..... 42</p> <p>3.11 DHW Filter &amp; DHW Flow Regulator Cleaning/Replacement..... 43</p> <p>3.12 Burner Injector Replacement..... 43</p> <p>3.13 Burner Replacement..... 43</p> <p>3.14 Return Thermistor Replacement..... 44</p> <p>3.15 Spark Generator Replacement..... 44</p> <p>3.16 Gas Control Valve Replacement..... 45</p> <p>3.17 Diverter Valve Actuator Replacement..... 45</p> <p>3.18 Condensate Trap Replacement / Cleaning..... 46</p> <p>3.19 Primary PCB Replacement..... 46</p> <p>3.20 DHW Flow Turbine Sensor Replacement ..... 47</p> <p>3.21 Pressure Gauge Replacement ..... 47</p> <p>3.22 PRV Replacement ..... 48</p> <p>3.23 Pump Automatic Air Vent Replacement ..... 48</p> <p>3.24 Replacement of DHW Thermistor..... 49</p> <p>3.25 DHW Plate Heat Exchanger Replacement..... 49</p> <p>3.26 Diverter Valve Body Assembly Replacement..... 50</p> <p>3.27 Pump Head Replacement..... 51</p> <p>3.28 CH Water Pressure Switch Replacement..... 51</p> <p>3.29 Flow Thermistor Replacement..... 52</p> <p>3.30 Heat Engine Replacement..... 53</p> <p>3.31 Expansion Vessel Recharging &amp; Replacement ..... 54</p> <p>Section 4 - Fault Finding..... 55</p> <p>4.1 Fault Finding Main Menu ..... 55</p> <p>4.2 'L 01' - Overheat Lockout..... 56</p> <p>4.3 'L 02' - Ignition Lockout..... 56</p> <p>4.4 'L 06' - Flame On Before Gas Valve On..... 57</p> <p>4.5 'F 01' - Low Water Pressure ..... 57</p> <p>4.6 'F 02' - Flame Loss..... 57</p> <p>4.7 'F 03' - Fan Fault..... 58</p> <p>4.8 'F 04 or L 04' - Flow Thermistor Fault ..... 58</p> <p>4.9 'F 05 or L 05' - Return Thermistor Fault ..... 59</p> <p>4.10 'F 06' - Outside Sensor Fault..... 59</p> <p>4.11 No CH Operation but DHW Works OK ..... 60</p> <p>4.12 No DHW but CH Works OK..... 61</p> <p>4.13 No Display ..... 62</p> <p>4.14 'FOU' Flow/Return Differential Greater than 50°C ..... 62</p> <p>4.15 'F 0C' DHW Thermistor Fault..... 62</p> <p>Section 5 - Spare Parts ..... 63</p> <p>Section 6 - Benchmark to Commissioning..... 64</p>
--	---

# Section 1 - General

**Table 1 General Data**

		24	30	35
Gas Supply		2H - G20 - 20 mbar		
Gas Supply Connection		15 mm copper compression		
Injector Size	mm	4.15	4.65	4.9
Inlet Connection	Cold Water	15 mm copper compression		
Outlet Connection	Cold Hot Water	15 mm copper compression		
Flow Connection	Central Heating	22 mm copper compression		
Return Connection	Central Heating	22 mm copper compression		
Flue Terminal Diameter	mm	100		
Average Flue Temp-Mass Flow Rate	DHW	63°C - 11g/s	68°C - 13g/s	73°C - 15g/s
CO2 Content (± 0.7)	Max. DHW	9.2%	9.3%	9.7%
	Min. CH	8.5%	8.5%	8.8%
Maximum Working Pressure (Sealed Systems)	bar (psi)	2.5 (36.3)		
Maximum Domestic Hot Water Inlet Pressure	bar (psi) [kPa]	10.0 (145) [1000]		
Minimum Domestic Hot Water Inlet Pressure*	bar (psi) [kPa]	0.8(11.6)(80)	1.3(18.9) (130)	1.3(18.9)**(130)
Minimum DHW Inlet Pressure to Operate at 0.6 bar System Pressure		All Model Sizes 0.5 bar		
Electrical Supply		230 V ~ 50 Hz		
Power Consumption	W	96	91	110
Fuse Rating		External : 3 A Internal : T4A HRC L250 V		
Water Content	Central Heating litre (gal)	1.2 (0.26)		
	Domestic Hot Water litre (gal)	1.0 (0.22)		
Packaged Weight	kg	32.8	33	33
Lift Weight	kg	28.5	28.6	28.6
Boiler Casing Size	Height mm	700		
	Width mm	395		
	Depth mm	278		

\*Required for maximum flow rate. Boiler operates down to 2 L/min DHW delivery

\*\* In areas of low water pressure the DHW restrictor can be removed

**Table 2 Performance Data - Central Heating**

Boiler Input:		Max	Min		
			24	30	35
Net CV	kW	24.3	4.9	6.1	7.1
	Gross CV	27	5.4	6.7	7.9
Gas Consumption	m³/h	2.512	0.5	0.627	0.734
	(ft³/h)	(89)	(17.8)	(22)	(25.9)
Boiler Output :					
Non Condensing 70°C Mean Water Temp.	kW	24.2	4.8	6.1	7.1
Condensing 40°C Mean Water Temp.	kW	25.6	5.1	6.4	7.5
Seasonal Efficiency* SEDBUK 2005		91.10%	91.10%	91.10%	
Seasonal Efficiency* SEDBUK 2009/2012		89.60%	89.60%	89.60%	
NOx Classification		CLASS 6			

**Note.** Gas consumption is calculated using a calorific value of 38.7 MJ/m³ (1038 Btu/ft³) gross or 34.9 MJ/m³ (935 Btu/ft³) nett

To obtain the gas consumption at a different calorific value:

- For l/s - divide the gross heat input (kW) by the gross C.V. of the gas (MJ/m³)
- For Btu/h - multiply the gross heat input (kW) by 26.8
- For ft³/h - divide the gross heat input (Btu/h) by the gross C.V. of the gas (Btu/ft³)
- For m³/h - multiply l/s by 3.6

**Table 3 Performance Data - Domestic Hot Water**

Maximum DHW Input:		24	30	35
Nett CV	kW	24.3	30.4	35.4
	Gross CV	27	33.7	39.3
Gas Consumption	m³/h	2.512	3.135	3.657
	ft³/h	89	111	129
Maximum DHW Output	kW	24.2	30.3	35.3
DHW Flow Rate	l/min	9.9	12.4	14.5
	At 35°C Temp. Rise gpm	2.2	2.8	3.2
DHW Specific Rate	l/min	11.5	14.5	16.9
	gpm	2.5	3.2	3.7

\* The value is used in the UK Government's Standard Assessment Procedure (SAP) for energy rating of dwellings. The test data from which it has been calculated, has been certified by a notified body.

**C13 C33 C53** = A room sealed appliance designed for connection via ducts to a horizontal or vertical terminal, which admits fresh air to the burner and discharges the products of combustion to the outside through orifices which, in this case, are concentric. The fan is up stream of the combustion chamber.

**I<sub>2H</sub>** = An appliance designed for use on 2nd family gas, Group H only.

**II<sub>2H/3P</sub>** = An appliance designed for use on 2nd or 3rd family gases, Group H or P.

**LOGIC COMBI<sup>2</sup> C**

Natural Gas Only

BOILER SIZE	G.C. Appliance No (Benchmark No.)
24	47-349-93
30	47-349-94
35	47-349-95

Destination Country: GB

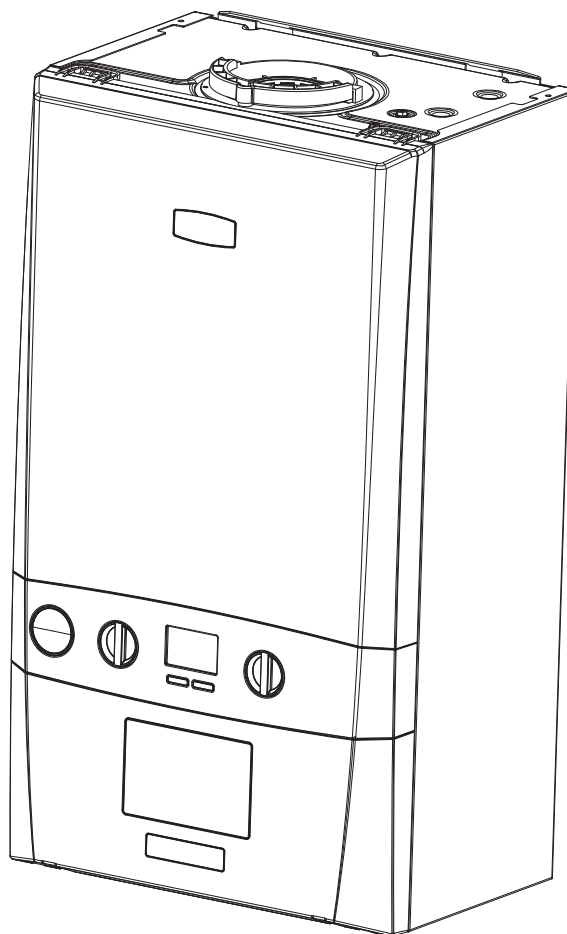

For UK, to comply with Building Regulations Part L1 (Part 6 in Scotland) the boiler should be fitted in accordance with the manufacturer's instructions. Self-certification that the boiler has been installed to comply with Building Regulations can be demonstrated by completing and signing the Benchmark Commissioning Checklist.

Before installing this boiler, read the Code of Practice sheet at the rear of this book.

**BENCHMARK COMMISSIONING CHECKLIST DETAILS**

<b>Boiler</b>	<b>Page</b>	<b>Page</b>	
Make and model.....	9	Burner operating pressure .....	n/a
Appliance serial no. on data badge .....	Front Cover	Central heating flow temp. ....	measure and record
SEDBUK No. %.....	8	Central heating return temp. ....	measure and record
<b>Controls</b>		<b>For combination boilers only</b>	
Time and temperature control to heating .....	29	Scale reducer .....	15
Time and temperature control to hot water .....	29	<i>Hot water mode</i>	
Heating zone valves.....	n/a	Heat input.....	to be calculated
TRV's.....	12	Max. operating burner pressure .....	n/a
Auto bypass .....	12	Max. operating water pressure.....	measure & record
Boiler interlock.....	12	Cold water inlet temp .....	measure & record
<b>For all boilers</b>		Hot water outlet temp.....	measure & record
Flushing to BS.7593.....	15	Water flow rate at max. setting.....	measure & record
Inhibitor .....	15	<b>For condensing boilers only</b>	
<i>Central heating mode</i>		Condensate drain.....	25-26
Heat input.....	to be calculated	<b>For all boilers:</b> Complete, sign & hand over to customer	

NOTE TO THE INSTALLER: COMPLETE THE BENCHMARK COMMISSIONING CHECKLIST AND LEAVE THESE INSTRUCTIONS WITH APPLIANCE



For assistance call Technical Helpline  
01482 498663

# Section 1 - General

## 1.1 INTRODUCTION

The Logic Combi<sup>2</sup> range of boilers are wall mounted, condensing, combination gas boilers.

Features:

- High efficiency
- Full sequence
- Automatic spark ignition
- Low water content
- Fanned flue

The boiler is supplied fully assembled with DHW plate heat exchanger, diverter valve, circulating pump, pressure gauge, PRV and CH expansion vessel.

Variable CH and DHW temperature controls are fitted on the user control and the boiler features a DHW preheat facility.

The boiler includes as standard:

- Automatic bypass
- Boiler frost protection
- Daily pump and diverter valve exercise.

The boiler casing is of white painted mild steel with a white polymer front panel.

The boiler temperature controls are visibly located in the control panel on the front of the boiler.

The heat exchanger is manufactured from cast aluminium.

The boiler is suitable for connection to fully pumped, sealed heating systems ONLY. Adequate arrangements for completely draining the system by provision of drain cocks MUST be provided in the installation pipework.

Pipework from the boiler is routed downwards.

### Data Plate

The boiler model and serial number can be located on the bottom of the boiler casing, shown in **1.15 Boiler Dimensions, Services & Clearances**.

## 1.2 OPERATION

With no demand for CH, the boiler fires only when DHW is drawn off, or periodically for a few seconds without any DHW draw-off, in order to maintain the DHW plate heat exchanger in a heated condition.

When there is a demand for CH, the heating system is supplied at the selected temperature of between 30°C and 80°C, until DHW is drawn off. The full output from the boiler is then directed via the diverter valve to the plate heat exchanger to supply a nominal DHW draw-off of

- 24 kW 9.9 l/min at 35°C temperature rise.
- 30 kW 12.4 l/min at 35°C temperature rise.
- 35 kW 14.5 l/min at 35°C temperature rise.

The DHW draw off rate specified above is the nominal that the boiler flow regulator will give. Due to system variations and seasonal temperature fluctuations DHW flow rates/temperature rise will vary, requiring adjustment at the draw off tap.

At low DHW draw-off rates the maximum temperature may exceed 65°C.

The boiler features a comprehensive diagnostic system which gives detailed information on the boiler status when operating, and performance of key components to aid commissioning and fault finding.

## 1.3 SAFE HANDLING

This boiler may require 2 or more operatives to move it to its installation site, remove it from its packaging base and during movement into its installation location. Manoeuvring the boiler may include the use of a sack truck and involve lifting, pushing and pulling.

Caution should be exercised during these operations.

Operatives should be knowledgeable in handling techniques when performing these tasks and the following precautions should be considered:

- Grip the boiler at the base.
- Be physically capable.
- Use personal protective equipment as appropriate, e.g. gloves, safety footwear.

During all manoeuvres and handling actions, every attempt should be made to ensure the following unless unavoidable and/or the weight is light.

- Keep back straight.
- Avoid twisting at the waist.
- Avoid upper body/top heavy bending.
- Always grip with the palm of the hand.
- Use designated hand holds.
- Keep load as close to the body as possible.
- Always use assistance if required.

## 1.4 OPTIONAL ACCESSORIES

Please visit [idealheating.com](http://idealheating.com) to access the optional accessories for this boiler.



## Section 1 - General

### 1.5 SAFETY

#### Current Gas Safety (installation and use) regulations or rules in force:

The appliance is suitable only for installation in GB and should be installed in accordance with the rules in force.

In GB, the installation must be carried out by a Gas Safe Registered Engineer. It must be carried out in accordance with the relevant requirements of the:

- Gas Safety (Installation and Use) Regulations
- Appropriate Building Regulations, either The Building Regulations, The Building Regulations (Scotland), Building Regulations (Northern Ireland).
- Water Fittings Regulations or Water byelaws in Scotland.
- Current IET Wiring Regulations.

Where no specific instructions are given, reference should be made to the relevant British Standard Code of Practice.

The Boiler has been tested and certified to:

BSEN 15502-1, BSEN 15502-2, BSEN 15502-2-1, BSEN 60335-1, BSEN 60335-2-102, BSEN 55014-1 and BSEN 55014-2 for use with Natural Gas & Propane.

Detailed recommendations are contained in the following British Standard Codes of Practice:

- BS5440:1** Flues (for gas appliances of rated input not exceeding 70 kW).
- BS5440:2** Ventilation (for gas appliances of rated input not exceeding 70 kW).
- BSEN12828** Heating Systems in buildings: Design for water based heating systems.
- BSEN12831** Heating Systems in buildings: Method for calculation of the design heat load.
- BSEN14336** Heating Systems in buildings: Installation and commissioning of water based heating systems.
- BS5546** Installation of gas hot water supplies for domestic purposes (2nd Family Gases)
- BS6798** Installation of gas fired hot water boilers of rated input not exceeding 70 kW.
- BS6891** Installation and maintenance of low pressure gas installation pipework.
- BS 7593:2019** Code of practice for the preparation, commissioning and maintenance of domestic central heating and cooling water systems.

#### Health & Safety Document No. 635.

#### The Electricity at Work Regulations, 1989.

The manufacturer's notes must NOT be taken, in any way, as overriding statutory obligations.

**IMPORTANT:** This appliance is UKCA/CE certificated for safety and performance. Do not connect external control devices directly to this appliance unless recommended in this manual or by **Ideal Heating** in writing. If in doubt, please enquire.

Unapproved control devices could invalidate the warranty of this appliance and infringe the Gas Safety Regulations.

### 1.6 SAFE HANDLING OF SUBSTANCES

No asbestos, mercury or CFCs are included in any part of the boiler or its manufacture.

### 1.7 LOCATION OF BOILER

The boiler must be installed on a flat and vertical internal wall, capable of adequately supporting the weight of the boiler and any ancillary equipment.

The boiler may be fitted on a combustible wall and insulation between the wall and the boiler is not necessary, unless required by the local authority.



**WARNING:** Rear access to the boiler is not permitted.



**CAUTION:** Do not fit the boiler outside.

#### Timber Framed Buildings

Boilers installed in a timber-framed building must comply with IGE/UP7 +A 2008.

#### Bathroom Installations



**CAUTION:** This appliance is IP20 rated, do not clean with jets of water.

You may install the boiler in any internal space. The installation must comply with the current IET (BS 7671) Wiring Regulations and the electrical regulations applicable in Scotland.

If the appliance is to be installed in a room containing a bath or shower then the appliance must be installed beyond Zone 2, as detailed in BS7671.

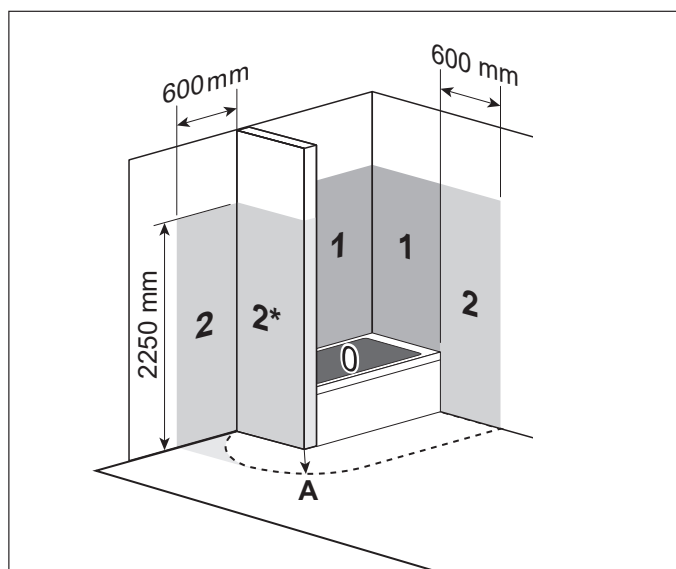

#### Bathroom Installations

[0] Zone 0

[1] Zone 1

[2] Zone 2

[2\*] Without the end wall, zone 2 must extend 600 mm from the bath

[A] 600 mm radius from the bath or shower

# Section 1 - General

## Compartment Installations

A boiler installed in a compartment does not require ventilation. However, A boiler installed in a compartment must provide adequate clearances for servicing. The compartment should also be fitted with a suitable label in accordance with current standards.

Refer to Section  
1.15

## 1.8 CARBON MONOXIDE ALARMS

When installing a new boiler, Installers should make sure that a suitable carbon monoxide alarm is installed near to the boiler.

**! IMPORTANT:** Carbon monoxide alarms must be installed in any room that has a fixed combustion appliance.

UK Building Regulations state that a carbon monoxide alarm should be installed in the room where:

- a new or replacement fixed combustion appliance (excluding an appliance used solely for cooking) is installed in the dwelling, or
- a new or replacement fixed combustion appliance is installed in a connected space such as an integral garage.

Users and Installers should comply with the Smoke and Carbon Monoxide Alarm (Amendment) Regulations 2022 and BS EN 50291-1:2010, and all applicable local building authority regulations.

Carbon monoxide detectors should use a battery designed to operate for the working life of the detector. Carbon monoxide detectors that are connected to the main electrical supply and comply with BS EN 50291-1:2010 (Type A) may be used, as long as a sensor failure warning device is installed. All detectors should include a warning device to alert the Users when the working life of the detector is scheduled to end.

## 1.9 AIR SUPPLY

It is not necessary to have an air vent in the room or internal space where the boiler is installed.

## 1.10 GAS SUPPLY

Consult the local gas supplier to establish an adequate supply of gas. Do not use existing service pipes without consulting the local gas supplier.

The gas supply must be governed with a meter.

A gas meter can only be connected by the local gas supplier or by a Gas Safe Registered Engineer.

An existing meter should be checked, preferably by the gas supplier, to ensure that the meter is adequate to deal with the required gas supply rate.

It is the responsibility of the Gas Installer to size the gas installation pipework in accordance with BS6891.

Whilst the principle of the 1:1 gas valve ensures the Logic range is able to deliver it is full output at inlet pressures as low as 14 mb, other gas appliances in the property may not be as tolerant. When operating pressures are found to be below the minimum meter outlet of 19 mb these should be checked to ensure this is adequate for correct and safe operation.

Allowing for the acceptable pressure loss of 1mb across the installation pipework, it can be assumed that a minimum permitted operating pressure of 18mb will be delivered to the inlet of the appliance.

(Reference BS6400-1 Clause 6.2 Pressure Absorption).

The external gas cock could further reduce the operating pressure when measured at its test point. The pressure drop is relative to the heat input to the boiler (kW), refer to graph below.

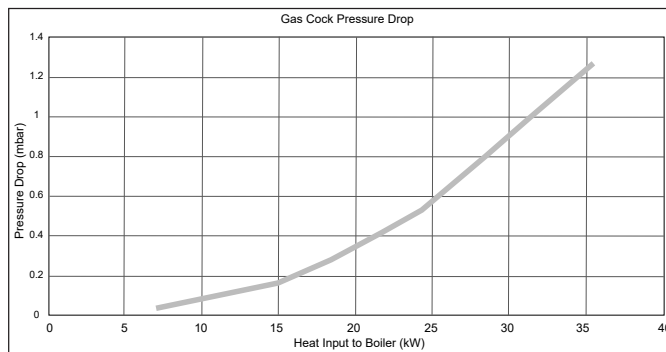

**! IMPORTANT:** Ensure all gas valve connections are gas tight with a gas soundness check up to the gas control valve.

Installation pipes must be fitted in accordance with BS6891.

The complete installation MUST be tested for gas tightness and purged as described, for the majority of installations the appropriate standard is IGEM/UP/1B [23], but alternatively IGEM/UP/1 [21] or IGEM/UP/1A [22], as appropriate, can be utilized.

## 1.11 WATER CIRCULATION SYSTEM

**! IMPORTANT:** A minimum length of 1 metre of copper pipe MUST be fitted to both flow and return connections from the boiler before connection to any plastic piping.

The central heating system should be in accordance with BS6798 and, in addition, for smallbore and microbore systems, BS EN 12828:2012+A1:2014.

Water treatment is covered later in these instructions.

Refer to Section  
1.19

## 1.12 BOILER CONTROLS

Install CH controls to ensure the boiler has no demand when there is no requirement from the system.

Heating systems with TRVs in individual rooms must include a thermostat to control the temperature in rooms without TRVs.

At least 10% of the minimum boiler heat output should be achieved using a room thermostat. A bypass circuit with an automatic bypass valve must be fitted to systems with TRVs or two-port valves on all the radiators to ensure water flow.

### 1.13 ELECTRICAL SUPPLY

---

 **WARNING:** This appliance must be earthed

Wiring external to the appliance MUST be in accordance with the current IET (BS7671) Wiring Regulations and any local regulations which apply.

The mains supply to the boiler and system wiring centre shall be through one common fused double pole isolator and for new heating systems, and where practical replacement installations, the isolator shall be situated adjacent to the appliance.

### 1.14 CONDENSATE DRAIN

---

The condensate drain provided must be connected to the drainage point on site. All condensate drainage pipework and fittings must be made of plastic.

 **IMPORTANT:** The condensate drain pipework should be installed in accordance with BS6798.

The drain outlet on the boiler is sized for standard 21.5 mm overflow pipe. It is a universal fitting to allow use of different brands of pipework.

Refer to Section  
2.15

## 1.15 BOILER DIMENSIONS, SERVICES & CLEARANCES

The boiler connections are made on the boiler connection tails.

**The following minimum clearances must be maintained for operation and servicing.**

Additional space will be required for installation, depending upon site conditions.

### Side and Rear Flue

- a. Provided that the flue hole is cut accurately, e.g. with a core drill, the flue can be installed from inside the building where wall thicknesses do not exceed 600 mm.

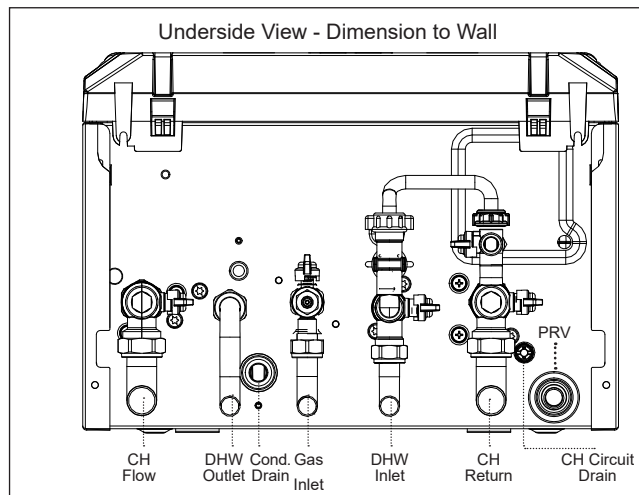
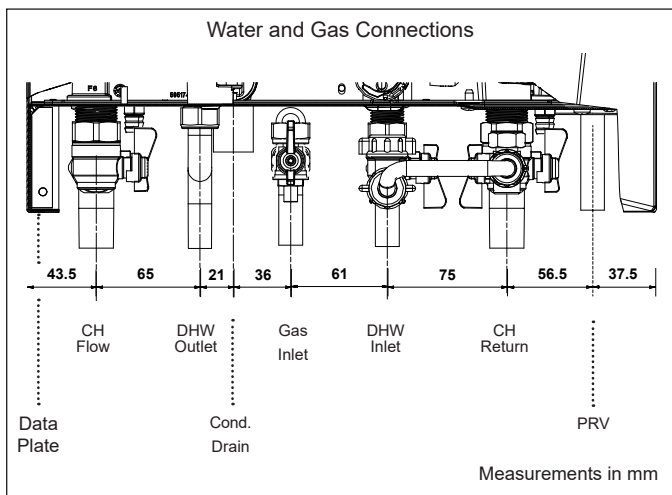
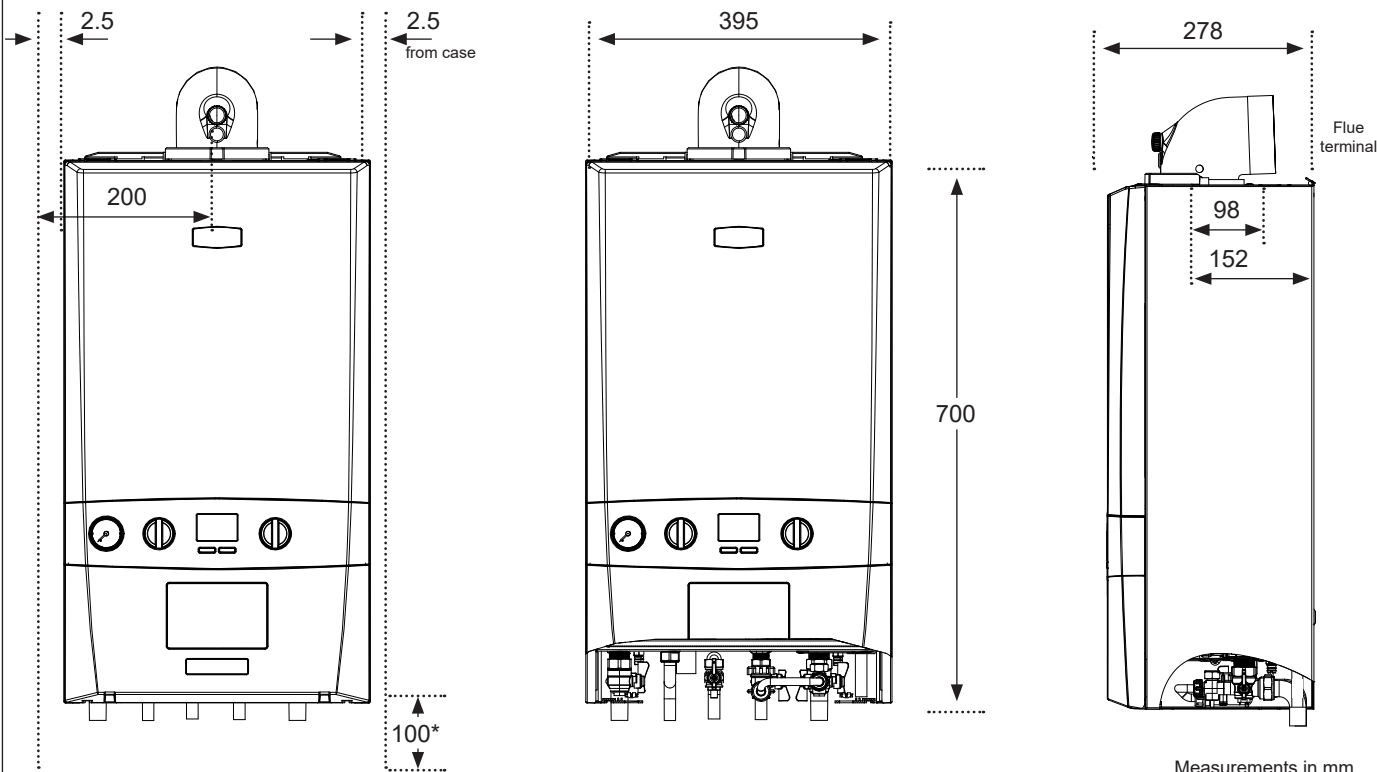

### Front Clearance

The minimum front clearance when built in to a cupboard is 5 mm from the cupboard door but 450 mm overall clearance is still required, with the cupboard door open, to allow for servicing.

### \* Bottom Clearance

Bottom clearance after installation can be reduced to 5 mm.

This must be obtained with an easily removable panel to provide the 100 mm clearance required for servicing.

**IMPORTANT:** Please ensure there is sufficient clearance either side and below the boiler, particularly from door hinges and the base of a cupboard.

## 1.16 SYSTEM REQUIREMENTS - CENTRAL HEATING

- a. The method of filling, refilling, topping up or flushing sealed primary hot water circuits from the mains via a temporary hose connection is only allowed if acceptable to the local water authority.
- b. Antifreeze fluid, corrosion and scale inhibitor fluids suitable for use with boilers having aluminium heat exchangers may be used in the central heating system.

### General

1. The installation must comply with national and local regulations.
2. Design the system for flow temperatures up to 80°C.
3. The system components must be suitable for an operating pressure of 3 bar and a maximum temperature of 110°C.

The following components are incorporated within the appliance:

- a. Circulating pump.
- b. PRV, with a non-adjustable preset lift pressure of 3 bar.
- c. Pressure gauge, covering a range of 0 to 4 bar.
- d. An 8 litre expansion vessel, with an initial charge pressure of 0.75 bar.

4. **Makeup Water.** One of the following provisions must be made for replacing system water loss:

- a. Manually filled vessel

The vessel must:

Have a visible water level

Be mounted at least 150 mm above the system's highest point

Connect through a non-return valve to the system

Be at least 150 mm below the makeup vessel on the return side of the radiators

- b. System prepressurisation.

The efficiency of the expansion vessel will be reduced in a pressurised system; a larger vessel or smaller system volume may be necessary. If the vessel's capacity is not sufficient, an additional vessel must be installed on the return to the boiler.

If the system is not pressurised, the cold water capacity must not exceed 143 litres.

Guidance on vessel sizing is given in table above.

### Water Flow Rate and Pressure Loss

Max CH Output	kW	24.2
Water Flow Rate	l/min	17.3
	(gal/min)	(3.8)
Temperature Differential	°C	20
Head available for System	m.w.g.	3.4
	(ft.w.g.)	(11.1)

**Table 4 Vessel Sizing**

<b>PRV setting</b>	bar	3.0	
<b>Vessel charge pressure</b>	bar	0.5 to 0.75	
<b>System pre-charge pressure</b>	bar	None	1.0
<b>System volume (litres)</b>	<b>Expansion vessel volume (litres)</b>		
	25	1.6	1.8
	50	3.1	3.7
	75	4.7	5.5
	100	6.3	7.4
	125	7.8	9.2
	150	9.4	11.0
	175	10.9	12.9
	190	11.9	14.0
	200	12.5	14.7
250	15.6	18.4	
300	18.8	22.1	
<b>For other system volumes multiply by the factor across</b>		0.063	0.074

### 5. Filling

The system may be filled by the following method:

Where the mains pressure is excessive a pressure reducing valve must be used to facilitate filling.

- a. Thoroughly flush out the whole system with cold water.
- b. Fill and vent the system until the pressure gauge registers 1 bar and examine for leaks.

Refer to Section 2.18

- c. Check the operation of the PRV by raising the water pressure until the valve lifts. This should occur within 0.3 bar of the preset lift pressure.
- d. Check no escape of water occurs except at the discharge point
- e. Release water from the system until the minimum system design pressure is reached; 1.0 bar if the system is to be pre-pressurised.

### DOMESTIC HOT WATER

1. The DHW service must be in accordance with BS5546 & BS6700.
2. Refer to Table 1 for minimum and maximum working pressures. In areas of low mains water pressures the domestic hot water regulator may be removed from the DHW flow turbine cartridge. The boiler will require the flow rate to be set to obtain a temperature rise of 35°C at the tap furthest from the boiler.

Refer to Section 1.2

3. The boilers are suitable for connection to most types of washing machine and dishwasher appliances.

### 1.17 SYSTEM REQUIREMENTS - DHW

4. If the shower/mixer valve does not incorporate non-return valves the following must be followed:
  - a. The cold inlet to the boiler is fitted with an approved anti-vacuum or syphon non-return valve.
  - b. Hot and cold water supplies to the shower are of equal pressure.
5. **Hard Water Areas** Where the water hardness exceeds 200 mg/ litre (200 ppm), it is recommended that a proprietary scale reducing device is fitted into the boiler cold supply within the requirements of the local water company.

**!** **IMPORTANT** Provision must be made to accommodate the expansion of DHW contained within the appliance. If the DHW inlet contains a back flow prevention device or non-return valve, e.g. a water meter, then a mini expansion vessel should be fitted between the device and the boiler in the cold inlet pipe.

Cold water, rising main and pipework in exposed areas need to be suitably lagged to prevent freezing.

**Note** DHW Expansion Vessel kit available from Ideal.

### 1.18 SYSTEM BALANCING

The boiler does not normally need a bypass but at least some radiators on the heating circuit, of load of at least 10% of the minimum boiler output, must be provided with twin lockshield valves so that this minimum heating load is always available. See note regarding thermostatic radiator valves on page 10.

**Note.** Systems incorporating zone valves which could completely cut off the flow through the system must also include a bypass.

#### Balancing

1. Set the programmer to ON.
 

Close the manual or thermostatic valves on all radiators, leaving the twin lockshield valves (on the radiators referred to above) in the OPEN position.

Turn up the room thermostat and adjust the lockshield valve to give an uninterrupted flow through the radiator. These valves should now be left as set.
2. Open all manual or thermostatic radiator valves and adjust the lockshield valves on the remaining radiators, to give around 20°C temperature drop at each radiator.
3. Adjust the room thermostat and programmer to NORMAL settings.

### 1.19 WATER TREATMENT

#### Central Heating

The Logic range of boilers have an ALUMINIUM alloy heat exchanger.

**IMPORTANT** The application of any other treatment to this product may render the guarantee of Ideal Heating invalid.

**Ideal Heating** recommend Water Treatment in accordance with the Benchmark Guidance Notes on Water Treatment in Central Heating Systems.

If water treatment is used **Ideal Heating** recommend only the use of SCALEMASTER SM-1 PRO, FERNOX, MBI, ADEY MC1, SENTINEL X100 or CALMAG CM100 inhibitors and associated water treatment products, which must be used in accordance with the manufacturers' instructions.

This boiler can be used with a water softener. However, the heating system should not be filled with softened water as any softening chemicals could enhance corrosion of certain materials in the heating system, including aluminium and steel. The heating system should always be filled from the bypass on the water softener installation.

1. It is most important that the correct concentration of the water treatment products is maintained in accordance with the manufacturers' instructions.
2. If the boiler is installed in an existing system any unsuitable additives **MUST** be removed by thorough cleansing. BS7593:2019 details the steps necessary to clean a domestic heating system.

3. In hard water areas, treatment to prevent lime scale may be necessary.
4. Under no circumstances should the boiler be fired before the system has been thoroughly flushed.

#### Domestic Hot water

In hard water areas where mains water can exceed 200ppm Total Hardness (as defined by BS 7593 Table 2) a scale reducing device should be fitted into the boiler cold supply within the requirements of the local water company. The mains cold water feed can come from a water softener as the materials used in the domestic hot water circuit are fully resistant to any chemicals in softened water.

**Ideal Heating** recommend the use of Fernox Quantomat, Sentinel Combiguard, Calmag CalPhos I scale reducing devices or Scalemaster In-line Scale Inhibitor branded Ideal, which must be used in accordance with the manufacturers' instructions.

For further information contact:

Fernox - [www.fernox.com](http://www.fernox.com). Tel: +44 (0) 3301 007750

Sentinel Performance Solutions

[www.sentinelprotects.com](http://www.sentinelprotects.com). Tel: +44 (0) 1928 704330

Scalemaster Water Treatment Products

[www.scalemaster.co.uk](http://www.scalemaster.co.uk). Tel: +44 (0) 1785 811636

Calmag Ltd. - [www.calmag Ltd.com](http://www.calmag Ltd.com).

Tel: +44 (0) 1535 210320

Adey - [www.adey.com](http://www.adey.com). Tel: +44 (0) 1242 546700

## 2.1 BOILER ASSEMBLY - EXPLODED VIEW

- |                                  |                           |   |                                |
|----------------------------------|---------------------------|---|--------------------------------|
| 104 CH Return Valve              | 119 Return Group Manifold | 218 Gasket - Burner                       | 313 Ignition Lead              |
| 105 CH Flow Valve                | 120 Flow Group Manifold   | 219 Sump Clean Out Cover                  | 324 Control Box Lid            |
| 106 DHW Inlet & Outlet           | 121 Plate Heat Exchanger  | 223 Flue Manifold                         | 325 Control Box Front          |
| 107 Filling Loop Pipe            | 124 Flow Regulator        | 224 Flue Manifold Top                     | 326 Blank Insert               |
| 108 Pump Head                    | 127 Flow Sensor/Turbine   | 227 Clamp Retaining Flue Turret           | 401 Heat Engine                |
| 110 Auto Air Vent                | 131 Water Pressure Switch | 228 Hose Condensate Internal              | 503 Wall Mounting Bracket      |
| 111 Diverter Valve Motor         | 135 Pressure Gauge        | 229 Condensate Trap                       | 504 Front Panel                |
| 112 Diverter Valve Body & Paddle | 203 Gas Cock              | 231 Condensate Outlet Connection          | 505 Fascia                     |
| 113 Pressure Relief Valve        | 205 Gas Valve             | 239 Condensate Drain Tube                 | 506 Bracket - Spark Generator  |
| 114 Pipe - PRV Outlet            | 206 Pipe - Gas Injector   | 302 PCB                                   | 507 Bracket - Expansion Vessel |
| 115 Pipe - Flow                  | 211 Injector Assy         | 306 Ignition/Detection Electrode          |                                |
| 116 Pipe - Return                | 214 Venturi               | 308 Ignitor Unit                          |                                |
| 117 Pipe - Expansion Vessel      | 215 Fan                   | 309 Heat Exchanger Flow Thermistor & Seal |                                |
| 118 Expansion Vessel             | 217 Burner                |   |                                |

Note that item numbers are linked to the spares list

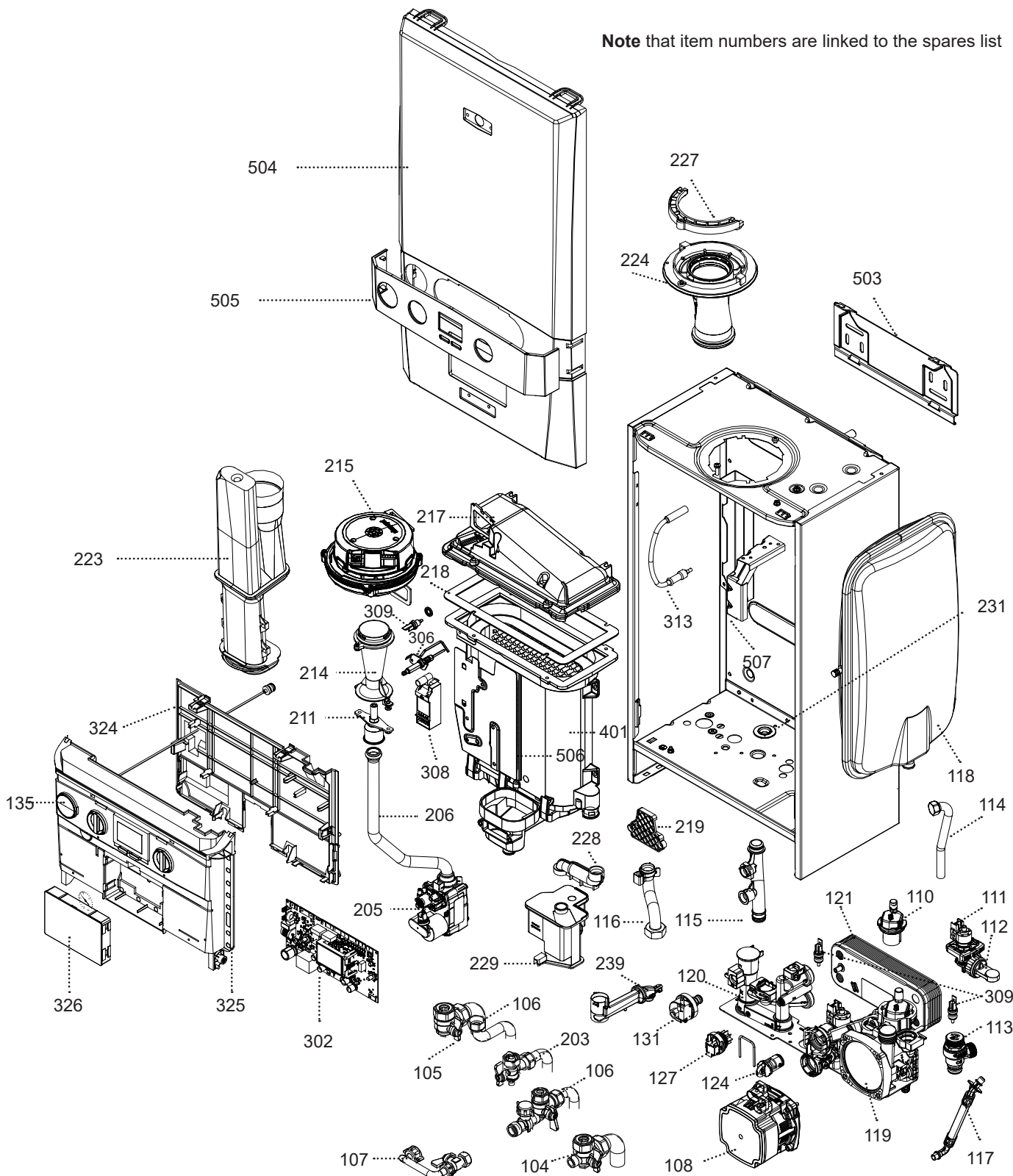

## 2.2 UNPACKING

The boiler is supplied fully assembled in Pack A.

### Pack A Contents

1. Boiler
2. Hardware Pack Box
3. Wall Mounting Plate
4. These Installation/Users Instructions
5. Boiler Warranty
6. Wall Mounting Template

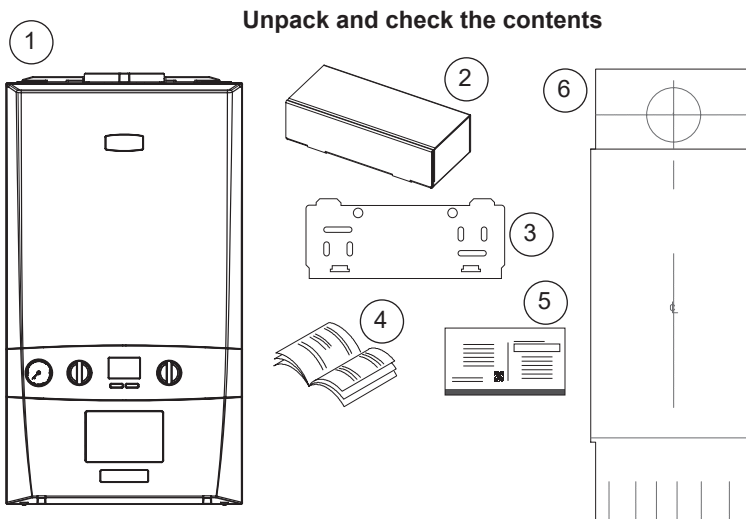

### Hardware Pack

#### Box Contents

7. 1x HP Box Dividers - 289 x 111 x 57.5 mm
8. 1x Plug Male and Clip
9. 1x Pipe DHW Outlet
10. 1x Pipe Filling Loop
11. 1x Valve DHW Inlet
12. 2x Pipe CH Flow/Return
13. 1x Valve Filling Loop
14. 1x Valve CH G<sup>3</sup>/<sub>4</sub> x 22 mm Filling Loop
15. 1x Cap Female
16. 1x Valve CH G<sup>3</sup>/<sub>4</sub> x 22 mm
17. 1x Pipe DHW Inlet
18. 1x Nut G<sup>1</sup>/<sub>2</sub>16 Brass (Flat)
19. 1x Gas Cock

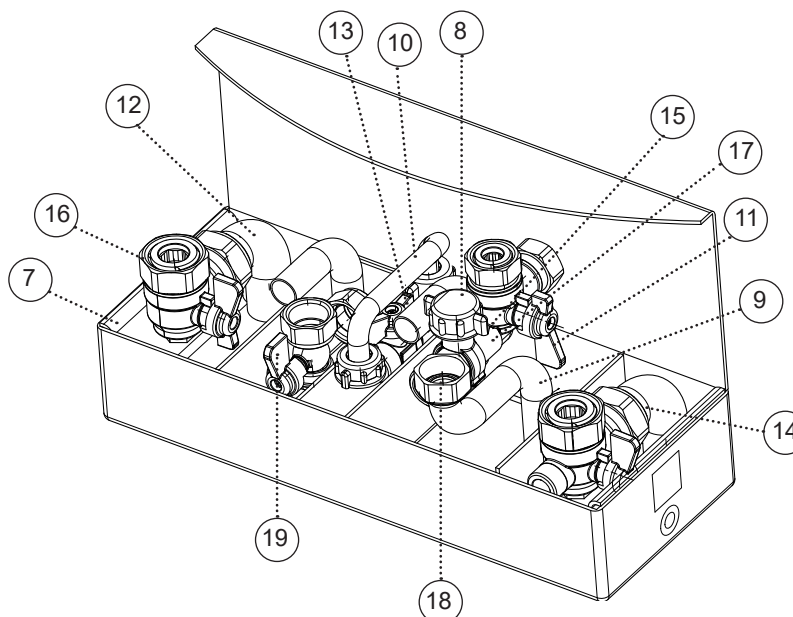

#### Accessory Bag Contents

20. 9x Washers\*
21. 2x Wall Plugs
22. 2x Screws
23. 1x Flue Clamp Screw

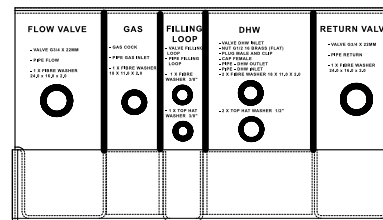
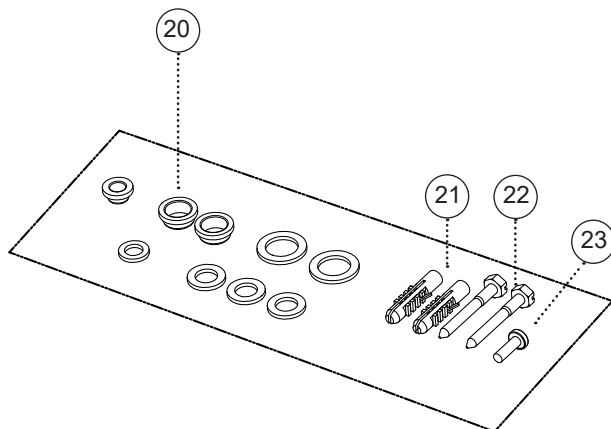

\*Refer to Valve Washer Template inside box lid.

## 2.3 WALL MOUNTING TEMPLATE

The wall mounting template is located on the internal protective packaging. The template shows the position of the fixing and rear flue centre holes for a standard installation

Care **MUST** be taken to ensure the correct holes are drilled.

1. Secure the template into the required position. Ensure it is square by hanging a plumbline.
2. If fitting a side flue, extend the flue centreline onto the side by 155 mm on a standard wall fix or 200 mm if using a stand-off bracket.
3. Mark the following on to the wall:
  - a The selected group of wall mounting screw holes.
  - b. The centre position of the flue duct. Marking both the centre and the circumference of the flue duct.
4. Remove the template plate from the wall.

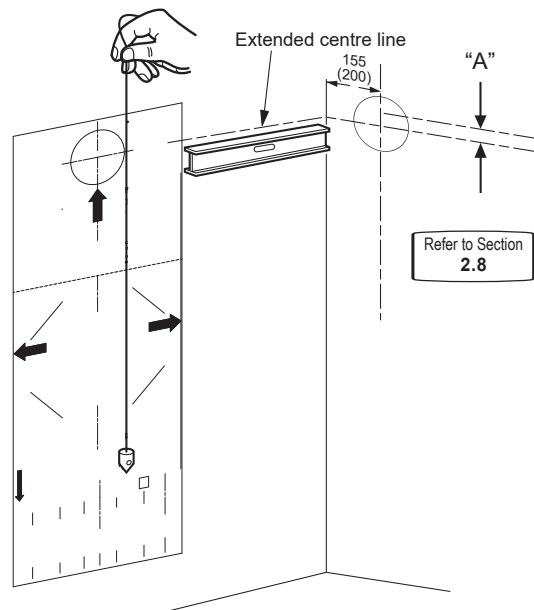

## 2.4 PREPARING THE WALL

**WARNING:** Ensure that, during the cutting operation, masonry falling outside of the building does not cause damage or personal injury.

1. Check all of the hole positions before drilling.
2. Cut the flue hole with a 127 mm core boring tool, ensure the hole is square to the wall.
3. Drill the 2 mounting holes with a 7.5 mm / 8 mm masonry drill and insert the plastic plugs provided.
4. Locate 2 No.14 x 50 mm screws in the wall mounting plate (one at each side, in any of the 3 holes provided at each side) and screw home. Ensure mounting bracket is level.

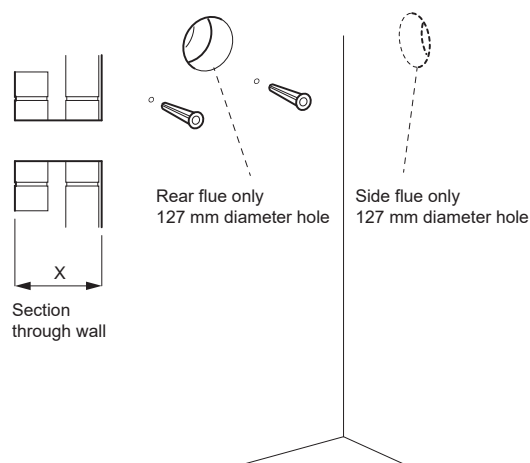

## 2.5 FITTING THE WALL MOUNTING PLATE

1. Screw the wall mounting plate to the wall using 2 wall plugs fitted previously with the 2 screws provided.
2. Choose one of the 2 sets of slots in left and right bank. Ensure that at least one of the screws is fitted into a top slot and the mounting bracket is level.

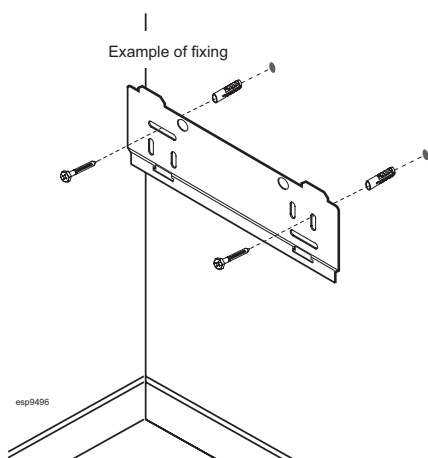



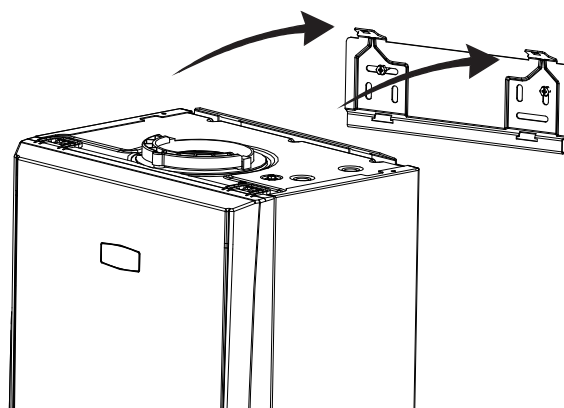

## 2.6 MOUNTING THE BOILER

1. Lift the boiler onto the wall mounting plate and locate it over the 2 tabs.

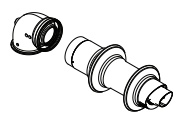
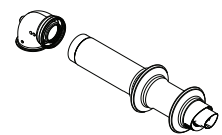
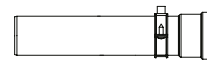
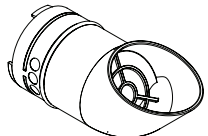
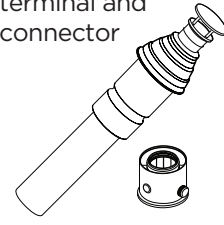

## 2.7 FLUES AND LOCATIONS

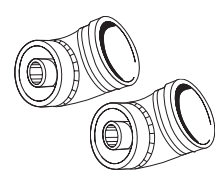
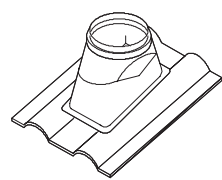
These Installation & Servicing Instructions must be read with all other instructions that may be supplied with the flue components. The Flue Guide can be downloaded from: <https://idealheating.com/logic-V4-literature-11>. Also available is an online video that shows you how to install the flue pipework.

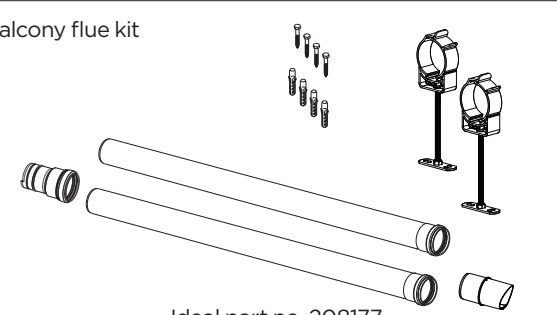
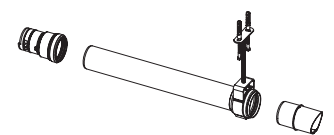
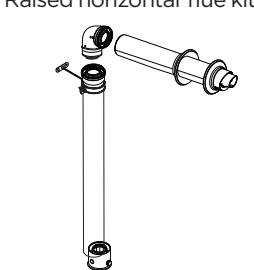
<p>Telescopic horizontal flue 0.5 or 0.7 m</p>  <p>Ideal part no. 0.5 m 208169 0.7 m 208174</p>	<p>Horizontal flue 0.6 or 0.8 m</p>  <p>Ideal part no. 0.6 m 208171 0.8 m 217442</p>	<p>Flue extension 0.5 m, 1 m or 2 m</p>  <p>Ideal part no. 0.5 m 211037 1 m 203129 2 m 211038</p>	<p>Flue deflector</p>  <p>Ideal part no. 208176</p>	<p>Vertical flue terminal and connector</p>  <p>Ideal part no. 211039</p>
<p>Flue elbow 90°</p>  <p>Ideal part no. 203130</p>	<p>Flue elbow 45°</p>  <p>Ideal part no. 203131</p>	<p>Weather collar pitched roof</p>  <p>Ideal part no. 152258</p>	<p>Weather collar flat roof</p>  <p>Ideal part no. 152259</p>	
<p>Balcony flue kit</p>  <p>Ideal part no. 208177</p>		<p>Soffit kit</p>  <p>Ideal part no. 211302</p>	<p>Raised horizontal flue kit</p>  <p>Ideal part no. 208290</p>	

**WARNING:**

- It is critical that products of combustion cannot re-enter the building
- The flue terminal must always have a free passage of air.

**CAUTION:**

- White sections of the flue must not be visible outside.
- Install a flue terminal guard where the flue terminal is less than 2 metres above a platform where persons can walk or come into contact with the terminal.
- Water is the only permitted lubricant for flue assembly.

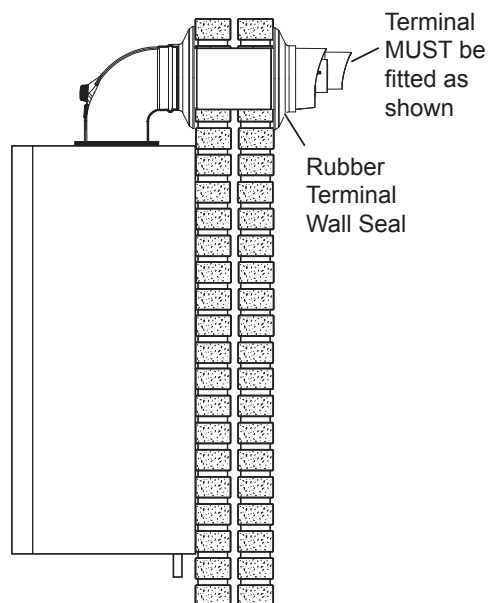

FLUE OUTLET

2.8 FLUES AND LOCATIONS - CONTINUED

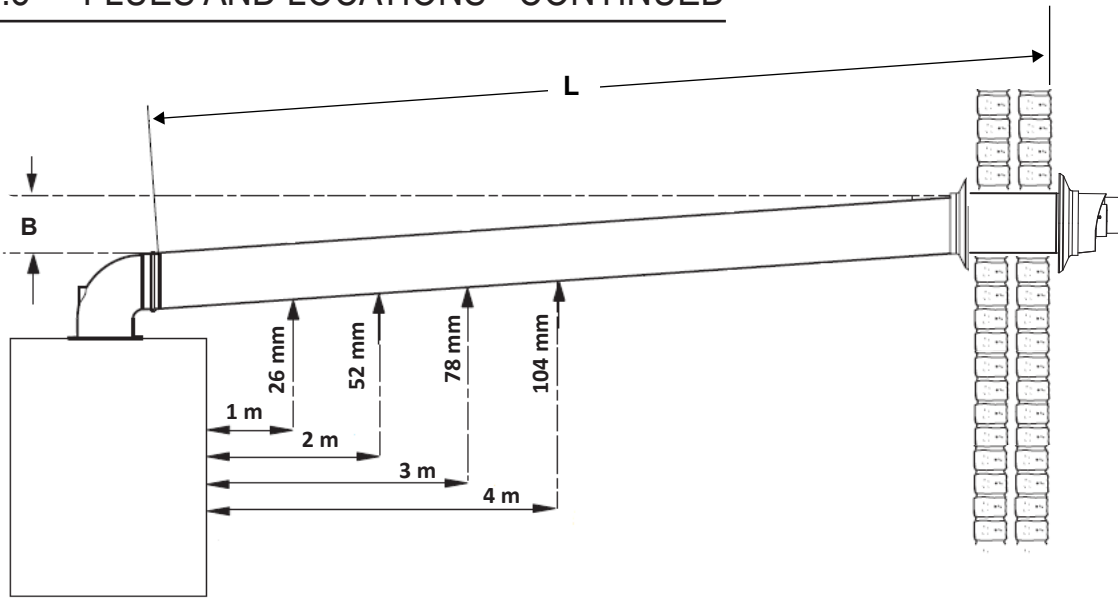

\* Ensure the flue terminal is horizontal when passing through the wall. Any flue extensions should be fitted with a 1.5° decline.

**B = Top Clearance**

Top Clearance is measure from the top of the turret to the top of the hole where the flue terminates.

**L = Effective flue length.**

The effective length of the flue is measured from the edge of the turret to the flue terminal lip.

Flue systems that require extension kits must be installed with a 1.5° decline from the flue terminal back to the boiler. A 1.5° decline can be achieved by designing the flue with a 26 mm rise per meter length of flue.

**IMPORTANT INFORMATION**

Install the flue in accordance to BS 5440:1 2008  
Position the terminal, so the products of combustion do not cause a nuisance.

The terminal outlet duct must not be closer than 25 mm to combustible material.

The flue is secured in the wall using either sand and cement or heatproof silicone.

The flue must be supported by a bracket every metre of flue length and at every change of direction. Concealed flues must have inspection hatches no more than 1.5 metres from joints.

Where possible inspection hatches should be located at change of directions. Where this is not possible then bends must be viewable from both sides.

Inspection hatches must be at least 300 mm<sup>2</sup>.

Horizontal	Maximum Effective Flue Length
24 kW	9.0 metres
30 kW	8.0 metres
35 kW	6.0 metres
Vertical	
24/30/35 kW	7.5 metres
Elbows increase resistance and have an effective flue length equivalence. The following table is an example.	
Part	Resistance
45° elbow	0.6 metres
90° elbow	1.0 metres

Table 5 - Flue Terminal Position

Flue Terminal Positions	Min. Spacing*
1. Directly below, above or alongside an opening.	300 mm
2. Below guttering, drain pipes or soil pipes.	75 mm 25 mm*
3. Below eaves.	200 mm 25 mm*
4. Below balconies or a car port roof.	200 mm 25 mm*
5. From vertical drain pipes or soil pipes.	150 mm 25 mm*
6. From an internal or external corner or a boundary alongside the terminal.	300 mm 25 mm*
7. Above adjacent ground, roof or balcony level.	300 mm
8. From a surface or a boundary facing the terminal.	600 mm
9. From a terminal facing a terminal.	1200 mm
10. From an opening in a car port into dwelling.	1200 mm
11. Vertically from a terminal on the same wall.	1500 mm
12. Horizontally from a terminal wall.	300 mm
13. Horizontally from an adjacent window	600 mm
14. Facing an opening into an adjacent building	2000 mm
15. At an angle to the boundary	90° 300 mm 45° 600 mm
16. Parallel to a boundary	300 mm
17. Below ground level – open light well	
a) Below ground	<1,000 mm
b) Above floor level	300 mm
c) From side	300 mm
d) From facing surface	600 mm
<b>*Only one reduction down to 25mm is allowed per installation.</b>	

FLUE OUTLET

## 2.9 HORIZONTAL FLUE POSITIONS

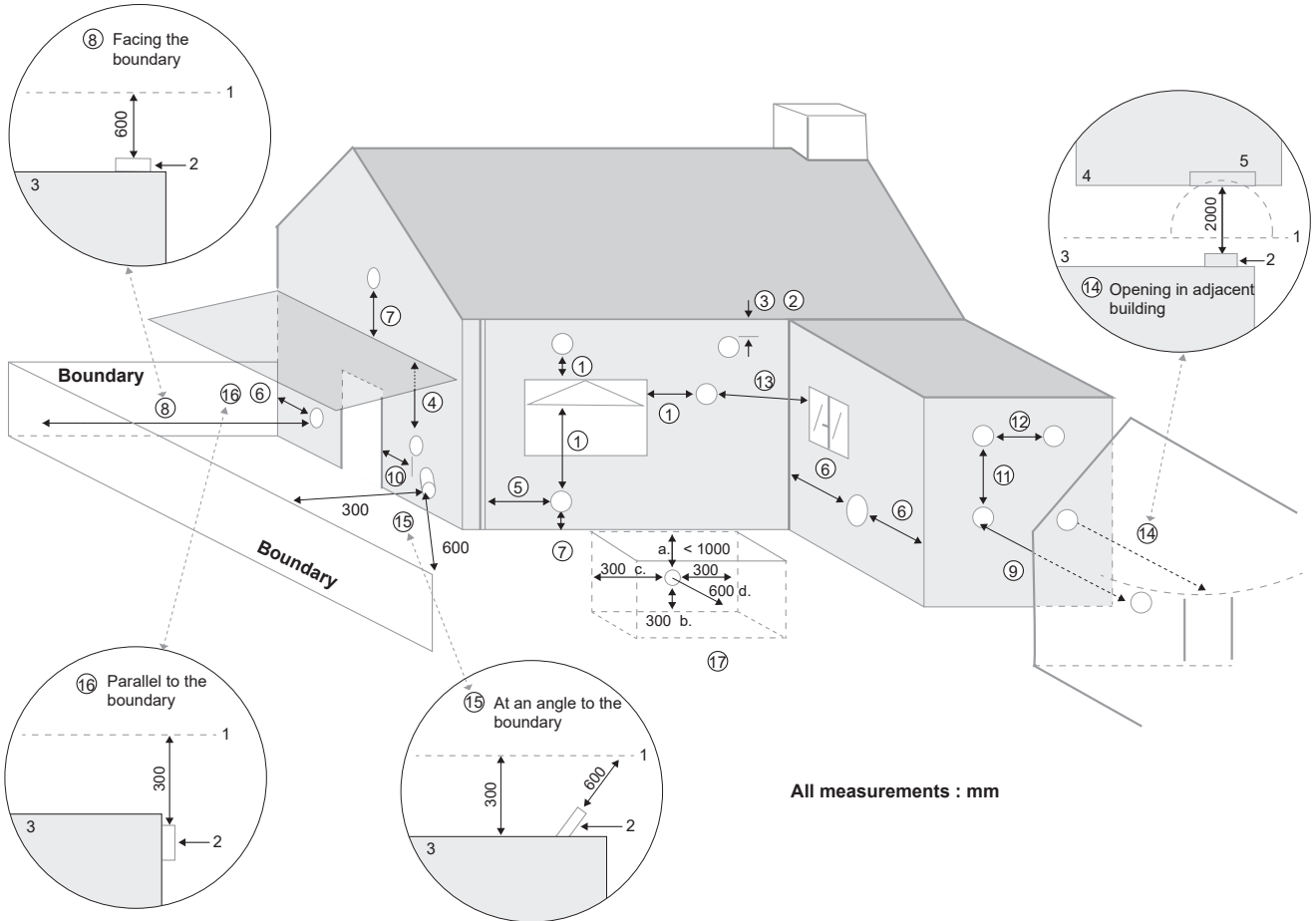

Refer to Table 5

## 2.10 VERTICAL FLUE POSITIONS

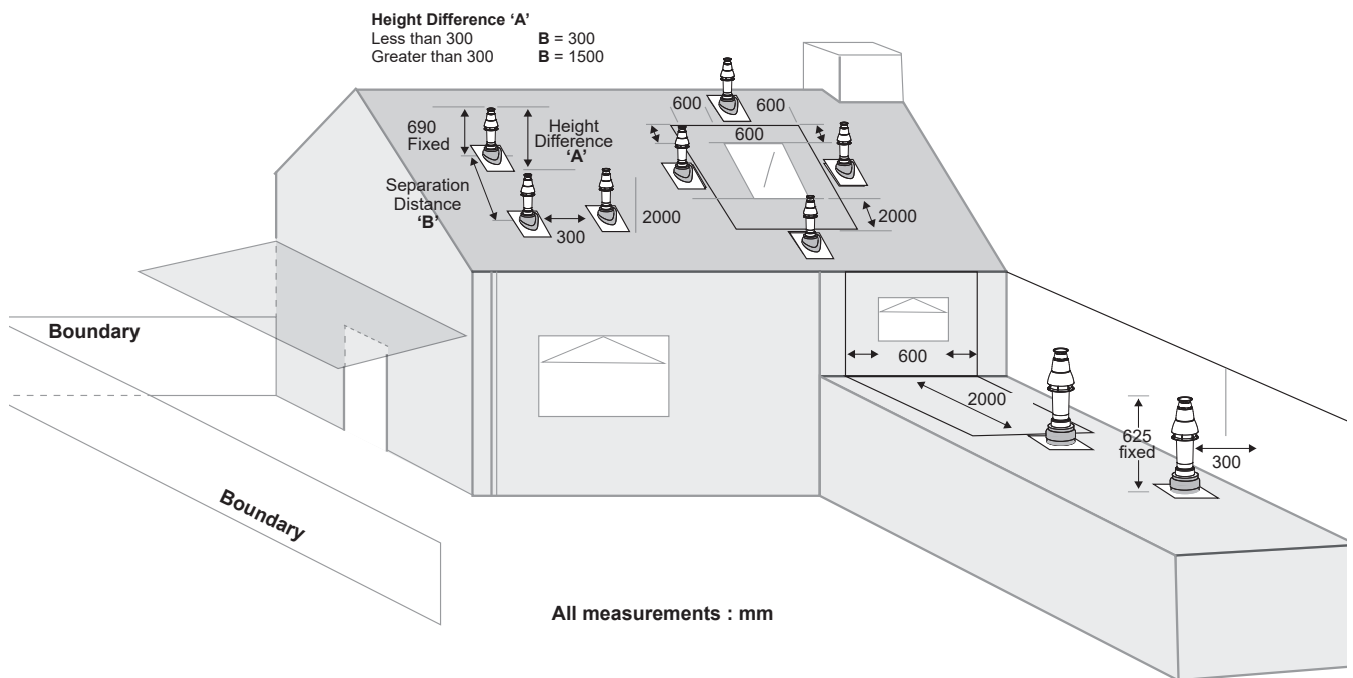

Refer to Table 5

## 2.11 FLUE SYSTEM DIMENSIONS

### Flue Design

#### ⚠ IMPORTANT:

1. Flue lengths may vary, always measure flue lengths before cutting.
2. Effective flue length and actual flue length are different measurements.
3. Effective flue length is made up of the flue length equivalence and the flue sections between the turret, elbows and terminal.
4. Actual flue length is the amount of flue needed to achieve the effective flue length, this includes insertions.
5. It is recommended that a support bracket is fitted on every 1 metre of pipe work used and the bracket is located as close to the collar as possible. The bracketing must ensure a 1.5 degree fall back to the appliance.

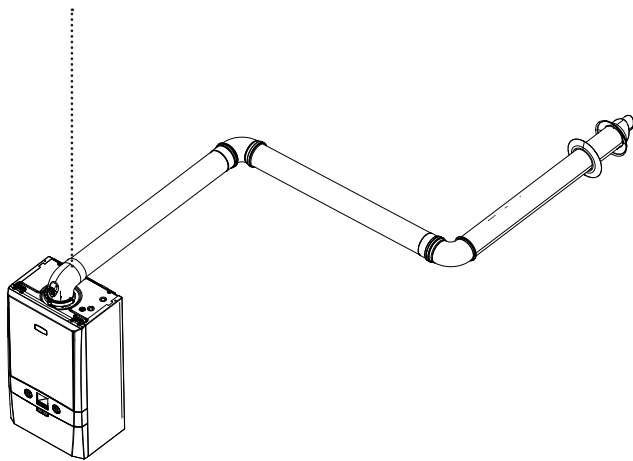
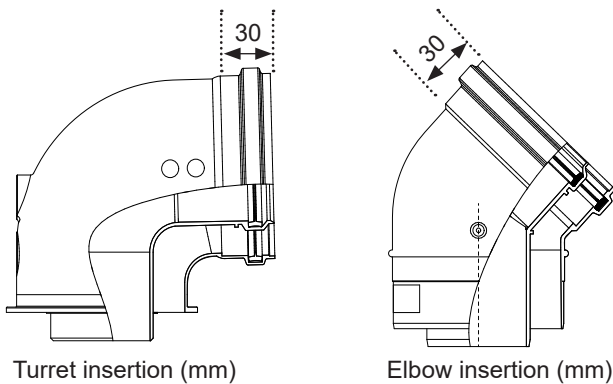

Part	Actual Length	Insertion	Effective Length
1 m flue length	1000 mm	30 mm	970 mm
90° elbow		n/a	1000 mm
1 m flue length	1000 mm	30 mm	970 mm
90° elbow		n/a	1000 mm
0.6 m flue terminal	600 mm	30 mm	570 mm
Total			4.510 mm

## 2.12 FITTING THE TURRET

1. Ensure the condensate trap in filled with water
2. Ensure the rubber seal is not damaged and fitted correctly on the appliance manifold.
3. Firmly hold the flue and push the turret on until it has travelled 30 mm ensuring the flue has not rotated or moved forward.
4. Push the turret into the manifold ensuring the upper plastic lip is flush with the top of the manifold.
5. Fully engage the clamp location section into the manifold location hole and rotate down onto the flange.
6. Use the securing screws to secure the clamp to the appliance.
7. Ensure all sample points are accessible and all sample plugs and caps are fitted.

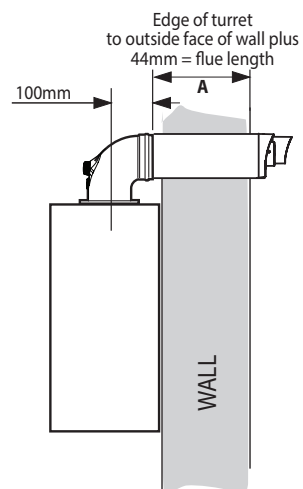
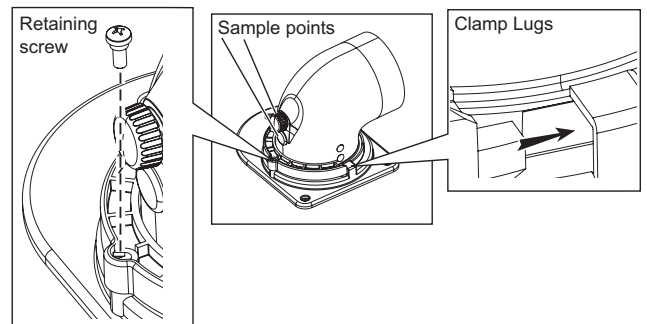
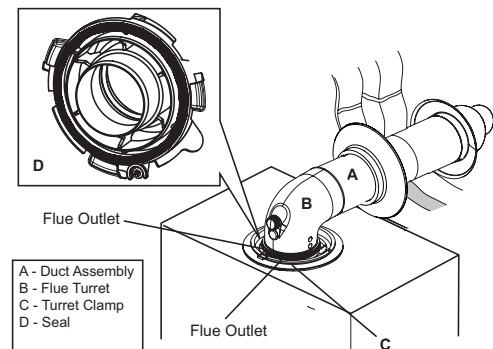

## 2.13 CUTTING THE FLUE

### CUTTING HORIZONTAL FLUE TERMINAL (non-telescopic)

1. Measure the required cut flue length ( $A + 44$  mm)
2. Measure from the outer terminal lip to the end of outer tube. Mark the required cut length ( $A + 44$  mm) around the circumference of the outer tube and cut following the mark to ensure it is cut square.
3. Mark and cut the inner tube 10 mm longer than the outer tube ensure the cut is square.
4. Remove all burrs on the inner and outer tube and place a light chamfer on the inner tube to aid with assembly.

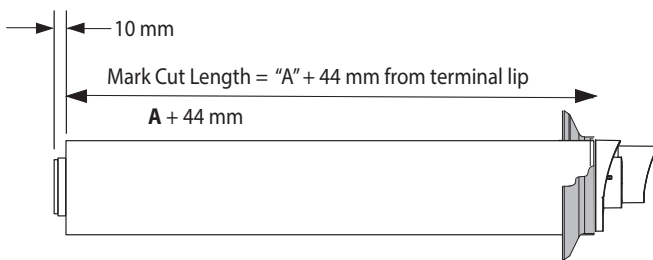

### SETTING TELESCOPIC FLUE

1. Measure the required length ( $A + 44$  mm)
2. Pull flue apart until the desired length is achieved ensuring the stop mark is not visible.
3. Ensure both flue seams are at the top and the flue outlet terminal is uppermost.
4. Drill a 3.5 mm hole through the small and large outer tube using the pilot hole on the large outer tube.
5. Secure large and small outer tube using the screws provided.
6. Seal the joint on the out tube with the tape provided.
7. Fit the internal and external wall seals.

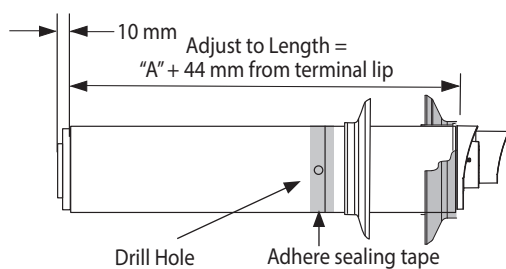

### FITTING THE FLUE THROUGH THE WALL (Internal Installation)

1. Measure the thickness of the wall.
2. To this measurement add 14 mm.
3. Make a mark on the flue shown as mark 1 below.
4. Make another mark on the flue a further 14 mm in shown as Mark 2 above right.
5. Fit the external wall seal (black) to the flue terminal ensuring it is fitted on the terminal outer lip seal.
6. Fit the inner wall seal approximately 65 mm prior to Mark 2.

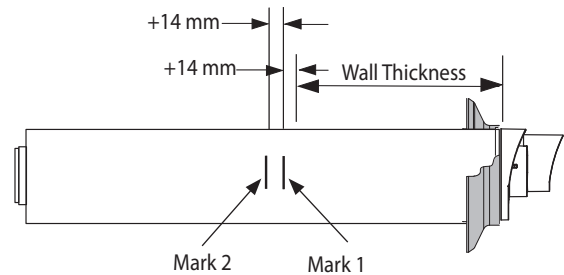

7. Place the terminal end of the flue into the 127 mm core drilled centrally and slowly apply slight pressure and move the flue up or down or side to side. This will cause the external wall seal to fold in and allow the flue to pass through the wall.
8. When the inner wall seal is flush against the wall pull back the flue until Mark 1 is flush with the inner wall surface.
9. Hold the flue steady and push the inner wall seal towards the wall until Mark 2 is just visible.

### FITTING THE FLUE THROUGH THE WALL (External Installation)

1. Follow steps 1 - 5 from above.
2. Push the flue through the 127 mm core drilled hole from the outside
3. Return inside the property and fit the inner wall seal to the flue.
4. Pull the flue internally until Mark 1 is flush with the inner wall surface.
5. Holding the flue in this position push the inner wall seal towards the wall until Mark 2 is just visible.

If Mark 1 is not flush with the inner wall surface and can be seen prior to the wall surface, then the external wall seal will have been dislodged and will require to be re-fitted. If this situation occurs, then please start the process from the beginning.

On completion the flue will be correctly installed as below.

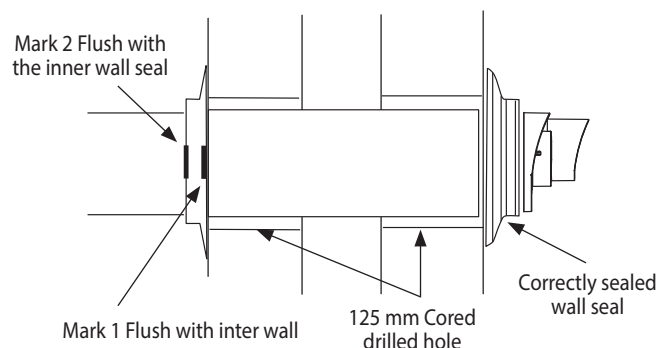

**IMPORTANT:** Ensure no White flue is visible between the flue terminal and the wall.

## Section 2 - Installation

A video showing how to correctly measure and fit a flue can be found by viewing the QR Code.

**SCAN**  
for Flue Fitting  
Video's



For the full range of FLUE ACCESSORIES please visit:  
<https://idealheating.com/logic-V4-literature-11>.

**SCAN**  
for Flues and  
Accessories Guide



### 2.14 ASSEMBLING THE VERTICAL FLUE

Determine the correct height that the flue should terminate above the roof. If after calculating or measuring the overall flue height from the top of the boiler, it is necessary to cut both pipes of assembly A, then ensure they are cut equally leaving the inner flue tube longer than the outer air tube as supplied.

Ensure the cut pipe ends are free from any burrs.

1. Position the roof flashing plate (supplied separately) over the hole cut in the roof and insert flue terminal from the roof end.
2. Fit the vertical connector (supplied in kit) in accordance with the instructions provided.
3. Secure the vertical connector by applying downward pressure on the connector.
4. Position the clamp on the top face of the flue manifold and push it horizontally backwards. Locate both clamp lugs into the flue manifold and secure to the flue manifold with the M5 retaining screw.

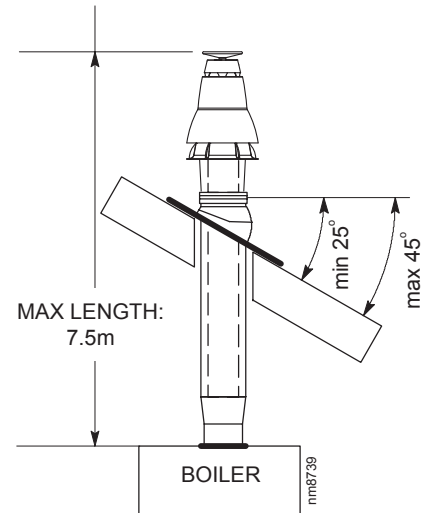

**Note.** Check the position of the inner flue duct relative to the outer duct on the assembled extension duct(s) and ensure the terminal flue duct is cut longer than the air duct to ensure engagement in the final flue duct seal.

7. Finally ensure the roof flashing plate is correctly sealed to the roof.

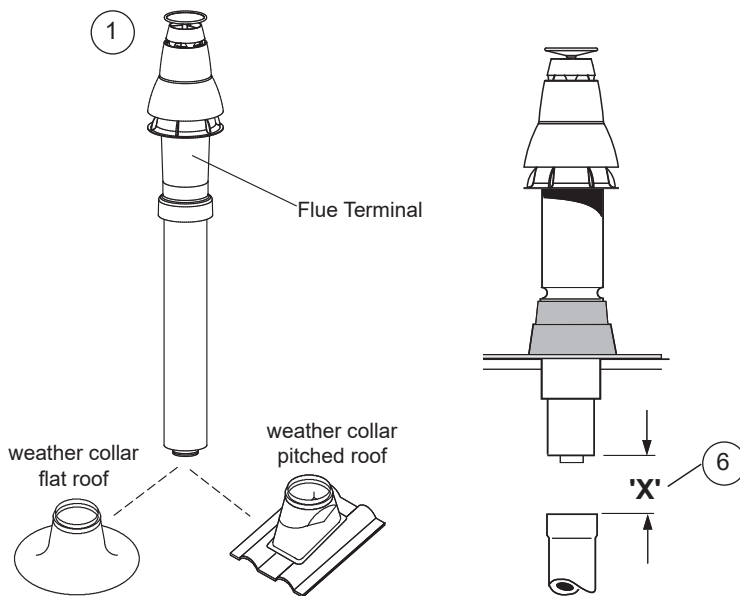

5. Push extension duct (if required (supplied separately)) into vertical connector.

**Note.** Ensure turret sample points are servicable and all caps and plugs are fitted. Fill the condensate trap/siphon with water.

6. If the last extension duct requires cutting, measure 'X', the distance (outer ducts), between the duct and the terminal and add 100 mm to this dimension. This gives the length of the last extension duct.

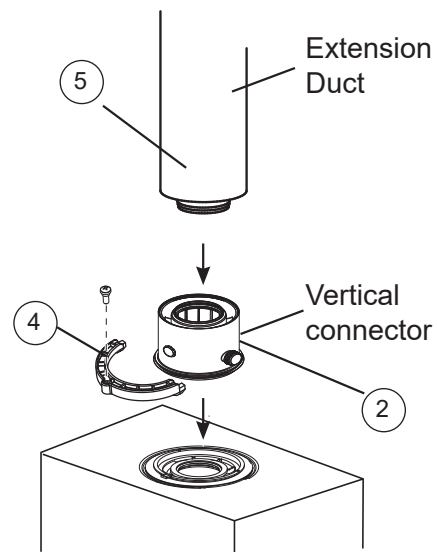

## 2.15 CONDENSATE DRAIN

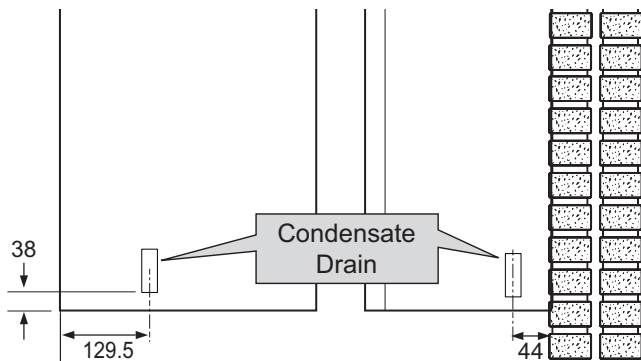

This appliance is fitted with a siphonic 75 mm condensate trap system that requires filling before operating the appliance for the 1st time or after maintenance.

All condensate pipework should conform to the following:

- Where a new or replacement boiler is being installed, access to an internal 'gravity discharge' termination should be one of the main factors considered in determining boiler location.
- Plastic with push fit or solvent connections.
- Internal plastic pipe work a minimum of 19 mm ID (typically 22 mm OD).
- External plastic pipe must be a minimum of 30 mm ID (typically 32 mm OD) before it passes through the sleeved wall.
- All horizontal pipe runs must fall a minimum of 52 mm per metre away from the Boiler.
- External & unheated pipework should be kept to a minimum and insulated with Class "O" waterproof pipe insulation through freezing or otherwise.
- All installations must be carried out in accordance to the relevant connection methods as shown in the "Condensate installation diagrams" & BS6798.
- Pipework must be installed so that it does not allow spillage into the dwelling in the event of a blockage (through freezing)
- All internal burrs should be removed from the pipe work and any fittings.

In order to minimise the risk of freezing, terminate the condensate drainage pipe using one of the following methods:

### Internal Drain Connections

Route the condensate pipe by gravity to an internal, foul water discharge point.

Refer to Fig.  
1 & 2

### Condensate Pump

When it is not practical to terminate the condensate pipe to an internal foul water discharge point using gravity, use a suitable pump recommended by the boiler or pump manufacturer.

Refer to Fig.  
3

### External Drain Connections

The use of an externally run condensate drainage pipe should only be considered after exhausting all internal termination options as described previously. An external system must terminate at a suitable foul water discharge point or purpose designed soakaway. If an external system is chosen then the following measures must be adopted:

The external pipe run should be kept to a minimum using the most direct and "most vertical" route possible to the discharge point, with no horizontal sections in which condensate might collect.

- For connections to an external soil/vent stack. Insulation measures as described should be used.

Refer to Fig.  
4

- When a rainwater downpipe is used, an air break must be installed between the condensate drainage pipe and the downpipe to avoid reverse flow of rainwater into the boiler should the downpipe become flooded or frozen.

Refer to Fig.  
5

- Where the condensate drain pipe terminates in a purpose designed soakaway (see BS 6798) any above ground condensate drain pipe sections should be run and insulated as described above.

Refer to Fig.  
6

- Where the condensate drain pipe terminates over an open foul drain or gully, the pipe should terminate below the grating level, but above water level, to minimise "wind chill" at the open end. The use of a drain cover (as used to prevent blockage by leaves) may offer further prevention from wind chill.

### Unheated Internal Areas

Internal condensate drain pipes run in unheated areas, e.g. lofts basements and garages, should be treated as external pipe.

Ensure the customer is aware of the effects created by a frozen condensate and is shown where this information can be found in the user manual.

**Note.** Please check current HHIC condensate discharge guidance available via the Gas Safe Registered Technical Bulletins List.

continued . . . . .

2.16 CONDENSATE DRAIN - CONT'D

**Figure 1** - Connection of Condensate Drainage Pipe to Internal Soil & Vent Stack

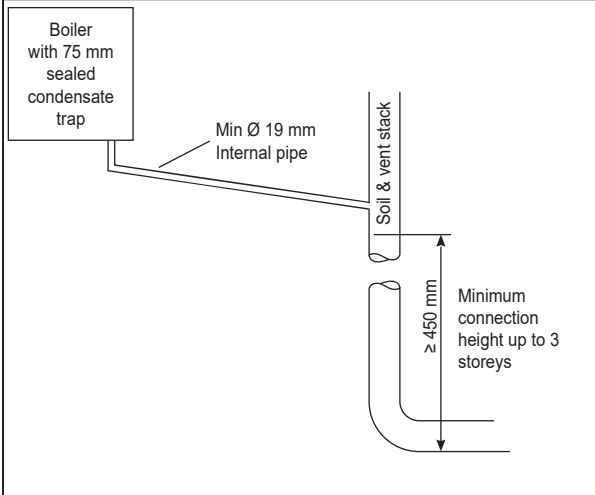

**Figure 2** - Connection of a Condensate Drainage Pipe Downstream of a Sink, Basin, Bath or Shower Water Trap to Internal Soil Vent Stack

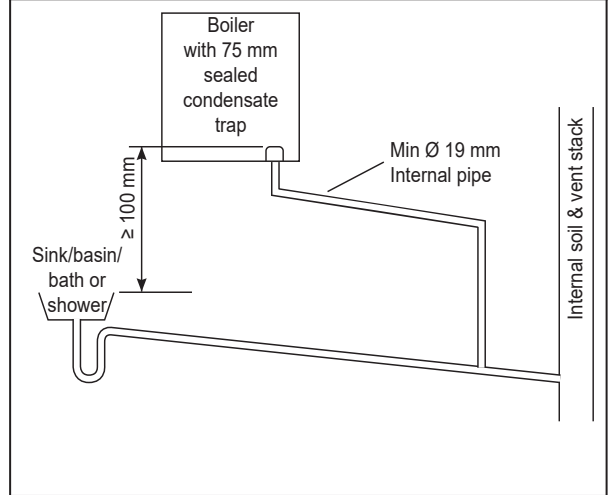

**Figure 3** - Connection of a Condensate Pump Typical Method (see manufacturer's detailed instructions)

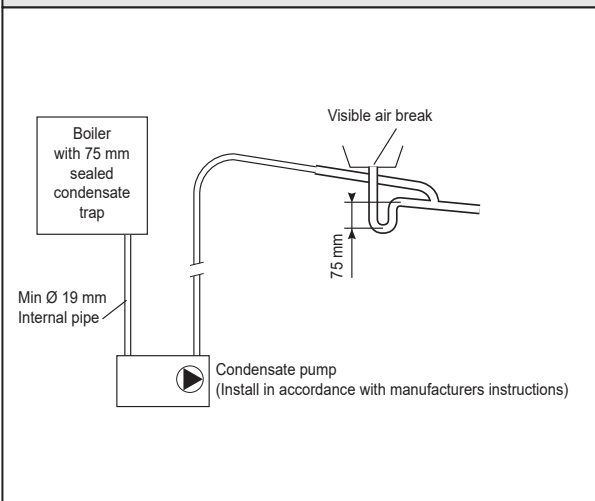

**Figure 4** - Connection of Condensate Drainage Pipe to External Soil & Vent Stack

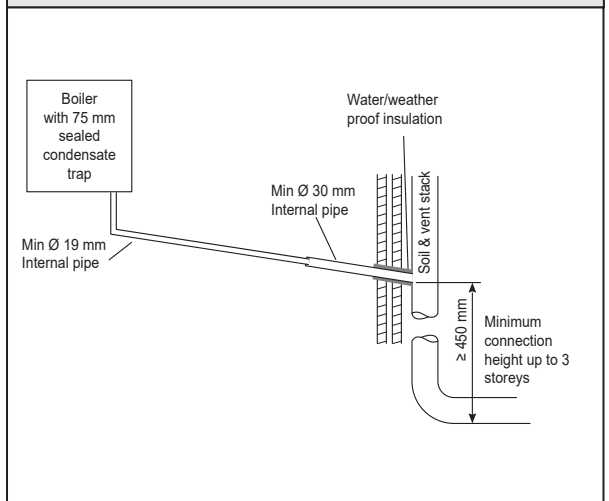

**Figure 5** - Connection of a Condensate Drainage Pipe to an External Rainwater Downpipe (only combined foul/rainwater drain)

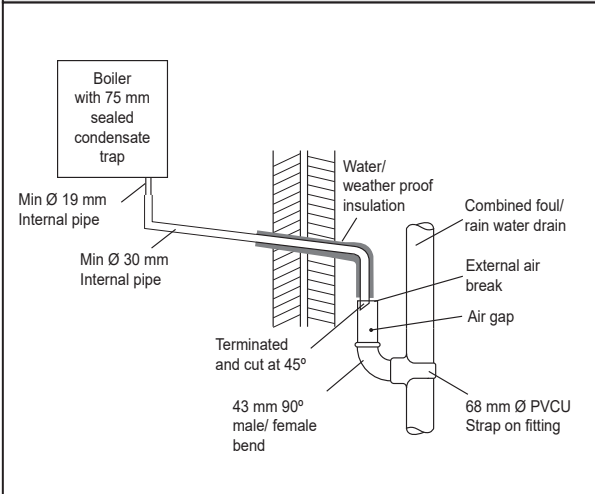

**Figure 6** - Connection of a Condensate Drainage Pipe to an External Purpose Made Soakaway.

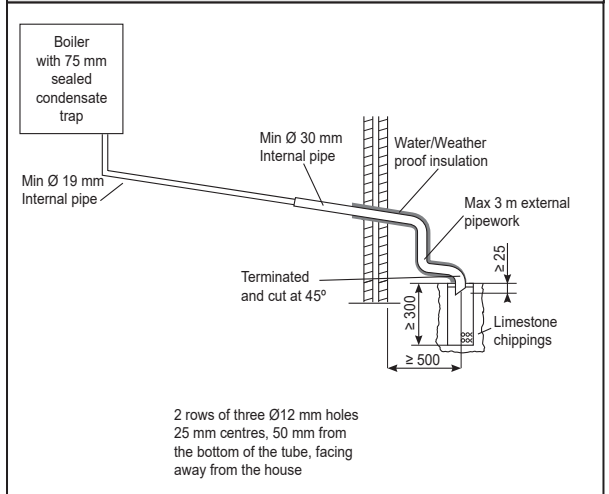

## 2.17 CONNECTIONS & FILLING

**CAUTION:** Heating the isolation valves may damage the fibre seals

Fit each union with the fibre seals provided.

### WATER CONNECTIONS CH

1. Connect the CH flow service valve (black handle) and copper tail provided in the hardware pack to the threaded boss connection provided at the lower rear of the boiler.
2. Connect the CH return valve (black handle) and copper tail.

### WATER CONNECTIONS DHW

1. Fit the DHW inlet service valve (blue handle) and copper tail to the threaded boss connection ensuring the seal provided is correctly located.
2. Fit the DHW outlet pipe tail to DHW outlet connection, ensuring the seal provided is correctly located.
3. Fit the filling loop provided between the DHW inlet valve and the CH return valve.

The domestic hot water flow rate is automatically regulated to a maximum:

kW	L/m	gpm
24	9.9	2.2
30	12.4	2.8
35	14.5	3.2

### GAS CONNECTION

**CAUTION:** The gas service cock is sealed with a non-metallic blue fibre washer, which must not be overheated when making capillary connections.

For details of the position of the gas connection:

Refer to Section 1.15

Refer to Gas Supply 1.10

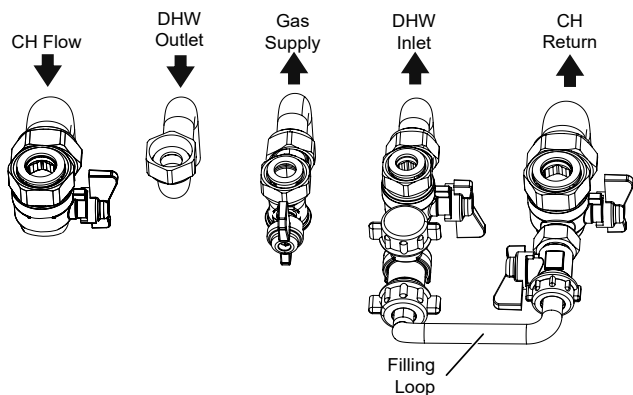

### PRV DRAIN

The PRV connection, located at the bottom right-hand side of the boiler comprises an open ended 15 mm pipe.

A 15mm compression coupling should be fitted to assist in removal of pipework if required.

**WARNING:** Make sure that the water or steam (from the boiler) is discharged safely. Hot water or steam is dangerous and can cause serious injury, and damage to electrical systems.

A purpose made PRV drain pipe is provided with the boiler to allow safe discharge through a wall to the outside of the building. This is particularly relevant to 'high rise' installations but can be used for all installations.

If a secondary PRV is required then the correct Logic2 Secondary PRV kit must be used and fitted correctly.

## 2.18 CONNECTIONS & FILLING CONTINUED

### FILLING

**WARNING:** Protect electrical connections from water

1. Connect the filling loop, ensuring the washers are in place.
2. Fully open the Pump Automatic Air Vent. If there is a leakage of water, then the Automatic Air Vent must be replaced.

Refer to Section 3.23

3. Check the following isolation handles on water connections are in the horizontal filling position (blue handle on DHW inlet (A) and black handle on CH return (C)).
4. Position the CH flow isolation valve handle in the vertical position to enable filling.
5. Slowly turn the filling loop handle (green (B)) to the horizontal open position until the pressure gauge reads between 1 to 1.5 bar.
6. Turn the filling loop handle (green (B)) back to the closed (vertical) position.
7. Turn the CH Return handle (black (C)) and the DHW Inlet handle (blue (A)) to the open (vertical) position.
8. Disconnect the filling loop from the DHW Inlet valve and fit the grey cap to the open end.
9. Fit the Plug to the free end of the filling loop.

### Top Up

1. Connect the filling loop, ensuring the washers are in place.
  2. Fully open the Pump Automatic Air Vent. If there is a leakage of water, then the Automatic Air Vent must be replaced.
- Refer to Section 3.23
3. Turn the DHW Inlet handle (blue (A)) to the horizontal position.
  4. Slowly turn the filling loop handle (green (B)) to the horizontal open position until the pressure gauge reads between 1 to 1.5 bar.
  5. Turn the handle (green (B)) on the filling loop back to the closed (vertical) position.
  6. Turn the DHW Inlet handle (blue (A)) to the open (vertical) position.
  7. Disconnect the filling loop from the DHW Inlet valve and fit the grey cap to the open end.
  8. Fit the Plug to the free end of the filling loop.

SCAN for video



Filling System Positions shown

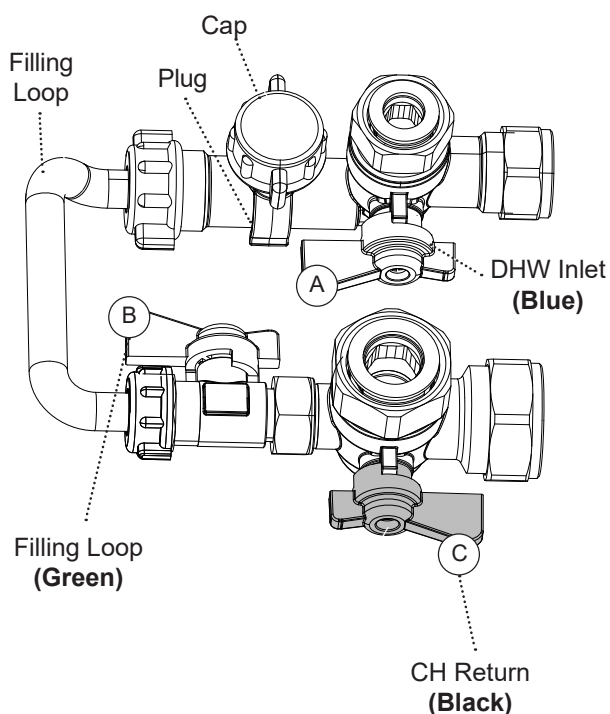

Top Up Pressure Positions shown

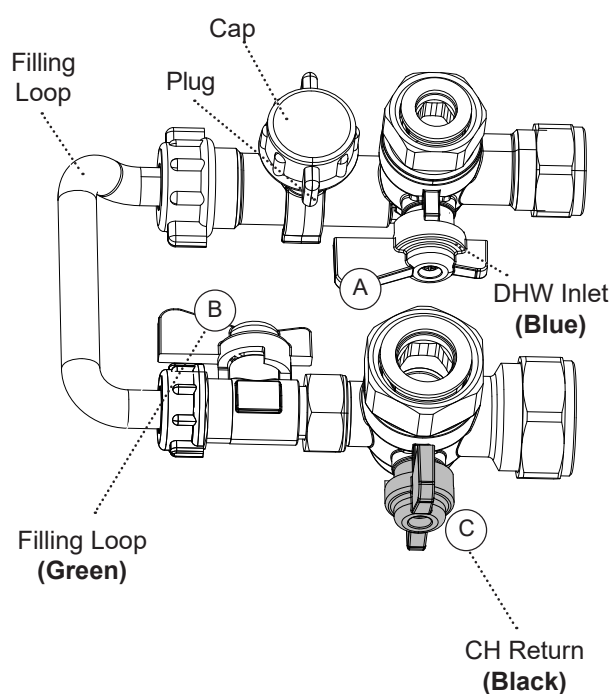

## 2.19 ELECTRICAL CONNECTIONS

**WARNING:** This appliance must be earthed

A mains supply of 230 V ~ 50 Hz is required.

3 A fuse required. All external controls and wiring must be suitable for mains voltage.

Wiring external to the boiler must follow current IET (BS7671) wiring regulations and local regulations.

Wiring should be 3 core PVC insulated cable, not less than 0.75 mm<sup>2</sup> (24 x 0.2 mm), and to BS EN 50525-1:2011 Table 16.

Connection must be made in a way that allows complete isolation of the electrical supply. The means of isolation must be accessible to the user after installation.

## 2.20 INSTALLER WIRING

**WARNING:** Ensure the supply cord is not damaged

The boiler must be connected to a permanent live power supply.

### Accessing the installer wiring

1. Isolate the mains supply from the boiler.
2. Remove the front panel.

Refer to Section 3.4

3. Swing down the control box into the service position, unclip and swing back the installer wiring cover and latch into the retaining clips.

4. Carefully pierce the grommet, release the cable clamp via the screws and pull wiring through.
5. Connect external wiring to the appropriate connections securely and then refit the cable clamp.

Once any wiring is completed, to secure the boiler, reverse the order above.

The link wire on the 230 V installer room stat/timer connection gives a demand in conjunction with the timer option plug inside the timer option cover. This is located on the front of the control box.

Installer Connections (LHS)

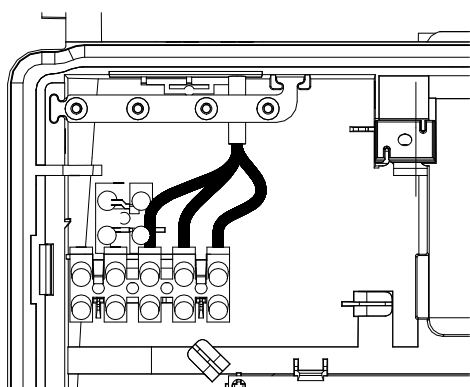

Installer Connections (RHS)

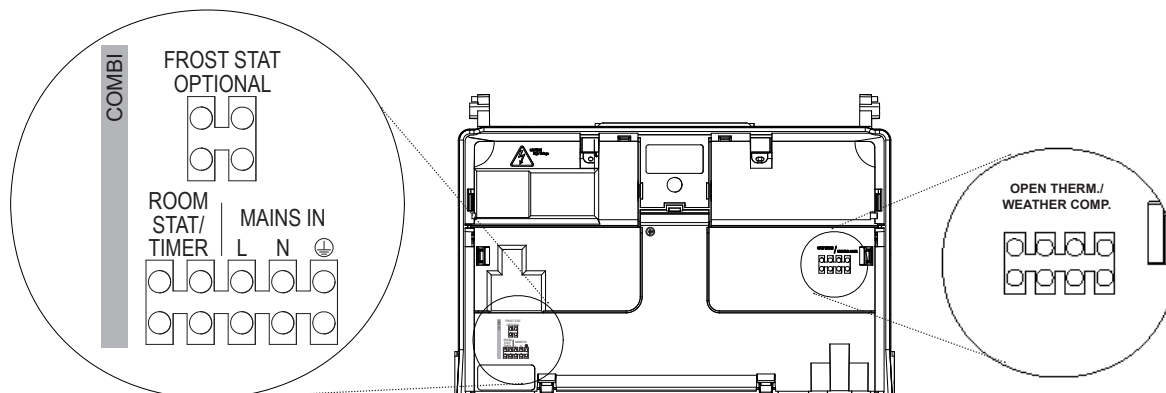
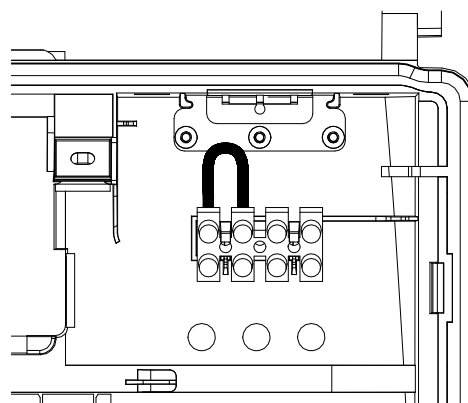

## 2.21 EXTERNAL WIRING

### External Controls – 230 V 50 Hz

Wiring a 230V Programmable Room Stat (Diagrams A & C) or 230V Timer & Room Stat (Diagram B).

1. Remove the link wire from the room stat/timer connection.
2. Connect the external cable from the room stat/timer across this connection. If a general live connection is used for the room stat or timer then connect this to the fused spur, on the load side (see Diagram C).
3. If the room thermostat has compensation and requires a neutral connection, make this connection to the fused spur, on the load side.

### Optional External Controls – Extra Low Voltage

Wiring Open Therm Programmable Room Stat (Diagram D).

1. Make sure that the link wire is connected to the room stat/timer connection.
2. Make sure that the OpenTherm link (8-way connector) is connected in the aperture, located on the front of the boiler.
3. Remove the link wire from the OpenTherm installer connection, located on the RHS of the control box.
4. Connect the external cable from the OpenTherm device to the OpenTherm installer connection.

### Frost Protection

If parts of the pipework run outside the house or if the boiler will be left off for more than a day or so then a frost thermostat should be wired into the system.

This is usually done at the programmer, in which case the programmer selector switches are set to OFF and all the other controls MUST be left in the running position.

The frost thermostat should be sited in a cold place, but where it can sense heat from the system.

Wiring a system frost thermostat, see diagrams E. Wire the frost thermostat across the two connections as shown.

If the boiler is installed in a garage it may be necessary to fit a pipe thermostat, preferably on the return pipework.

**Diagram A: 230 V Programmable Room Stat**

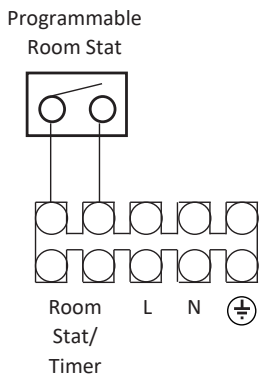

**Diagram B: 230 V Timer & Room Stat**

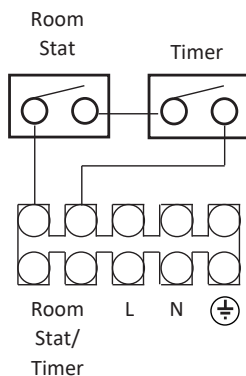

**Diagram C: 230 V Programmable Room Stat Use of Live from Isolator**

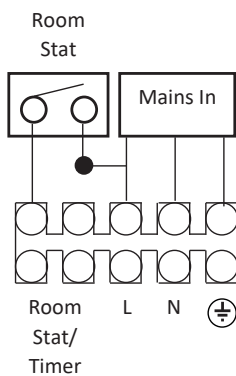

**Diagram D: OpenTherm Programmable Room Stat**

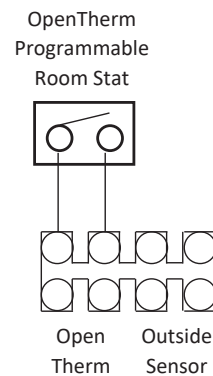

**Diagram E: 230 V Optional Frost Stat**

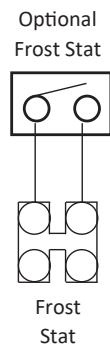

2.22 WIRING DIAGRAM

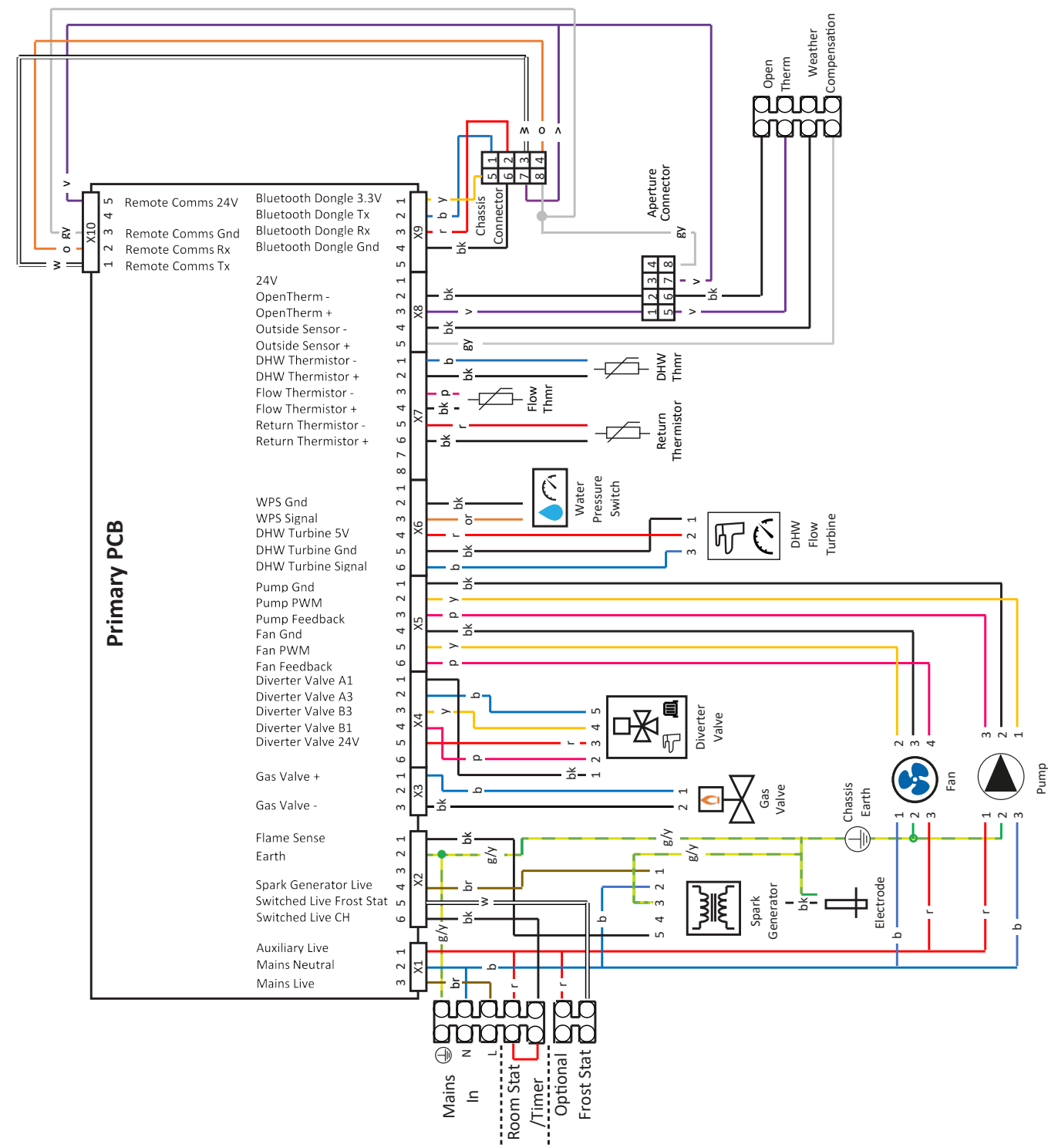

- Key**
- bk: Black
  - gy: Grey
  - r: Red
  - g: green
  - b: blue
  - br: brown
  - g/y: green/yellow
  - o: orange
  - p: pink
  - v: violet
  - y: yellow
  - w: white

## 2.23 REPLACING PRE-FITTED MAINS CABLE

If it is necessary to use an alternative mains cable to the one pre-fitted then use the following guide.

Replacement wiring should comply with notes and be carried out by a qualified person.

Refer to Section  
2.19 & 2.20

1. Isolate the mains supply to the boiler.
2. Remove the front panel.
3. Swing the control box down into the service position, unclip and swing back the installer wiring cover to latch into the retaining clips.
4. Unscrew the L N & E connections & remove wires from connector.
5. Remove the mains cable by pulling back through the grommet.
6. Route the replacement through the grommet and re-fit.
7. Close the installer wiring cover ensuring that it is located correctly and that the cable is retained into the strain relief as shown.

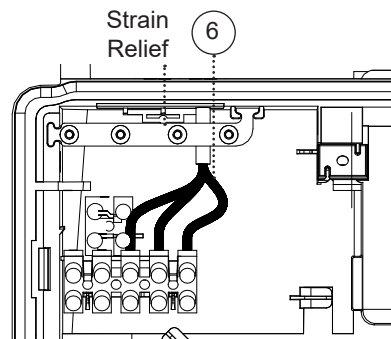

8. Swing the control box back up into the operating position and re-fit the front panel ensuring a good seal is made.

The earth connection should be longer than the current carrying connections. If the cord anchorage slips, the current carrying wires become taut before the earth.

## 2.24 COMMISSIONING AND TESTING

### A. Electrical Installation

**WARNING:** Electrical safety checks should be carried out by a qualified person.

Complete preliminary electrical system checks.

#### General

The combustion for this appliance has been checked, adjusted and preset at the factory for operation on the gas type defined on the appliance data plate.

Do not adjust the air / gas ratio valve.

Check the following:

1. The boiler has been installed in accordance with these instructions.
2. The integrity of the flue system and the flue seals, as described in the Flue Installation Section.

Proceed to put the boiler into operation as follows:

1. Check the operational gas inlet pressure.
2. Set up the boiler to operate at maximum rate by opening hot tap to maximum flow.
3. With the boiler operating in the maximum rate condition check that the operational gas pressure at the inlet gas pressure test point complies with the requirements.
4. Ensure that this inlet pressure can be obtained with all other gas appliances in the property working.

Refer to Gas Supply  
page 10

### Intelligent Load Optimisation

Intelligent Load Optimisation is a feature enabled on the boiler to reduce cycling on and off and behaves as follows.

With an active CH demand (e.g. Switched Live on), if the Flow Temperature reaches the CH Target + 4°C then the boiler switches off and the Intelligent Load Optimisation function is activated. This can happen if the system load is less than the minimum output of the boiler.

If the CH demand is still active, when the boiler lights again it immediately modulates down to the minimum rate over 60s and then stays at the minimum for 10 minutes.

Normal operation resumes after either of the following conditions are met:

- After 10 minutes of operation at minimum rate.
- The CH demand is off for more than 1 hour.

**IMPORTANT:** A condition of the manufacturer's warranty is that Benchmark commissioning process is completed. The flow chart is provided on page 68.

### B. Gas Installation

**WARNING:** Open windows, doors and extinguish flames before starting the next steps. Do not smoke.

1. The whole of the gas installation, including the meter, should be inspected and tested for tightness and purged in accordance with the recommendations of BS.6891.
2. Purge air from the gas installation by the approved methods only.

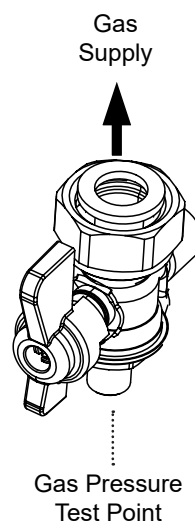

## 2.25 INITIAL LIGHTING

### Legend

- A. Domestic Hot Water Temperature Knob
- B. Central Heating Temperature Knob
- C. Mode Button
- D. Boiler Status Display
- E. Burner On indicator
- F. Restart Button
- G. CH Flow Isolating Valve
- H. Gas Inlet Pressure Test point
- I. Gas Service cock
- J. DHW Inlet Valve
- K. CH Return isolating valve
- L. DHW Outlet
- M. Filling loop valve
- N. Pressure Gauge

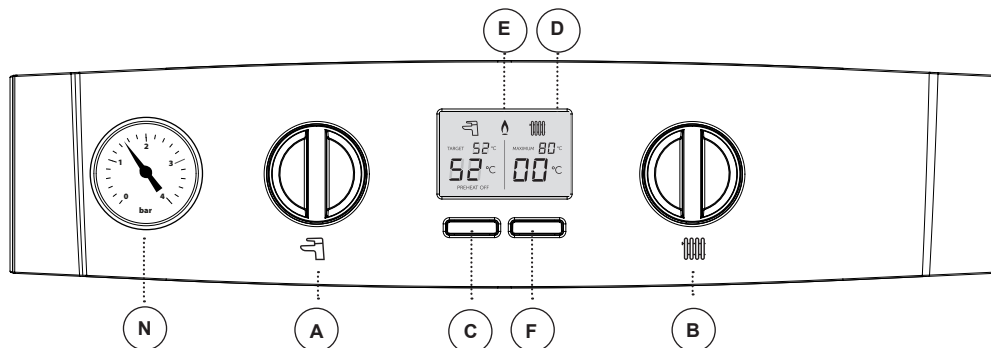

**CAUTION:** Do not operate the appliance before it has been fully vented of air. If it is necessary to operate the pump, do so with the gas service cock turned off.

The boiler incorporates a fan overrun cycle which must not be interrupted by isolation of electricity supply.

1. Check that the system has been filled and that the boiler is not airlocked.
2. Refit the boiler front panel.
 

Refer to Section 3.4
3. Check that the drain cock is closed and that the CH and DHW isolating valves (G,K & J) are OPEN.
4. Press the Mode button until a cross is shown going through both tap and radiator icons (boiler off)
5. Switch the electrical supply OFF
6. Check that the gas service cock (I) is OPEN.
7. Slacken the screw in the inlet pressure test point (H) and connect a gas pressure gauge via a flexible tube.
8. Switch the electricity supply ON and check all external controls are calling for heat.

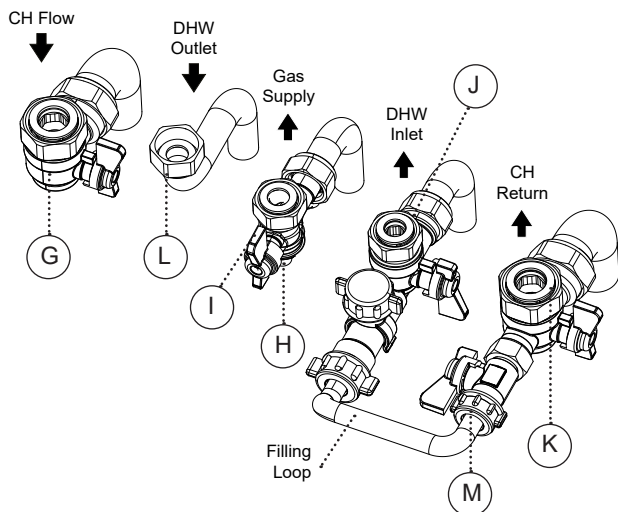

### CENTRAL HEATING

9. Press the Mode Button (C) until there is no longer a cross through the Radiator icon. Turn the Central Heating Temperature Knob clockwise until a target of 80°C is shown. The boiler control will now go through its ignition sequence until the burner is established.
10. If the boiler does not light then after 5 attempts the boiler will lock out and display fault code L2. Press the Restart Button (F). The boiler will repeat its ignition sequence. If Restart occurs 5 times within 15 minutes then L 0C will be shown.

When the burner is established the flame symbol (E) will be shown on the display and the current flow temperature will be shown in the large digits underneath the radiator symbol.

### DOMESTIC HOT WATER

11. With the boiler firing, rotate the DHW Temp Knob (A) clockwise until a target of 65°C is shown and fully open a DHW tap. The boiler should continue to run and the current DHW temperature will be shown in the large digits underneath the tap symbol.
12. Ensure that with the boiler operating, the dynamic gas pressure is able to obtain maximum output.

Refer to Table 3

### IMPORTANT

The gas input to the burner is regulated by the gas valve according to the air flow produced by the fan. It is not user-adjustable. Any interference to sealed settings on the gas valve will adversely affect operation and render our warranty void.

Refer to Gas Supply page 10

13. Turn off the DHW tap.
14. Remove gas pressure gauge, tighten inlet pressure test point and check for gas tightness.

## 2.26 THE DISPLAY

The user control has one display to inform the user about the status of the boiler. The display shows the status of the flame. If no flame is detected then flame symbol will not be visible. When the flame is detected the flame symbol will be visible permanently.

Below is a list with display function.

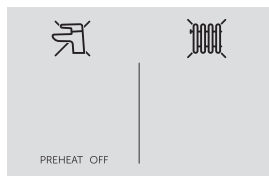

### Boiler Off Mode

Press the Mode button once to enable DHW or twice to enable CH.

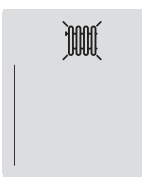

### CH Off

Press the Mode button until the cross disappears to enable CH.

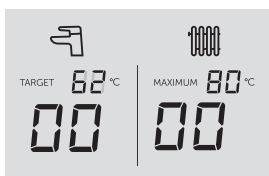

### Winter Mode, no heat demand



### Boiler is active for Central Heating

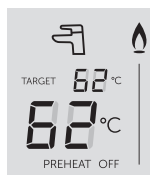

### Boiler is active for Domestic Hot Water

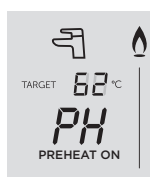

### Boiler is heating up the Plate Heat Exchanger



**Boiler is active for boiler frost protection:** operates if the ambient temperature is below 5°C until it reaches 19°C.

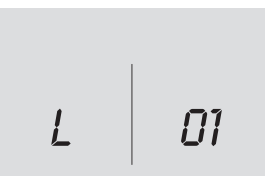

**Boiler is in Lockout for a specific error.** Display will show a number after the "L" to indicate which error is detected

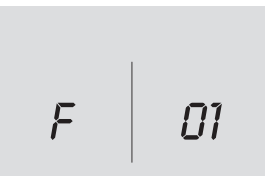

**Boiler has a fault for a specific error.** Display will show a number after the "F" to indicate which error is detected.

## 2.27 GENERAL CHECKS

**Make the following checks for correct operation in:**

1. Fully open all DHW taps in turn and ensure that water flows freely from them.

The display should show



2. Close all taps except the furthest one from the boiler and check that the boiler is firing at maximum rate. This is factory set to give a DHW temperature rise of approximately 35°C at the flow rate stated on page 10 under 'operation'.

3. Reduce the DHW draw-off rate to about 3 l/min (0.7gpm) and check that the boiler modulates to deliver DHW at approximately 65°C.

4. Close the DHW tap and check that the main burner extinguishes. The pump should overrun for 60 seconds. When the pump stops the display should show:



**Note.** On systems in excess of 2 bar inlet pressure a water pressure governor may be required to prevent water noise.

### CENTRAL HEATING (CH) & DOMESTIC HOT WATER (DHW) MODE.

1. Ensure that the CH external controls are calling for heat.

The display should show:

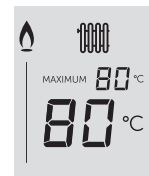

2. Fully open a DHW tap and check that hot water is delivered.

The display should show



3. **Gas Rate**

Check the boiler gas rate when the boiler is at full DHW output.

Check at the gas meter, with no other appliance in use. Refer to Tables 2 & 3 for gas rates.

4. Close the DHW tap.

5. Set the central heating external controls to OFF. The burner should go off and the pump continue to run for two minutes.

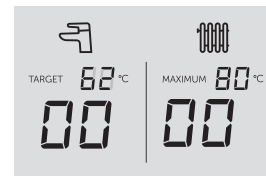

The display should show:

6. Check the correct operation of the timer (if fitted) and all other system controls. Operate each control separately and check that the main burner responds.

## 2.28 GENERAL CHECKS - WATER CIRCULATION

### WATER CIRCULATION SYSTEM

1. With the system COLD, check that the initial pressure is correct to the system design requirements.

For pre-pressurised systems, this should be 1.0 bar.

2. With the system HOT, examine all water connections for soundness. The system pressure will increase with temperature rise but should not exceed 2.5 bar.

3. With the system still hot, turn off the gas, water and electricity supplies to the boiler and drain down to complete the flushing process.

**Note.** A flushing solution should be used during the flushing procedure. Flushing solutions: Fernox Superfloc, Sentinel X300 (new systems) or X400 (existing systems).

Refer to Section  
1.19

4. Refill and vent the system, add inhibitor (Refer to section 1.17), clear all air locks and again check for water soundness.

5. Reset the system initial pressure to the design requirement.

6. Balance the system.

Refer to Section  
1.18

7. Check the condensate drain for leaks and check that it is discharging correctly.

8. Finally, set the controls to the User's requirements.

**Note** The pump will operate briefly as a self-check once every 24 hours in the absence of any system demand.

### WATER TEMPERATURES

Temperatures can be selected using the CH and DHW thermostats.

Temperature Knob Setting	CH Flow Temp °C	DHW Outlet °C
Max	80	65
Min	30	40

Due to system variations and seasonal temperature fluctuations DHW flow rates/temperature rise will vary, requiring adjustment at the draw off tap : the lower the rate the higher the temperature, and vice versa.

## 2.29 RESTART PROCEDURE

### Legend

- A. Domestic Hot Water Temperature Knob
- B. Central Heating Temperature Knob
- C. Mode Button
- D. Boiler Status Display
- E. Burner On indicator
- F. Restart Button

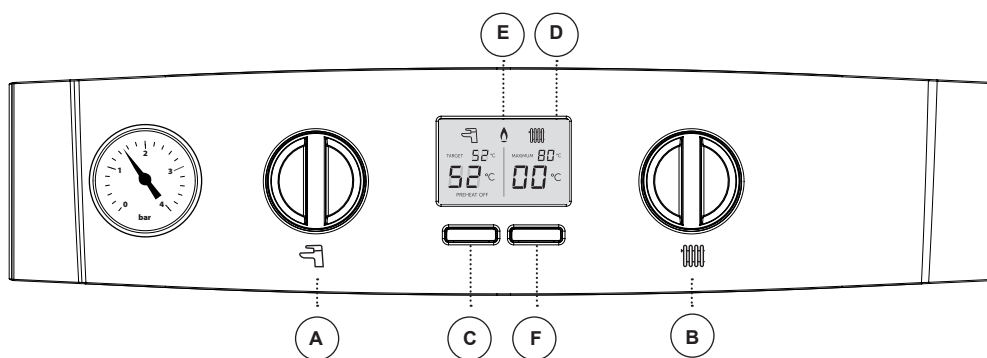

If an L code is shown on the display then the boiler can be restarted by pressing the Restart button (F).

## 2.30 ACCESSING THE INSTALLER MODE

To access Installer Mode, press the "MODE" and "RESTART" buttons together for more than 5s.

1. The last 3 faults will be shown. See *Section 4.1* for Fault Code descriptions.

2. "PH" will be shown.

To change the preheat setting press Restart, press Mode, then press Restart again, otherwise press Mode.

### Timed Preheat Function

If Preheat is switched On, then preheating will occur at the same times that hot water demands occurred on the previous day.

E.g. If you have a shower at 6am on a Monday, then the boiler will automatically preheat the water for your shower for 6am on a Tuesday.

Consequently the function becomes active 24 hours after it is switched on. This function is designed to maximise comfort, whilst minimising energy consumption.

3. "SH" will be shown.

To run the burner at maximum rate press "RESTART", otherwise press "MODE".

4. "SL" will be shown.

To run the burner at minimum rate press "RESTART", otherwise press "MODE". Note that if the return temperature is less than 40°C then the burner will run at maximum rate

for 30s before ramping down to minimum rate over 60s and then running at minimum rate for 10 minutes. If the return temperature is more than 40°C the burner will immediately ramp down to minimum rate over 60s and then run at minimum rate for 10 minutes.

5. "UF" will be shown.

To activate the Venting function press "RESTART", otherwise press "MODE". The Venting function runs for 5 minutes before automatically returning to normal operation. The diverter valve moves between CH and DHW every 30s. The pump alternates between being on for 50s and then off for 10s.

6. "DL" will be shown.

To move the diverter valve to mid-position for replacement press "RESTART", otherwise press "MODE".

7. "P" will be shown.

To set the minimum CH pump speed to 100% press "RESTART", otherwise press "MODE".

8. "P7" will be shown.

To set the minimum CH pump speed to 70% press "RESTART", otherwise press "MODE".

9. "SE" will be shown.

For service timer function refer to separate instructions. Press "MODE" to exit.

## 2.31 HANDING OVER

**After completing the installation and commissioning of the system the installer should hand over to the householder by the following actions:**

1. Hand the Instructions to the householder and explain his/her responsibilities under the relevant national regulations.
2. Explain and demonstrate the lighting and shutting down procedures.
3. The operation of the boiler and the use and adjustment of all system controls should be fully explained to the householder, to ensure the greatest possible fuel economy consistent with the householder requirements of both heating and hot water consumption. Advise the user of the precautions necessary to prevent damage to the system and to the building. In the event of the system remaining inoperative during frosty conditions.
4. Explain the function and the use of the boiler heating and domestic hot water controls. Explain that due to system variations and seasonal temperature fluctuations DHW flow rates/temperature rise will vary, requiring adjustment at the draw off tap. It is therefore necessary to draw the user's attention to the section in the Users Instructions titled "Control of Water Temperature" and the following statement.  
**"Additionally, the temperatures can be controlled by the user via the draw-off tap: the lower the rate the higher the temperature and vice versa."**
5. Explain the function of the boiler fault mode. Emphasise that if a fault is indicated refer to "Fault Codes" in the User Guide.
6. Explain and demonstrate the function of timers and temperature controls, radiator valves etc. for the economic use of the system.

7. Loss of system water pressure.

Explain that the dial on the control panel front indicates the central heating system pressure and that if the normal COLD pressure of the system is seen to decrease over a period of time then a water leak is indicated. Explain the re-pressurising procedure and if unable to re-pressurise or if the pressure continues to drop a registered local heating installer should be consulted.

Refer to Section  
2.18

8. Explain boiler restart procedure.

Refer to Section  
2.29

9. After installation and commissioning please complete the Commissioning Checklist before handover to the customer.



Refer to  
Page 66

### ! IMPORTANT

10. A comprehensive service should be carried out annually. Stress the importance of regular servicing by a Gas Safe Registered Engineer.
11. Inform the householder of the guarantee/registration found within the envelope pack and then requirement to register it to receive the full benefit of the warranty.

## 3.1 SERVICING SCHEDULE



**WARNING:** Servicing can only be carried out by Gas Safe Registered Engineers  
 Always turn OFF the gas supply at the gas service cock, and switch OFF and disconnect the electricity supply to the appliance before servicing  
**Combustion testing must be carried out by a competent person using a combustion analyser conforming to BS EN 50379-3:2012.**

To ensure the continued safe and efficient operation of the appliance it is recommended that it is checked at regular intervals and serviced as necessary. The frequency of servicing will depend upon the installation condition and usage but should be carried out at least annually.

For the latest copy of literature, visit our website [idealheating.com](http://idealheating.com).

### PRELIMINARY INSPECTION

1. Light the boiler and carry out a pre-service check, refer to the fault finding chart.
2. Check the flue terminal (and terminal guard if fitted) for damage and obstruction.
3. Check combustion by connecting the flue gas analyser to the flue gas sampling point as shown in the diagram and measure CO and CO<sub>2</sub> at maximum rate. Set the boiler to Maximum and Minimum heat inputs.

Refer to Page  
68

If the CO / CO<sub>2</sub> ratio is greater than 0.004 please proceed to "Cleaning Procedure".

If the CO / CO<sub>2</sub> ratio is less than 0.004 please proceed to "Check Procedure".

### CHECK PROCEDURE

1. Check all water and gas joints for signs of leakage. Remake any suspect joints ensuring a gas tightness check is carried out if applicable and the water system is correctly refilled, vented and re-pressurised.
2. Proceed to "IMPORTANT".

### IMPORTANT

1. If, for any reason, the condensate trap has been removed, ensure the trap is refilled with water before re-assembling.
2. After completing the servicing or exchange of components always ensure all gas valve connections are gas tight with a gas soundness check up to the gas control valve.
3. When work is complete the front panel MUST be correctly refitted, ensuring that a good seal is made.
4. Clean the system filter (if fitted).
5. Complete the service section in the Benchmark Commissioning Checklist.

### GENERAL

During Servicing, and after any maintenance or change of part of the combustion circuit, the following must be checked:

- The integrity of the flue system and the flue seals.
- The integrity of the boiler combustion circuit and the relevant seals.
- The operational (working) gas inlet pressure at maximum rate.
- The gas rate.
- The combustion performance.

### CLEANING PROCEDURE

1. Remove the casing.
2. Visually check the appliance for signs of leakage.
3. Remove the flue manifold.
4. Remove the fan.
5. Remove the burner.
6. Refit the sump outlet cover.
7. Clean the heat exchanger by pouring warm water across the whole heat engine to flush deposits taking care to avoid pouring water over the electrode.
8. Check the electrode for damage and clean using an abrasive cloth. Check and adjust the spark gap. Replace the electrode if damaged.
9. Clean out the sump outlet to ensure any debris is removed.
10. Remove and clean the condensate trap and re- prime the trap before re-installing.
11. Check the DHW filter for blockage.
12. Re-assemble the components in reverse order.
13. Clean the system filter (if fitted).
14. Carry out post service checks on the combustion circuit. See General below.
15. Check the system water quality in accordance with BS7593:2019.
16. Complete the service record in the Benchmark section.

**Do not operate the boiler if the front panel is not fitted.**

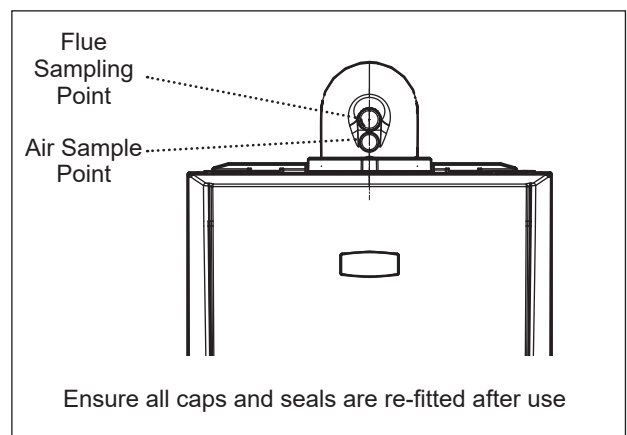

## 3.2 REMOVAL / REPLACEMENT OF COMPONENTS

**WARNING:** Do not operate the boiler without a front panel fitted

### When replacing any component.

1. Isolate the electricity supply.
2. Turn off the gas supply.
3. Remove the boiler front panel.

Refer to Section  
3.4

4. Swing the control box down into its servicing position.

### After removing / replacing any component.

5. Ensure all gas valve connections are gas tight with a gas soundness check up to the gas control valve.
6. Ensure all water connections are tight.
7. Test the appliance for correct and safe operation.

Refer to Section  
3.1 (General)

### Notes.

1. In order to assist fault finding, the control panel has an LCD diagnostic display. The key to boiler fault conditions is shown in Section 4.
2. In order to replace components in Sections 3.11, 3.14 and 3.20-3.31, it is necessary to drain the boiler.

## 3.3 DRAINING THE BOILER

Refer to Section  
3.4

### CENTRAL HEATING CIRCUIT

1. Close all the CH water isolating valves on both the flow and return.
2. To drain the primary heat exchanger circuit: Open the drain valve and attach a length of hose to the CH drain point.
3. After replacing any component on the boiler, remove the hose, close the drain valve and open all system isolating valves.
4. Repressurise by reconnecting the filling loop, check for leaks before proceeding to check operation of the boiler.

Refer to Section  
2.18

5. Disconnect filling loop.

### DOMESTIC HOT WATER CIRCUIT

1. Close all the DHW water isolating valves on the boiler inlet.
2. To drain the domestic hot water circuit: As there is no direct drain for the domestic hot water circuit, depending on the location of the boiler, opening the lowest hot water tap may drain this circuit. However it must be noted that some residual water will be released during replacement of components.
3. After replacing any component on the boiler, open isolating valve.

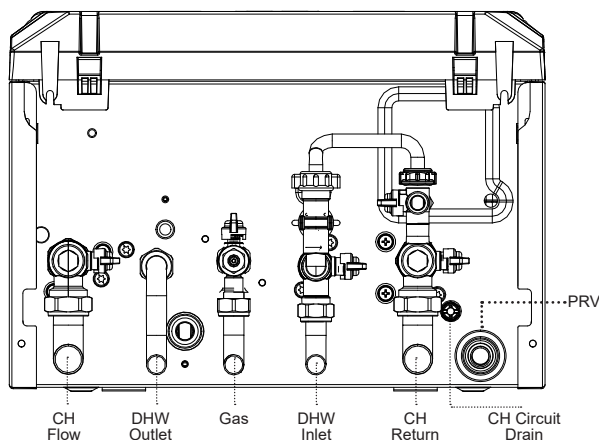

## 3.4 BOILER FRONT PANEL REMOVAL / REPLACEMENT

### REMOVAL

1. Loosen the two screws retaining the front panel.
2. Pull the two clips down to disengage and pull panel forward and upward and remove.

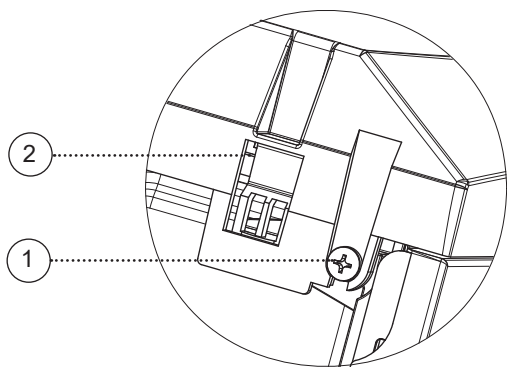

View from bottom of boiler

### REPLACEMENT

3. Hook the panel onto the top retaining clips.
4. Push the panel until the 2 bottom spring clips engage ensuring the 2 knobs and 2 buttons line up with the holes in the front panel.
5. Re-tighten the two retaining screws.

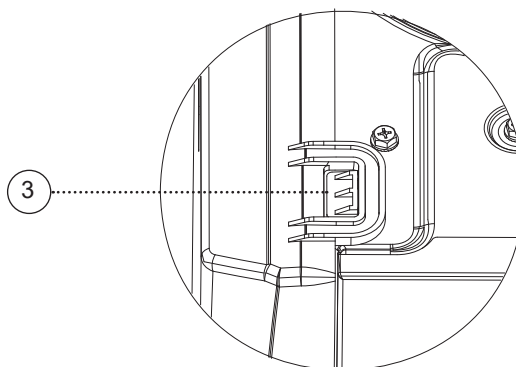

View from top of boiler

## 3.5 FLUE MANIFOLD REMOVAL/REPLACEMENT

1. Remove the two sump cover retaining screws.
2. Remove the sump cover.
3. Lift the manifold upwards to clear the sump.
4. Move the manifold to the left and pull down to remove.

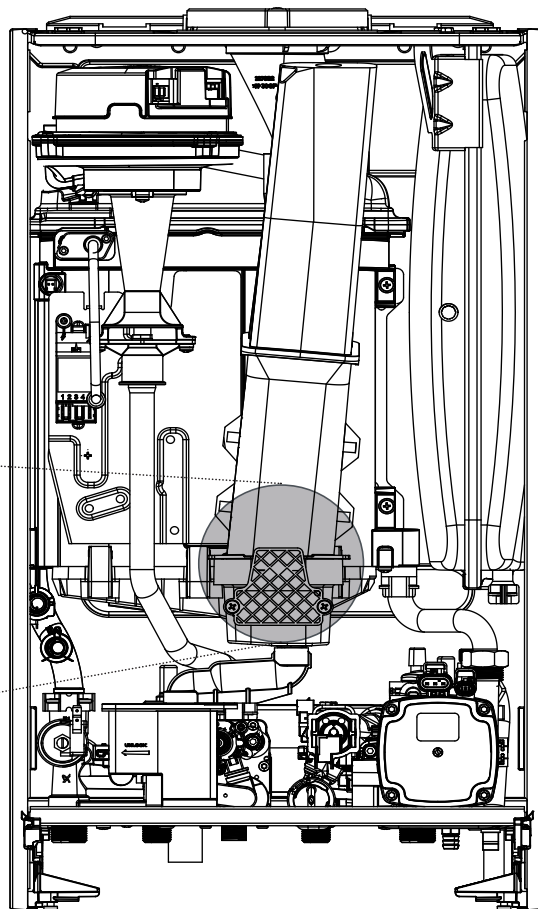
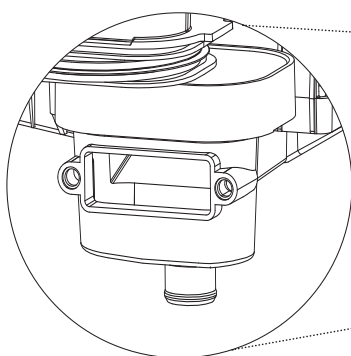

## 3.6 FAN AND VENTURI ASSEMBLY REMOVAL AND CLEANING

1. Disconnect the electrical leads from the fan.
2. Remove the clip from the gas control valve outlet and ease the pipe upwards. Rotate and then ease down to remove.
3. Remove the extended nut on the fan mounting bracket.
4. Lift off fan and venturi assembly.
5. Undo the two M4 screws and release the nozzle assembly.
6. Inspect the injector for blockage or damage.
7. Clean the outside of the injector and use a small flue brush to clean the injector hole. Do not use anything abrasive such as a file.
8. Remove the screw and twist venturi anti-clockwise to remove venturi assembly, noting the orientation of the venturi in relation to the fan body.
9. Inspect fan outlet sealing gasket and replace if necessary.
10. Ensure the venturi is free from dust/debris.
11. Check the 'O'-rings are fitted correctly to the gas outlet pipe replacing if any damage is witnessed.

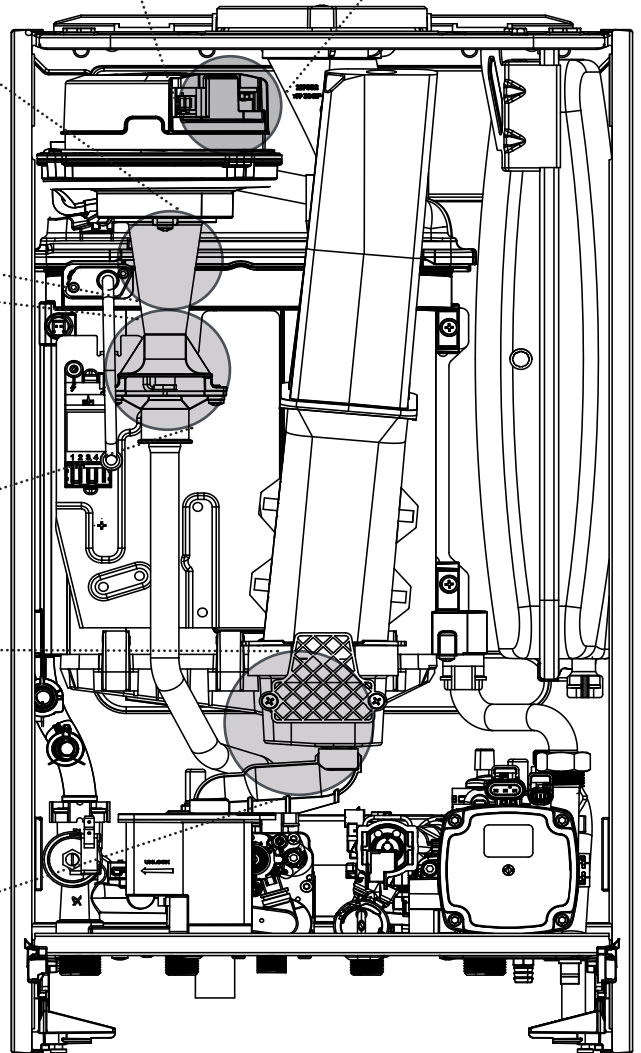
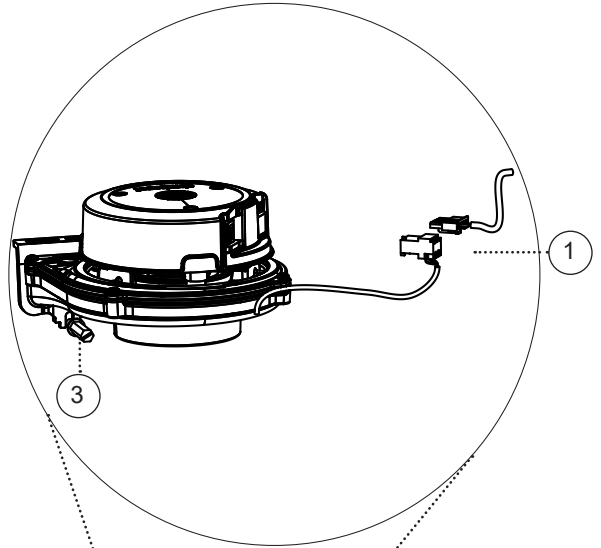
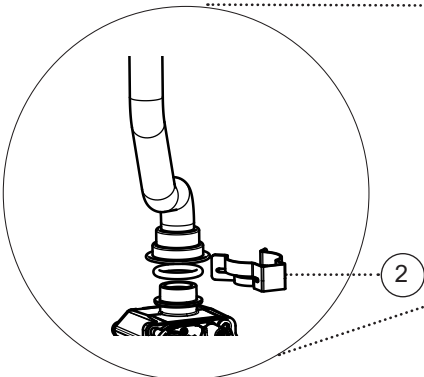
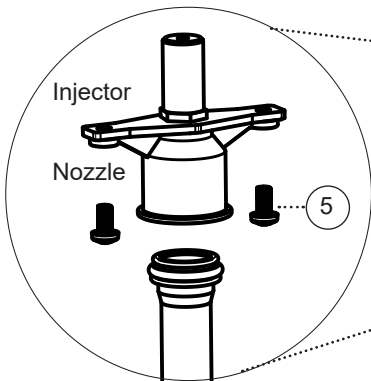
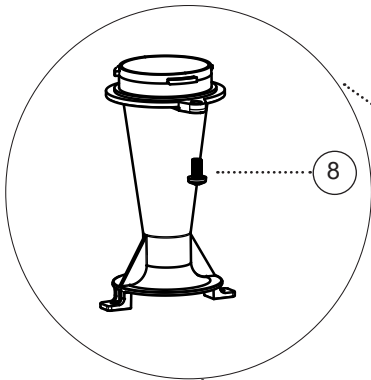

## 3.7 BURNER REMOVAL AND CLEANING

Refer to Section 3.2

1. Remove the 2 burner front fixing screws and the 2 rear extended nuts.
2. Lift and pull forward the burner from the combustion chamber by holding the burner with two finger in the air inlet duct and your thumb on the top of the burner.
3. Tilt the burner towards yourself so that it raises to the vertical position.

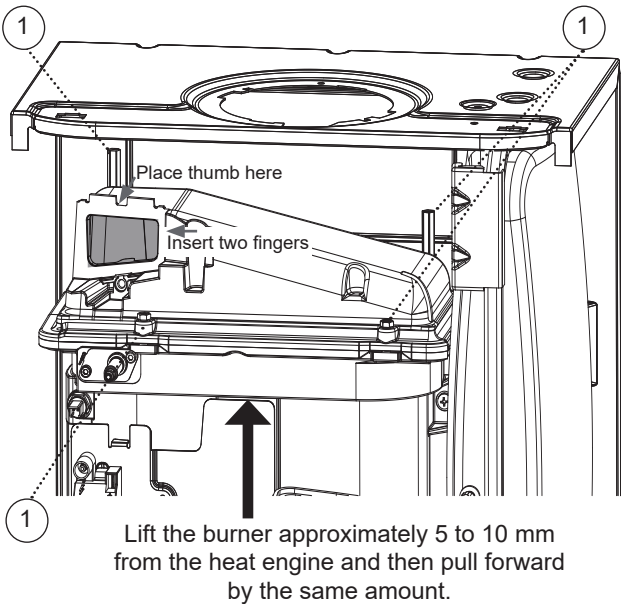

4. Pull the burner out from the left hand side of the boiler once it is in the vertical position.

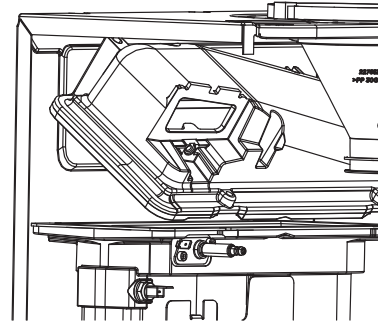

5. Carefully brush the ceramic burner with a soft non metallic bristle brush.

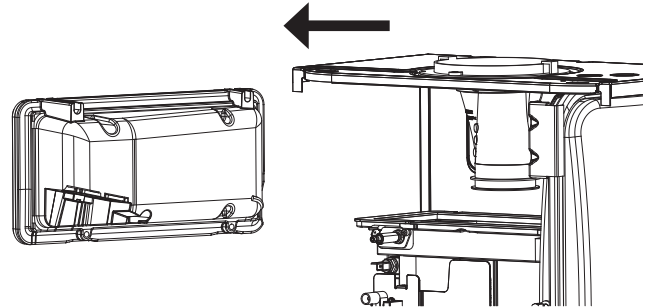

SCAN for video



## 3.8 CLEANING THE HEAT EXCHANGER

1. Replace the sump cover prior to the water flush process.
2. Thoroughly flush the heat exchanger by pouring water into the top of the combustion chamber ensuring the full surface of the heat exchanger is cleaned. Avoid pouring water over the electrode.
3. Remove the sump cover and clean loose deposits from the sump.
4. Inspect the ignition/detection electrode. Ensure that it is clean and in good condition - replace if necessary.
5. Check that the ignition gap is correct.

Refer to Section 3.9

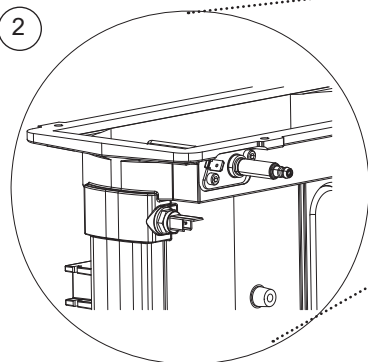

Combined Ignition Detection Electrode

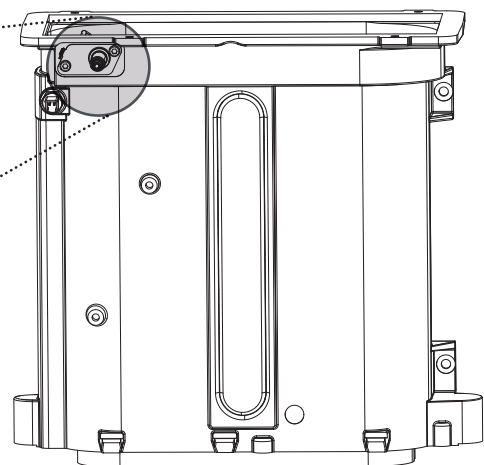

## 3.9 IGNITION / DETECTION ELECTRODE REPLACEMENT / INSPECTION

Refer to Section 3.2

1. Remove the fan.

Refer to Section 3.6

2. Remove the flue manifold.

Refer to Section 3.5

3. Remove the burner.

Refer to Section 3.7

4. When servicing the boiler inspect the condition of the electrode and check the dimensions shown. If there is damage to the electrode continue to follow steps below for replacement.

5. Unplug the ignition lead from the electrode.

6. Remove the earth lead from the electrode.

7. Remove the 2 screws holding the electrode to the combustion chamber.

8. Remove the electrode.

9. Fit the new electrode, using the new gasket supplied. Check dimensions as shown.

Refer to Section 2.27 & 2.29

Ignition /Detection Electrode

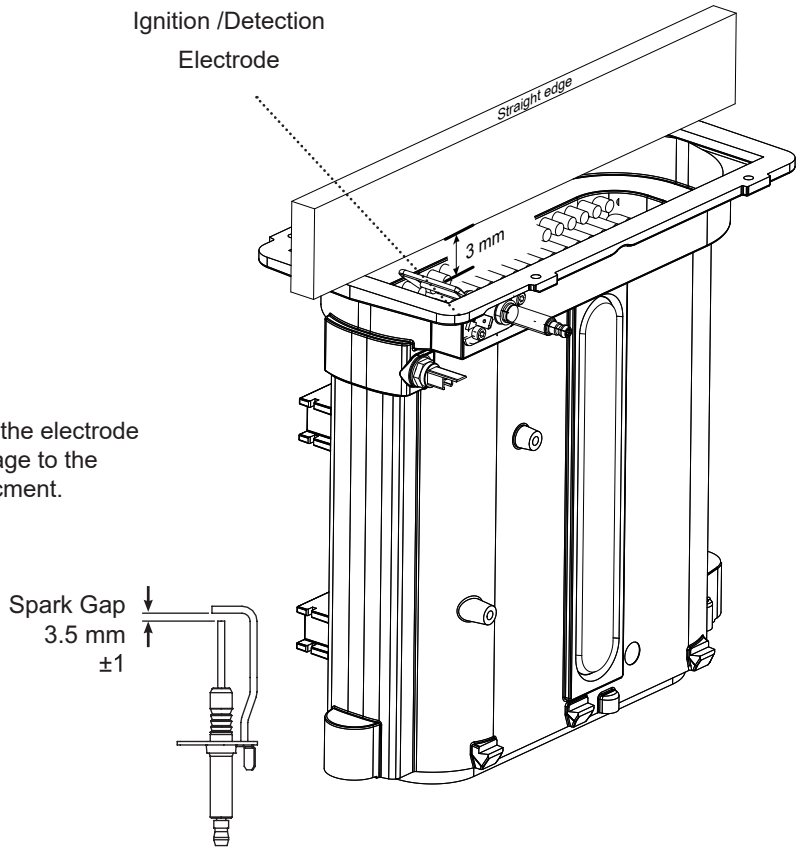

## 3.10 CLEANING / REPLACING THE CONDENSATE TRAP

**CAUTION:** Keep trap upright when removing

1. Pull off the rubber pipe at the sump drain.
2. Turn the trap clockwise to disengage and lift to remove.
3. Clean and fill trap with water.

SCAN for video

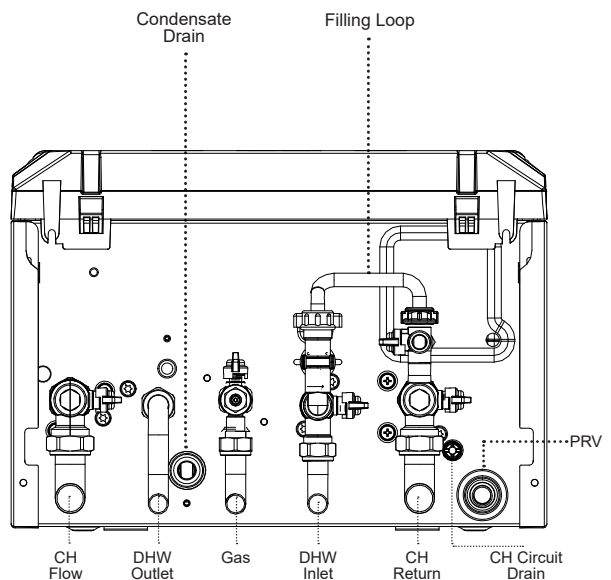
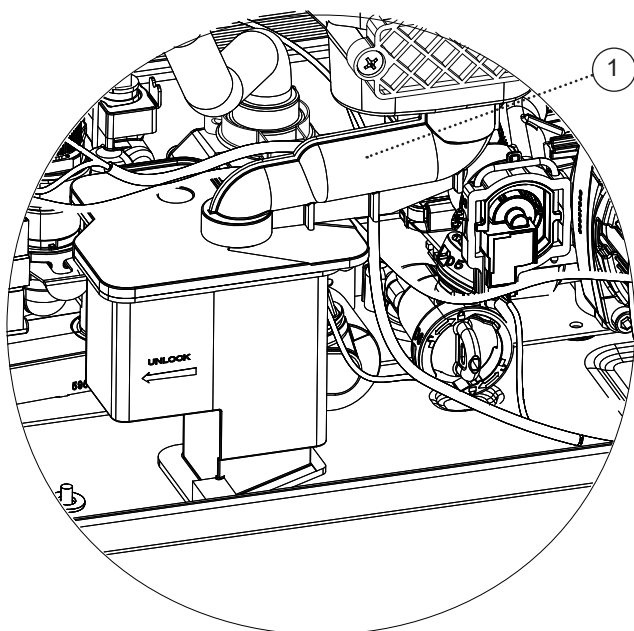

## 3.11 DHW FILTER & DHW FLOW REGULATOR CLEANING/REPLACEMENT

Refer to Section  
3.2

1. Isolate the DHW system.

Refer to Section  
3.3

2. Turn the housing anti clockwise and pull forward to remove the cartridge. Be prepared for some water release.

3. Using a pair of pliers, pull out the plastic filter/flow regulator.
4. Clean or replace filter as necessary.
5. Reassemble.
6. Reestablish the Cold mains supply to the boiler.

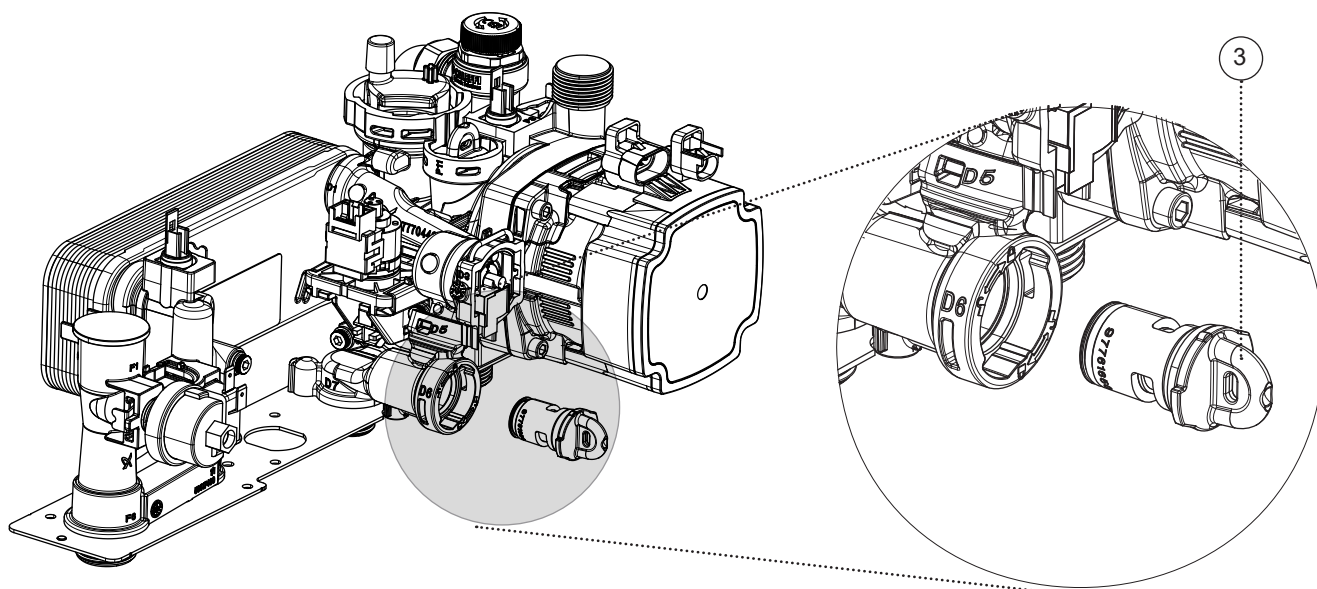

SERVICING

## 3.12 BURNER INJECTOR REPLACEMENT

Refer to Section  
3.6

## 3.13 BURNER REPLACEMENT

Refer to Section  
3.2 & 3.7

SCAN  
for video



## 3.14 RETURN THERMISTOR REPLACEMENT

Refer to Section 3.2

1. Isolate and drain down the boiler.
2. Remove the clip from the pump housing and remove the thermistor.
3. Disconnect the electrical lead from the thermistor.
4. Reconnect the electrical lead to the new thermistor and reassemble, ensuring that the thermistor is fully engaged and the clip is correctly located.

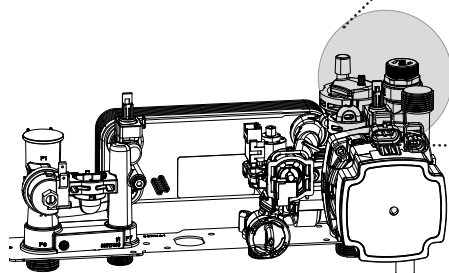
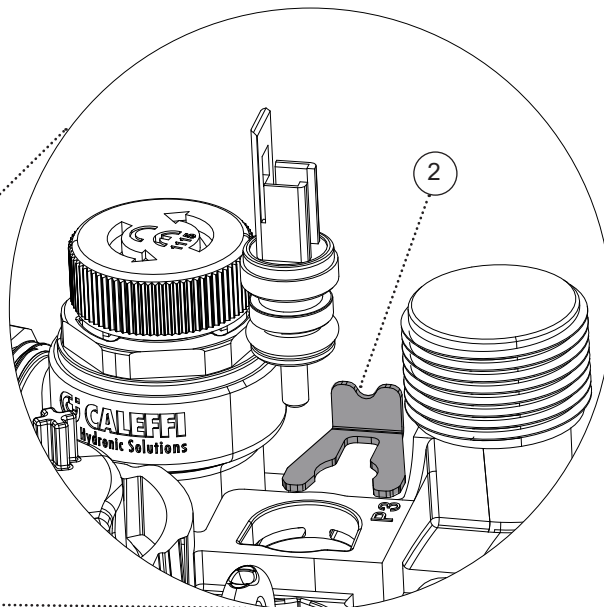

## 3.15 SPARK GENERATOR REPLACEMENT

Refer to Section 3.2

1. Disconnect the leads from the spark generator.
2. Gently push down the generator to release the top clip from the gas valve mounting bracket.
3. Lift the spark generator up and out of the bottom retaining location point.
4. Fit the new spark generator and re-assemble ensuring that the the earth lead is replaced.

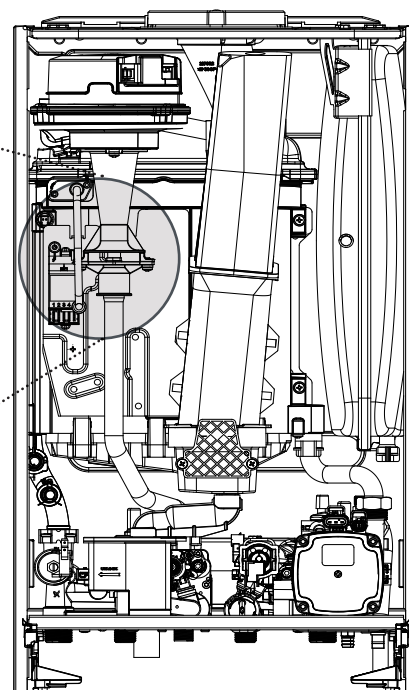
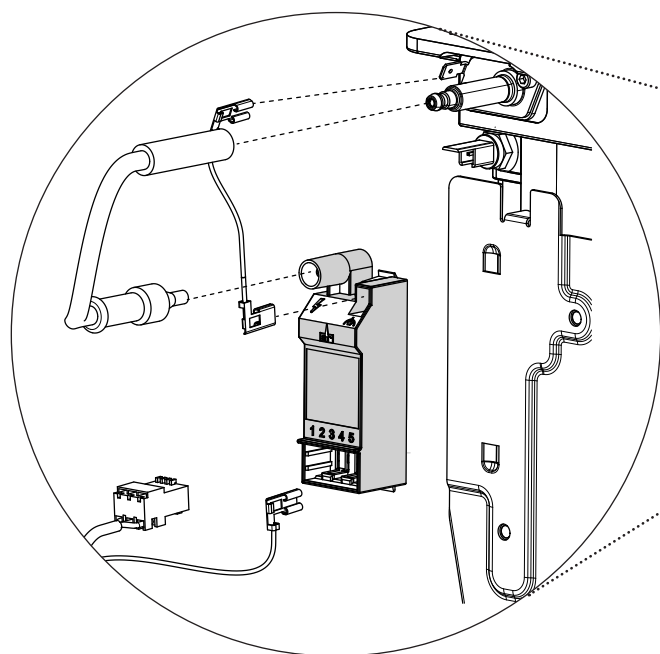

## 3.16 GAS CONTROL VALVE REPLACEMENT

Refer to Section  
3.2

1. Disconnect and remove the trap and rubber connector.

Refer to Section  
3.10

2. Unplug the electrical lead connection from the gas control valve.
3. Remove the outlet gas valve clip and slide the pipe upwards.
4. Undo the gas inlet pipe union at the inlet to the gas valve.
5. Undo the two screws fixing the gas valve to the chassis base and lift the gas valve upwards.
6. Fit the new gas control valve ensuring that the 'o' ring and sealing washer are in place and reconnect gas and electrical connections.
7. Refit the trap and fill.
8. Ensure all gas valve connections are gas tight with a gas soundness check up to the gas control valve.

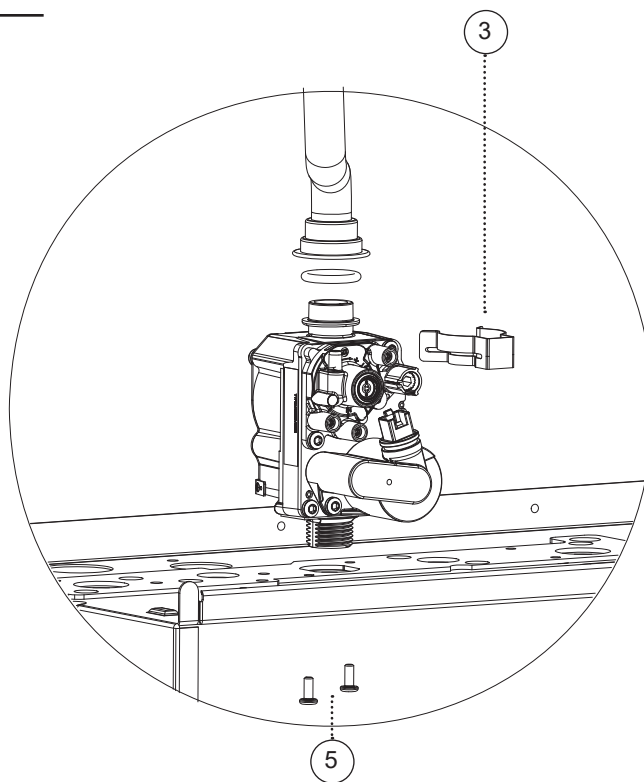

## 3.17 DIVERTER VALVE ACTUATOR REPLACEMENT

Refer to Section  
3.2

To remove the motor:

1. Remove the condensate trap.

Refer to Section  
3.10

2. Press Down on the hot keys until the diverter valve mid position is highlighted. Ensure that the diverter valve is in mid position.

3. Disconnect the electrical plug from the motor.
4. Fit the new motor ensuring the arm is correctly engaged in the metal fork and reassemble ensuring the condensate trap is refilled with water.
5. Reconnect the electrical plug to the motor.

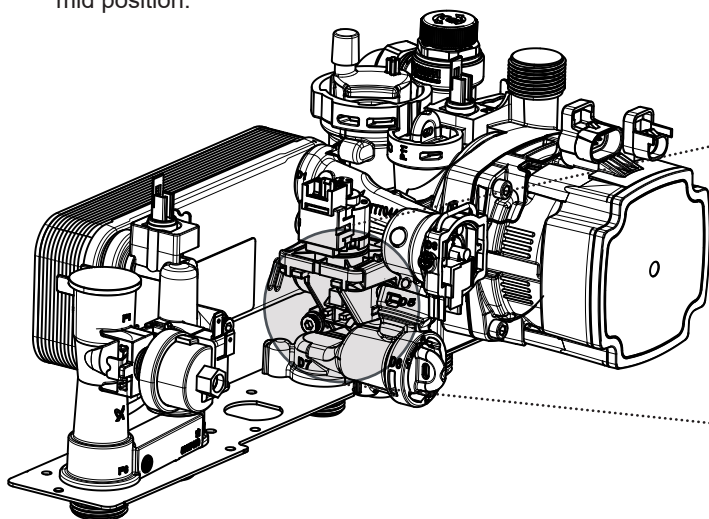

## 3.18 CONDENSATE TRAP REPLACEMENT / CLEANING

Refer to Section  
3.10

## 3.19 PRIMARY PCB REPLACEMENT

**WARNING:** It is critical that the correct boiler size and fuel type is entered in to the boiler.

**CAUTION:** Fit the earth strap provided with the PCB to your wrist and secure to a suitable earth on the boiler chassis.

Refer to Section  
3.2

1. Remove and keep the screw.
  2. Carefully release the four retaining clips and remove control box cover.
  3. Unplug all lead connections to the PCB.
  4. Spring out the four side retaining clips and pull the PCB upwards to clear the corner retaining posts.
  5. Fit the new PCB.
  6. Re-connect all plug connections.
  7. Reassemble.
  8. Switch mains power on, wait for "uP" to be shown.
  9. Simultaneously press Mode & Restart buttons so that "oF" is shown.
  10. Switch mains power off and wait for 5s.
  11. Switch mains power on, wait for "F9 5U" to be shown
  12. Rotate the CH Temperature Knob until "F9 C" is shown.
  13. Press Restart.
  14. Rotate the CH Temperature Knob until "F9 n" is shown.
  15. Press Restart.
  16. Rotate the Temperature Knob until the appropriate boiler output is shown (24 kW, 30 kW or 35 kW). Press Restart.
  17. The boiler type (C), gas type (n), output (24/30/35) and parameter set number will be shown in rotation.
- If this is OK press Restart to complete the configuration, otherwise switch mains power off to start again.

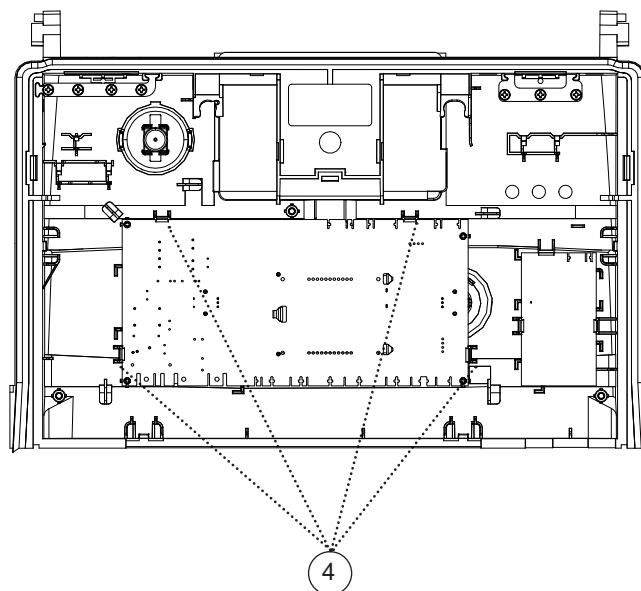
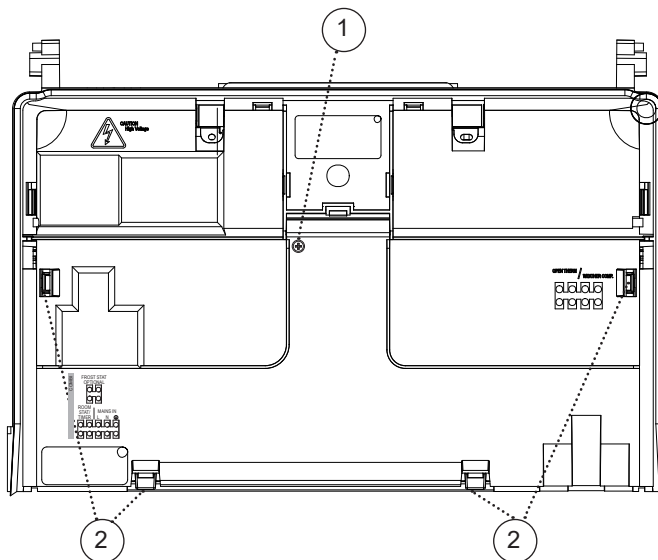

## 3.20 DHW FLOW TURBINE SENSOR REPLACEMENT

Refer to Section  
3.2

1. Drain the DHW system.

Refer to Section  
3.3

2. Pull off the electrical connection.

3. Using a suitable tool, lift and remove the retaining clip.
4. Use the clip to ease the turbine sensor from its housing.
5. Reassemble.

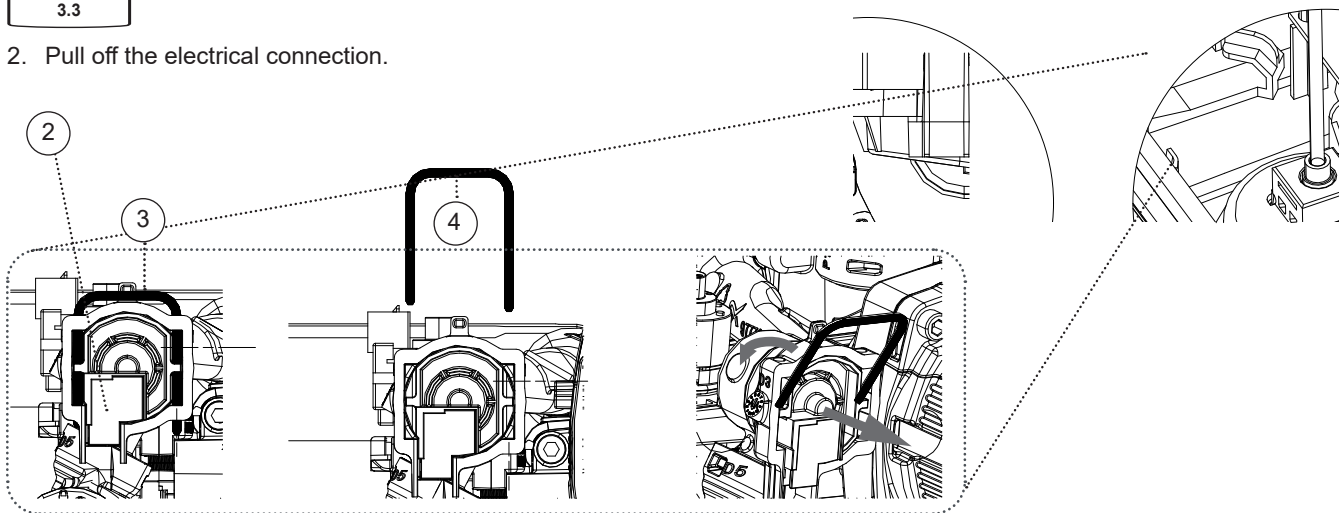

SERVICING

## 3.21 PRESSURE GAUGE REPLACEMENT

Refer to Section  
3.2

1. Drain the heating system.

Refer to Section  
3.3

2. Remove the boiler front (see section 3.4), lower the control panel and remove the control box cover.
3. Ensuring there is no pressure in the system unclip the C clip from the flow pipe port and remove the capillary connection together with 'O' ring.
4. Releasing the two retaining clips on the pressure gauge ease the pressure gauge through the front of the control panel.

5. Fit the new pressure gauge from the front of the lower control panel ensuring correct orientation. Locate push fit connection into flow pipe ensuring 'O' ring in place and secure with the C clip.
6. Refill the boiler.

Refer to Section  
2.18

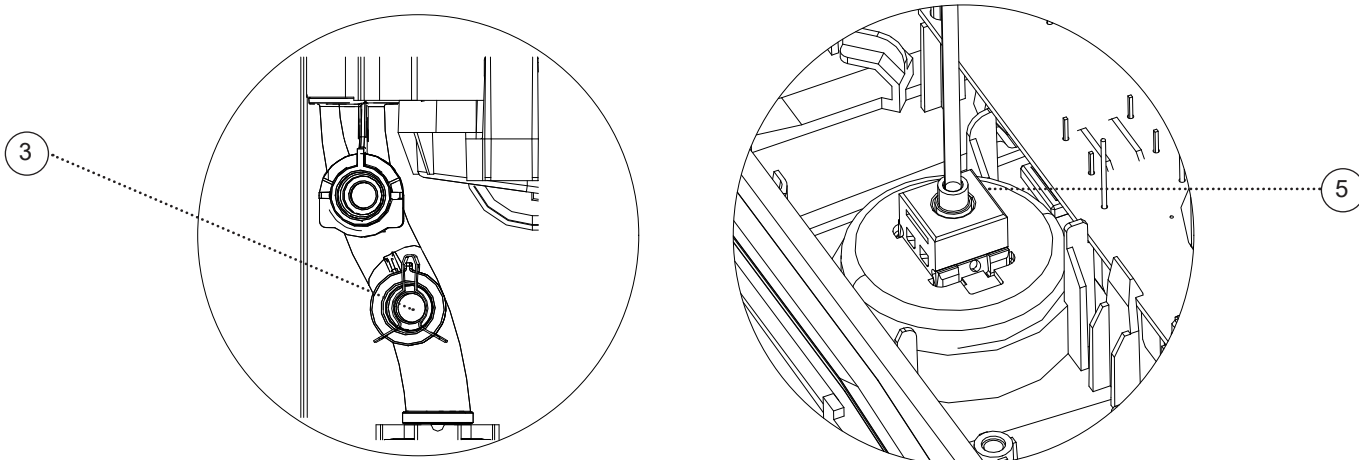

## 3.22 PRV REPLACEMENT

Refer to Section 3.2

1. Drain the boiler.

Refer to Section 3.3

2. Remove the trap and rubber pipe.
3. Pull out and remove the clip retaining the PRV.
4. Lift out the PRV/pipe assembly.
5. Remove the pipe and transfer to the new PRV.
6. Reassemble ensuring the retaining clip is correctly fitted.

7. Check the operation of the PRV by raising the water pressure until the valve lifts. This should occur within 0.3 bar of the preset lift pressure.
8. Check no escape of water occurs except at the discharge point
9. Release water from the system until the minimum system design pressure is reached; 1.0 bar if the system is to be pre-pressurised.

SCAN  
for video



Refer to Section 2.17

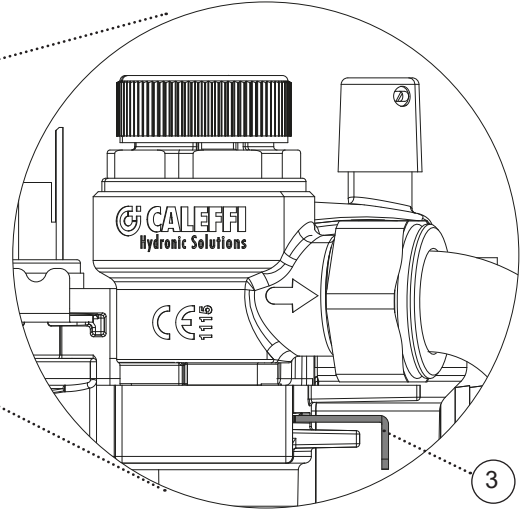
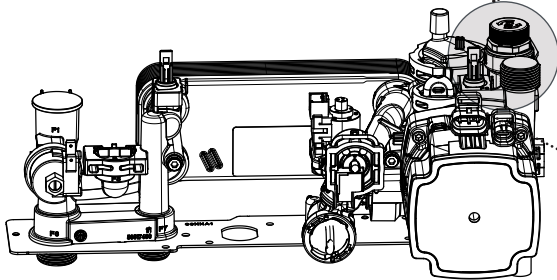

## 3.23 PUMP AUTOMATIC AIR VENT REPLACEMENT

Refer to Section 3.2

1. Drain the boiler.

Refer to Section 3.3

2. Remove the expansion vessel.

Refer to Section 3.31

3. Firstly, increase access area by disconnecting the 22 mm pipe connection at top of pump manifold and bottom of heat exchanger and remove pipe.
4. The automatic air vent head is retained in the pump body with a bayonet connection. The air vent head and float assembly is removed by turning the head anti-clockwise (viewed from above) and pulling upwards.

5. Reassemble. Ensure the air vent head 'o' ring seal is fitted.
6. Fully open the Pump Automatic Air Vent.
7. Refill the boiler. Check for leaks around the new air vent joint.

Refer to Section 2.18

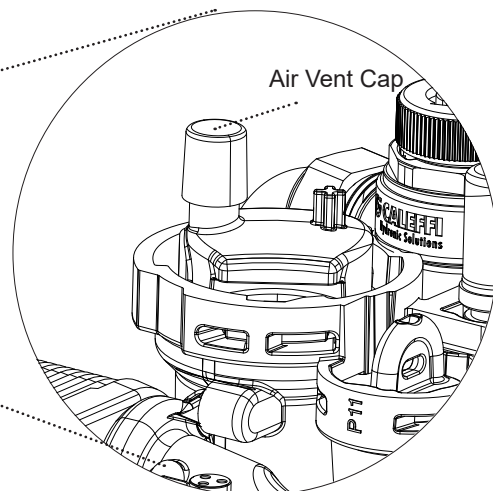
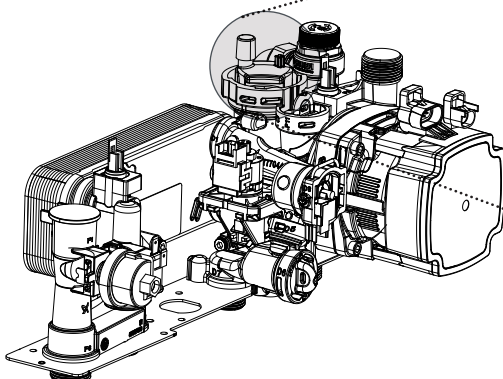

## 3.24 REPLACEMENT OF DHW THERMISTOR

Refer to Section  
3.2

1. Isolate the DHW system
2. Remove the retaining clip and extract the thermistor.  
Be prepared for some water release.
3. Disconnect the wiring harness.

4. Fit the replacement thermistor and reassemble.
5. Reestablish the DHW supply, turn on a hotwater tap checking for leaks

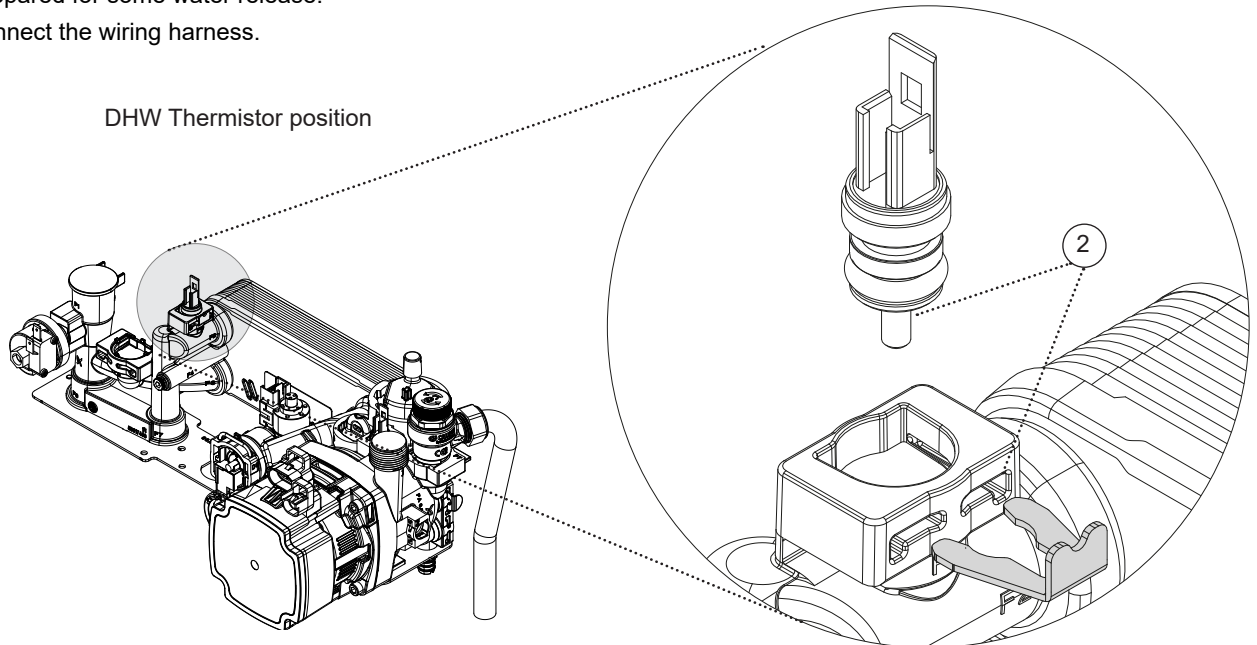

## 3.25 DHW PLATE HEAT EXCHANGER REPLACEMENT

Refer to Section  
3.2

1. Drain the boiler.  
Refer to Section 3.3
2. Remove condensate trap.  
Refer to Section 3.10
3. Remove the 2 hex screws securing the plate heat exchanger to the composite housings.
4. Manoeuvre the plate heat exchanger out of the top LH or centre of the controls area. Be aware of any water spillage.

5. Fit the new plate heat exchanger, using the new o-rings supplied.

**Note.** Ensure that the depressions are on the bottom prior to fitting.

6. Refill the boiler.  
Refer to Section 2.18

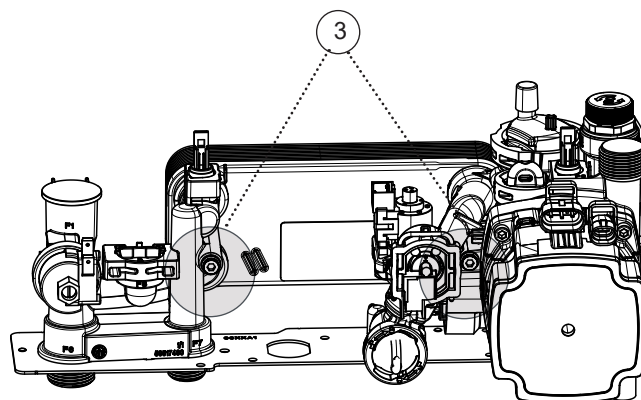

SCAN  
for video



## 3.26 DIVERTER VALVE BODY ASSEMBLY REPLACEMENT

Refer to Section  
3.2

To remove the valve body assembly:

1. Drain the boiler.

Refer to Section  
3.3

2. Remove the condensate trap.

Refer to Section  
3.10

3. Remove the electrical plug from the diverter valve.
4. Place a flat bladed screwdriver in the diverter valve motor body slot provided and ease out the motor.

Refer to Section  
3.17

5. Remove the return thermistor electrical connection.

Refer to Section  
3.14

6. Remove the pump electrical connections.

Refer to Section 3.27 No. 2.

7. Remove DHW Turbine electrical connection.

Refer to Section 3.20 No. 2.

8. Remove the DHW plate heat exchanger (note orientation).

Refer to Section  
3.25

9. Loosen the nut above pump and rotate the pipe.

10. If required remove expansion vessel connection hose.

Refer to Section  
3.31

11. If required remove connection to PRV discharge pipe.

12. Remove the DHW inlet and CH return connection situated beneath the boiler.

13. Remove the four torx head screws fixing the return manifold to the boiler sheet steel base.

14. Lift the manifold assembly and remove from boiler.

15. Twist and remove the DHW manifold.

16. Remove the two diverter valve body fixing screws and withdraw the diverter valve body assembly.

17. Fit the new diverter valve body assembly and replace the two fixing screws.

18. Refit the DHW manifold, fit the assembly back to the boiler and reassemble.

19. Refill the boiler and check for leaks. Check that the boiler operates in both DHW & CH modes.

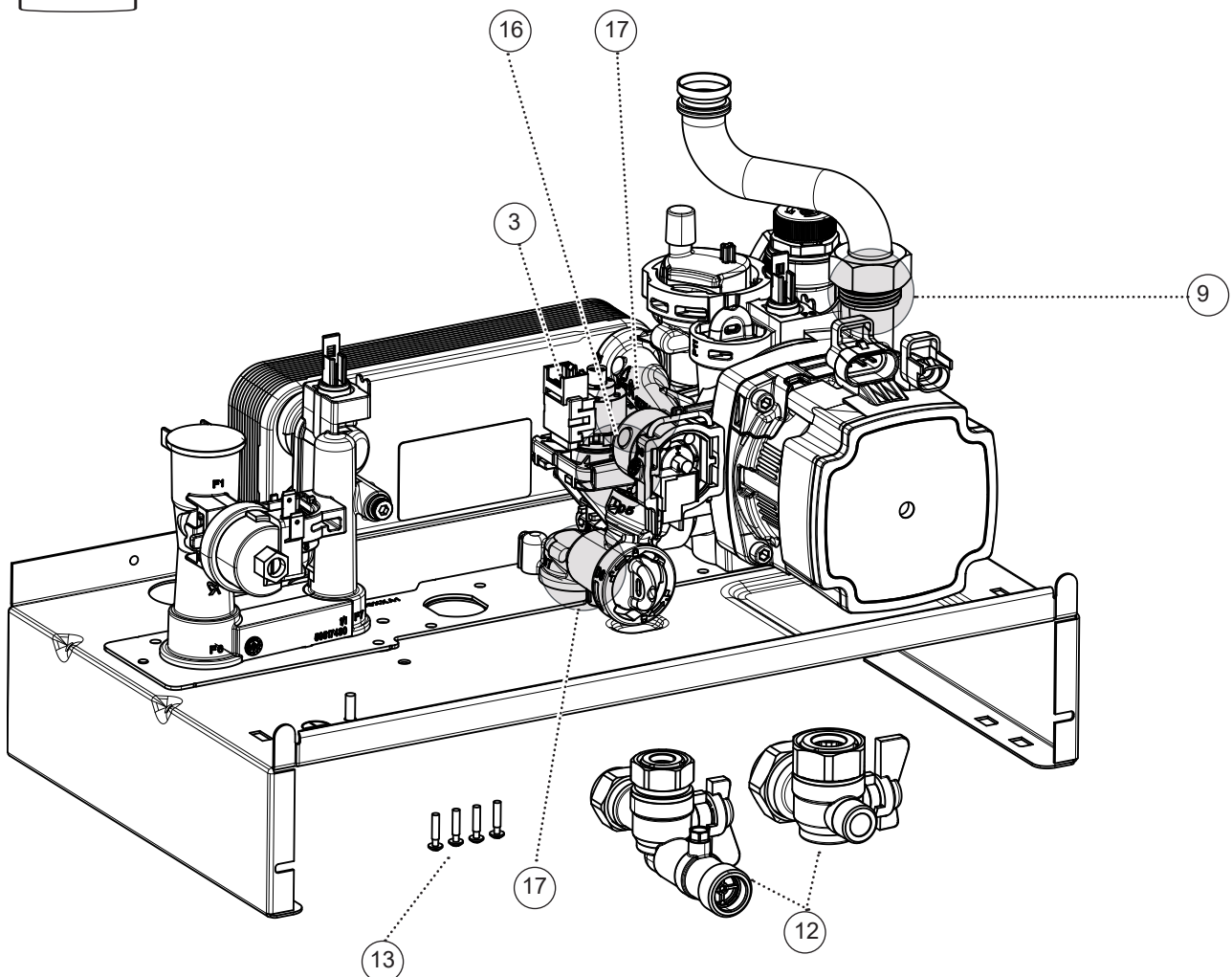

## 3.27 PUMP HEAD REPLACEMENT

Refer to Section  
3.2

1. Drain the boiler.

Refer to Section  
3.3

2. Disconnect the two electrical leads from the pump.
3. Remove the 4 hex screws retaining the pump head.
4. Remove the pump head.  
Be aware of water spillage.
5. Fit the new pump head.
6. Refill the boiler.

Refer to Section  
2.18

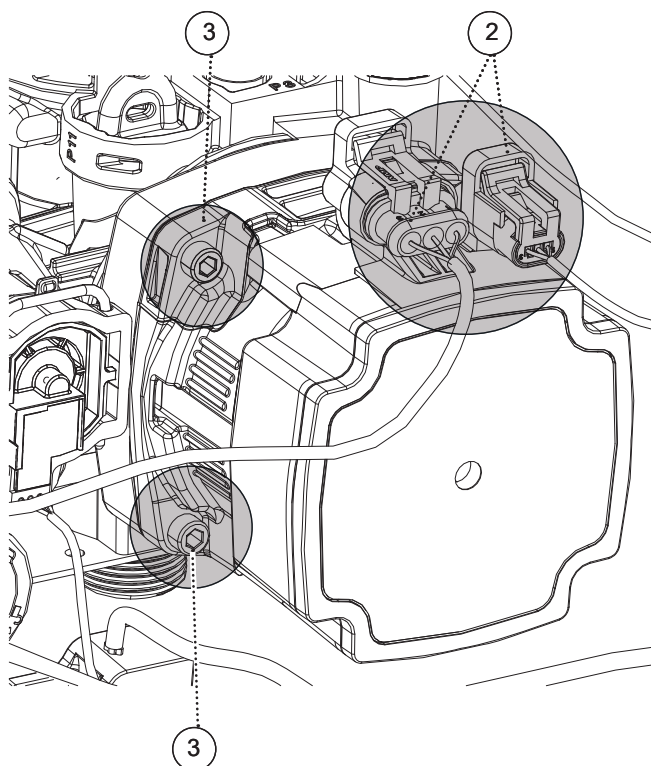

SERVICING

## 3.28 CH WATER PRESSURE SWITCH REPLACEMENT

Refer to Section  
3.2

1. Drain the boiler.

Refer to Section  
3.3

2. Pull off the two electrical connections.
3. Using a suitable tool, pull out the metal retaining clip.
4. Carefully withdraw the pressure switch.
5. Fit the new pressure switch and reassemble. Ensuring that the 'O' ring is fitted, replace clip.
6. Refill the boiler.

Refer to Section  
2.18

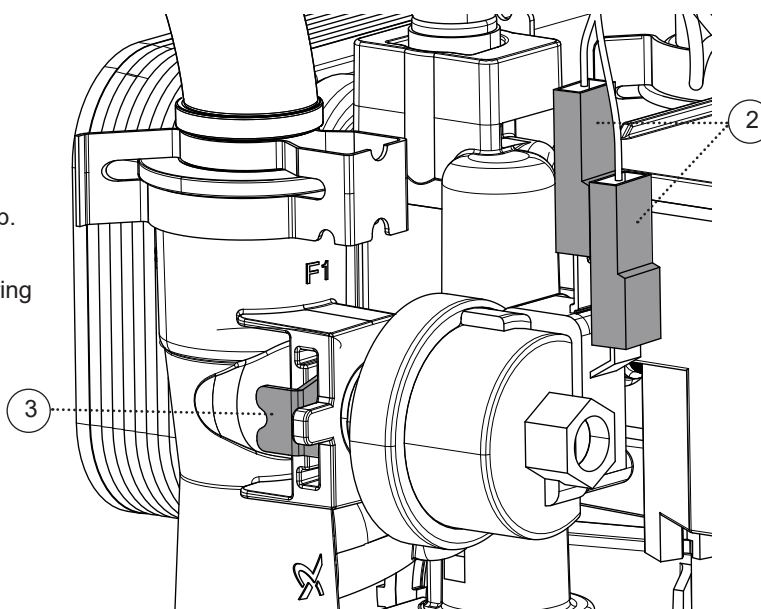

## 3.29 FLOW THERMISTOR REPLACEMENT

Refer to Section  
3.2

1. Drain down the boiler.

Refer to Section  
3.3

2. Unplug the electrical lead.

3. Unscrew the thermistor (to facilitate removal a 13 mm socket spanner should be used).

4. Fit the new thermistor using the sealing washer provided.

5. Reassemble in the reverse order.

6. Refill the boiler.

Refer to Section  
2.18

7. Check that the boiler operates in both DHW & CH modes.

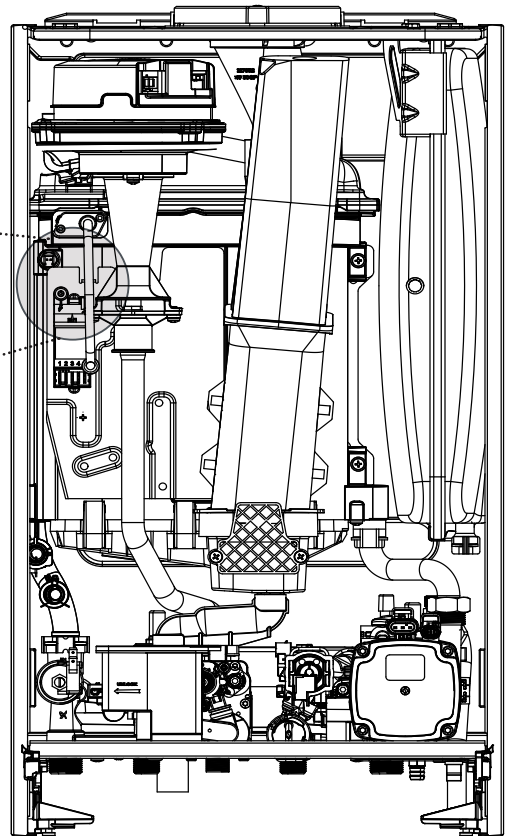
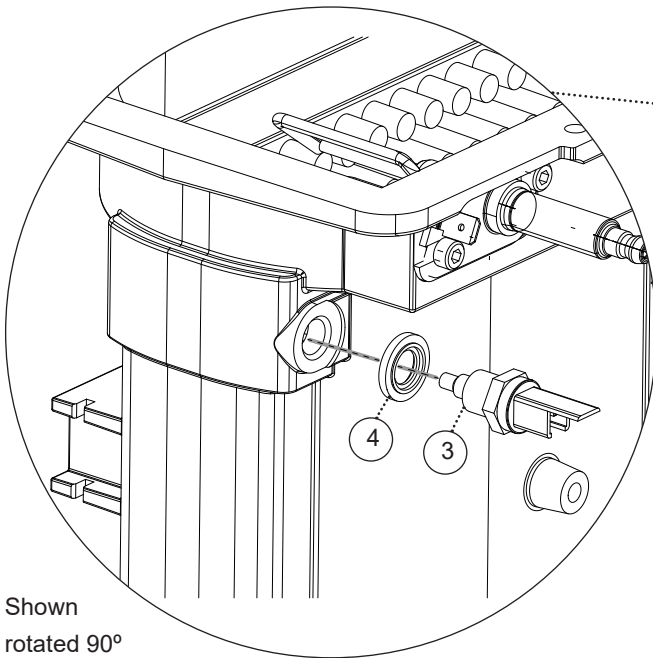

## 3.30 HEAT ENGINE REPLACEMENT

Refer to Section  
2.27

**CAUTION:** Protect the gas and electrical controls with a waterproof sheet.

Refer to Section  
3.2

1. Drain the boiler (CH Circuit Drain).

Refer to Section  
3.3

2. Undo the two screws and remove the sump cover retaining the lower flue manifold.
3. Lift the manifold to clear the bottom sealing gasket and remove manifold.

Refer to Section  
3.5

4. Remove the fan / venturi assembly and place on one side.

Refer to Section  
3.6

5. Remove the burner and place on one side.

Refer to Section  
3.7

6. Remove the heat exchanger flow thermistor.

Refer to Section  
3.29

7. Remove the spark generator and trap.

Refer to Section  
3.15 & 3.10

8. Remove the gas valve.

Refer to Section  
3.16

9. Remove the expansion vessel.

Refer to Section  
3.31

10. Remove the 2 M5 screws retaining the spark generator, mounting bracket and transfer bracket to the new heat exchanger.

11. Undo the pump union nut, remove clip and remove pipe from expansion vessel.

12. Remove the two retaining pipe clips and remove pipes.

13. Remove the condensate rubber pipe.

Refer to Section  
3.10 No.1

14. Remove the two heat exchanger fixing screws.

15. Remove the heat exchanger, slide out of location bracket.

16. If replacement sump required: Rotate heat exchanger assembly 180°. Place new sump onto heat exchanger, ensuring correct orientation and seal is in place. Then gently apply pressure to the base of the sump at each tab fixing point and engage tabs onto the heat exchanger.

17. Reassemble, ensuring the heat exchanger is located correctly in the LHS retaining bracket. Replace any new 'O' rings supplied with new heat exchanger and replace gaskets or seals if any sign of damage is evident. When replacing the spring clips located on the return pipe connection, ensure clip is oriented to correctly match connecting pipe diameters.

18. Ensure the trap is filled with water.

Refer to Section  
3.10

19. Refill the boiler and check for leaks.

Refer to Section  
2.18

20. Ensure all gas valve connections are gas tight with a gas soundness check up to the gas control valve.

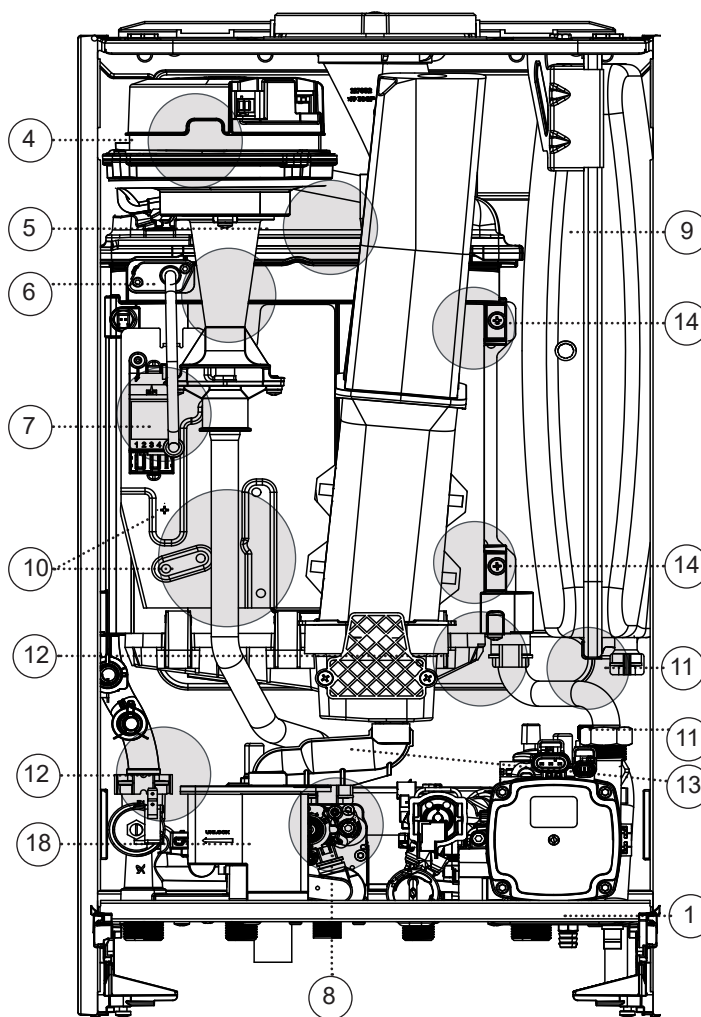

### 3.31 EXPANSION VESSEL RECHARGING & REPLACEMENT

Refer to Section  
3.2

#### RECHARGING

1. Remove the charge point cover.
2. Recharge the tank pressure to 0.75 bar.
3. Reassemble.
4. Check that the boiler operates in both DHW & CH modes.

#### REPLACEMENT

5. Drain the boiler CH circuit.

Refer to Section  
3.3

6. Remove the retaining clip on the vessel water connection pipe and remove the pipe.
7. Support the expansion vessel and unscrew the 2 screws from the securing bracket, located on the top of the boiler, and remove.

Note the position of the bracket on the vessel.

8. Remove the expansion vessel.
9. Fit the new expansion vessel.
10. Reassemble in reverse order ensuring the clip and the seal is in place.
11. Refill the boiler and check for leaks.

Refer to Section  
2.18

12. Check that the boiler operates in both DHW & CH modes.

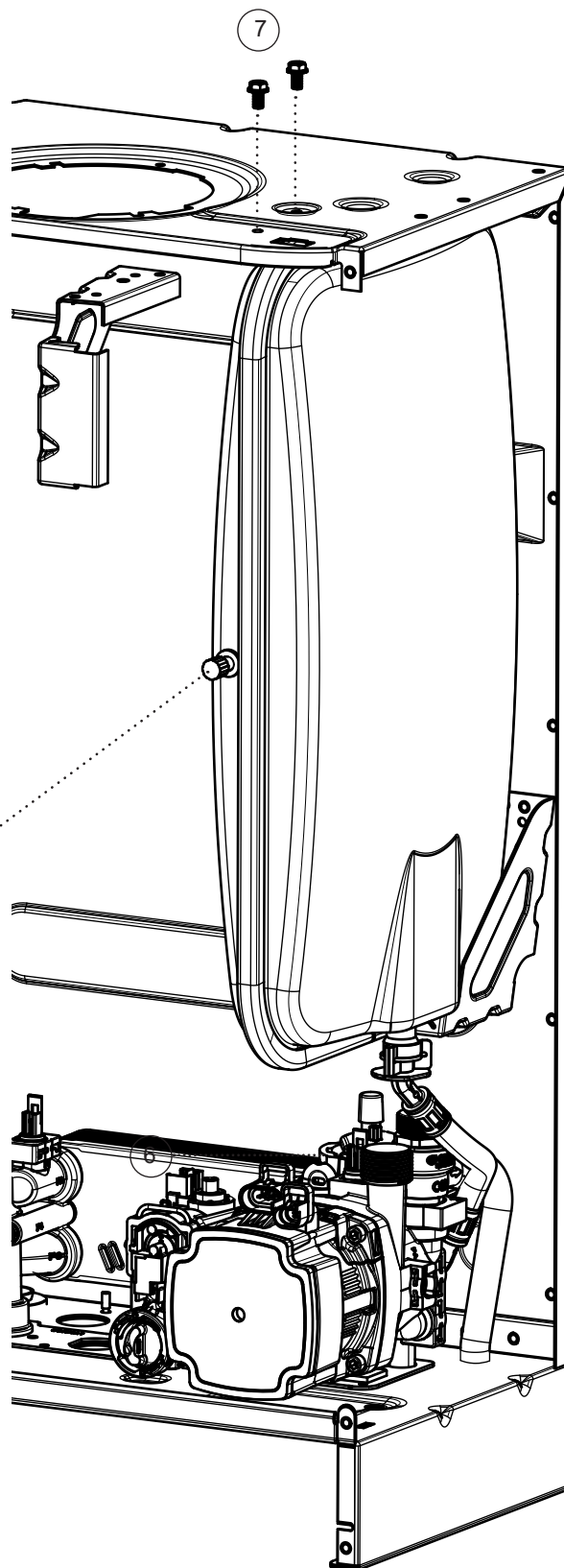

Recharge  
Point

1

## Section 4 - Fault Finding

### 4.1 FAULT FINDING MAIN MENU

'L 01'	→	Go to Section 4.2: Flow Temperature Overheat Lockout
'L 02'	→	Go to Section 4.3: Ignition Lockout
'L 0C'	→	5 Restarts within 15 minutes: Turnpower off & on
'L 06'	→	Go to Section 4.4: False Flame Lockout
'F 01'	→	Go to Section 4.5: Low Water Pressure
'F 02'	→	Go to Section 4.6: Flame Loss
'F 03'	→	Go to Section 4.7: Fan Fault
'L 04' or 'F 04'	→	Go to Section 4.8: Flow Thermistor Fault
'L 05' or 'F 05'	→	Go to Section 4.9: Return Thermistor Fault
'F 06'	→	Go to Section 4.10: Outside Sensor Fault
'F 07'	→	Low Mains Voltage: Contact Electricity Provider
'F 09'	→	PCB Fault: Replace PCB
'F 0C'	→	DHW Thermistor Fault: Go to Section 4.15
'F 0U'	→	Go to Section 4.14: Flow/Return Differential greater than 50°C
'L 0d'	→	Go to Section 4.3: Ignition Lockout: Blocked Flue/Condensate
'F 0t'	→	Room Thermostat Fault: Check Room Stat & connections
'F 10'	→	Spark Generator Fault: Check wiring, if OK replace spark generator
'F 12'	→	Pump Rotor Blocked: Clear blockage
'F 13' or 'F 15' or 'F 17'	→	Pump Fault: Check pump wiring, if OK replace pump
'F 14'	→	High Mains Voltage: Contact electricity provider
'F 16'	→	Gas Valve Fault: Check gas valve wiring, if OK replace gas valve
'dU'	→	Diverter Valve in midposition for service, press Restart to end
No CH, but HW OK	→	Go to Section 4.11
No HW, but CH OK	→	Go to Section 4.12
No Display	→	Go to Section 4.13

## 4.2 'L 01' - OVERHEAT LOCKOUT

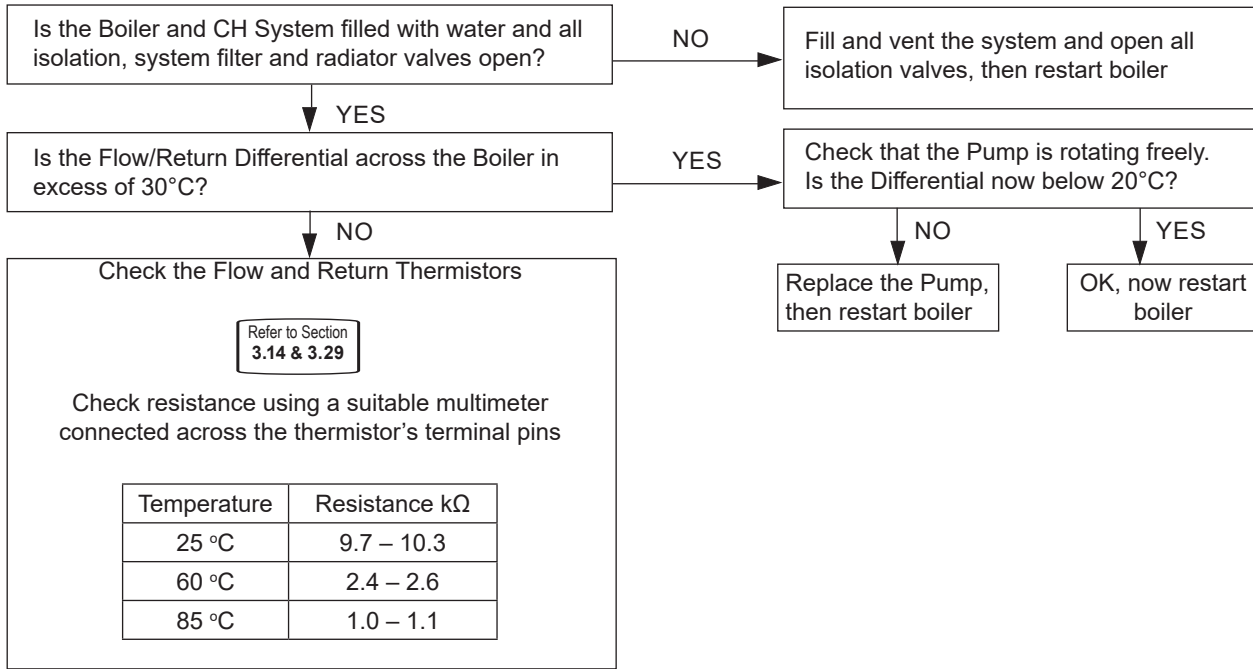

## 4.3 'L 02' - IGNITION LOCKOUT

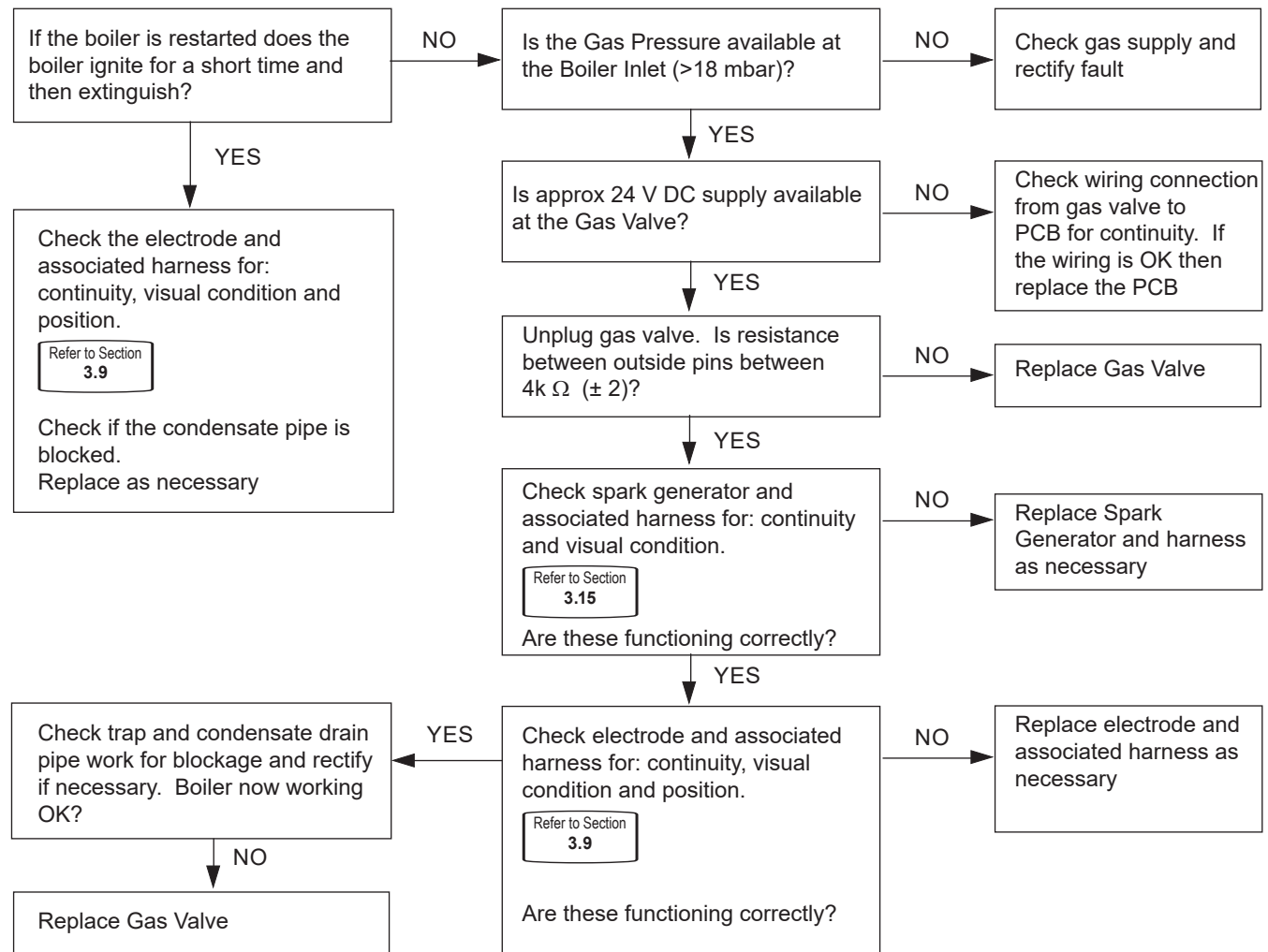

## Section 4 - Fault Finding

### 4.4 'L 06' - FLAME ON BEFORE GAS VALVE ON

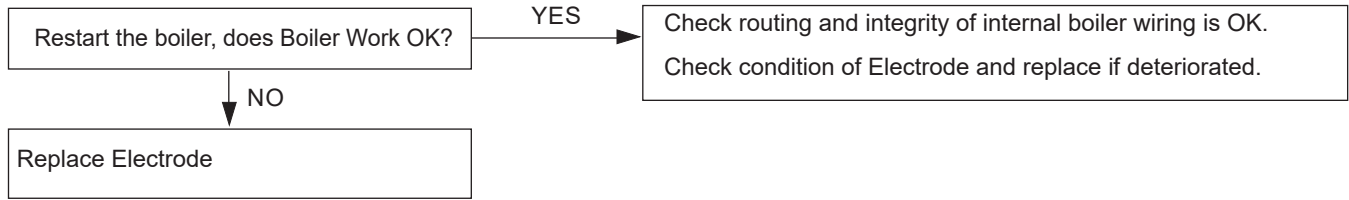

### 4.5 'F 01' - LOW WATER PRESSURE

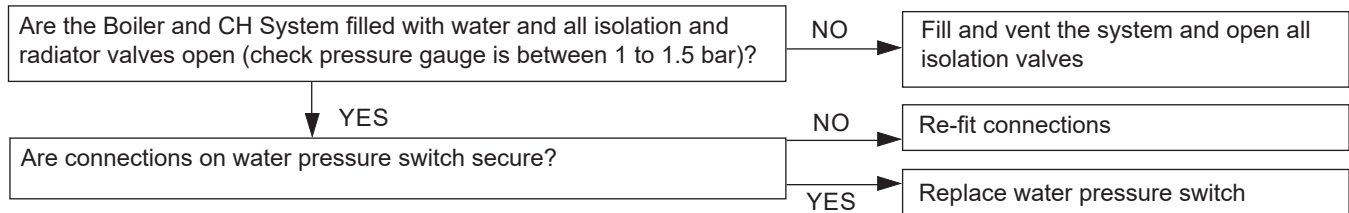

### 4.6 'F 02' - FLAME LOSS

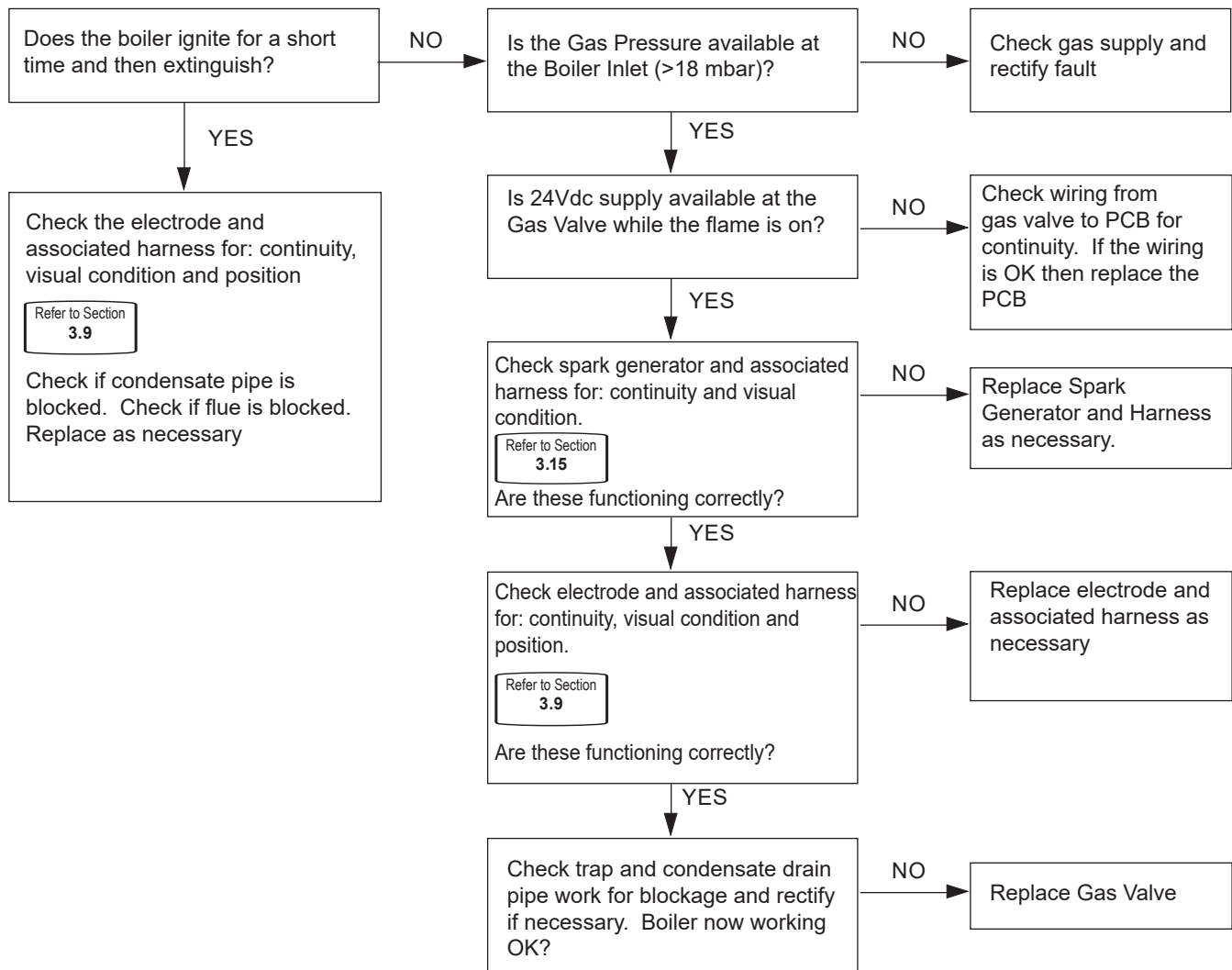

## 4.7 'F 03' - FAN FAULT

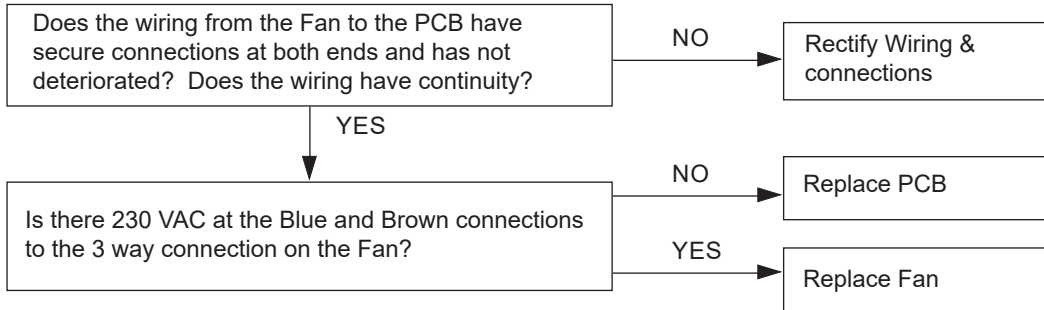

## 4.8 F 04 OR L 04' - FLOW THERMISTOR FAULT

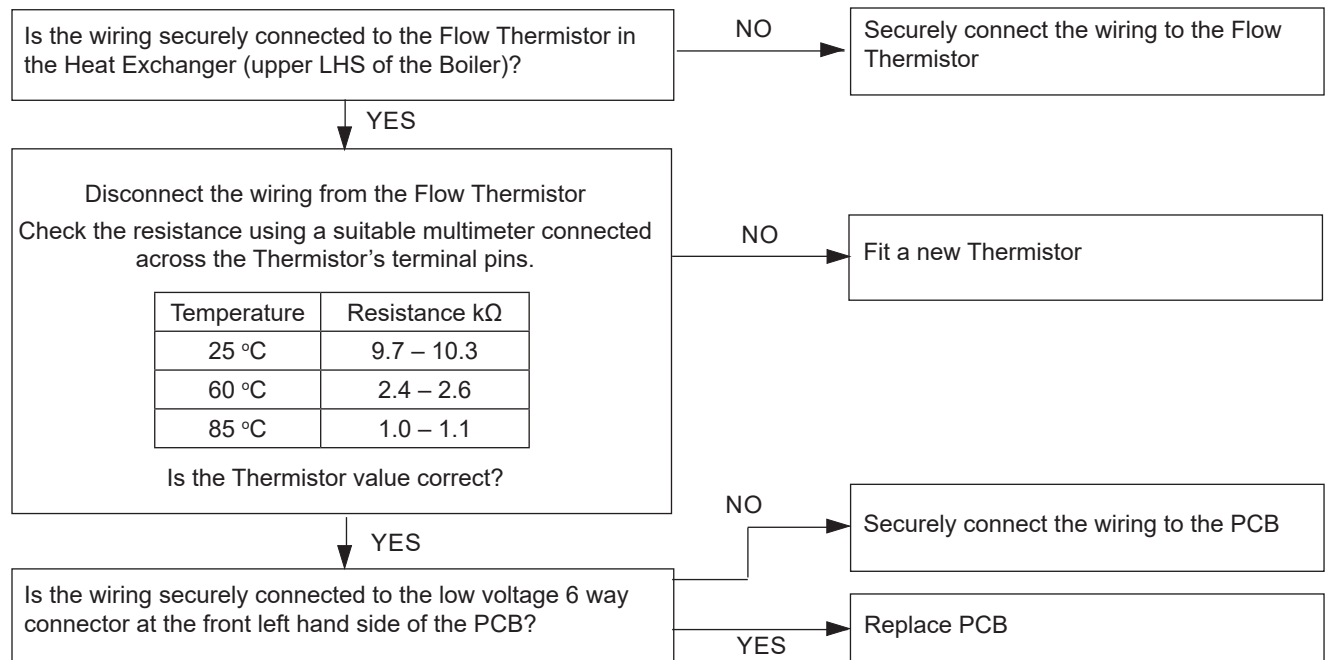

### 4.9 'F 05 OR L 05' - RETURN THERMISTOR FAULT

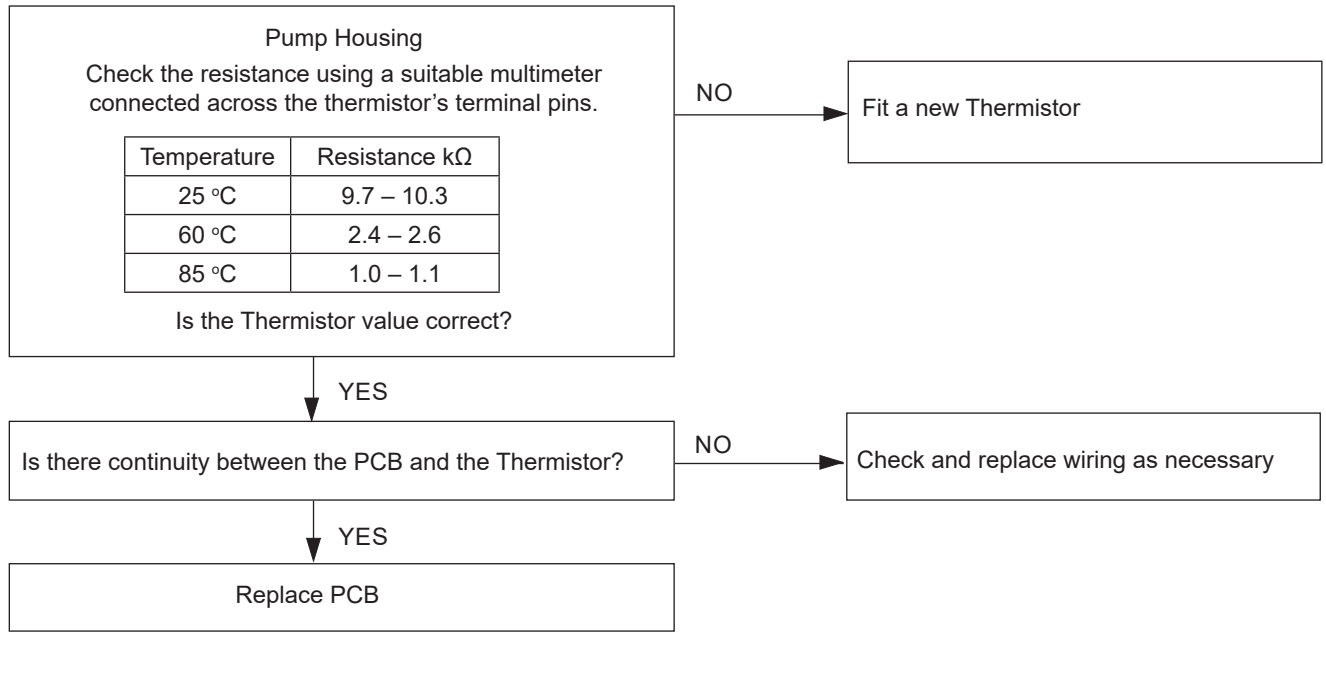

### 4.10 'F 06' - OUTSIDE SENSOR FAULT

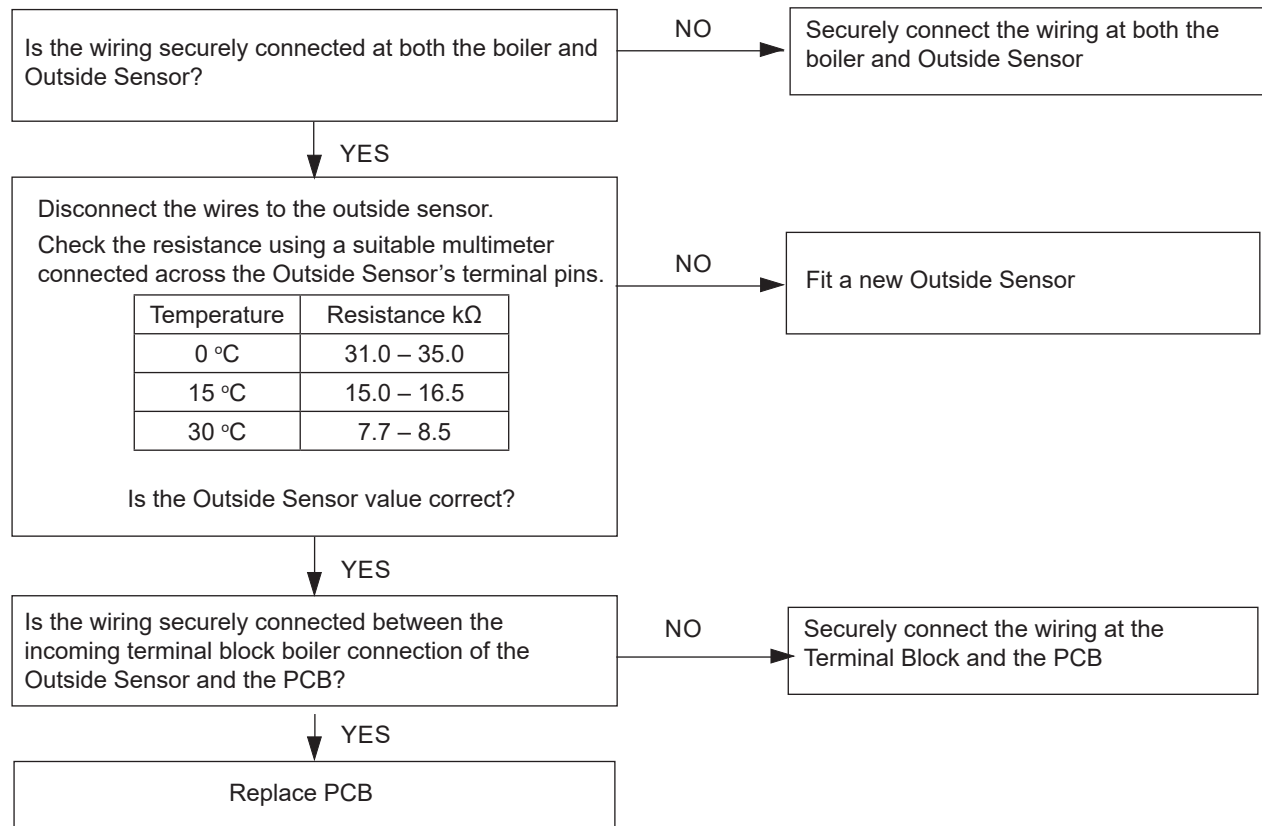

4.11 NO CH OPERATION BUT DHW WORKS OK

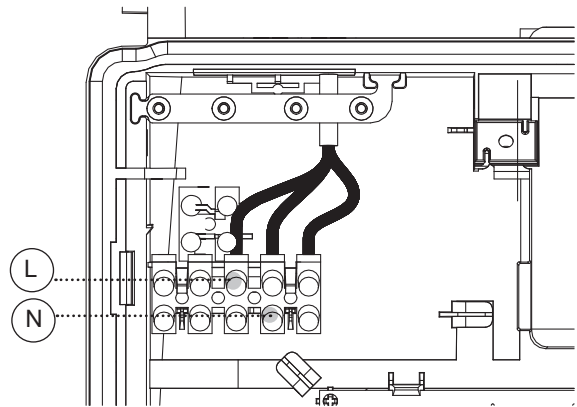
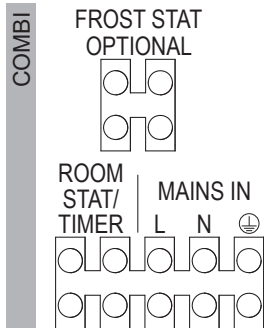
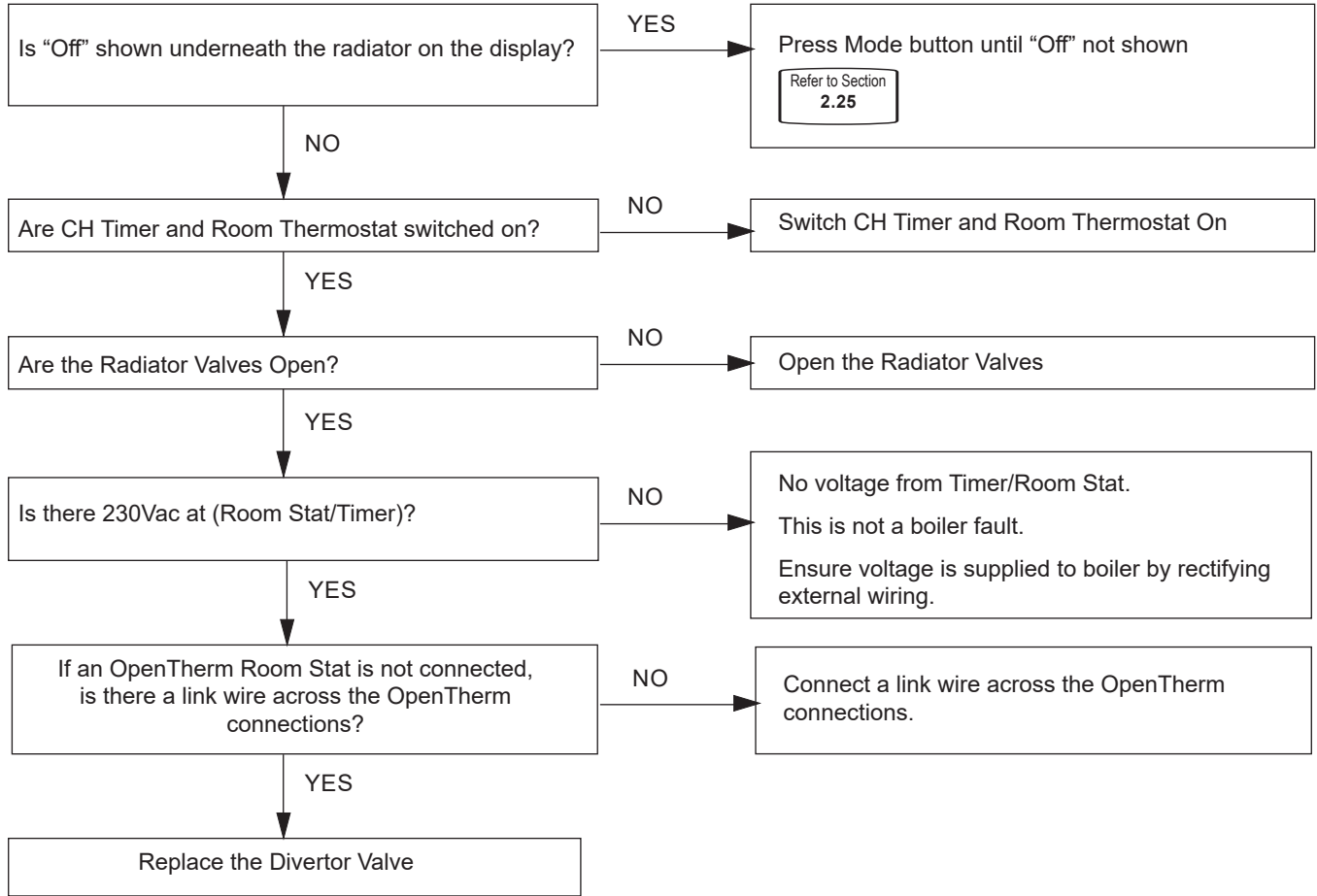

## 4.12 NO DHW BUT CH WORKS OK

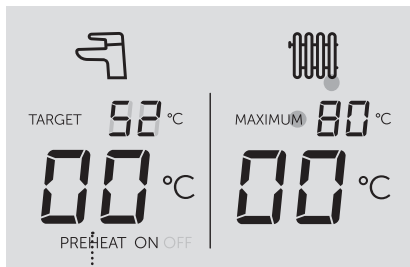
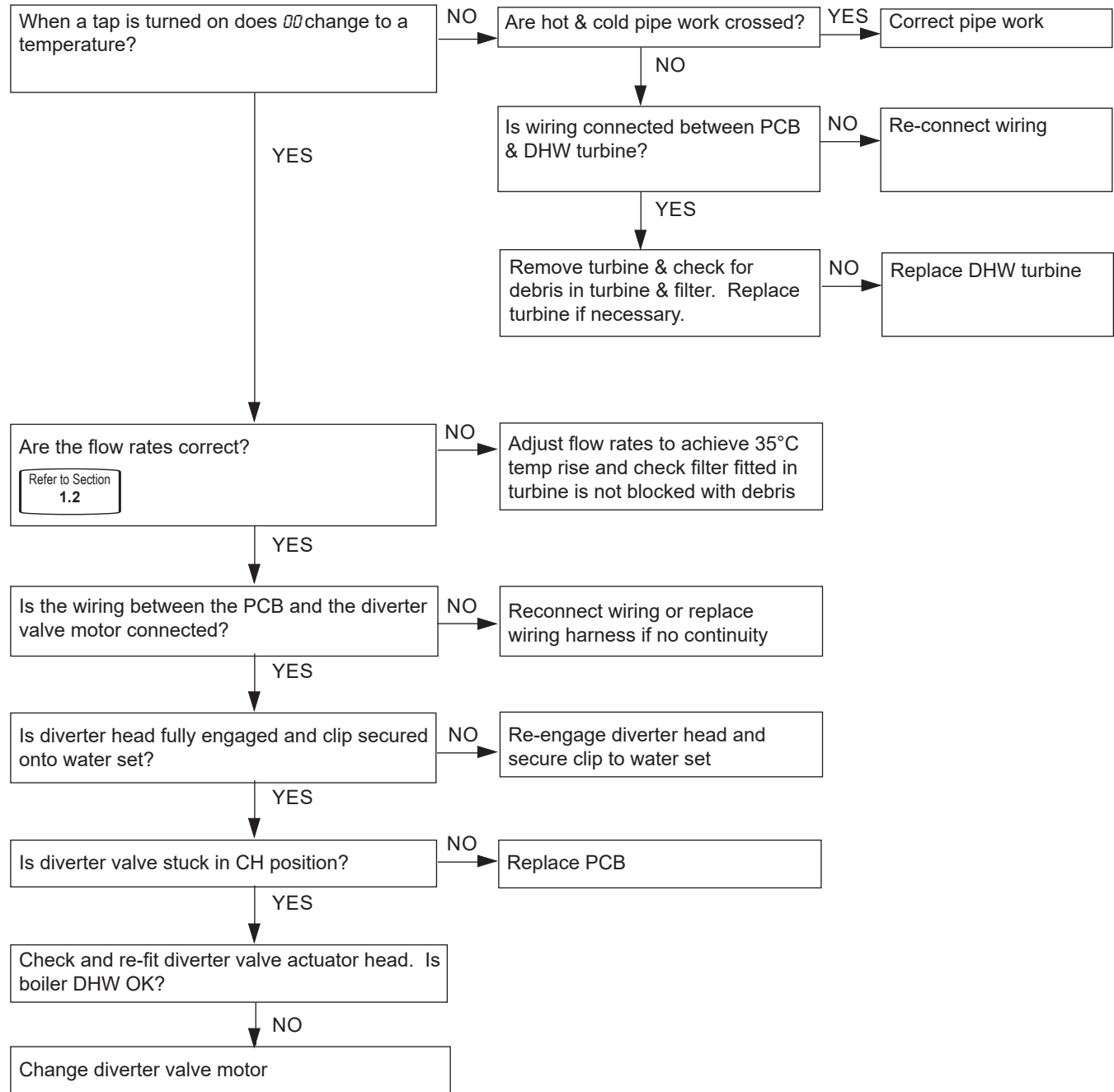

A

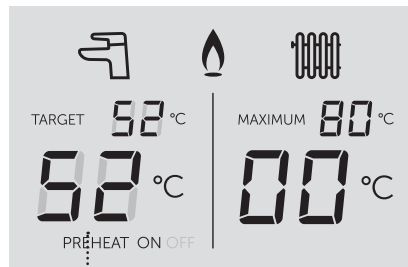

B

## 4.13 NO DISPLAY

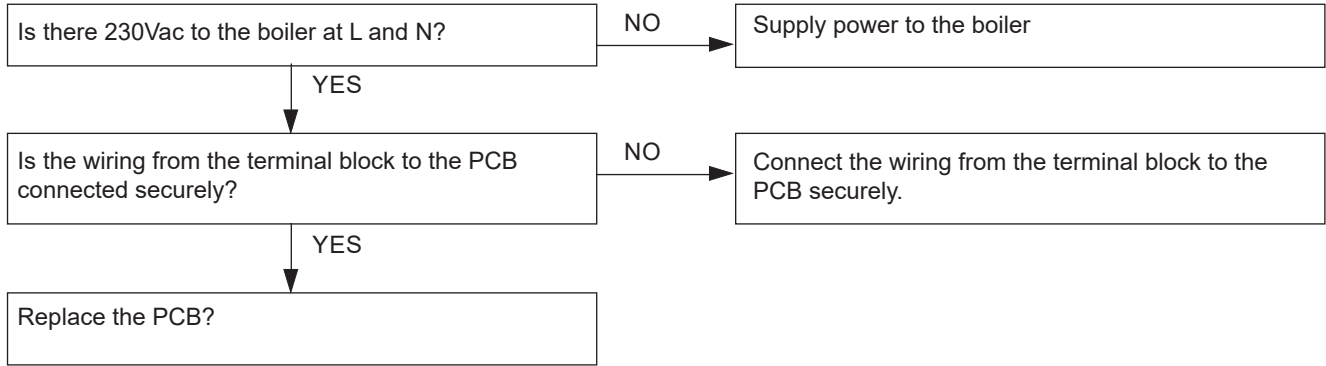

## 4.14 'F0U' FLOW/RETURN DIFFERENTIAL GREATER THAN 50°C

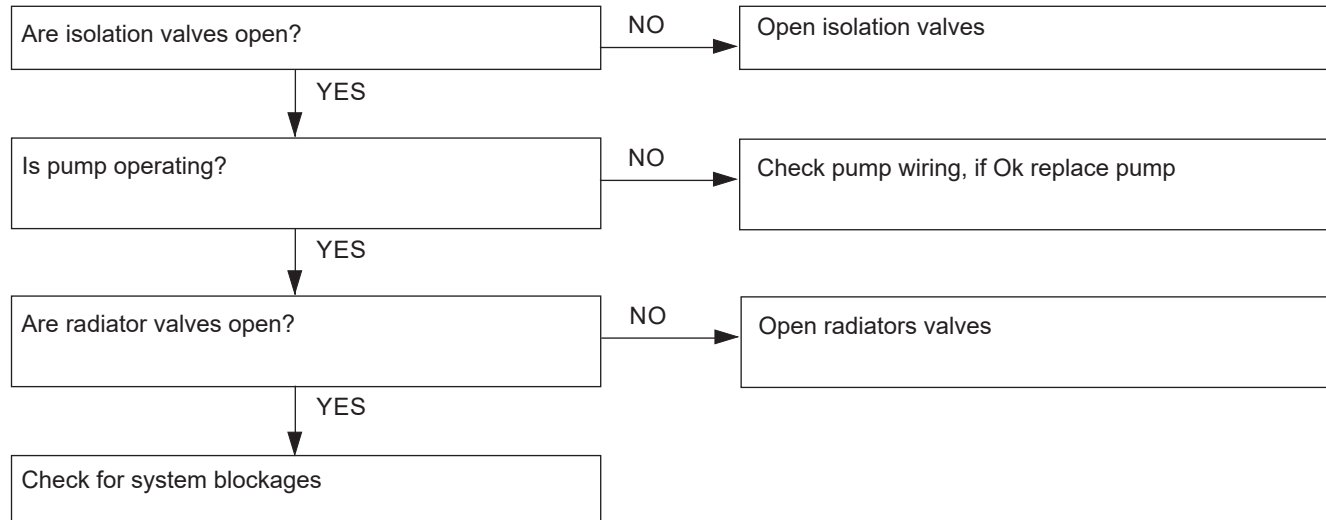

FAULT FINDING

## 4.15 F 0C' DHW THERMISTOR FAULT

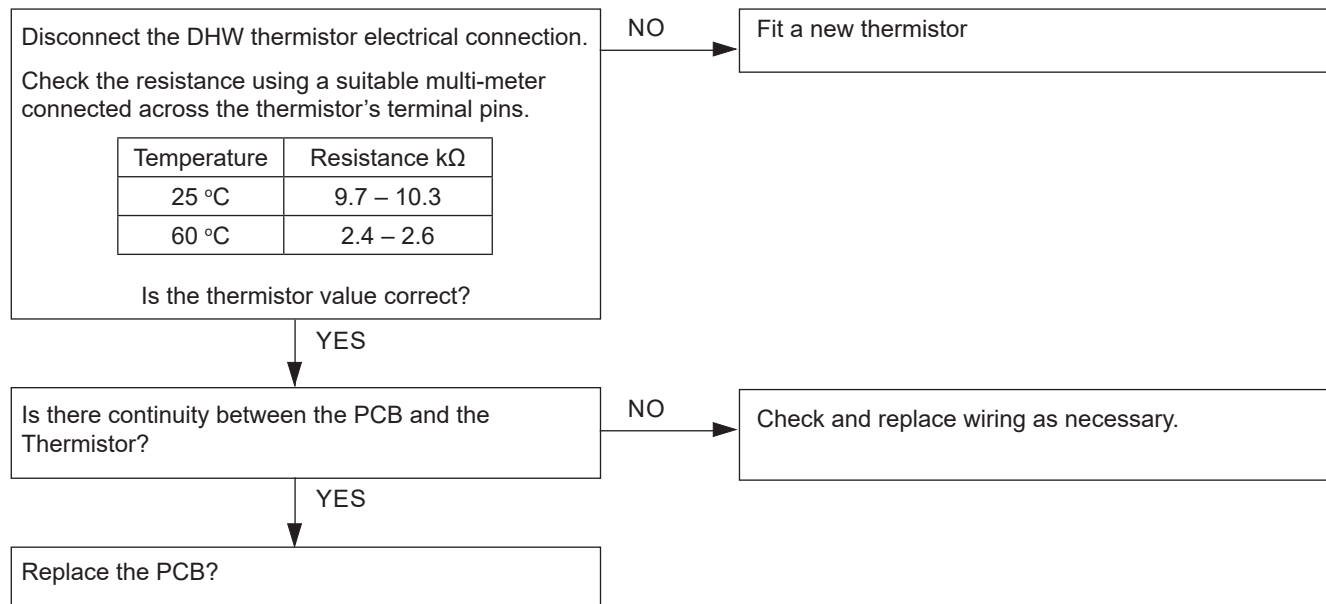

## Section 5 - Spare Parts

When replacing any part on this appliance use only spare parts that you can be assured conform to the safety and performance specification that we require. Do not use reconditioned or copy parts that have not been clearly authorised by Ideal.

Failure to do so could affect safety or performance of this appliance.

Comprehensive spares parts information and details of approved Ideal Parts Distributors are available on **idealparts.com**



**Our Parts team are also available to help with your Ideal Spare Parts enquiries on 01482 498665.**

When calling, and to ensure we can provide you with the most accurate parts information, please ensure you have the following to hand;

- Boiler Model
- Appliance GC Number
- Boiler Serial Number

# Code Of Practice

For the installation, commissioning and servicing of domestic heating and hot water products

Benchmark places responsibilities on both manufacturers and installers.\* The purpose is to ensure that customers\*\* are provided with the correct equipment for their needs, that it is installed, commissioned and serviced in accordance with the manufacturer's instructions by competent persons and that it meets the requirements of the appropriate Building Regulations. Installers are required to carry out work in accordance with the following:

### Standards of Work

- Be competent and qualified to undertake the work required.
- Install, commission, service and use products in accordance with the manufacturer's instructions provided.
- Ensure that where there is responsibility for design work, the installation is correctly sized and fit for purpose.
- Meet the requirements of the appropriate Building Regulations. Where this involves notifiable work be a member of a Competent Persons Scheme or confirm that the customer has notified Local Authority Building Control (LABC), prior to work commencing.
- Complete all relevant sections of the Benchmark Checklist/Service Record when carrying out commissioning or servicing of a product or system.
- Ensure that the product or system is left in a safe condition and, whenever possible, in good working order.
- Highlight to the customer any remedial or improvement work identified during the course of commissioning or servicing work.
- Refer to the manufacturer's helpline where assistance is needed.
- Report product faults and concerns to the manufacturer in a timely manner.

### Customer Service

- Show the customer any identity card that is relevant to the work being carried out prior to commencement or on request.
- Give a full and clear explanation/demonstration of the product or system and its operation to the customer.
- Hand over the manufacturer's instructions, including the Benchmark Checklist, to the customer on completion of an installation.
- Obtain the customer's signature, on the Benchmark Checklist, to confirm satisfactory demonstration and receipt of manufacturer's instructions.
- Advise the customer that regular product servicing is needed, in line with manufacturers' recommendations, to ensure that safety and efficiency is maintained.
- Respond promptly to calls from a customer following completion of work, providing advice and assistance by phone and, if necessary, visiting the customer.
- Rectify any installation problems at no cost to the customer during the installer's guarantee period.



\*The use of the word "installer" is not limited to installation itself and covers those carrying out installation, commissioning and/or servicing of heating and hot water products, or the use of supporting products (such as water treatment or test equipment).

\*\*Customer includes householders, landlords and tenants.

# Benchmark Commissioning & Warranty Validation Service Record

It is a requirement that the boiler is installed and commissioned to the manufacturers' instructions and the data fields on the commissioning checklist completed in full.

To instigate the boiler warranty the boiler needs to be registered with the manufacturer within one month of the installation. The warranty rests with the end-user (consumer), and they should be made aware it is ultimately their responsibility to register with the manufacturer, within the allotted time period.

It is essential that the boiler is serviced in line with the manufacturers' recommendations, at least annually. This must be carried out by a competent Gas Safe registered engineer. The service details should be recorded on the Benchmark Service and Interim Boiler Work Record and left with the householder. Failure to comply with the manufacturers' servicing instructions and requirements will invalidate the warranty.



[www.hhic.co.uk](http://www.hhic.co.uk)

**This Commissioning Checklist is to be completed in full by the competent person who commissioned the boiler as a means of demonstrating compliance with the appropriate Building Regulations and then handed to the customer to keep for future reference.**

Failure to install and commission according to the manufacturers' instructions and complete this Benchmark Commissioning Checklist will invalidate the warranty. This does not affect the customer's statutory rights.

\* All installations in England and Wales must be notified to Local Authority Building Control (LABC) either directly or through a Competent Persons Scheme. A Building Regulations Compliance Certificate will then be issued to the customer.

© Heating and Hotwater Industry Council (HHIC)



[www.centralheating.co.uk](http://www.centralheating.co.uk)

# Section 6 - Benchmark to Commissioning

## GAS BOILER SYSTEM COMMISSIONING CHECKLIST & WARRANTY VALIDATION RECORD

Address:															
Boiler make and model:															
Boiler serial number:															
Commissioned by (PRINT NAME):						Gas Safe registration number:									
Company name:						Telephone number:									
Company email:						Company address:									
										Commissioning date:					
Heating and hot water system complies with the appropriate Building Regulations?											Yes				
Optional: Building Regulations Notification Number (if applicable):															
Time, temperature control and boiler interlock provided for central heating and hot water											Yes				
Boiler Plus requirements (tick the appropriate box(s))															
Boiler Plus option chosen for combination boiler in ENGLAND						Weather compensation			Smart thermostat with automisation and optimisation						
						Load compensation			Flue Gas Heat Recovery						
Time and temperature control to hot water			Cylinder thermostat and programmer/timer						Combination boiler						
Zone valves		pre-existing		Fitted		Not required		Not required		Not required					
Thermostatic radiator valves		pre-existing		Fitted		Not required		Not required		Not required					
Automatic bypass to system		pre-existing		Fitted		Not required		Not required		Not required					
Underfloor heating		pre-existing		Fitted		Not required		Not required		Not required					
Water quality															
The system has been flushed, cleaned and a suitable inhibitor applied upon final fill, in accordance with BS7593 and boiler manufacturers' instructions											Yes				
What system cleaner was used?						Brand:			Product:						
What inhibitor was used?						Brand:			Product:						
Primary water system filter		pre-existing		Fitted		Not required		Not required		Not required					
CENTRAL HEATING MODE measure and record (as appropriate)															
Gas rate (for combination boilers complete DHW mode gas rate)				m <sup>3</sup> /hr		or		ft <sup>3</sup> /hr							
Central heating output left at factory settings?						Yes		No		No					
If no, what is the maximum central heating output selected?											kW				
Dynamic gas inlet pressure											mbar				
Central heating flow temperature											°C				
Central heating return temperature											°C				
System correctly balanced/rebalanced?											Yes				
COMBINATION BOILERS ONLY															
Is the installation in a hard water area (above 200ppm)?						Yes		No		No					
Water scale reducer/softener		pre-existing		Fitted		Not required		Not required		Not required					
What type of scale reducer/softener has been fitted?						Brand:			Product:						
Water meter fitted?						Yes		No		No					
If yes- DHW expansion vessel		pre-existing		Fitted		Not required		Not required		Not required					
Pressure reducing valve		pre-existing		Fitted		Not required		Not required		Not required					
DOMESTIC HOT WATER MODE Measure and record															
Gas rate				m <sup>3</sup> /hr		or		ft <sup>3</sup> /hr							
Dynamic gas inlet pressure at maximum rate											mbar				
Cold water inlet temperature											°C				
Hot water has been checked at all outlets						Yes		Temperature		°C					
CONDENSATE DISPOSAL															
The condensate drain has been installed in accordance with the manufacturers' instructions and/or BS5546/BS6798											Yes				
Point of termination						Internal		External (only where internal termination impractical)							
Method of disposal						Gravity		Pumped							
ALL INSTALLATIONS															
Record the following		At max rate:		CO		ppm		CO <sub>2</sub>		%		CO/CO <sub>2</sub>		Ratio	
		At min rate (where possible)		CO		ppm		CO <sub>2</sub>		%		CO/CO <sub>2</sub>		Ratio	
Where possible, has a flue integrity check been undertaken in accordance with manufacturers' instructions, and readings are correct?											Yes				
The operation of the boiler and system controls have been demonstrated to and understood by the customer											Yes				
The manufacturers' literature, including Benchmark Checklist and Service Record, has been explained and left with the customer											Yes				
Commissioning Engineer's signature															
Customer's signature (To confirm satisfactory demonstration and receipt of manufacturers' literature)															

\* All installations in England and Wales must be notified to Local Authority Building Control (LABC) either directly or through a Competent Persons Scheme. A Building Regulations Compliance Certificate will then be issued to the customer.

© Heating and Hotwater Industry Council (HHIC)



www.centralheating.co.uk

# Section 6 - Benchmark to Commissioning

## SERVICE & INTERIM BOILER WORK RECORD

It is recommended that your boiler and heating system are regularly serviced and maintained, in line with manufacturers' instructions, and that the appropriate service / interim work record is completed.

### Service provider

When completing a service record (as below), please ensure you have carried out the service as described in the manufacturers' instructions. Always use the manufacturers' specified spare parts.

SERVICE/INTERIM WORK ON BOILER <small>delete as appropriate</small>					Date:
Engineer name:		Company name:			
Telephone N°:		Gas Safe registration N°:			
Max rate	CO	ppm	CO <sub>2</sub>	%	CO/CO <sub>2</sub>
Min rate	CO	ppm	CO <sub>2</sub>	%	CO/CO <sub>2</sub>
Where possible, has a flue integrity check been undertaken in accordance with manufacturers' instructions, and readings are correct?*					yes
Gas rate:	m <sup>3</sup> /h	OR	ft <sup>3</sup> /h		
Were parts fitted? <small>delete as appropriate</small>		Yes	No		
Parts fitted:					
System inhibitor concentration has been checked and appropriate action taken, in accordance with BS 7593 and boiler manufacturers' instructions. *					yes
					n/a
Comments:					
Signature:					

\*A System inhibitor efficacy test is required on every annual service in accordance with the manufacturers' instructions and BS 7593. It is only acceptable to not have undertaken this if the service engineers attendance visit was in between annual services to attend a non-water facing component.

SERVICE/INTERIM WORK ON BOILER <small>delete as appropriate</small>					Date:
Engineer name:		Company name:			
Telephone N°:		Gas Safe registration N°:			
Max rate	CO	ppm	CO <sub>2</sub>	%	CO/CO <sub>2</sub>
Min rate	CO	ppm	CO <sub>2</sub>	%	CO/CO <sub>2</sub>
Where possible, has a flue integrity check been undertaken in accordance with manufacturers' instructions, and readings are correct?*					yes
Gas rate:	m <sup>3</sup> /h	OR	ft <sup>3</sup> /h		
Were parts fitted? <small>delete as appropriate</small>		Yes	No		
Parts fitted:					
System inhibitor concentration has been checked and appropriate action taken, in accordance with BS 7593 and boiler manufacturers' instructions. *					yes
					n/a
Comments:					
Signature:					

\*A System inhibitor efficacy test is required on every annual service in accordance with the manufacturers' instructions and BS 7593. It is only acceptable to not have undertaken this if the service engineers attendance visit was in between annual services to attend a non-water facing component.

SERVICE/INTERIM WORK ON BOILER <small>delete as appropriate</small>					Date:
Engineer name:		Company name:			
Telephone N°:		Gas Safe registration N°:			
Max rate	CO	ppm	CO <sub>2</sub>	%	CO/CO <sub>2</sub>
Min rate	CO	ppm	CO <sub>2</sub>	%	CO/CO <sub>2</sub>
Where possible, has a flue integrity check been undertaken in accordance with manufacturers' instructions, and readings are correct?*					yes
Gas rate:	m <sup>3</sup> /h	OR	ft <sup>3</sup> /h		
Were parts fitted? <small>delete as appropriate</small>		Yes	No		
Parts fitted:					
System inhibitor concentration has been checked and appropriate action taken, in accordance with BS 7593 and boiler manufacturers' instructions. *					yes
					n/a
Comments:					
Signature:					

\*A System inhibitor efficacy test is required on every annual service in accordance with the manufacturers' instructions and BS 7593. It is only acceptable to not have undertaken this if the service engineers attendance visit was in between annual services to attend a non-water facing component.

SERVICE/INTERIM WORK ON BOILER <small>delete as appropriate</small>					Date:
Engineer name:		Company name:			
Telephone N°:		Gas Safe registration N°:			
Max rate	CO	ppm	CO <sub>2</sub>	%	CO/CO <sub>2</sub>
Min rate	CO	ppm	CO <sub>2</sub>	%	CO/CO <sub>2</sub>
Where possible, has a flue integrity check been undertaken in accordance with manufacturers' instructions, and readings are correct?*					yes
Gas rate:	m <sup>3</sup> /h	OR	ft <sup>3</sup> /h		
Were parts fitted? <small>delete as appropriate</small>		Yes	No		
Parts fitted:					
System inhibitor concentration has been checked and appropriate action taken, in accordance with BS 7593 and boiler manufacturers' instructions. *					yes
					n/a
Comments:					
Signature:					

\*A System inhibitor efficacy test is required on every annual service in accordance with the manufacturers' instructions and BS 7593. It is only acceptable to not have undertaken this if the service engineers attendance visit was in between annual services to attend a non-water facing component.

SERVICE/INTERIM WORK ON BOILER <small>delete as appropriate</small>					Date:
Engineer name:		Company name:			
Telephone N°:		Gas Safe registration N°:			
Max rate	CO	ppm	CO <sub>2</sub>	%	CO/CO <sub>2</sub>
Min rate	CO	ppm	CO <sub>2</sub>	%	CO/CO <sub>2</sub>
Where possible, has a flue integrity check been undertaken in accordance with manufacturers' instructions, and readings are correct?*					yes
Gas rate:	m <sup>3</sup> /h	OR	ft <sup>3</sup> /h		
Were parts fitted? <small>delete as appropriate</small>		Yes	No		
Parts fitted:					
System inhibitor concentration has been checked and appropriate action taken, in accordance with BS 7593 and boiler manufacturers' instructions. *					yes
					n/a
Comments:					
Signature:					

\*A System inhibitor efficacy test is required on every annual service in accordance with the manufacturers' instructions and BS 7593. It is only acceptable to not have undertaken this if the service engineers attendance visit was in between annual services to attend a non-water facing component.

SERVICE/INTERIM WORK ON BOILER <small>delete as appropriate</small>					Date:
Engineer name:		Company name:			
Telephone N°:		Gas Safe registration N°:			
Max rate	CO	ppm	CO <sub>2</sub>	%	CO/CO <sub>2</sub>
Min rate	CO	ppm	CO <sub>2</sub>	%	CO/CO <sub>2</sub>
Where possible, has a flue integrity check been undertaken in accordance with manufacturers' instructions, and readings are correct?*					yes
Gas rate:	m <sup>3</sup> /h	OR	ft <sup>3</sup> /h		
Were parts fitted? <small>delete as appropriate</small>		Yes	No		
Parts fitted:					
System inhibitor concentration has been checked and appropriate action taken, in accordance with BS 7593 and boiler manufacturers' instructions. *					yes
					n/a
Comments:					
Signature:					

\*A System inhibitor efficacy test is required on every annual service in accordance with the manufacturers' instructions and BS 7593. It is only acceptable to not have undertaken this if the service engineers attendance visit was in between annual services to attend a non-water facing component.

\* All installations in England and Wales must be notified to Local Authority Building Control (LABC) either directly or through a Competent Persons Scheme. A Building Regulations Compliance Certificate will then be issued to the customer.

© Heating and Hotwater Industry Council (HHIC)



www.centralheating.co.uk

## FLOWCHART FOR CO LEVEL AND COMBUSTION RATIO CHECK ON COMMISSIONING A CONDENSING BOILER

### Important Preliminary Information on Checks

The air gas ratio valve is factory-set and must not be adjusted DURING COMMISSIONING.

If the boiler requires conversion to operate with a different gas family (e.g. conversion from natural gas to LPG) separate guidance is provided with the conversion kit supplied and this must be followed.

#### PRIOR TO CO LEVEL AND COMBUSTION RATIO CHECK

The installation instructions must have been followed, gas type verified and gas supply pressure / gas rate checked as required prior to commissioning.

As part of the installation process, ESPECIALLY WHERE A FLUE HAS BEEN FITTED BY PERSONS OTHER THAN THE BOILER INSTALLER, visually check the integrity of the whole flue system to confirm that all components are correctly assembled, fixed and supported. Check that maximum flue lengths have not been exceeded and all guidance has been followed (e.g. Gas Safe Register Technical Bulletin (TB) 008 where chimney/flues are in voids).

The ECGA should be of the correct type, as specified by BS EN 50379-3:2012.

Prior to its use, the ECGA should have been maintained and calibrated as specified by the manufacturer. The installer must have the relevant competence for use of the analyser.

Check and zero the analyser IN FRESH AIR in accordance with the analyser manufacturer's instructions.

KEY:

**CO** = carbon monoxide

**CO<sub>2</sub>** = carbon dioxide

**O<sub>2</sub>** = oxygen

**Combustion Ratio** = The CO reading measured in ppm divided by the CO<sub>2</sub> reading first converted to ppm

**ppm** = parts per million

**GS(I&U)R** = Gas Safety (Installation and Use) Regulations

**IMPORTANT:** Ensure boiler is in normal operation with a heat demand before setting Maximum / Minimum rate function.

#### Setting to Maximum Rate:

1. Hold "MODE" & "RESTART" buttons together for more than 5s
2. Last 3 faults will be shown
3. SH shown, press "RESTART" button
4. Burner will run for 10 minutes at maximum rate
5. Press "RESTART" to exit Maximum Rate mode

#### Setting to Minimum Rate:

1. Hold "MODE" & "RESTART" buttons together for more than 5s
2. Last 3 faults will be shown
3. SH shown, press "MODE" button
4. SL shown, press "RESTART"
5. If the return temperature is under 40°C then the fan will run for 30s at maximum rate before ramping down over 60s to minimum rate.
6. Burner will run for 10 minutes at minimum rate
7. Press "RESTART" to exit Minimum Rate mode

 **IMPORTANT:** Do not disconnect the boiler's mains power while it is in service mode (maximum/minimum rate).

If the boiler is turned off while in service mode, it will automatically resume the interrupted service mode when powered back on and will complete after 10 minutes.

To manually finish the service mode, wait at least 60 seconds after an electrical supply has been reconnected, then begin the service mode setup procedure again and exit as the instruction provided.

## Section 6 - Benchmark to Commissioning

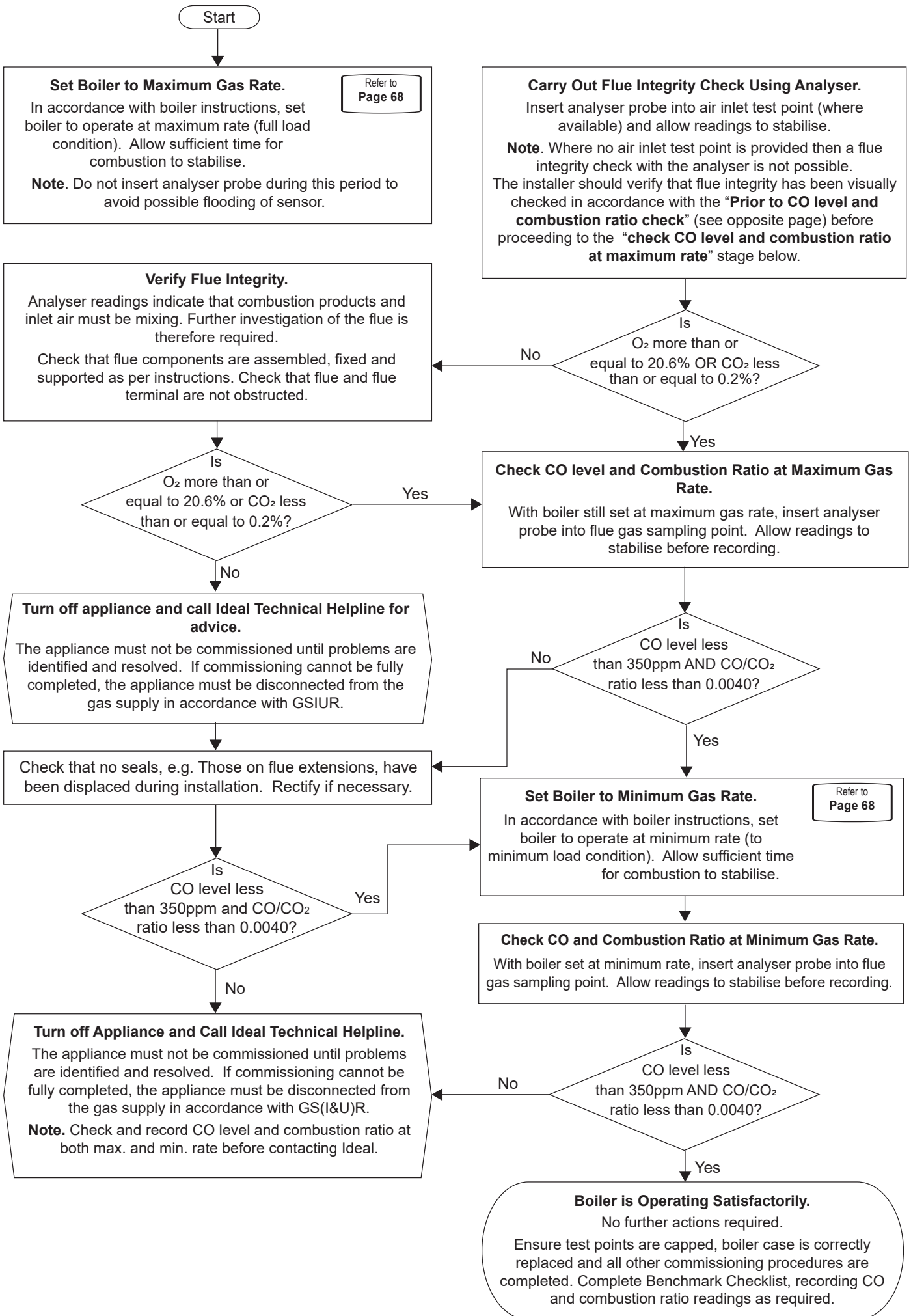

## Notes

# Notes

## Notes

# Notes



At Ideal Heating we take our environmental impact seriously, therefore when installing any Ideal Heating product please make sure to dispose of any previous appliance in an environmentally conscious manner. Households can contact their local authority to find out how. See <https://www.gov.uk/managing-your-waste-an-overview> for guidance on how to efficiently recycle your business waste.

### *Technical Training*

Our Expert Academy offer a range of training options designed and delivered by our experts in heating. For details please contact: [expert-academy.co.uk](http://expert-academy.co.uk)

Ideal Boilers Ltd., pursues a policy of continuing improvement in the design and performance of its products. The right is therefore reserved to vary specification without notice.

Ideal is a trademark of Ideal Boilers.

Registered Office

Ideal Boilers Ltd., National Avenue, Hull, East Yorkshire, HU5 4JB

Tel 01482 492251 Fax 01482 448858

Registration No. London 322 137

EU Authorised Representative:

Atlantic SFDT

44 Boulevard des Etats-Unis, 85 000 La Roche-Sur-Yon, France

+33 (0)2 51 44 34 34

Ideal Technical Helpline: 01482 498663

Ideal Consumer Helpline: 01482 498660

Ideal Parts: 01482 498665

[idealheating.com](http://idealheating.com)

**ideal**  
HEATING