

**ideal**  
HEATING

# INSTALLATION & SERVICING

**LOGIC CODE COMBI ESP1  
26 33 38**

When replacing any part on this appliance, use only spare parts that you can be assured conform to the safety and performance specification that we require. Do not use reconditioned or copy parts that have not been clearly authorised by Ideal Heating.

For the very latest copy of literature for specification and maintenance practices visit our website [idealheating.com](http://idealheating.com) where you can download the relevant information in PDF format.



**ERP DATA**

	SYMBOL	UNITS	MODEL		
			26	33	38
Condensing Boiler	n/a	n/a	yes	yes	yes
Low Temperature Boiler	n/a	n/a	no	no	no
B1 Boiler	n/a	n/a	no	no	no
Cogeneration Space Heater	n/a	n/a	no	no	no
Equipped with a Supplementary Heater	n/a	n/a	no	no	no
Combination Heater	n/a	n/a	yes	yes	yes
<b>Nominal Heat Output for Space Heating</b>					
Full Load	P <sub>4</sub>	kW	24.3	24.3	24.3
Part Load	P <sub>1</sub>	kW	8.0	8.0	8.0
<b>Auxiliary Electricity Consumption</b>					
Full Load	e <sub>lmax</sub>	kW	0.034	0.041	0.041
Part Load	e <sub>lmin</sub>	kW	0.010	0.014	0.015
Standby	P <sub>SB</sub>	kW	0.003	0.003	0.003
<b>Seasonal Space Heating Energy Efficiency</b>					
Full Load	η <sub>4</sub>	%	90.0	90.0	90.0
Part Load	η <sub>1</sub>	%	98.7	98.7	98.7
Standby Loss	P <sub>stby</sub>	kW	0.050	0.050	0.050
Ignition	P <sub>ign</sub>	kW	0	0	0
<b>Emissions</b>					
Nox (Gross)	NO <sub>x, pond Hs</sub>	mg/kWh	24	25	32
Annual Energy Consumption	Q <sub>HE</sub>	GJ	75	75	75
Sound Power Level, Indoors	L <sub>WA</sub>	dB	49	47	44
<b>Domestic Hot Water</b>					
Domestic Hot Water	Q <sub>elec</sub>	kWh	0.157	0.150	0.153
Water heating energy efficiency (Eco) Tapping Profile XL	η <sub>WH</sub>	%	90	89	90
Daily fuel consumption 24hr (GCV) Actual measured	Q <sub>fuel</sub>	kWh	21.272	21.536	21.418
Annual electricity consumption	AEC	kWh	34	33	33
Annual fuel consumption	AFC	GJ	16	17	16

# PRODUCT FICHE

## LOGIC CODE COMBI ESP1 COMBINATION BOILER

Ideal Heating

### ERP DATA

	SYMBOL	UNITS	MODEL		
			26	33	38
Condensing boiler			Yes		
Seasonal Space heating efficiency class			A		
Rated heat output		kW	24		
Seasonal space heating energy efficiency	$\eta_s$	%	94*		
Annual energy consumption	$Q_{HE}$	GJ	75		
Sound power level, indoors	$L_{WA}$	dB	49	47	44
Water heating energy efficiency class			A		

<b>Seasonal Space Heating Energy Efficiency of the Boiler</b>								*%	<b>A</b>
<b>Temperature control (from fiche of temperature control)</b>								%	
<i>Class I</i>	<i>Class II</i>	<i>Class III</i>	<i>Class IV</i>	<i>Class V</i>	<i>Class VI</i>	<i>Class VII</i>	<i>Class VIII</i>	<b>B</b>	
1%	2%	1.5%	2%	3%	4%	3.5%	5%		

### Solar Contribution (from fiche of solar device)

Collector Size  
(in m<sup>2</sup>)

Tank Volume  
(in m<sup>3</sup>)

Collector Efficiency  
(in %)

Tank rating  
A\* = 0.95  
A = 0.91  
B = 0.86  
C = 0.83  
D-G = 0.81

= ('III' x  + 'IV' x  ) x 0.9 x (  / 100 x  ) = % **C**

**Seasonal Space Heating Energy Efficiency of Package**

**TOTAL: A+B+C=**

%

### Seasonal Space Heating Energy Efficiency Class of Package

<input style="width: 30px; height: 20px;" type="text"/>	<input style="width: 30px; height: 20px;" type="text"/>	<input style="width: 30px; height: 20px;" type="text"/>	<input style="width: 30px; height: 20px;" type="text"/>	<input style="width: 30px; height: 20px;" type="text"/>	<input style="width: 30px; height: 20px;" type="text"/>	<input style="width: 30px; height: 20px;" type="text"/>	<input style="width: 30px; height: 20px;" type="text"/>	<input style="width: 30px; height: 20px;" type="text"/>	<input style="width: 30px; height: 20px;" type="text"/>
<b>G</b>	<b>F</b>	<b>E</b>	<b>D</b>	<b>C</b>	<b>B</b>	<b>A</b>	<b>A+</b>	<b>A++</b>	<b>A+++</b>
< 30%	≥ 30%	≥ 34%	≥ 36%	≥ 75%	≥ 82%	≥ 90%	≥ 98%	≥ 125%	≥ 150%

The energy efficiency of the package of products provided for in this document may not correspond to its actual energy efficiency once installed in a building, as the efficiency is influenced by further factors such as heat loss in the products in relation to the building size and its characteristics



## NOTES FOR THE INSTALLER

**FOR ANY TECHNICAL QUERIES PLEASE RING THE IDEAL  
INSTALLER HELPLINE : 01482 498704**

**NOTE. BOILER RESTART PROCEDURE -**

To restart the boiler press the RESTART button. The boiler will repeat the ignition sequence if a heat demand is present.

## DOCUMENT AMENDMENTS

Relevant Installation changes implemented in this book from Mod Level ..... A04 (Jul 24) to A05 (Jul 25)

**Section 1.17 BOILER DIMENSIONS, SERVICES & CLEARANCES**

Updated images - Page 14



# CONTENTS

<b>1</b>	<b>GENERAL</b> .....	<b>10</b>	<b>3</b>	<b>SERVICING</b> .....	<b>39</b>
1.1	Introduction .....	10	3.1	Servicing Schedule .....	39
1.2	Operation .....	10	3.2	Top Pod Door & Front Panel Removal/Replacement ...	40
1.3	Safe Handling.....	10	3.3	Fan And Venturi Assembly Removal And Cleaning....	40
1.4	Optional Extra Kits .....	11	3.4	Burner Removal And Cleaning.....	41
1.5	Safety .....	11	3.5	Cleaning The Condensate Trap/Siphon .....	41
1.6	Safe Handling Of Substances .....	11	3.6	Cleaning The Heat Exchanger .....	42
1.7	Location Of Boiler .....	11	3.7	Reassembly .....	42
1.8	Carbon Monoxide Alarms .....	11	3.8	Replacement Of Components.....	43
1.9	Gas Supply.....	12	3.9	Fan Replacement.....	43
1.10	Flue Installation .....	12	3.10	Burner Injector Replacement .....	44
1.11	Terminal.....	13	3.11	Burner Replacement .....	44
1.12	Air Supply.....	13	3.12	Return Thermistor Renewal .....	45
1.13	Water Circulation System.....	13	3.13	Ignition Electrode Replacement .....	45
1.14	Boiler Control Interlocks.....	13	3.14	Flame Detection Electrode Replacement.....	46
1.15	Electrical Supply.....	13	3.15	Spark Generator Replacement .....	46
1.16	Condensate Drain .....	13	3.16	Gas Control Valve Replacement.....	46
1.17	Boiler Dimensions, Services & Clearances.....	14	3.17	Diverter Valve Actuator Replacement .....	47
1.18	System Requirements - Central Heating.....	15	3.18	Condensate Trap/Siphon Replacement .....	47
1.19	System Balancing .....	16	3.19	PCB Replacement.....	48
1.20	Water Treatment.....	16	3.20	Dhw Flow Turbine Sensor Replacement.....	48
<b>2</b>	<b>INSTALLATION</b> .....	<b>17</b>	3.21	Draining The Boiler .....	49
2.1	Boiler Assembly - Exploded View.....	17	3.22	Pressure Gauge Replacement.....	49
2.2	Unpacking .....	18	3.23	Safety Relief Valve Renewal .....	50
2.3	Pod Door & Front Panel Removal.....	19	3.24	Pump Automatic Air Vent Replacement .....	50
2.4	Wall Mounting Template .....	20	3.25	DHW Filter & Flow Regulator Cleaning/Replacement ...	50
2.5	Preparing The Wall.....	20	3.26	Diverter Valve Body Assembly Replacement .....	51
2.6	Fitting The Wall Mounting Plate .....	20	3.27	Dhw Plate Heat Exch. Replacement.....	51
2.7	Mounting The Boiler .....	20	3.28	Pump Head Replacement.....	51
2.8	Determining The Flue Length & Flue Packs Rq'd .....	21	3.29	Ch Water Pressure Switch Replacement.....	52
2.9	Cutting & Setting The Flue Length .....	23	3.30	Flow Thermistor Replacement .....	52
2.10	Installing The Flue.....	24	3.31	Heat Engine Renewal .....	53
2.11	Fitting The Optional Roof Flue Kit (Flat Or Pitched)...	25	3.32	Expansion Vessel Recharging & Replacement.....	54
2.12	Flue Terminal Position.....	26	3.33	Recuperator Replacement & Cleaning.....	55
2.13	Assembling The Roof Flue Kit.....	27	<b>4</b>	<b>FAULT FINDING</b> .....	<b>55</b>
2.14	Condensate Drain .....	28	4.1	Fault Finding Chart Main Menu .....	56
2.15	Connections & Filling .....	30	4.2	'L1' - Flow Temperature Overheat Lockout .....	57
2.16	Electrical Connections.....	32	4.3	'L2' - Ignition Lockout .....	57
2.17	Installer Wiring .....	32	4.4	'L6' - False Flame Lockout .....	58
2.18	External Wiring.....	33	4.5	'F1' - Low Water Pressure.....	58
2.19	Replacing Pre-Fitted Mains Cable .....	33	4.6	'F2 Or Fn Or Ln' - Flame Loss.....	58
2.20	Wiring Diagram .....	34	4.7	'F3' - Fan Fault .....	59
2.21	Commissioning And Testing .....	35	4.8	'F4 Or L4' - Flow Thermistor Fault.....	59
2.22	Initial Lighting .....	36	4.9	'F5 Or L5' - Return Thermistor Fault .....	59
2.23	General Checks .....	37	4.10	'F6' - Outside Sensor Fault.....	60
2.24	Restart Procedure .....	38	4.11	No Ch Operation But Hw Works Ok.....	60
2.25	Accessing The Installer Mode .....	38	4.12	No Hw But Ch On.....	61
2.26	Handing Over .....	38	4.13	No Display.....	61
			<b>5</b>	<b>SPARE PARTS</b> .....	<b>61</b>
			<b>6</b>	<b>BENCHMARK &amp; COMMISSIONING</b> .....	<b>63</b>

## SECTION 1 - GENERAL

**Table 1 - General Data**

		26	33	38
Gas supply		2H - G20 - 20mbar		
Gas Supply Connection		15mm copper compression		
Injector Size	mm	4.15	4.65	4.9
Inlet Connection	DHW	15mm copper compression		
Outlet Connection	DHW	15mm copper compression		
Flow Connection	Central Heating	22mm copper compression		
Return Connection	Central Heating	22mm copper compression		
Flue Terminal Diameter	mm	100		
Average Flue Temp-Mass Flow Rate	(DHW)	30°C 11g/s	32°C 13g/s	35°C 15g/s
Average Flue Temp-Mass Flow Rate	(CH)	63°C 11g/s	68°C 13g/s	73°C 13g/s
CO <sub>2</sub> Content (± 0.7)	Max. DHW	9.2%	9.2%	10.1%
	Max. CH	9.2%	9.4%	10%
	Min.	8.7%	8.4%	8.8%
Maximum Working Pressure (Sealed Systems)	bar	2.5		
Maximum Domestic Hot Water Inlet Pressure	bar	10.0		
Minimum Domestic Hot Water Inlet Pressure*	bar	1.1	1.6	1.9
Electrical Supply		230 V ~ 50 Hz.		
Power Consumption	W	86	93	93
Fuse Rating		External : 3A Internal : T4A HRC L250 V		
Water content	CH litre	1.2		
	DHW litre	1.0		
Packaged Weight	kg	38.05	38.15	38.35
Maximum Installation Weight	kg	32.65	32.75	32.95
Boiler Casing Size	Height mm	826		
	Width mm	395		
	Depth mm	278		

\*Required for maximum flow rate. Boiler operates down to 2 l/min DHW delivery

\*\* In areas of low water pressure the DHW restrictor can be removed

**Table 2 - Performance Data - Central Heating**

Boiler Input:		Max.	Min.		
			26	33	38
Boiler Input 'Q'	Nett CV kW	24.3	4.9	6.1	7.1
	Gross CV kW	27.0	5.4	6.7	7.9
	Gas Consumption m <sup>3</sup> /h	2.51	0.50	0.62	0.73
Boiler Output:					
Non Condensing	kW	24.2	4.8	6.1	7.1
70°C Mean Water Temp.					
Condensing	kW	25.6	5.1	6.4	7.5
40°C Mean Water Temp.					
Seasonal Efficiency*	SED Buk 2005	91.1%	91.1%	91.1%	
	SED Buk 2009	89.6%	89.6%	89.6%	
NOx Classification		CLASS 6			
NOx Level (mg/kWh @ 0% O <sub>2</sub> )		26.4	28.1	35.3	

\* The value is used in the UK Government's Standard Assessment Procedure (SAP) for energy rating of dwellings. The test data from which it has been calculated have been certified by a notified body.

**Note.** Gas consumption is calculated using a calorific value of 38.7 MJ/m<sup>3</sup> (1038 Btu/ft<sup>3</sup>) gross or 34.9 MJ/m<sup>3</sup> (935 Btu/ft<sup>3</sup>) nett.

To obtain the gas consumption at a different calorific value:

- For l/s - divide the gross heat input (kW) by the gross C.V. of the gas (MJ/m<sup>3</sup>)
- For Btu/h - multiply the gross heat input (kW) by 26.8
- For ft<sup>3</sup>/h - divide the gross heat input (Btu/h) by the gross C.V. of the gas (Btu/ft<sup>3</sup>)
- For m<sup>3</sup>/h - multiply l/s by 36

**Table 3 - Performance Data - Domestic Hot Water**

Maximum DHW Input :	26	33	38	
Nett CV kW	24.3	30.4	35.4	
Gross CV kW	27.0	33.7	39.3	
Gas Consumption m <sup>3</sup> /h	2.51	3.14	3.66	
	(ft <sup>3</sup> /h)	(89)	(111)	(129)
Maximum DHW Output kW	26.1	32.7	38.2	
DHW Flow Rate at 35°C temp. rise	l/min	10.7	13.4	15.7
DHW Specific Rate	l/min	12.5	15.6	18.3

### Key to symbols

**GB** = United Kingdom **IE** = Ireland (Countries of destination)

**PMS** = Maximum operating pressure of water

**C<sub>13</sub> C<sub>33</sub> C<sub>53</sub>** = A room sealed appliance designed for connection via ducts to a horizontal or vertical terminal, which admits fresh air to the burner and discharges the products of combustion to the outside through orifices which, in this case, are concentric. The fan is up stream of the combustion chamber.

**I<sub>2H</sub>** = An appliance designed for use on 2nd Family gas, Group H only.

**LOGIC CODE COMBI ESP1**

Natural Gas only

Boiler size	G.C. Appliance No. (Benchmark No.)
26	47-349-35
33	47-349-36
38	47-349-37

Destination Country: GB, IE

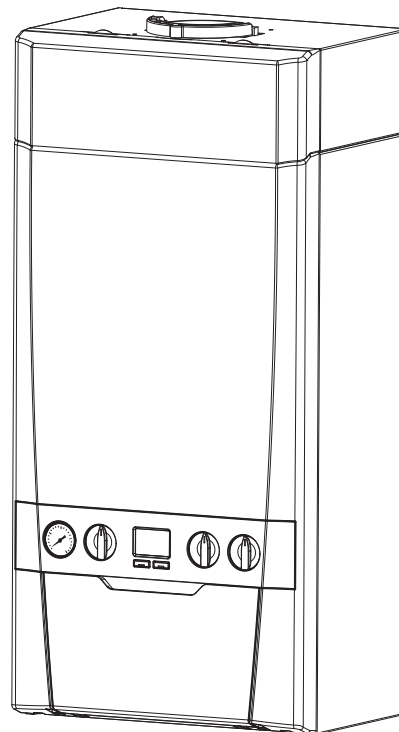

For GB, to comply with Building Regulations Part L1 (Part 6 in Scotland) the boiler should be fitted in accordance with the manufacturer's instructions. Self-certification that the boiler has been installed to comply with Building Regulations can be demonstrated by completing and signing the Benchmark Commissioning Checklist.

Before installing this boiler, read the Code of Practice sheet at the rear of this book.

**BENCHMARK COMMISSIONING CHECKLIST DETAILS**

Boiler	Page	Page	
Make and model.....	9	Burner operating pressure .....	n/a
Appliance serial no. on data badge .....	Front Cover	Central heating flow temp. ....	measure and record
SEDBUK No. %.....	8	Central heating return temp. ....	measure and record
<b>Controls</b>		<b>For combination boilers only</b>	
Time and temperature control to heating .....	33	Scale reducer .....	16
Time and temperature control to hot water .....	34	<i>Hot water mode</i>	
Heating zone valves .....	n/a	Heat input.....	to be calculated
TRV's.....	13	Max. operating burner pressure .....	n/a
Auto bypass .....	13	Max. operating water pressure.....	measure & record
Boiler interlock.....	13	Cold water inlet temp .....	measure & record
<b>For .....</b>	<b>all boilers</b>	Hot water outlet temp.....	measure & record
Flushing to BS.7593.....	16	Water flow rate at max. setting.....	measure & record
Inhibitor .....	16	<b>For condensing boilers only</b>	
<i>Central heating mode</i>		Condensate drain.....	28
Heat input.....	to be calculated	<b>For all boilers:</b>	<i>complete, sign &amp; hand over to customer</i>

For assistance see Technical Helpline on the back page

**NOTE TO THE INSTALLER: COMPLETE THE BENCHMARK COMMISSIONING CHECKLIST AND LEAVE THESE INSTRUCTIONS WITH APPLIANCE**



## 1.1 INTRODUCTION

The **Logic Code Combi ESP1** range of boilers are wall mounted, full sequence, automatic spark ignition, low water content, fanned flue, high efficiency, condensing, combination gas boilers.

The boiler incorporates an additional recuperator to preheat the DHW cold supply prior to being fully heated in the normal plate heat exchanger.

**Note.** *Due to the high efficiency of the boiler a plume of water vapour will form at the terminal during operation.*

Central heating (CH) output is fully modulating with a range of:

26kW 4.8 to 24.2kW

33kW 6.1 to 24.2kW

38kW 7.1 to 24.2kW

Instantaneous domestic hot water (DHW) output is also fully modulating with a maximum of :

26kW 26.1kW

33kW 32.7kW

38kW 38.2kW

The boiler is supplied fully assembled with DHW plate heat exchanger, diverter valve, circulating pump, pressure gauge, safety valve and CH expansion vessel. The boiler also includes a passive flue gas heat recovery device (PFGHRD).

The appliance is listed under SAP to allow PFGHRD benefits to be claimed.

Variable CH and DHW temperature controls are fitted on the user control.

The boiler includes as standard:

- Automatic bypass
- Boiler frost protection
- Daily pump and diverter valve exercise.

The boiler casing is of white painted mild steel with a white polymer front panel.

The boiler temperature controls are visible located in the control panel on the front of the boiler.

The heat exchanger is manufactured from cast aluminium.

The boiler is suitable for connection to fully pumped, sealed heating systems ONLY. Adequate arrangements for completely draining the system by provision of drain cocks MUST be provided in the installation pipework.

Pipework from the boiler is routed downwards.

### Data Plate

The boiler model and serial number can be located on the boiler front panel and on the bottom of the boiler casing as shown in Section 1.17 Water & Gas Connection Diagram.

## 1.2 OPERATION

With no demand for CH, the boiler fires only when DHW is drawn off.

When there is a demand for CH, the heating system is supplied at the selected temperature of between 30°C and 80°C, until DHW is drawn off. The full output from the boiler is then directed via the diverter valve to the plate heat exchanger to supply a nominal DHW draw-off of

26kW 10.7 l/min at 35 °C temperature rise.

33kW 13.4 l/min at 35 °C temperature rise.

38kW 15.7 l/min at 35 °C temperature rise.

The DHW draw off rate specified above is the nominal that the boiler flow regulator will give. Due to system variations and seasonal temperature fluctuations DHW flow rates/temperature rise will vary, requiring adjustment at the draw off tap.

At a low DHW draw-off rate the maximum temperature may exceed 65°C.

The boiler features a comprehensive diagnostic system which gives detailed information on the boiler status when operating, and performance of key components to aid commissioning and fault finding.

## 1.3 SAFE HANDLING

This boiler may require 2 or more operatives to move it to its installation site, remove it from its packaging base and during movement into its installation location. Manoeuvring the boiler may include the use of a sack truck and involve lifting, pushing and pulling.

Caution should be exercised during these operations.

Operatives should be knowledgeable in handling techniques when performing these tasks and the following precautions should be considered:

- Grip the boiler at the base.
- Be physically capable.
- Use personal protective equipment as appropriate, e.g. gloves, safety footwear.

During all manoeuvres and handling actions, every attempt should be made to ensure the following unless unavoidable and/or the weight is light.

- Keep back straight.
- Avoid twisting at the waist.
- Avoid upper body/top heavy bending.
- Always grip with the palm of the hand.
- Use designated hand holds.
- Keep load as close to the body as possible.
- Always use assistance if required.

## 1.4 OPTIONAL EXTRA KITS

Please visit [idealheating.com](http://idealheating.com) to access the Flue and Accessories Guide for this boiler.

## 1.5 SAFETY

### Current Gas Safety (installation and use) regulations or rules in force:

The appliance is suitable only for installation in GB and IE and should be installed in accordance with the rules in force.

In GB, the installation must be carried out by a Gas Safe Registered Engineer. It must be carried out in accordance with the relevant requirements of the:

- Gas Safety (Installation and Use) Regulations
- The appropriate Building Regulations: either The Building Regulations, The Building Regulations (Scotland), Building Regulations (Northern Ireland).
- The Water Fittings Regulations or Water byelaws in Scotland.
- The Current IET Wiring Regulations.

Where no specific instructions are given, reference should be made to the relevant British Standard Code of Practice.

In IE, the installation must be carried out by a Registered Gas Installer (RGI) and installed in accordance with the current edition of I.S.813 "Domestic Gas Installations", the current Building Regulations and reference should be made to the current ETCl rules for electrical installation.

Detailed recommendations are contained in the following British Standard Codes of Practice:

- BS. 5440:1** Flues (for gas appliances of rated input not exceeding 70 kW).
- BS. 5440:2** Ventilation (for gas appliances of rated input not exceeding 70 kW).
- BSEN. 12828:2003** Heating Systems in buildings: Design for water based heating systems.
- BSEN 12831:2003** Heating Systems in buildings: Method for calculation of the design heat load.
- BSEN 14336:2004** Heating Systems in buildings: Installation and commissioning of water based heating systems.
- BS. 5546** Installation of gas hot water supplies for domestic purposes (2nd Family Gases)
- BS. 6798** Installation of gas fired hot water boilers of rated input not exceeding 70 kW.
- BS. 6891** Low pressure installation pipes.

### Health & Safety Document No. 635.

### The Electricity at Work Regulations, 1989.

The manufacturer's notes must NOT be taken, in any way, as overriding statutory obligations.

**IMPORTANT.** These appliances are CE certificated for safety and performance. It is, therefore, important that no external control devices, e.g. flue dampers, economisers etc., are directly connected to these appliances unless covered by these Installation and Servicing Instructions or as otherwise recommended by **Ideal Heating** in writing. If in doubt please enquire.

Any direct connection of a control device not approved by **Ideal Heating** could invalidate the certification and the normal appliance warranty. It could also infringe the Gas Safety Regulations and the above regulations.

## 1.6 SAFE HANDLING OF SUBSTANCES

No asbestos, mercury or CFCs are included in any part of the boiler or its manufacture.

## 1.7 LOCATION OF BOILER

The boiler must be installed on a flat and vertical internal wall, capable of adequately supporting the weight of the boiler and any ancillary equipment.

The boiler may be fitted on a combustible wall and insulation between the wall and the boiler is not necessary, unless required by the local authority.

For electrical safety reasons there must be no access available from the back of the boiler.

### **The boiler must not be fitted outside.**

#### Timber Framed Buildings

If the boiler is to be fitted in a timber framed building it should be fitted in accordance with the Institute of Gas Engineering document IGE/UP/7:2006 Edition 2.

#### Bathroom Installations

This appliance is rated **IP20**.

The boiler may be installed in any room or internal space, although particular attention is drawn to the requirements of the current IET (BS.7671) Wiring Regulations and the electrical provisions of the building regulations applicable in Scotland, with respect to the installation of the boiler in a room or internal space containing a bath or shower. For IE reference should be made to the current ETCl rules for electrical installations and I.S. 813:2002.

If the appliance is to be installed in a room containing a bath or shower then, providing water jets are not going to be used for cleaning purposes (as in communal baths/showers), the appliance must be installed beyond Zone 2, as detailed in BS.7671.

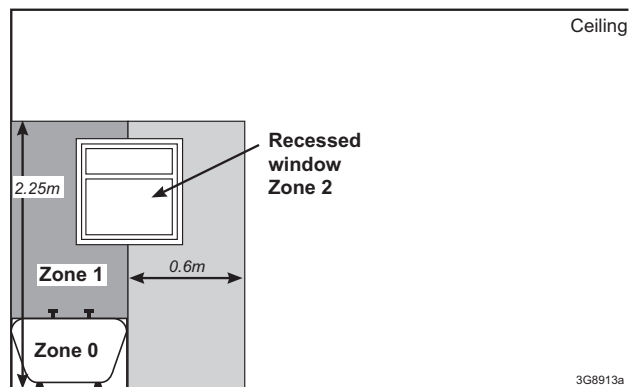

#### Compartment Installations

A compartment used to enclose the boiler should be designed and constructed specially for this purpose.

An existing cupboard or compartment may be used, provided that it is modified for the purpose.

Braces for compartments must be easily removable for service access.

In both cases, details of essential features of cupboard / compartment design, including airing cupboard installation, are to conform to the following:

- BS 6798 (No cupboard ventilation is required - see 'Air Supply' for details).
- The position selected for installation MUST allow adequate space for servicing in front of the boiler.
- For the minimum clearances required for safety and subsequent service, see the wall mounting template and Section 1.17. In addition, sufficient space may be required to allow lifting access to the wall mounting plate.

## 1.8 CARBON MONOXIDE ALARMS

When installing a new boiler, Installers should make sure that a suitable carbon monoxide alarm is installed near to the boiler.

**IMPORTANT:** Carbon monoxide alarms must be installed in any room that has a fixed combustion appliance.

UK Building Regulations state that a carbon monoxide alarm should be installed in the room where:

- a new or replacement fixed combustion appliance (excluding an appliance used solely for cooking) is installed in the dwelling, or
- a new or replacement fixed combustion appliance is installed in a connected space such as an integral garage.

Users and Installers should comply with the Smoke and Carbon Monoxide Alarm (Amendment) Regulations 2022 and BS EN 50291-1:2010, and all applicable local building authority regulations.

Carbon monoxide detectors should use a battery designed to operate for the working life of the detector. Carbon monoxide detectors that are connected to the main electrical supply and comply with BS EN 50291-1:2010 (Type A) may be used, as long as a sensor failure warning device is installed. All detectors should include a warning device to alert the Users when the working life of the detector is scheduled to end.

## 1.9 GAS SUPPLY

The local gas supplier should be consulted, at the installation planning stage, in order to establish the availability of an adequate supply of gas. An existing service pipe must NOT be used without prior consultation with the local gas supplier.

The boiler MUST be installed on a gas supply with a governed meter only.

A gas meter can only be connected by the local gas supplier or by a Gas Safe Registered Engineer. In IE by a Registered Gas Installer (RGII).

An existing meter should be checked, preferably by the gas supplier, to ensure that the meter is adequate to deal with the rate of gas supply required.

It is the responsibility of the Gas Installer to size the gas installation pipework in accordance with BS6891:2005. Whilst the principle of the 1:1 gas valve ensures the Logic range is able to deliver its full output at inlet pressures as low as 14mb, other gas appliances in the property may not be as tolerant. When operating pressures are found to be below the minimum meter outlet of 19mb these should be checked to ensure this is adequate for correct and safe operation.

Allowing for the acceptable pressure loss of 1mb across the installation pipework, it can be assumed that a minimum permitted operating pressure of 18mb will be delivered to the inlet of the appliance. (Reference BS 6400-1 Clause 6.2 Pressure Absorption).

The external gas cock could further reduce the operating pressure when measured at its test point. The pressure drop is relative to the heat input to the boiler (kW), refer to graph below.

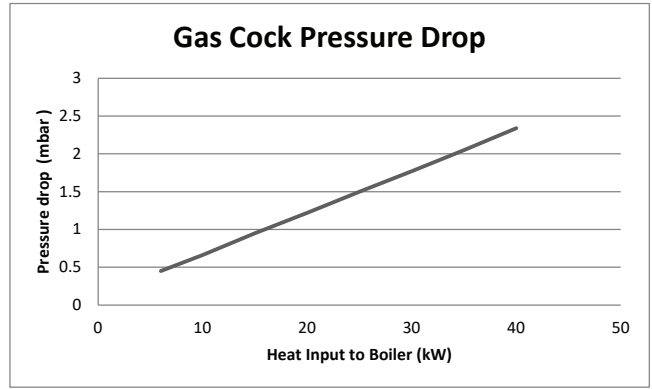

### IMPORTANT.

Ensure all gas valve connections are gas tight with a gas soundness check up to the gas control valve.

Installation pipes must be fitted in accordance with BS.6891. In IE refer to IS.813:2002.

The complete installation MUST be tested for gas tightness and purged as described in the above code.

## 1.10 FLUE INSTALLATION

Plumbing will occur at the terminal so terminal positions where this could cause a nuisance should be avoided.

The flue must be installed in accordance with the recommendations of BS. 5440-1: 2008.

In IE refer to I.S. 813:2002.

The following notes are intended for general guidance:

**Table 4 - Balanced Flue Terminal Position**

Flue Terminal Positions	Min. Spacing*
1. Directly below, above or alongside an opening window, air vent or other ventilation opening.	300mm
2. Below guttering, drain pipes or soil pipes. <i>BS5440-1 2008</i>	25mm* 75mm
3. Below eaves. <i>BS5440-1 2008</i>	25mm* 200mm
4. Below balconies or a car port roof. <i>BS5440-1 2008</i>	25mm* 200mm
5. From vertical drain pipes or soil pipes. <i>BS5440-1 2008</i>	25mm* 150mm
6. From an internal or external corner or to a boundary alongside the terminal. <i>BS5440-1 2008</i>	25mm* 300mm
7. Above adjacent ground, roof or balcony level.	300mm
8. From a surface or a boundary facing the terminal.	600mm
9. From a terminal facing a terminal.	1,200mm
10. From an opening in a car port (e.g. door or window) into dwelling.	1,200mm
11. Vertically from a terminal on the same wall.	1,500mm
12. Horizontally from a terminal on the wall.	300mm
<b>Vertical Terminals</b>	
13. Above the roof pitch with roof slope of all angles. Above flat roof.	300mm 300mm
14. From a single wall face. From corner walls.	300mm 300mm
15. Below velux window	2000mm
16. Above or side of velux window	600mm

\* Only one reduction down to 25mm is allowable per installation otherwise BS5440-1 2008 dimensions must be followed.

1. The boiler MUST be installed so that the terminal is exposed to external air.
2. It is important that the position of the terminal allows the free passage of air across it at all times.

3. Minimum acceptable spacing from the terminal to obstructions and ventilation openings are specified in Table 4.
4. Where the lowest part of the terminal is fitted less than 2m above a balcony, above ground or above a flat roof to which people have access then the terminal **MUST** be protected by a purpose designed guard.

Terminal guards are available from boiler suppliers. (Ask for TFC flue guard model no. K6 - round, plastic coated). In case of difficulty contact:

TFC Group. Tel. + 44 (0) 01732 351 680  
Tower House, Vale Rise Fax. + 44 (0) 01732 354 445  
Tonbridge. Kent TN9 1TB www.tfc-group.co.uk

Ensure that the guard is fitted centrally.

5. The flue assembly shall be so placed or shielded as to prevent ignition or damage to any part of any building.
6. The air inlet/products outlet duct and the terminal of the boiler **MUST NOT** be closer than 25mm to combustible material. Detailed recommendations on the protection of combustible material are given in BS. 5440-1:2008.

**IMPORTANT.** It is essential to ensure, in practice, that products of combustion discharging from the terminal cannot re-enter the building or buildings through any openings into the building such as ventilators, windows, doors, or other sources of natural air infiltration, such as forced ventilation openings etc.

If products of combustion re-entry is identified or suspected this should be immediately investigated and corrected following the guidance provided in the current Gas Industry Unsafe Situation Procedure.

### 1.11 TERMINAL

The terminal assembly can be adapted to accommodate various wall thicknesses. Refer to Section 2.8.

### 1.12 AIR SUPPLY

It is **NOT** necessary to have a purpose-provided air vent in the room or internal space in which the boiler is installed. Neither is it necessary to ventilate a cupboard or compartment in which the boiler is installed, due to the low surface temperatures of the boiler casing during operation; therefore the requirements of BS 6798, Clause 12, and BS 5440:2 may be disregarded.

### 1.13 WATER CIRCULATION SYSTEM

#### **IMPORTANT.**

A minimum length of 1 metre of copper pipe **MUST** be fitted to both flow and return connections from the boiler before connection to any plastic piping.

The central heating system should be in accordance with BS.6798 and, in addition, for smallbore and microbore systems, BS.5449.

**WATER TREATMENT - see Section 1.20.**

### 1.14 BOILER CONTROL INTERLOCKS

Central heating systems controls should be installed to ensure the boiler is switched off when there is no demand for heating, in compliance with Building Regulations.

Heating systems utilising full thermostatic radiator valve control of temperature in individual rooms should also be fitted with a room thermostat controlling the temperature in a space served by radiators not fitted with such a valve.

When thermostatic radiator valves are used, the space heating temperature control over a living / dining area or hallway having a heating requirement of at least 10% of the minimum boiler heat output should be achieved using a room thermostat, whilst other rooms are individually controlled by thermostatic radiator valves. However, if the system employs thermostatic radiator valves on all radiators, or two port valves, then a bypass circuit must be fitted with an automatic bypass valve to ensure a flow of water should all valves be in the closed position.

### 1.15 ELECTRICAL SUPPLY

#### **WARNING.**

This appliance must be earthed.

Wiring external to the appliance **MUST** be in accordance with the current IET (BS.7671) Wiring Regulations and any local regulations which apply. For IE reference should be made to the current ETCI rules for electrical installations.

The mains supply to the boiler and system wiring centre shall be through one common fused double pole isolator and for new heating systems, and where practical replacement installations, the isolator shall be situated adjacent to the appliance.

### 1.16 CONDENSATE DRAIN (Refer to Section 2.14)

A condensate drain is provided on the boiler. This drain must be connected to a drainage point on site. All pipework and fittings in the condensate drainage system **MUST** be made of plastic - *no other materials may be used.*

#### **IMPORTANT.**

Any external runs must be in accordance with BS 6798.

The drain outlet on the boiler is sized for standard 21.5mm overflow pipe. It is a universal fitting to allow use of different brands of pipework.

# SECTION 1 - GENERAL

## 1.17 BOILER DIMENSIONS, SERVICES & CLEARANCES

*all dimensions in mm*

The boiler connections are made on the boiler connection tails. Refer to Section 2.15.

**The following minimum clearances must be maintained for operation and servicing.**

Additional space will be required for installation, depending upon site conditions.

### Side and Rear Flue

- a. Provided that the flue hole is cut accurately, e.g. with a core drill, the flue can be installed from inside the building where wall thicknesses do not exceed 600mm. Where the space into which the boiler is going to be installed is less than the length of flue required the flue must be fitted from the outside.

### Rear Flue Only

Minimum top clearance required is 145mm.

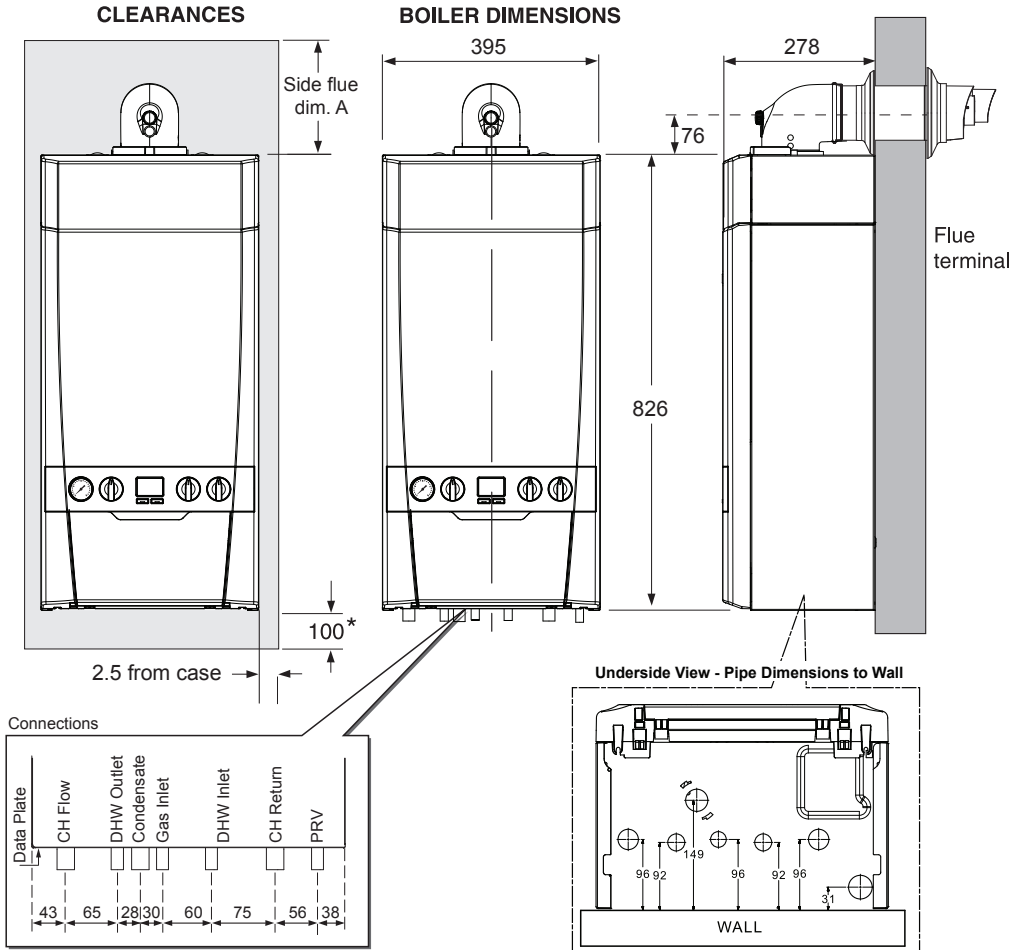

### B = Top Clearance

Top Clearance is measured from the top of the turret to the top of the hole where the flue terminates.

### L = Effective flue length.

The effective length of the flue is measured from the edge of the turret to the flue terminal lip.

Flue systems that require extension kits must be installed with a 1.5° decline from the flue terminal back to the boiler. A 1.5° decline can be achieved by designing the flue with a 26 mm rise per meter length of flue.

\* Ensure the flue terminal is horizontal when passing through the wall. Any flue extensions should be fitted with a 1.5° decline.

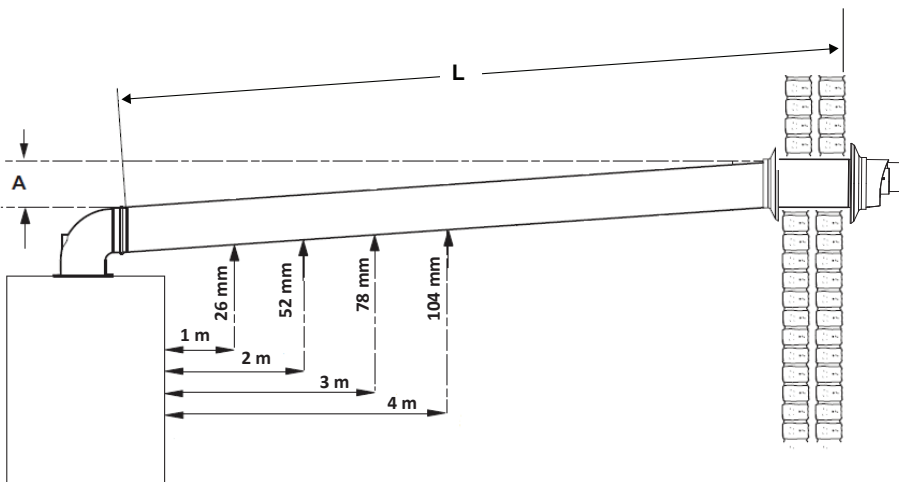

# SECTION 1 - GENERAL

## 1.18 SYSTEM REQUIREMENTS - Central Heating

### Notes

- a. The method of filling, refilling, topping up or flushing sealed primary hot water circuits from the mains via a temporary hose connection is only allowed if acceptable to the local water authority.
- b. Antifreeze fluid, corrosion and scale inhibitor fluids suitable for use with boilers having aluminium heat exchangers may be used in the central heating system.

### General

1. The installation must comply with all relevant national and local regulations.
2. The installation should be designed to work with flow temperatures of up to 86 °C.
3. All components of the system must be suitable for a working pressure of 3 bar and a maximum design temperature of 110 °C. Extra care should be taken in making all connections so that the risk of leakage is minimised.

The following components are incorporated within the appliance:

- a. Circulating pump.
  - b. Safety valve, with a non-adjustable preset lift pressure of 3 bar.
  - c. Pressure gauge, covering a range of 0 to 4 bar.
  - d. An 8-litre expansion vessel, with an initial charge pressure of 0.75 bar.
4. **'Make-up' Water.** Provision must be made for replacing water loss from the system, either :

- a. From a manually filled 'make-up' vessel with a readily visible water level. The vessel should be mounted at least 150mm above the highest point of the system and be connected through a non-return valve to the system, fitted at least 150mm below the 'make-up' vessel on the return side of the radiators. **or**
- b. Where access to a 'make-up' vessel would be difficult, by pre-pressurisation of the system.

The maximum cold water capacity of the system should not exceed 143 litres, if not pressurized. However, if the system is to be pressurized, the efficiency of the expansion vessel will be reduced and a larger vessel (or smaller system volume) may be necessary. If the capacity of the vessel is not considered sufficient for this, or for any other reason, an additional vessel **MUST** be installed on the return to the boiler.

Guidance on vessel sizing is given in the above table.

<b>Safety valve setting</b>	bar	3.0	
<b>Vessel charge pressure</b>	bar	0.5 to 0.75	
<b>System pre-charge pressure</b>	bar	None	1.0
<b>System volume (litres)</b>		<b>Expansion vessel volume (litres)</b>	
25		1.6	1.8
50		3.1	3.7
75		4.7	5.5
100		6.3	7.4
125		7.8	9.2
150		9.4	11.0
175		10.9	12.9
190		11.9	14.0
200		12.5	14.7
250		15.6	18.4
300		18.8	22.1
<b>For other system volumes multiply by the factor across</b>		0.063	0.074

### Water Flow Rate and Pressure Loss

Max CH Output	kW	24.2
Water flow rate	l/min	17.3
Temperature Differential	°C	20
Head available for system	m.w.g.	3.8

### 5. Filling

The system may be filled by the following method:

Where the mains pressure is excessive a pressure reducing valve must be used to facilitate filling.

- a. Thoroughly flush out the whole system with cold water.
- b. Fill and vent the system until the pressure gauge registers 1bar and examine for leaks. Refer to Section 2.15 for filling detail.
- c. Check the operation of the safety valve by raising the water pressure until the valve lifts. This should occur within 0.3bar of the preset lift pressure.
- d. Release water from the system until the minimum system design pressure is reached; 1.0 bar if the system is to be pre-pressurised.

*continued . . . . .*

## SYSTEM REQUIREMENTS - CONT'D

### Domestic Hot Water

1. The DHW service must be in accordance with BS5546 & BS6700.
2. Refer to Table 1 for minimum and maximum working pressures. In areas of low mains water pressures the domestic hot water regulator may be removed from the DHW flow turbine cartridge. Refer to Section 3.25. The boiler will require the flow rate to be set to obtain a temperature rise of 35°C at the tap furthest from the boiler.
3. The boilers are suitable for connection to most types of washing machine and dishwasher appliances.
4. If the shower/mixer valve does not incorporate non-return valves the following must be followed:
  - a. The cold inlet to the boiler is fitted with an approved anti-vacuum or syphon non-return valve.
  - b. Hot and cold water supplies to the shower are of equal pressure.

### 5. Hard Water Areas

Where the water hardness exceeds 200mg/litre, it is recommended that a proprietary scale reducing device is fitted into the boiler cold supply within the requirements of the local water company.

**IMPORTANT.** Provision must be made to accommodate the expansion of DHW contained within the appliance. If the DHW inlet contains a back flow prevention device or non-return valve, e.g. a water meter, then a mini expansion vessel should be fitted between the device and the boiler in the cold inlet pipe.

**Note.** DHW Expansion Vessel kit available from Ideal. Please visit [idealheating.com](http://idealheating.com) to access the Flue and Accessories Guide.

## 1.19 SYSTEM BALANCING

The boiler does not normally need a bypass but at least some radiators on the heating circuit, of load of at least 10% of the minimum boiler output, must be provided with twin lockshield valves so that this minimum heating load is always available. See note regarding thermostatic radiator valves on section 1.13.

**Note.** *Systems incorporating zone valves which could completely cut off the flow through the system must also include a bypass.*

### BALANCING

1. Set the programmer to ON.

Close the manual or thermostatic valves on all radiators, leaving the twin lockshield valves (on the radiators referred to above) in the OPEN position.

Turn up the room thermostat and adjust the lockshield valve to give an uninterrupted flow through the radiator.

These valves should now be left as set.

2. Open all manual or thermostatic radiator valves and adjust the lockshield valves on the remaining radiators, to give around 20°C temperature drop at each radiator.
3. Adjust the room thermostat and programmer to NORMAL settings.

## 1.20 WATER TREATMENT

### CENTRAL HEATING

The Logic Code Combi ESP1 range of boilers have an ALUMINIUM alloy heat exchanger.

#### IMPORTANT.

**The application of any other treatment to this product may render the guarantee of Ideal Heating Invalid.**

**Ideal Heating** recommend Water Treatment in accordance with the Benchmark Guidance Notes on Water Treatment in Central Heating Systems.

If water treatment is used **Ideal Heating** recommend only the use of SCALEMASTER SM-1 PRO, FERNOX, MBI, ADEY MC1 or SENTINEL X100 inhibitors and associated water treatment products, which must be used in accordance with the manufacturers' instructions.

### DOMESTIC HOT WATER

In hard water areas where mains water can exceed 200ppm Total Hardness (as defined by BS 7593:2006 Table 2) a scale reducing device should be fitted into the boiler cold supply within the requirements of the local water company. The use of artificially softened water, however, is not permitted.

**Ideal Heating** recommend the use of Fernox Quantomat, Sentinel Combiguard, Calmag CalPhos I scale reducing devices or Scalemaster In-line Scale Inhibitor branded Ideal, which must be used in accordance with the manufacturers' instructions.

#### Notes.

1. *It is most important that the correct concentration of the water treatment products is maintained in accordance with the manufacturers' instructions.*
2. *If the boiler is installed in an existing system any unsuitable additives MUST be removed by thorough cleansing. BS 7593:2006 details the steps necessary to clean a domestic heating system.*
3. *In hard water areas, treatment to prevent lime scale may be necessary - however the use of artificially softened water is NOT permitted.*
4. *Under no circumstances should the boiler be fired before the system has been thoroughly flushed.*

For further information contact:

#### Fernox Cookson Electronics

Forsyth Road, Sheerwater, Woking, Surrey GU21 5RZ  
+44 (0) 870 601 5000

#### Sentinel Performance Solutions

The Heath Business & Technical Park  
Runcorn, Cheshire WA7 4QX  
Tel: 0800 389 4670

#### Scalemaster Water Treatment Products

Emerald Way, Stone, Staffordshire ST15 0SR  
Tel: +44 (0) 1785 811636

#### Calmag Ltd.

Unit 3-6, Crown Works, Bradford Road,  
Sandbeds, Keighley, West Yorkshire BD20 5LN  
Tel: +44 (0) 1535 210 320

#### Adey Professional Heating Solutions

Gloucester Road, Cheltenham GL51 8NR  
Tel: +44 (0) 1242 546700



## SECTION 2 - INSTALLATION

### 2.2 UNPACKING

The boiler is supplied fully assembled in Pack A. A telescopic or non-telescopic flue assembly for rear or side flue outlet in Pack B is supplied as a separate order.

Unpack and check the contents.

#### Pack A Contents

- A Boiler
- B Hardware Pack Box
- C Wall Mounting Plate
- D These Installation/Users Instructions
- E Wall Mounting Template
- F Boiler Guarantee & Registration Pack

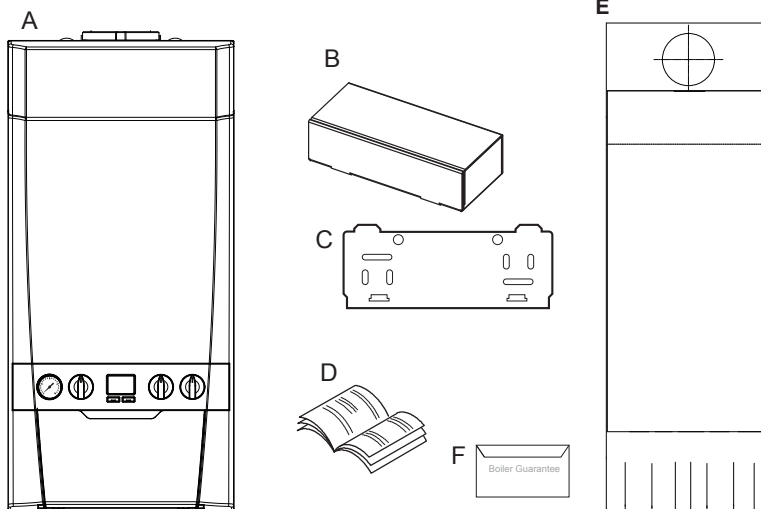

#### HARDWARE PACK CONTENTS

##### Gas Valve Pack

1. Pipe - Gas Inlet
2. Washer - Gas (blue)
3. Gas Cock

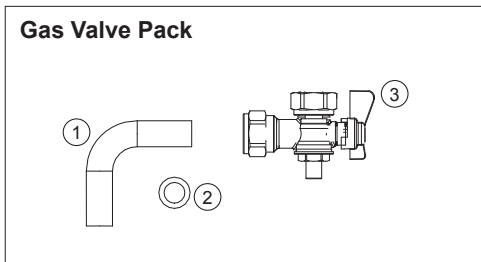

##### Filling Loop Pack

1. 3/8" Top Hat Washer
2. Valve Filling Loop
3. Pipe Filling Loop
4. Washer Fibre 3/8"

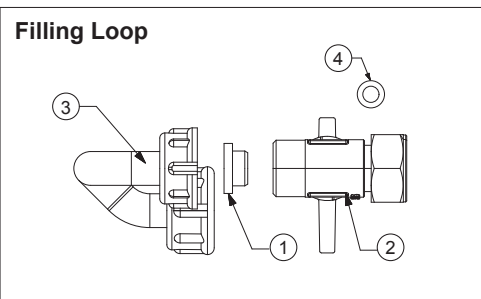

##### Return Valve Pack

1. Pipe CH Return
2. Washer CH
3. Valve Return

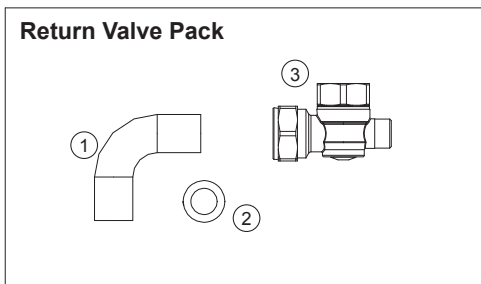

##### DHW Pack

1. 1/2" Top Hat Washer (x2)
2. Cap Female
3. Plug Male and Clip
4. Nut G1/2 16 Brass (Flat)
5. Washer 18.5 x 11 x 11.8 (x2)
6. Pipe DHW Outlet
7. Pipe DHW Inlet
8. Valve DHW Inlet

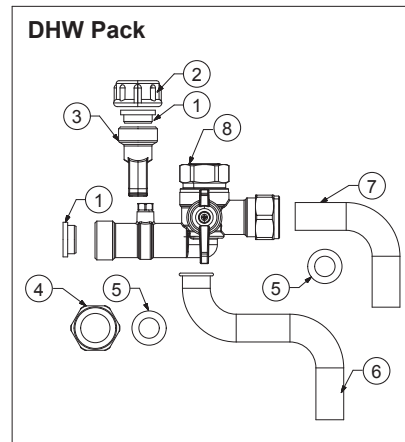

##### Accessory Pack

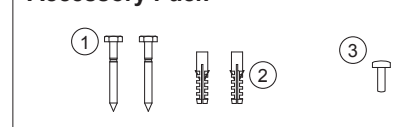

##### Accessory Pack

1. Screw (x2)
2. Wallplug (x2)
3. Turret Clamp Screw (spare)

##### Flow Valve Pack

1. Pipe CH Flow
2. Washer CH
3. Valve Flow

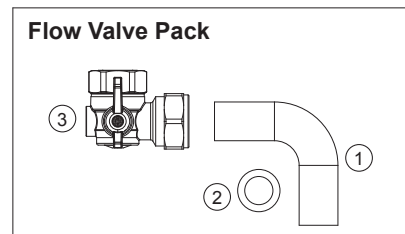

continued . . . . .

**UNPACKING CONT'D**

**Note.** This flue system incorporates a removable flue outlet nose that utilises a push fit location system. This enables the installation of deflector, high level, soffit or balcony outlet flue kits without the removal of the whole 'B' pack terminal. The appliance must not be operated without the desired outlet nose correctly fitted in place.

*Note.* Location dimples must be aligned with terminal mounting frame.

**Pack B Contents Non-Telescopic**

- A Flue terminal
- B Flue turret
- C Rubber terminal wall seal
- D Cutting Aid
- E Wall Seal (white)

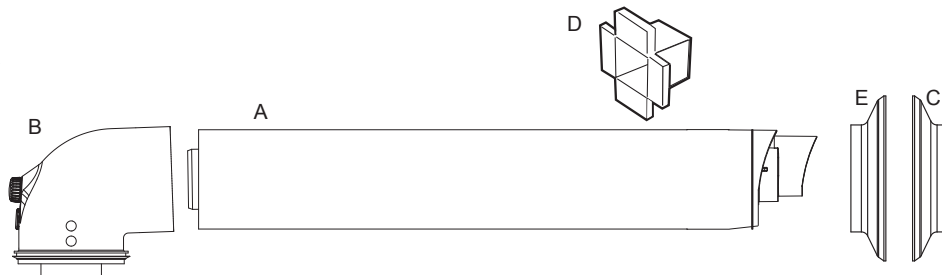

**Pack B Contents Telescopic**

- A Telescopic flue terminal
- B Flue turret
- C Rubber terminal wall seal
- D Screw
- E Sealing Tape
- F Wall Seal (white)

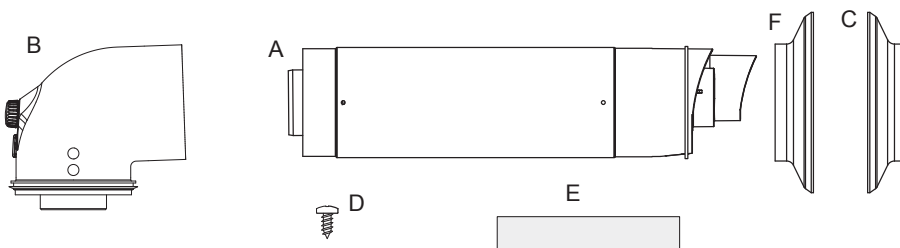

**2.3 POD DOOR & FRONT PANEL REMOVAL**

**POD DOOR**

1. Squeeze the two tabs forward and lift the pod door upwards to remove.

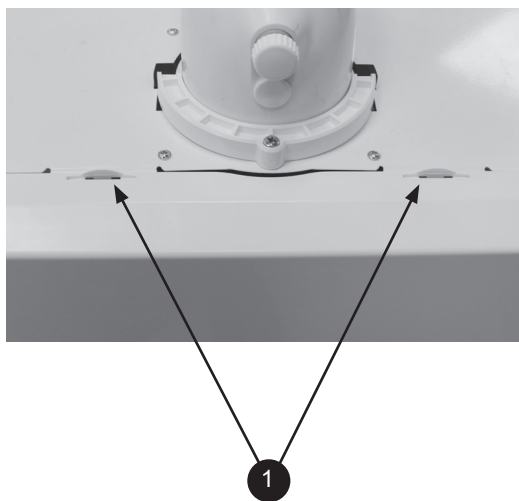

**BOILER FRONT PANEL**

1. Loosen the 2 screws retaining the front panel.
2. Pull the two clips downwards to disengage.
3. Pull the front panel forward and upwards to remove.

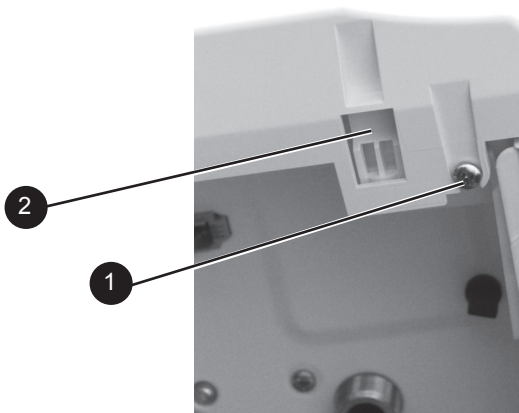

## SECTION 2 - INSTALLATION

### 2.4 WALL MOUNTING TEMPLATE

The wall mounting template is located on the internal protective packaging. The template shows the position of the fixing and rear flue centre holes for a standard installation

*Care MUST be taken to ensure the correct holes are drilled.*

1. Tape template into the required position, ensuring its squareness by hanging a plumbline as shown.
2. If fitting a side flue, extend the flue centreline onto the side by **155mm** on a standard wall fix or **200mm** if using a stand-off bracket.
3. Mark the following on to the wall:
  - a. The selected group of wall mounting screw holes.
  - b. The centre position of the flue duct. Marking both the centre and the circumference of the flue duct.
4. Remove the template plate from the wall.

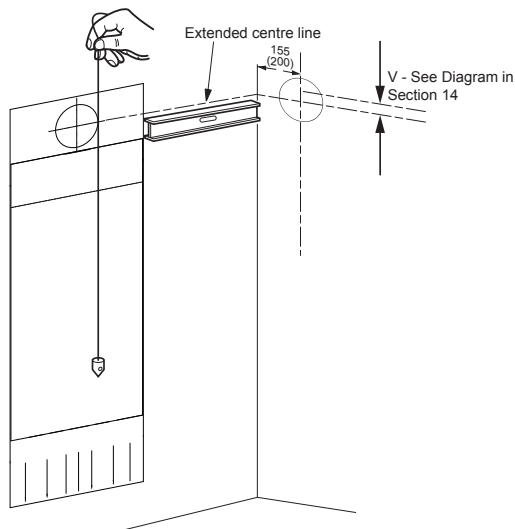

### 2.5 PREPARING THE WALL

#### IMPORTANT.

Ensure that, during the cutting operation, masonry falling outside of the building does not cause damage or personal injury.

1. Cut the flue hole (preferably with a 5" core boring tool), ensuring that the hole is square to the wall. Both wall faces immediately around the cut hole should be flat.
2. Drill 2 mounting holes (marked from template) with a 7.5mm / 8mm masonry drill and insert the plastic plugs, provided, for the wall mounting plate.
3. Locate 2 No.14 x 50mm screws in the wall mounting plate (one at each side, in any of the 3 holes provided at each side) and screw home. Ensure mounting bracket is level.

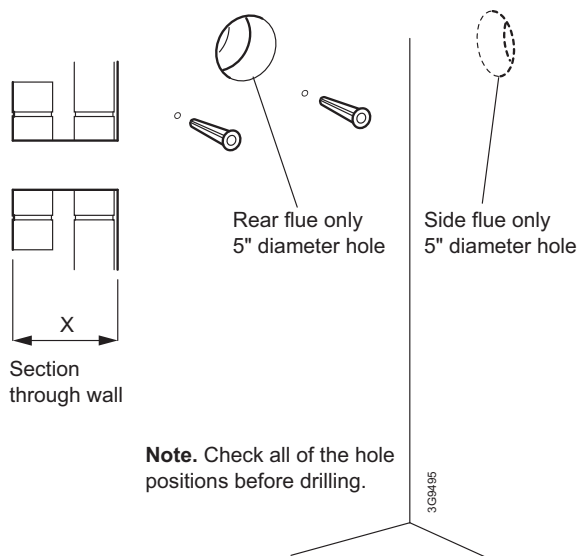

### 2.6 FITTING THE WALL MOUNTING PLATE

Screw the wall mounting plate to the wall using 2 wall plugs (previously fitted) with the 2 screws provided.

Choose one of the 2 sets of slots in left and right bank. Ensuring that at least one of the screws is fitted into a top slot and the mounting bracket is level.

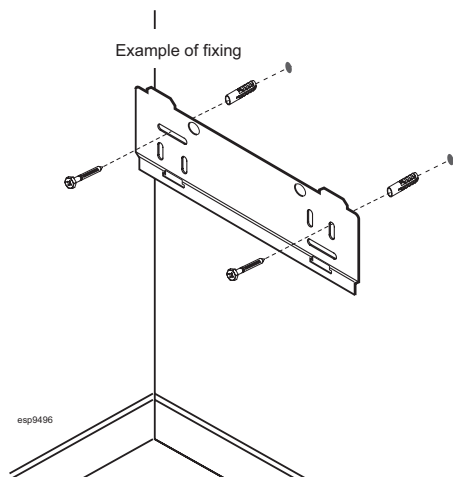

### 2.7 MOUNTING THE BOILER

1. Ensure the plastic plugs are removed from both the CH and DHW connections before mounting the boiler.
 

*Caution: water may discharge from open pipes.*
2. Lift the boiler onto the wall mounting plate (refer to the introduction section for safe handling advice) locating it over the two tabs, which can be viewed through the upper pod.

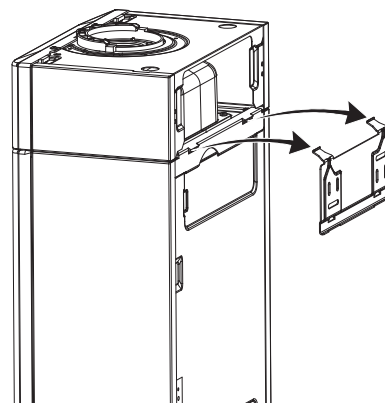

## SECTION 2 - INSTALLATION

### 2.8 DETERMINING THE FLUE LENGTH AND FLUE PACKS REQUIRED

**IMPORTANT.** The boiler must be installed in a vertical position in accordance to the installation instructions.

#### FLUE KITS

**Telescopic Flue 'B' Pack** - contains: Flue turret, telescopic flue incorporating a terminal and rubber wall seals.

**Horizontal Flue Terminal (600mm long) 'B' Pack** - contains: Flue turret, non telescopic single piece flue incorporating a terminal and rubber wall seals.

**Horizontal Flue Terminal (1000mm long) 'B' Pack** - Flue turret, telescopic flue incorporating a terminal, rubber wall seals and instructions.

*Note. If 'B' packs are used on their own (either 1 piece or telescopic), then they MUST fitted horizontally as the flue inside is designed to slope 1.5 degrees.*

**D Pack Flue Extension 100mm DIA 1000mm long**

**D Pack Flue Extension 100mm DIA 500mm long**

**D Pack Flue Extension 100mm Dia 2000mm long**

**Roof Flue Kit with Vertical Connector**

*When extension 'D' Packs are used the flue duct must incline 1.5 degrees away from the appliance, to allow the condensate to drain back to the boiler and out of the condensate drain. It is recommended that a support bracket is fitted on every 1 metre*

*of flue used and the bracket is located as close to the collar as possible. The bracketing must ensure a 1.5 degree fall back to the appliance.*

**Optional Flue Finishing Kit** - Concentric Flue Screw Retaining Kit (Optional Kit of mechanical fixing of flue joints)

Only use water as a lubricant during assembly.

The 'B' pack terminal is classed as part of the maximum flue length.

These flue systems incorporate a removable flue outlet nose that utilises a push fit location system. This enables the installation of deflector, high level or balcony flue kits without the removal of the whole 'B' pack terminal. The appliance must not be operated without the desired outlet nose correctly fitted in place, ensuring the side location dimples are in line with the mounting face allowing the correct sealing of the components.

It is **IMPORTANT** that all attachments are fitted in accordance to the installation instructions provided with them.

The TURRET supplied in the 'B' Pack has an upper combustion sample point with a screw cap seal and a lower air sample point with an air stopper seal. Ensure all caps & seals are in place.

**Additional Termination Kits** are available for use with these 'B' packs.

Flue Deflector Kit	The resistance is the equivalent of 1 metre of flue pipe and therefore must be deducted from any maximum flue length
High Level Flue Outlet Kit	The maximum permissible concentric flue length when using a standard (500mm) kit is 4.5 metres
Balcony Flue Outlet Kit	The maximum permissible concentric flue length when using this kit is dependant on the length of the balcony flue outlet run which combined with the concentric run must not exceed the maximum flue length requirement of the appliance it is to be fitted to
Soffit Kit	This kit enables fitment of an external flue below soffits

**Total Maximum Permissible Horizontal Concentric Flue Length** combining both 'B' Packs and 'D' Packs  
(Measured from centreline of the turret to the outside of the wall terminal)

26 kW Appliances	Total Maximum: 9 metres - minus any flue kit options or bends
32 kW Appliances	Total Maximum: 8 metres - minus any flue kit options or bends
38 kW Appliances	Total Maximum: 6 metres - minus any flue kit options or bends

**Total Maximum Permissible Vertical Flue Length** combining both Roof Terminal and 'D' Packs

26, 32 & 38kW Appliances	Total Maximum: 7.5 Metres - minus any bends
<b>Powered Vertical Flue</b>	
26, 32 & 38kW Appliances	Example: 5 Metres - Concentric Flue and 17m flue pipe only. For additional configurations and details refer to the Powered Vertical Instructions

**90° Elbow Kit 60/100** - (Equivalent flue length resistance = **1M**)

**45° Elbow Kit 60/100** - (Equivalent flue length resistance = **0.6M**)

**Minimum Horizontal Flue Lengths** (Centre line of turret to outside of wall terminal)

Telescopic Flue 'B' Pack = 400mm

Horizontal Flue terminal (600mm long) 'B' Pack = 285mm

#### Wall Thickness

Std Metric Brick 102.5mm wide

'B' Pack Flue Type 60/100	Minimum permissible Wall Thickness			Maximum permissible Wall Thickness		
	Rear Flue	Rear Flue + Std-Off	Side Flue	Rear Flue	Rear Flue + Std-Off	Side Flue
Horizontal Flue Terminal (600mm long) B Pack	126	102.5	102.5	501	456	456
Telescopic Flue B Pack	231	186	186	429	384	384
Horizontal Flue Terminal (1000mm long) B Pack	546	501	501	761	716	716
Horizontal Flue Terminal (1000mm long) B Pack cut 75mm	471	426	426	686	641	641

\* If wall thickness is <126mm and >102.5mm, contact Ideal Heating.

**For Flue lengths between 658 & 708 use a Horizontal Flue Terminal (1000mm long) B Pack, cut 75mm off the end of the terminal section of the telescopic flue only.**

## SECTION 2 - INSTALLATION

### DETERMINING THE FLUE LENGTH AND FLUE PACKS REQUIRED, CONT'D

**FIGURE 1**

Note. Maximum permissible flue length is measured from centre line of appliance flue outlet to outside wall face.

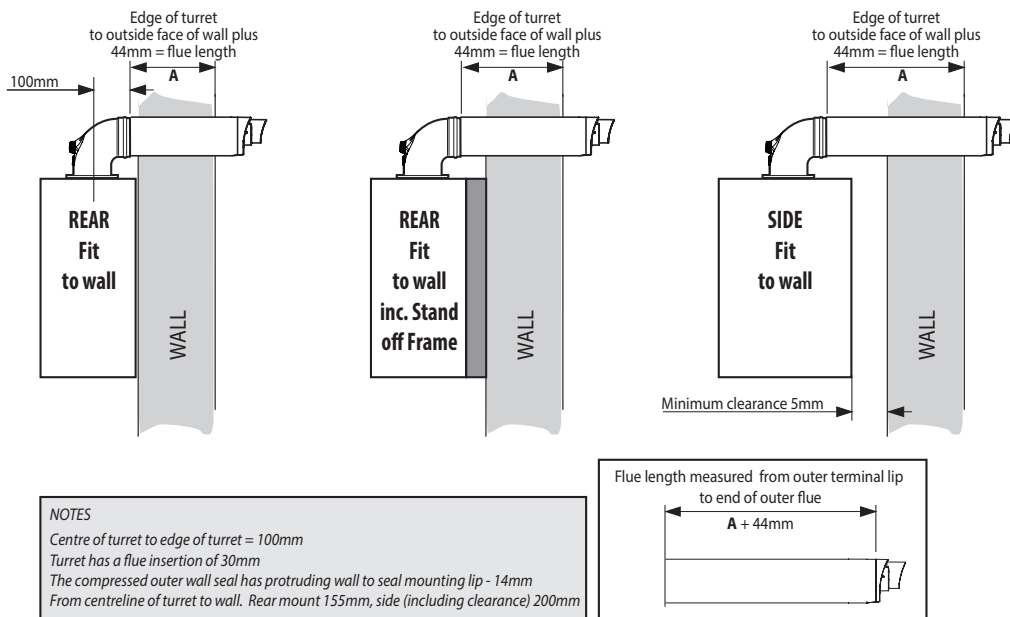

**FIGURE 2**

Shows the flue required when measured from outside edge of turret to the outside face of the wall (to obtain cut length add 44mm)

Minimum & Maximum finished flue lengths obtainable (dimension 'A' +44mm)								
	Horizontal Flue Terminal (600mm long) B Pack		Telescopic Flue B Pack		Horizontal Flue Terminal (1000mm long) B Pack (Telescopic)		Horizontal Flue Terminal (1000mm long) B Pack (Telescopic) Cut 75mm	
	Minimum	Maximum	Minimum	Maximum	Minimum	Maximum	Minimum	Maximum
<b>B Pack (Standard)</b>	181	556	286	484	601	816	526	741
Plus 1 (1m D pack)	1121	1506	1236	1434	1551	1766	1476	1691
Plus 2 (1m D pack)	2071	2456	2186	2384	2501	2716	2426	2641
Plus 3 (1m D pack)	3021	3406	3136	3334	3451	3666	3376	3591
Plus 4 (1m D pack)	3971	4356	4086	4284	4401	4616	4326	4541
Plus 5 (1m D pack)	4921	5306	5036	5234	5351	5566	5276	5491
Plus 6 (1m D pack)	5871	6256	5986	6184	6301	6516	6226	6441
Plus 7 (1m D pack)	6821	7206	6936	7134	7251	7466	7176	7391
Plus 8 (1m D pack)	7771	8186	7886	8084	8201	8416	8126	8341
Plus 9 (1m D pack)	8721	9000	8836	9000	9000	9000	9000	9000

Max output 38 kW

Max output 33 kW

Max output 26 kW

Note; Telescopic flue B Pack or attached "D" pack extensions do not need to be cut between minimum and maximum values shown above (except where specified). Horizontal Flue Terminal (600mm long) B Pack flue will require cutting on values below maximum values shown in the table above.

If using the 2000mm D Pack, the maximum usable length per extension is 1950mm

If using the 500mm D Pack, the maximum usable length per extension is 450mm.

2.9 CUTTING & SETTING THE FLUE LENGTH

TELESCOPIC FLUES

TELESCOPIC FLUE B PACK SHOULD ONLY BE ADJUSTED FOR USE WITHIN ITS SPECIFIED RANGE AND MUST NOT BE CUT.

HORIZONTAL FLUE TERMINAL (1000MM LONG) B PACK (TELESCOPIC) MUST ONLY BE CUT IF REQUIRED FLUE LENGTHS ARE BETWEEN 602 & 652MM. THIS WILL REQUIRE 75MM TO BE CUT OFF THE TERMINAL END OF THE 1000MM TELESCOPIC FLUE.

ALL OTHER LENGTHS OBTAINED USING "D" PACK EXTENSIONS IN FLUE LENGTH TABLE 1, COLUMN "HORIZONTAL FLUE TERMINAL (1000MM LONG) B PACK CUT 75MM" (TELESCOPIC) SHOULD HAVE THE 75MM CUT OFF THE "D" PACK EXTENSION AND NOT TELESCOPIC FLUE.

CUT 75MM OFF HORIZONTAL FLUE TERMINAL 1000MM LONG B PACK (TELESCOPIC)

1. Measure cut flue length (A+44mm). (If required telescopic length is not between 658 and 708 then proceed to "Setting Telescopic Flue B Pack").
2. Remove telescopic end piece from the flue body and set aside.
3. Mark the circumference 75mm from the open end of the outer flue.
4. Cut along the 75mm mark cutting **only the outer flue** ensuring the cut is square.
5. Dress the cut end to make sure all burr is removed and the cut edge is in its original shape.
6. Measure 20mm from the newly cut edge of the outer flue, place a mark at the top of the flue approximately 20mm wide & write stop on the terminal side of the line.
7. Mark the inner tube 10mm longer than the outer tube around its circumference and cut following the mark to ensure it's cut square
8. Remove all burrs and place a chamfer on the outer edge to aid assembly.
9. Re-assemble telescopic section.

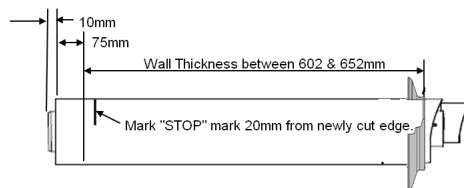

SETTING TELESCOPIC FLUE B PACK

1. Measure the required flue length (A+44mm).
2. Measure from the outer terminal lip to end of outer flue. Pull apart flue until desired length is achieved. ENSURE THE STOP MARK IS NOT VISIBLE, IF IT IS, THE FLUE IS TOO SHORT AND SHOULD NOT BE USED.
3. Check that both flue seams are at the top and the outlet terminal is upper most.
4. Drill a 3.5mm hole through one of the 2 outer side holes in the outer flue section into the inserted outer flue (as shown). Take care not to pierce the inner plastic flue. Fit screw provided.
5. Seal the joint on the outer air duct with the tape provided.
6. Fit internal and external wall seals (see installing flue).

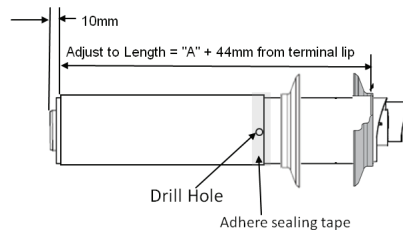

CUTTING HORIZONTAL FLUE TERMINAL (600MM LONG) B PACK

1. Measure the required cut flue length (A+44mm). If inside the dimensions shown in Figure 2 "1 Piece 600mm" proceed.
2. Measure from the outer terminal lip to end of outer flue. Mark the required cut length (A+44) around the circumference of the outer flue and cut following the mark to ensure it's cut square.
3. Dress the cut end to make sure all burrs are removed and the cut edge is in its original shape.
4. Mark the inner tube 10mm longer than the outer tube around its circumference and cut following the mark to ensure its cut square.
5. Remove all burrs and place a light chamfer on the outer edge to aid assembly.

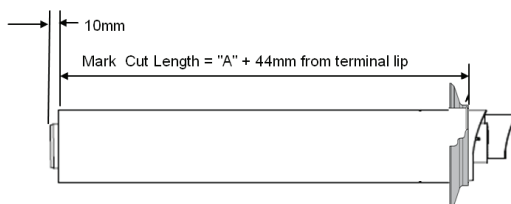

## 2.10 INSTALLING THE FLUE

### FITTING FLUE THROUGH THE WALL

1. Measure wall thickness and add 14mm.
2. Measure from the outer terminal lip towards the end of outer flue, place a small location mark at the dimension acquired at point 1.
3. Add a further 14mm to the dimension, obtain at item 1 (point 1) and place an additional small location mark.
4. Fit external black wall seal ensuring the inside of the outer lip is in contact with the terminal lip you have been measuring from (see fig 1).
5. Fit the internal wall seal approximately 65mm before the outer of the 2 location marks.
6. For an internal fit place flue terminal in the centre of the 5" drilled hole in the wall. Apply pressure and lightly move the flue left to right or up and down. This will cause the outer flange to fold in and allow the flue to pass through the wall.
7. Push through a further 65mm or until the inner flange is pressed against the inner wall. This will allow the outer flange to return to its original shape.
8. Pull back the flue until the first of the 2 location marks is level with the internal face of the wall.

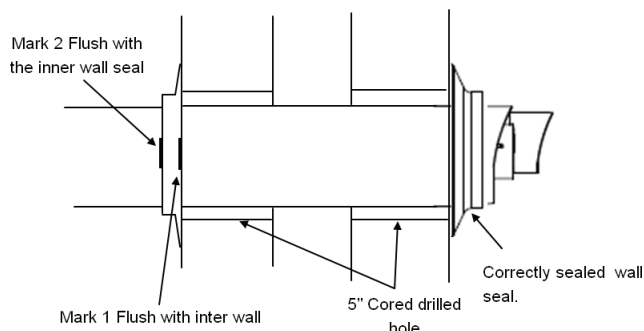
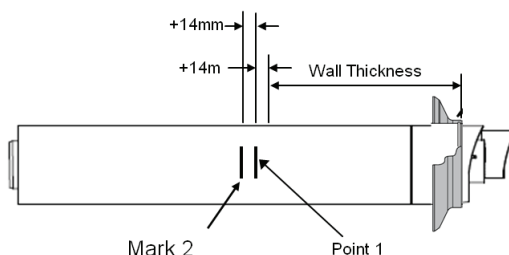

*Note. If the 2 location marks are not visible then the flue is not pulled back far enough to obtain the correct seal. If the 1st location mark has passed the face of the wall the flue has been pulled too far back and the outer wall seal will have been dislodged from its mounting and will need to be refitted.*

9. When 1st mark is in line with the wall, whilst holding the flue firmly, push the white wall sealing flange to the wall until the 2nd of the two marks is just visible. If the last location mark has clearly passed the white inner wall seal then the outer wall seal will have been dislodged from its mounting and will need to be re-fitted.
10. Ensure the seam and the outlet terminal are at the top and fitted as shown.

*Note. If less than 50% of the length of the flue is internal the flue should be fitted from outside.*

**Fig 1**

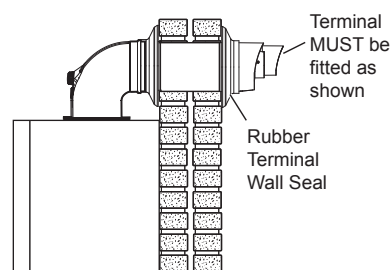
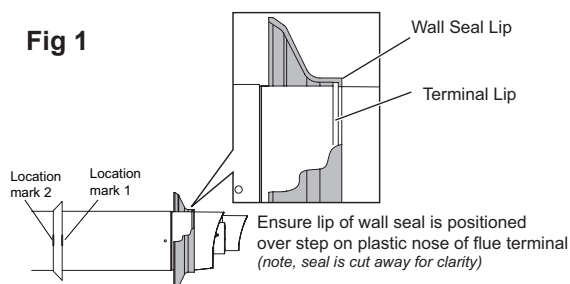

### FITTING THE TURRET - Ensure the condense trap/siphon is filled with water

1. Ensure the rubber seal is fitted correctly on the appliance manifold and that all flue seals are undamaged.
2. Hold the flue firmly and push the turret on until it has travelled 30mm on to the flue pipe and is fully engaged. Make sure the flue has not rotated or moved forward during fitting and the flue seam is upper most.
3. Push the turret into the manifold ensuring the upper plastic lip is flush with the top of the manifold.
4. Fully engage the clamp location section into the manifold location holes. Rotate down on to turret flange.
5. Secure clamp to appliance using securing screw.
6. Ensure all sample points are accessible and all sample plugs and caps are fitted.

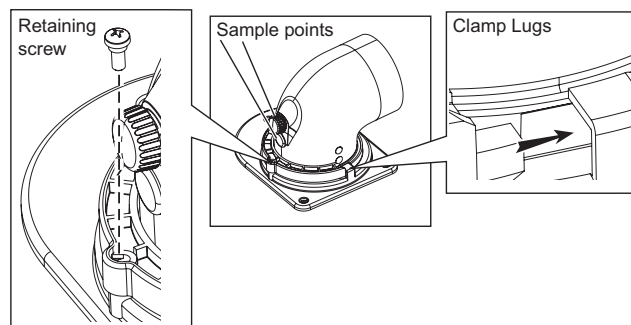
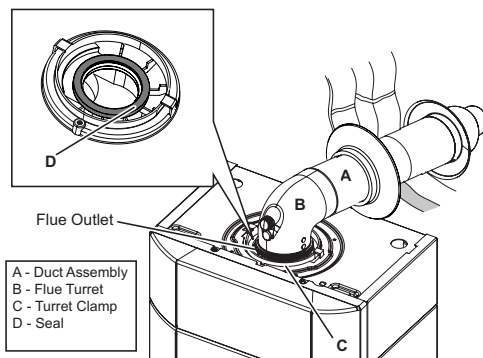

### 2.11 FITTING THE OPTIONAL ROOF FLUE KIT (Flat or Pitched)

**Note.**

A flat or pitched roof flashing plate (not supplied) is required before proceeding with the installation of this kit.

This kit is suitable for both flat and pitched roof terminations, using a concentric flue to run vertically from the top of the boiler and terminating above roof level.

Connection to the top of the boiler is made using the vertical connector.

**WEATHER PROOFING**

Where the flue passes through the roof line an adequate seal must be made.

This is achieved by using either:

- Flat roof weather collar
- or
- Universal weather collar.

**ACCESSORIES**

Flue Duct Extension Kits are available for flue lengths extending beyond 1m. These packs contain 500mm, 1000mm and 2000mm extension ducts and may be cut to the desired length.

If the offset vertical option is used an Elbow Kit is required.

Please visit [idealheating.com](http://idealheating.com) to access the Flue and Accessories Guide for this boiler.

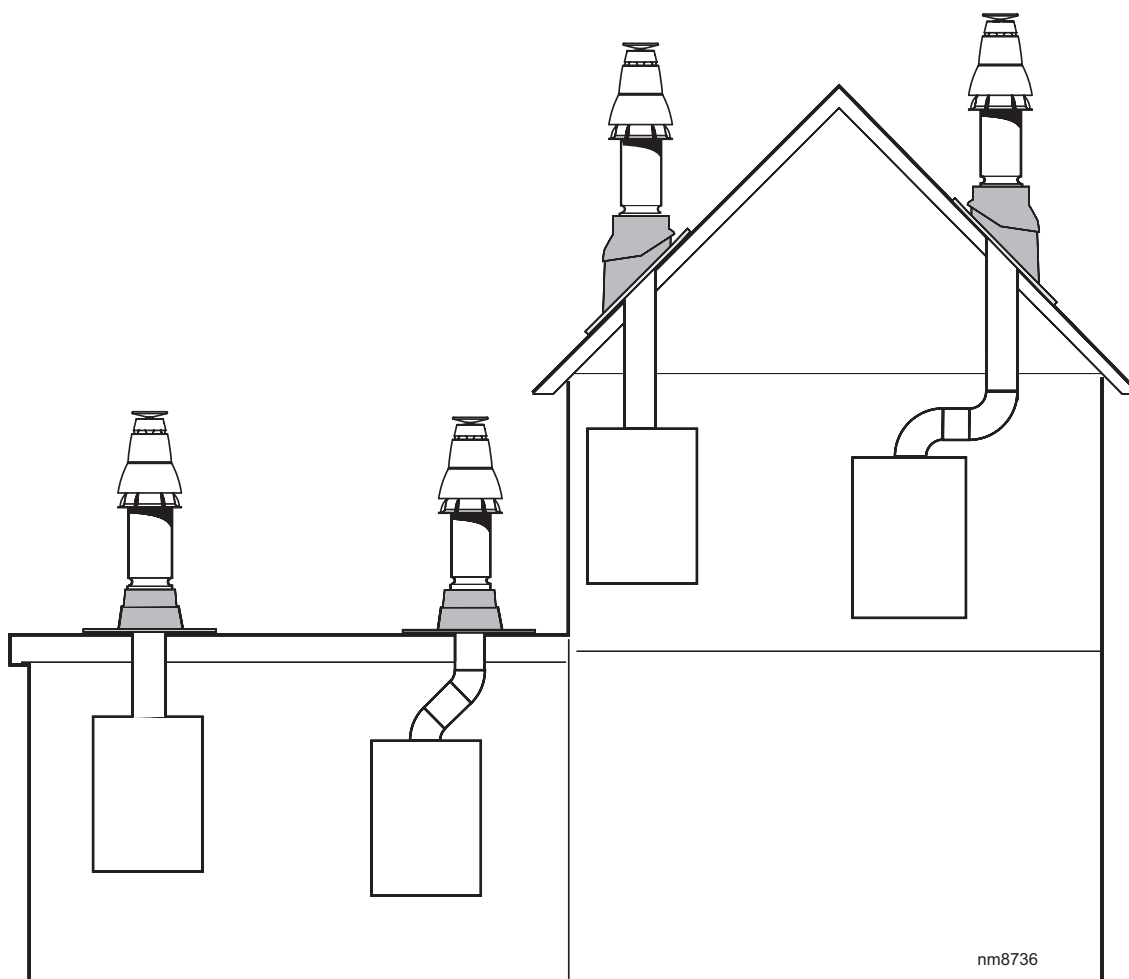

## SECTION 2 - INSTALLATION

### 2.12 FLUE TERMINAL POSITION

The terminal should be positioned so that products of combustion can safely disperse at all times.

Plumbing may occur at the termination so, where possible, terminal positions where this could cause a nuisance should be avoided.

Minimum dimensions are shown below

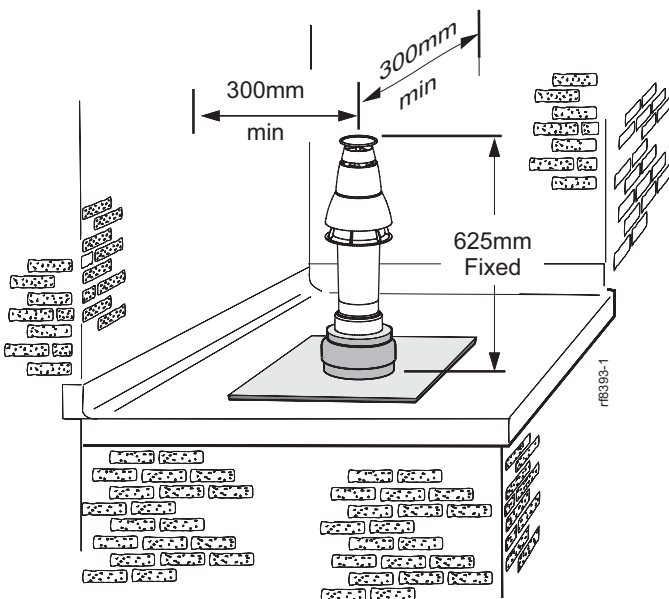

**Flat roof - with structure**

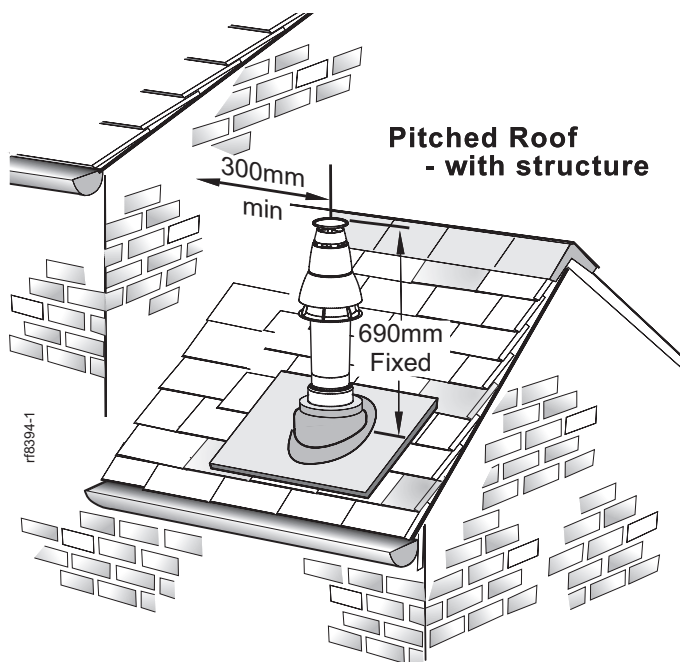

**Pitched Roof - with structure**

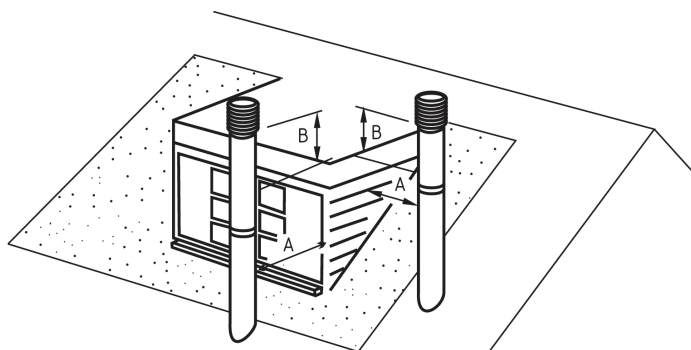

If chimney penetrates dotted area such that A is less than 300mm, B shall not be less than 300mm.

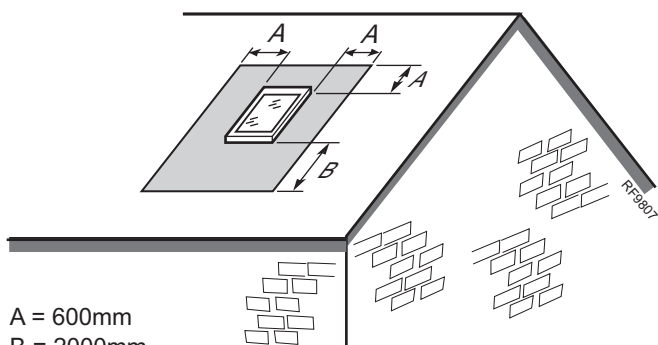

A = 600mm  
B = 2000mm

The flue terminal shall not penetrate the shaded area of the roof  
**Pitched roof - with velux window or opening**

Where two or more vertical fanned draught chimney configurations terminate in close proximity at the same height, they shall be separated by at least 300mm. Where any one vertical outlet is more than 300mm above the other, then they shall be separated by at least 1500mm.

Where any vertical fanned draught chimney configuration outlet is within 2000mm measured horizontally of an opening window, then it shall be at least 300mm above the opening.

**Note.**

The equivalent flue length resistance of the elbow kits are:

90° elbow kit = 1m

45° elbow kit = 0.6m

## 2.13 ASSEMBLING THE ROOF FLUE KIT

Determine the correct height that the flue should terminate above the roof. If after calculating or measuring the overall flue height from the top of the boiler, it is necessary to cut both pipes of assembly A, then ensure they are cut equally leaving the inner flue tube longer than the outer air tube as supplied.

Ensure the cut pipe ends are free from any burrs.

1. Position the roof flashing plate (supplied separately) over the hole cut in the roof and insert flue terminal from the roof end.

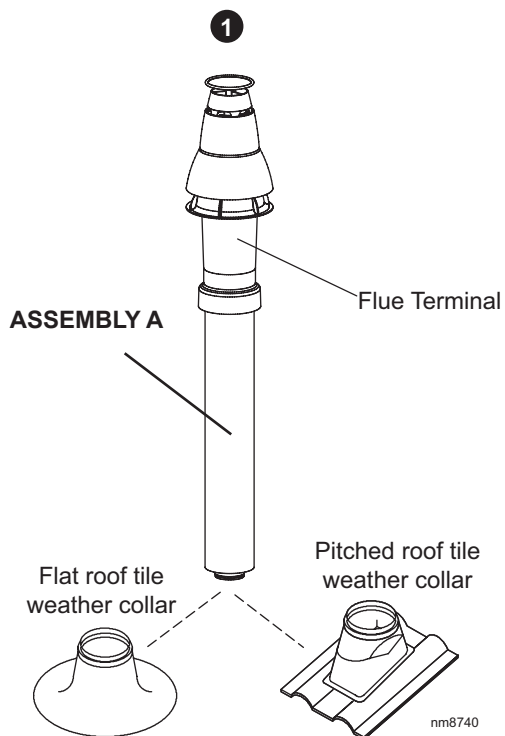
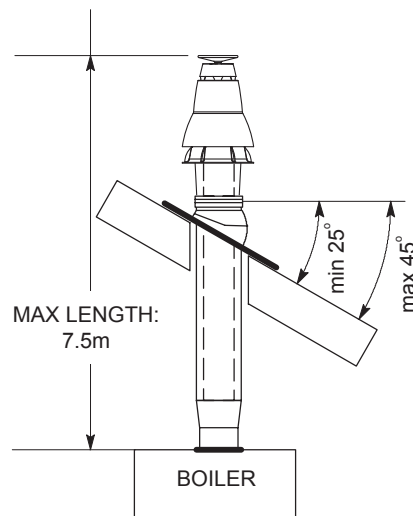

2. Fit the vertical connector (supplied in kit) in accordance with the instructions provided with the vertical connector kit.
3. Secure the vertical connector by applying downward pressure on the connector.
4. Position the clamp on the top face of the flue manifold and push it horizontally backwards. Locate both clamp lugs into the flue manifold and secure to the flue manifold with the M5 retaining screw.
5. Push extension duct (if required (supplied separately)) into vertical connector.

**Note.** Ensure turret sample points are servicable and all caps and plugs are fitted. Fill the condensate trap/siphon with water.

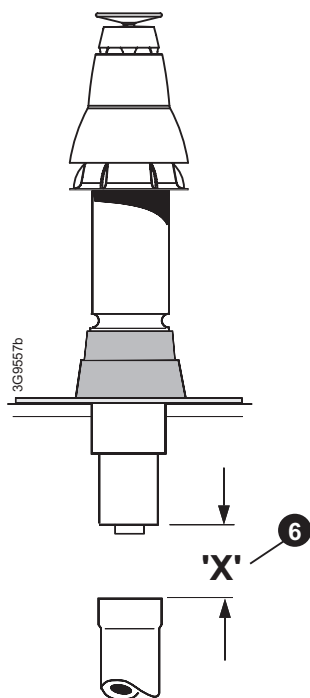
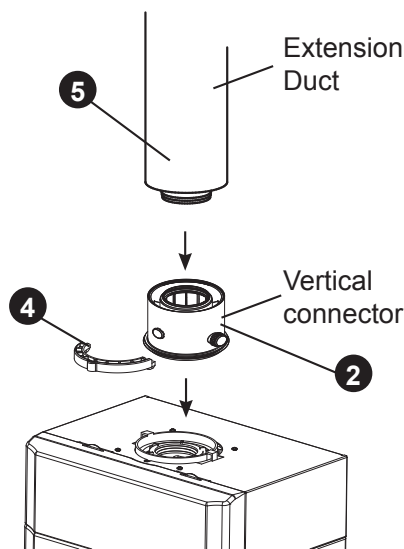

6. If the last extension duct requires cutting, measure 'X', the distance (outer ducts), between the duct and the terminal and add 100 mm to this dimension. This gives the length of the last extension duct.

**Note.** Check the position of the inner flue duct relative to the outer duct on the assembled extension duct(s) and ensure the terminal flue duct is cut longer than the air duct to ensure engagement in the final flue duct seal.

7. Finally ensure the roof flashing plate is correctly sealed to the roof.

2.14 CONDENSATE DRAIN

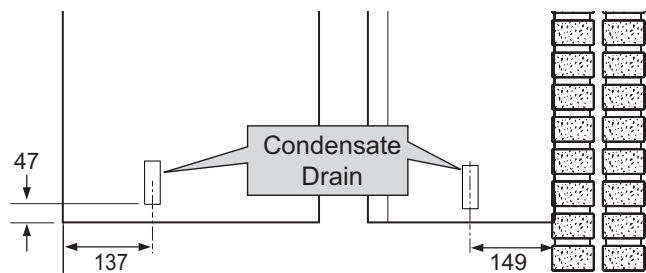

This appliance is fitted with a siphonic 75mm condensate trap system that requires filling before operating the appliance for the 1st time or after maintenance.

All condensate pipework should conform to the following:

- Where a new or replacement boiler is being installed, access to an internal 'gravity discharge' termination should be one of the main factors considered in determining boiler location.
- Plastic with push fit or solvent connections.
- Internal plastic pipe work a minimum of 19mm ID (typically 22mm OD).
- External plastic pipe must be a minimum of 30mm ID (typically 32 OD) before it passes through the sleeved wall.
- All horizontal pipe runs must fall a minimum of 45mm per metre away from the Boiler.
- External & unheated pipe work should be kept to a minimum and insulated with Class "O" waterproof pipe insulation.
- All installations must be carried out in accordance to the relevant connection methods as shown in the "Condensate installation diagrams" & BS6798:2009.
- Pipe work must be installed so that it does not allow spillage into the dwelling in the event of a blockage (through freezing).
- All internal burrs should be removed from the pipe work and any fittings.

In order to minimise the risk of freezing during prolonged very cold spells, one of the following methods of terminating condensate drainage pipe should be adopted.

**Internal Drain Connections**

Wherever possible, the condensate drainage pipe should be routed to drain by gravity to a suitable internal foul water discharge point such as an internal soil and vent stack or kitchen or bathroom waste pipe etc. See Figs 1 and 2.

**Condensate Pump**

Where gravity discharge to an internal termination is not physically possible or where very long internal pipe runs would be required to reach a suitable discharge point, a condensate pump of a specification recommended by the boiler or pump manufacturer should be used terminating into a suitable internal foul water discharge point such as an internal soil and vent stack or internal kitchen or bathroom waste pipe etc. (fig 3).

**External Drain Connections**

The use of an externally run condensate drainage pipe should only be considered after exhausting all internal termination options as described previously. An external system must terminate at a suitable foul water discharge point or purpose designed soak away. If an external system is chosen then the following measures must be adopted:

The external pipe run should be kept to a minimum using the most direct and "most vertical" route possible to the discharge point, with no horizontal sections in which condensate might collect.

- For connections to an external soil/vent stack see Fig 4. Insulation measures as described should be used.
- When a rainwater downpipe is used, an air break must be installed between the condensate drainage pipe and the downpipe to avoid reverse flow of rainwater into the boiler should the downpipe become flooded or frozen, see Fig 5.
- Where the condensate drain pipe terminates in a purpose designed soak away (see BS 6798) any above ground condensate drain pipe sections should be run and insulated as described above. See Fig 6.
- Where the condensate drain pipe terminates over an open foul drain or gully, the pipe should terminate below the grating level, but above water level, to minimise "wind chill" at the open end. The use of a drain cover (as used to prevent blockage by leaves) may offer further prevention from wind chill.

**Unheated Internal Areas**

Internal condensate drain pipes run in unheated areas, e.g. lofts, basements and garages, should be treated as external pipe.

Ensure the customer is aware of the effects created by a frozen condensate and is shown where this information can be found in the user manual.

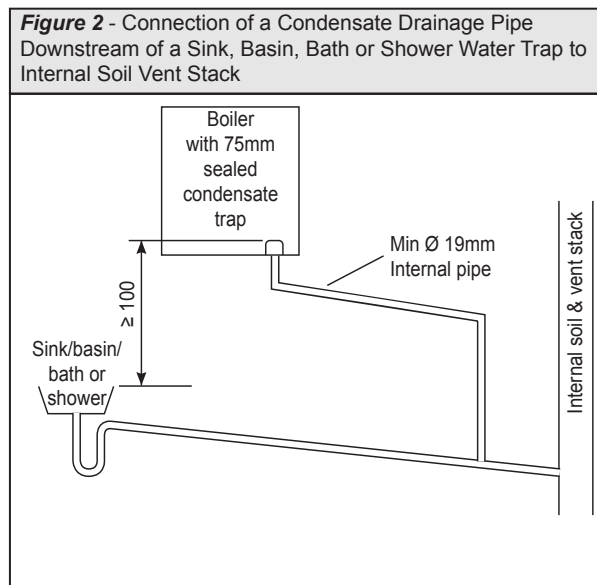
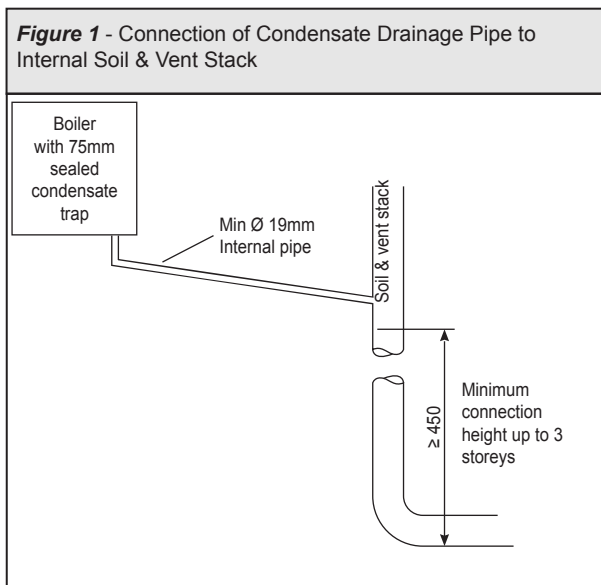

continued . . . . .

## CONDENSATE DRAIN - CONT'D.....

**Figure 3** - Connection of a Condensate Pump Typical Method (see manufacturer's detailed instructions)

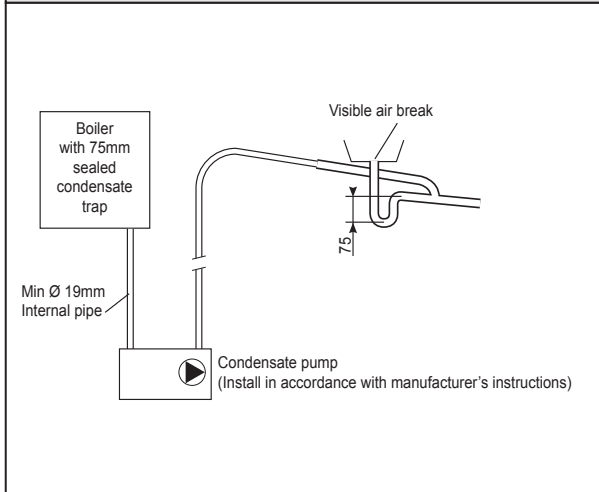

**Figure 4** - Connection of Condensate Drainage Pipe to External Soil & Vent Stack

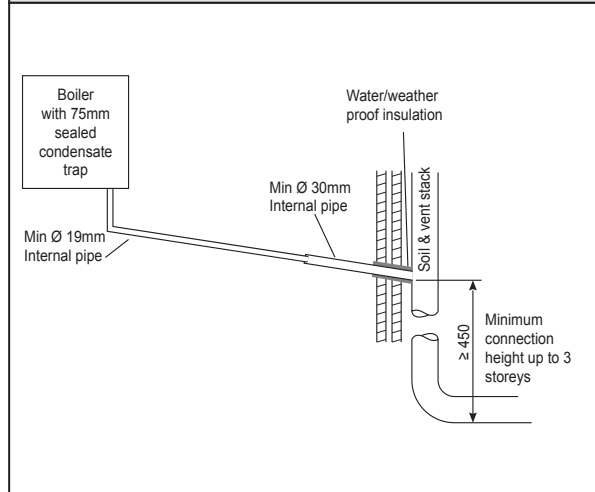

**Figure 5** - Connection of a Condensate Drainage Pipe to an External Rainwater Downpipe (only combined foul/rainwater drain)

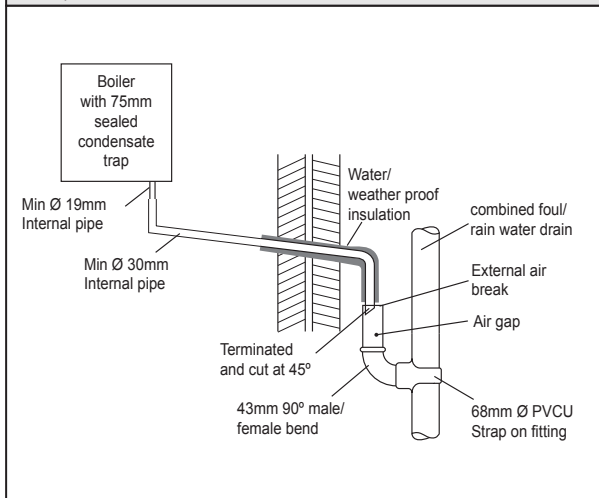

**Figure 6** - Connection of a Condensate Drainage Pipe to an External Purpose Made Soak Away.

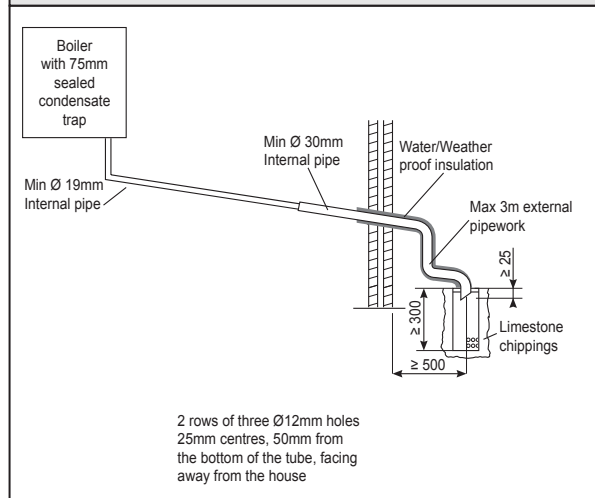

## 2.15 CONNECTIONS & FILLING

### NOTES.

Ensure all boss blanking plugs are removed before connecting hardware. Each valve must be fitted to the correct boss as shown in the picture.

Ensure each union is fitted with fibre seals provided.

Do not subject any of the isolating valves to heat as the seals may be damaged.

**Note.** The domestic hot water flow rate is automatically regulated to a maximum:

26kW = 10.7 l/m

33kW = 13.4 l/m

38kW = 15.7 l/m

### WATER CONNECTIONS CH

1. Connect the CH flow service valve (black handle) and copper tail provided in the hardware pack to the threaded boss connection provided at the lower rear of the boiler.
2. Connect the CH rtn. valve (black handle) and copper tail.

### WATER CONNECTIONS DHW

1. Fit the DHW inlet service valve (blue handle) and copper tail to the threaded boss connection ensuring the seal provided is correctly located.
2. Fit the DHW outlet pipe tail to DHW outlet connection, ensuring the seal provided is correctly located.
3. Fit the filling loop provided between the DHW inlet valve and the CH return valve.

### GAS CONNECTION

**IMPORTANT.** The gas service cock is sealed with a non-metallic blue fibre washer, which must not be overheated when making capillary connections. Refer to Section 1.17 for details of the position of the gas connection.

For additional gas supply info refer to Section 1.9 "Gas Supply".

### SAFETY VALVE DRAIN

The safety valve connection, located at the bottom right-hand side of the boiler, comprises a 15mm diameter stub pipe.

The Installer needs to provide a compression joint on the end of the stub pipe. This assists with pipe removal when servicing.

The discharge pipe should be positioned so that the discharge of water or steam cannot create a hazard to the occupants of the premises or damage the electrical components and wiring.

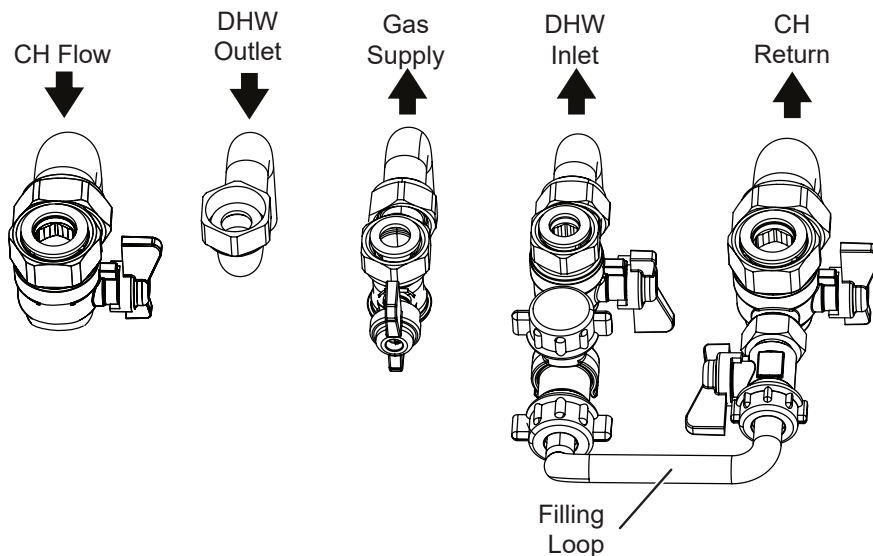
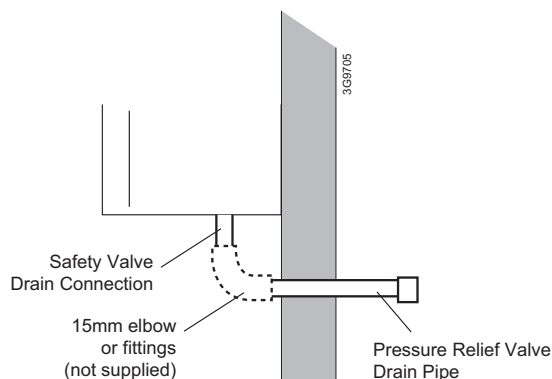

## CONNECTIONS & FILLING..... CONT'D

### FILLING

**⚠ WARNING:** Protect electrical connections from water

#### Filling

1. Ensure filling loop is connected and all washers in place.
2. Make sure that the Automatic Air Vent is set at fully OPEN.
3. Check the following isolation handles on water connections are in the horizontal filling position (blue handle on DHW inlet **A** and black handle on CH return **C**).

**Note.** The CH flow isolation valve handle **MUST** be in the vertical position to enable filling.

4. Slowly turn the filling loop handle (blue **B**) to the horizontal open position until the pressure gauge reads between 1 to 1.5 bar.
5. Once the pressure gauge dial reads between 1 to 1.5 bar turn the filling loop handle (blue **B**) back to the closed (vertical) position.
6. Turn the CH Return handle (black **C**) and the DHW Inlet handle (blue **A**) to the open (vertical) position.
7. Disconnect the filling loop from the DHW Inlet valve and fit the grey cap to the open end.
8. Fit the Plug to the free end of the filling loop.

Note open all DHW taps to ensure water is flowing freely-once satisfied close all taps.

#### Top Up

1. Ensure filling loop is connected and all washers in place.
2. Make sure that the Automatic Air Vent is set at fully OPEN.
3. Turn the DHW Inlet handle (blue **A**) to the horizontal position.
4. Slowly turn the filling loop handle (blue **B**) to the horizontal open position until the pressure gauge reads between 1 to 1.5 bar
5. Once the pressure gauge dial reads between 1-1.5 bar turn the handle (blue **B**) on the filling loop back to the closed (vertical) position.
6. Turn the DHW Inlet handle (blue **A**) to the open (vertical) position.
7. Disconnect the filling loop from the DHW Inlet valve and fit the grey cap to the open end.
8. Fit the Plug to the free end of the filling loop.

Note open all DHW taps to ensure water is flowing freely-once satisfied close all taps.

**Filling Positions shown**

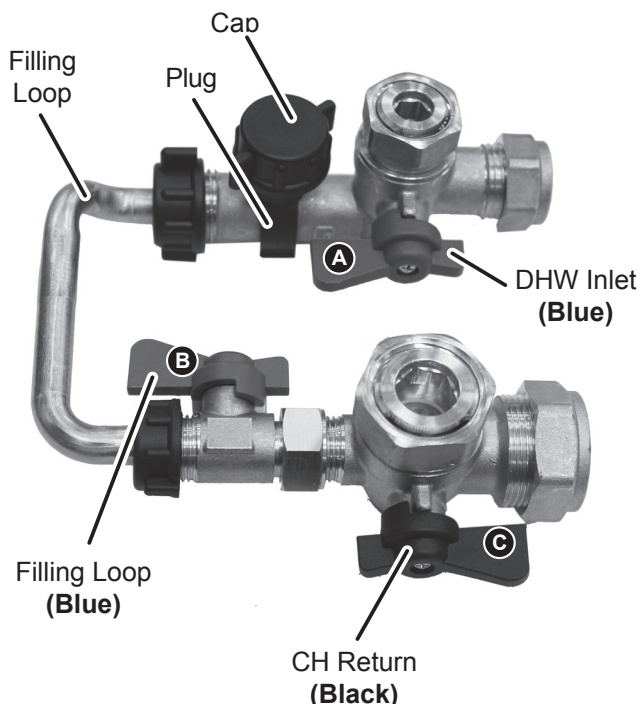

**Top Up Positions shown**

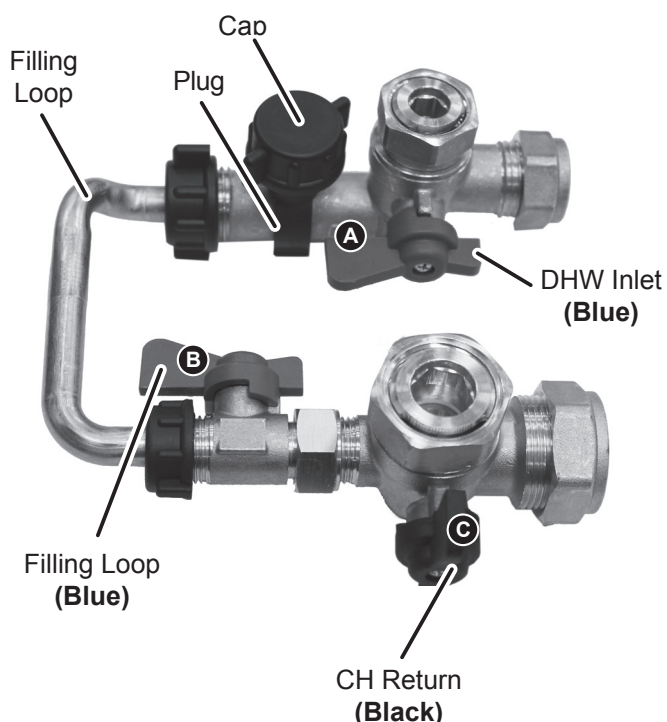

### 2.16 ELECTRICAL CONNECTIONS

**WARNING.** This appliance **MUST** be earthed.

A mains supply of 230Vac ~ 50 Hz is required.

The fuse rating should be 3A. All external controls and wiring must be suitable for mains voltage.

Wiring external to the boiler **MUST** be in accordance with the current IET (BS.7671) Wiring Regulations and any local regulations.

Wiring should be 3 core PVC insulated cable, not less than 0.75mm<sup>2</sup> (24 x 0.2mm), and to BS 6500 Table 16. For IE reference should be made to the current ETCI rules for electrical installations.

Connection must be made in a way that allows complete isolation of the electrical supply such as a double pole switch having a 3mm contact separation in both poles. The means of isolation must be accessible to the user after installation.

### 2.17 INSTALLER WIRING

The boiler comes pre-fitted with 1.8m of mains cable. This must be connected to a permanent live supply and **NOT** switched by thermostats/programmers. If the supply cord is damaged, it must be replaced by the manufacturer, service agent or similarly qualified persons in order to avoid hazard.

#### Accessing the installer wiring

1. Isolate the mains supply from the boiler.
2. Remove the front panel. Refer to section 3.2.
3. Swing down the control box into the service position, unclip and swing back the installer wiring cover and latch into the retaining clips. Refer to Section 3.8.

All of the connections can now be readily accessed, the plugs can be removed to aid wiring.

Note the cable strain relief system and grommets. Once any wiring is completed, to secure the boiler, reverse the order above.

**Note 1** *The link wire on the 230V installer room stat/timer connection gives a demand in conjunction with the OpenTherm link wire (located on the right hand side of the control box).*

**INSTALLER CONNECTIONS (LHS)**

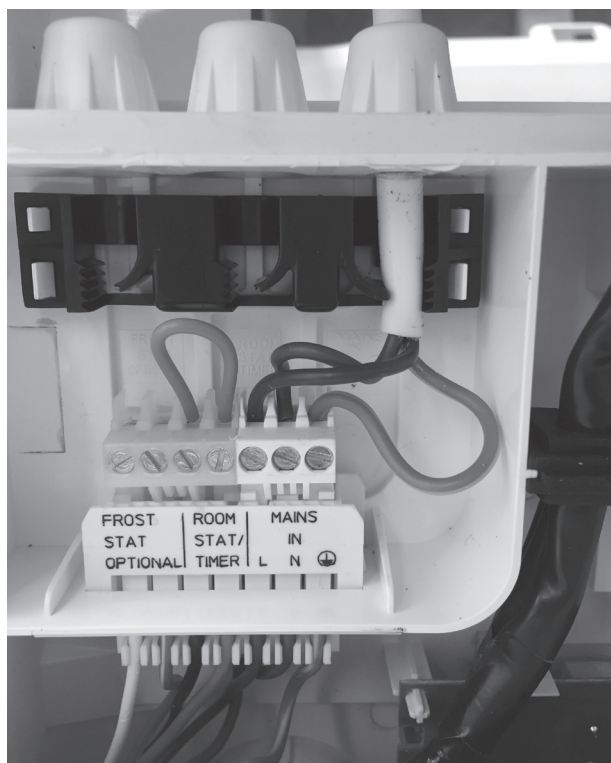

**INSTALLER CONNECTIONS (RHS)**

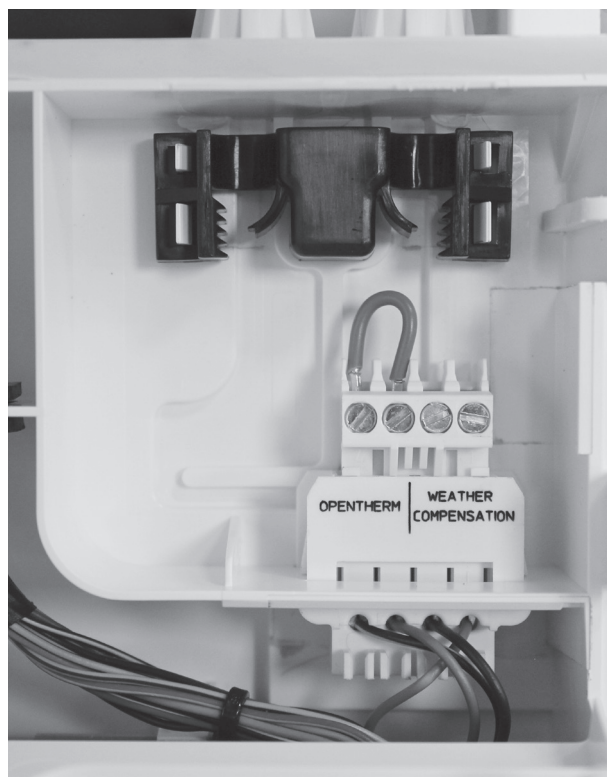

## 2.18 EXTERNAL WIRING

### External Controls – 230V 50Hz

Wiring a 230V 50Hz Room Thermostat, Diagram A (with optional timer, Diagram B)

1. Remove the link wire from the room stat/timer plug.
2. Connect the external cable from the room stat/timer across these two connections, if a general live connection is used for the room stat or timer then connect this to the fused spur, on the load side (see Diagram C).
3. If the room thermostat has compensation and requires a neutral connection, make this connection to the fused spur, on the load side.

### Optional External Controls – Extra Low Voltage

Wiring OpenTherm Room Control or other OpenTherm Master Device, Diagram D.

1. Locate the OpenTherm connection on the right hand side of the boiler installer connections area, remove the violet link wire and connect the 2 core cable from the OpenTherm device.

### Frost Protection

If parts of the pipework run outside the house or if the boiler will be left off for more than a day or so then a frost thermostat should be wired into the system.

This is usually done at the programmer, in which case the programmer selector switches are set to OFF and all the other controls MUST be left in the running position.

The frost thermostat should be sited in a cold place but where it can sense heat from the system.

Wiring a system frost thermostat, see diagrams A, B and C. Wire the frost thermostat across the two connections as shown.

**Note.** If the boiler is installed in a garage it may be necessary to fit a pipe thermostat, preferably on the return pipework.

**DIAGRAM A:**

Programmable Room Stat or Room Stat with Internal Timer

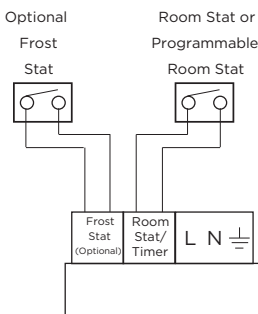

**DIAGRAM B:**

Room Stat with External Timer

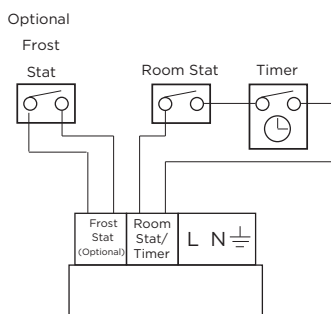

**DIAGRAM C:**

Use of General Live for Room Stat

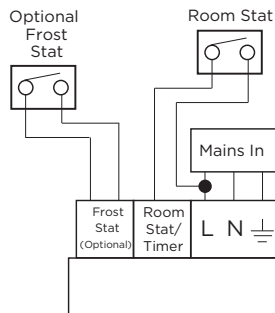

**DIAGRAM D:**

OpenTherm Device

**DO NOT CONNECT 230V TO THESE TERMINALS OR THE BOILER ELECTRONICS WILL BE DAMAGED**

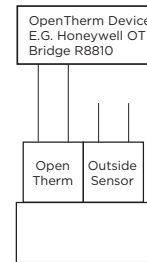

## 2.19 REPLACING PRE-FITTED MAINS CABLE

If it is necessary to use an alternative mains cable to the one pre-fitted then use the following guide.

Replacement wiring should comply with notes in Section 2.18 and be carried out by a qualified person to avoid a hazard.

1. Isolate the mains supply to the boiler.
2. Remove the front panel. Refer to Section 3.2.
3. Swing the control box down into the service position, unclip and swing back the installer wiring cover to latch into the retaining clips. Refer to Section 3.8.
4. Unplug the mains connector and release the cable from the strain relief.
5. Unscrew the L N & E connections & remove wires from connector.
6. Remove the mains cable by pulling back through the grommet .
7. Route the replacement through the grommet and re-fit in reverse order.
8. Close the installer wiring cover ensuring that it is located correctly and that the cable is retained into the strain relief as shown.
9. Swing the control box back up into the operating position and re-fit the front panel ensuring a good seal is made.

**NOTE.** When making the mains electrical connections to the boiler it is important that the wires are prepared in such a way that the earth conductor is longer than the current carrying conductors, such that if the cord anchorage should slip, the current carrying conductors become taut before the earthing conductor.

Strain Relief

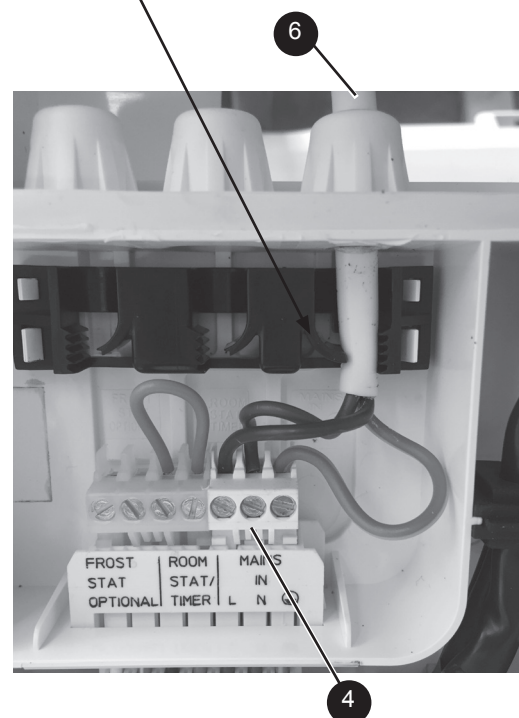



2.21 COMMISSIONING AND TESTING

**A. Electrical Installation**

1. Electrical safety checks should be carried out by a competent person.
2. ALWAYS carry out the preliminary electrical system checks, i.e. earth continuity, polarity, resistance to earth and short circuit, using a suitable test meter.
3. After wiring the boiler, all grommets in the bottom panel MUST be in place to ensure that boiler case sealing is maintained.

**B. Gas Installation**

1. The whole of the gas installation, including the meter, should be inspected and tested for tightness and purged in accordance with the recommendations of BS. 6891. In IE refer to IS.813:2002.
2. Purge air from the gas installation by the approved methods only.

**WARNING.** Whilst effecting the required gas tightness test and purging air from the gas installation, open all windows and doors, extinguish naked lights and **DO NOT SMOKE.**

**GENERAL**

**Please Note:** The combustion for this appliance has been checked, adjusted and preset at the factory for operation on the gas type defined on the appliance data plate. **DO NOT** adjust the air/gas ratio valve.

Having checked:

- That the boiler has been installed in accordance with these instructions.
- The integrity of the flue system and the flue seals, as described in the Flue Installation section.

Proceed to put the boiler into operation as follows:

**CHECK THE OPERATIONAL (WORKING) GAS INLET PRESSURE**

Set up the boiler to operate at maximum rate by opening hot tap to maximum flow.

With the boiler operating in the maximum rate condition check that the operational (working) gas pressure at the inlet gas pressure test point complies with the requirements - refer to Section 1.8 "Gas Supply".

Ensure that this inlet pressure can be obtained with all other gas appliances in the property working.

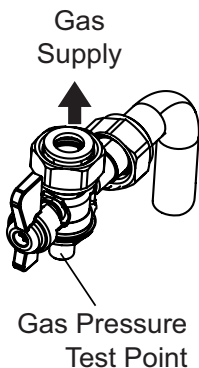

**As part of the commissioning process, the combustion of this appliance must be checked and the Benchmark Checklist completed. A flow chart to assist is provided on page 69.**

**ATTENTION !**  
**IT IS A CONDITION OF THE MANUFACTURER'S WARRANTY THAT THE BENCHMARK COMMISSIONING CHECKLIST IS FULLY COMPLETED AND LEFT WITH THE APPLIANCE**

2.22 INITIAL LIGHTING

Legend

- A. Domestic Hot Water Temperature Knob
- B. Central Heating Temperature Knob
- C. Mode Knob
- D. Boiler Status Display
- E. Burner 'on' Indicator
- F. Central Heating Economy Setting
- G. CH Flow Isolating Valve
- H. Gas Inlet Pressure Test Point
- I. Gas Service Cock
- J. DHW Inlet Valve
- K. CH Return Isolating Valve
- L. DHW Outlet
- M. Filling Loop Valve
- N. Pressure Gauge
- O. Function Button
- P. RESTART Button

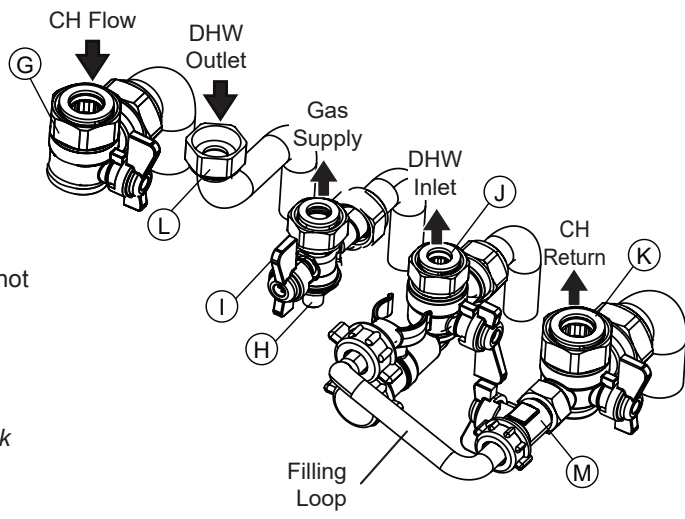
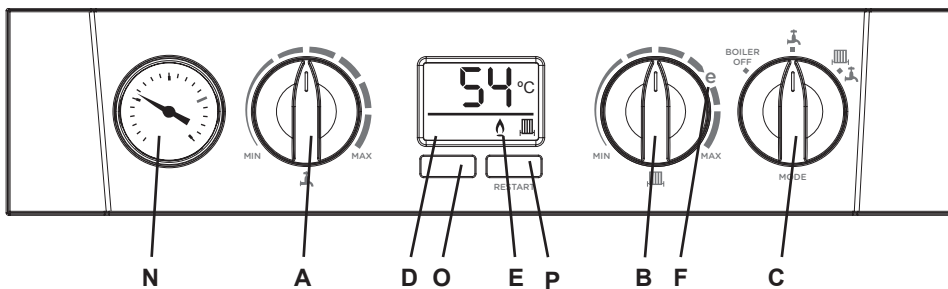

1. Check that the system has been filled and that the boiler is not airlocked. Ensure the automatic air vent cap is open.

Note.

It is important the burner is not operated before the system is fully vented of air. If it is necessary to operate the appliance pump to assist venting of the air this must be done with the gas service cock turned off.

2. Refit the boiler front panel. Refer to Section 3.2.
3. Check that the drain cock is closed and that the CH and DHW isolating valves (G,K & J) are OPEN.
4. Check that the electrical supply is OFF.
5. Check that the boiler mode knob (C) is OFF.
6. Check that the gas service cock (I) is OPEN.
7. Slacken the screw in the inlet pressure test point (H) and connect a gas pressure gauge via a flexible tube.
8. Switch the electricity supply ON and check all external controls are calling for heat.

CENTRAL HEATING

9. Set the CH temp control (B) to "MAX" and turn the mode knob (C) to 'CH'. The boiler control should now go through its ignition sequence until the burner is established.
10. If the boiler does not light then after 5 attempts the boiler will lock out and display fault code L2.

Restart the boiler (Refer to Section 2.24). The boiler will repeat its ignition sequence. If restart occurs 5 times within 15 minutes then LC will be shown.

When the burner is established the 'flame' will be shown on the display with the 'CH' indicating central heating operation and the current flow temperature shown in the 2 digit display.

DOMESTIC HOT WATER

11. With the boiler firing, set the DHW Temp Knob (A) to "MAX" and fully open a DHW tap.

The boiler should continue to run and the display should change from showing 'CH' to 'DHW'.

12. Ensure that with the boiler operating the dynamic gas pressure is able to obtain maximum output. Refer to Table 3.

IMPORTANT

The gas input to the burner is regulated by the gas valve according to the air flow produced by the fan. It is NOT user-adjustable. Any interference to sealed settings on the gas valve will adversely affect operation and render our warranty void.

For additional gas supply information refer to "Gas Supply" Section 1.8.

13. Turn off the DHW tap.
14. Remove gas pressure gauge, tighten inlet pressure test point and check for gas tightness.

**THE DISPLAY**

The user control has one display to inform the user about the status of the boiler. The LCD Display shows the status of the flame. If no flame is detected the flame symbol will not be visible. When the flame is detected the flame symbol will be visible permanently.

Below is a list with display function in normal operation.

- Standby, no demand for heat present.
- ▣ Boiler is active for central heating.
- ♁ Boiler is active for domestic hot water.
- FP Boiler is active for boiler frost protection.
- L Boiler is in lockout for a specific error. Display will show a number after the "L" to indicate which error is detected.
- F Boiler has a fault for a specific error. Display will show a number after the "F" to indicate which error is detected.

**Note:** Boiler frost protection - boiler operates if the ambient temperature is below 5°C until it reaches 19°C.

Note. The boiler incorporates a fan overrun cycle which MUST NOT be prematurely interrupted by isolation of the mains electricity supply.

**2.23 GENERAL CHECKS**

**Make the following checks for correct operation:**

1. Fully open all DHW taps in turn and ensure that water flows freely from them.

The display should show



'' when the burner lights

2. Close all taps except the furthest one from the boiler and check that the boiler is firing at maximum rate.

This is factory set to give a DHW temperature rise of approximately 35°C at the flow rate stated in Section 1.2.

3. Reduce the DHW draw-off rate to about 3 l/min and check that the boiler modulates to deliver DHW at approximately 65°C.

4. Close the DHW tap and check that the main burner extinguishes. The pump should overrun for 60 seconds.

When the pump stops the display sequence should read:



**Note.** On systems in excess of 2 bar inlet pressure a water pressure governor may be required to prevent water noise.

**CENTRAL HEATING (CH) & DOMESTIC HOT WATER (DHW) MODE.**

1. Ensure that the CH external controls are calling for heat.

**The display should show:**



2. Fully open a DHW tap and check that hot water is delivered.

The display should show



3. **Gas Rate**

Check the boiler gas rate when the boiler is at full DHW output.

Check at the gas meter, with no other appliance in use. Refer to Tables 2 & 3 for gas rates.

4. Close the DHW tap.

5. Set the central heating external controls to OFF. The burner should go off and the pump continue to run for two minutes.

The display should read:



6. Check the correct operation of the timer (if fitted) and all other system controls. Operate each control separately and check that the main burner responds.

**WATER CIRCULATION SYSTEM**

1. With the system COLD, check that the initial pressure is correct to the system design requirements.

For pre-pressurised systems, this should be 1.0 bar.

2. With the system HOT, examine all water connections for soundness. The system pressure will increase with temperature rise but should not exceed 2.5 bar.

3. With the system still hot, turn off the gas, water and electricity supplies to the boiler and drain down to complete the flushing process.

**Note:** A flushing solution should be used during the flushing procedure. Flushing solutions: Fernox Superfloc, Sentinel X300 (new systems) or X400 (existing systems). Refer to Section 1.20.

4. Refill and vent the system, add inhibitor (refer to section 1.19), clear all air locks and again check for water soundness.

5. Reset the system initial pressure to the design requirement.

6. Balance the system. Refer to Section 1.19.

7. Check the condensate drain for leaks and check that it is discharging correctly.

8. Finally, set the controls to the User's requirements.

**Note:** The pump will operate briefly as a self-check once every 24 hours in the absence of any system demand.

**WATER TEMPERATURES**

Temperatures can be selected using the CH and DHW thermostats.

Knob Setting	CH Flow Temp °C	DHW Outlet Temp °C
Max	80	65
Min	30	40

Due to system variations and seasonal temperature fluctuations DHW flow rates/temperature rise will vary, requiring adjustment at the draw off tap : the lower the rate the higher the temperature, and vice versa.

## SECTION 2 - INSTALLATION

### 2.24 RESTART PROCEDURE

To restart the boiler, press the RESTART button (I).

#### Legend

- A. Domestic Hot Water Temperature Knob
- B. Central Heating Temperature Knob
- C. Mode Knob
- D. Boiler Status Display
- E. Burner 'on' Indicator
- F. Central Heating Economy Setting
- G. Pressure Gauge
- H. Function Button
- I. RESTART Button

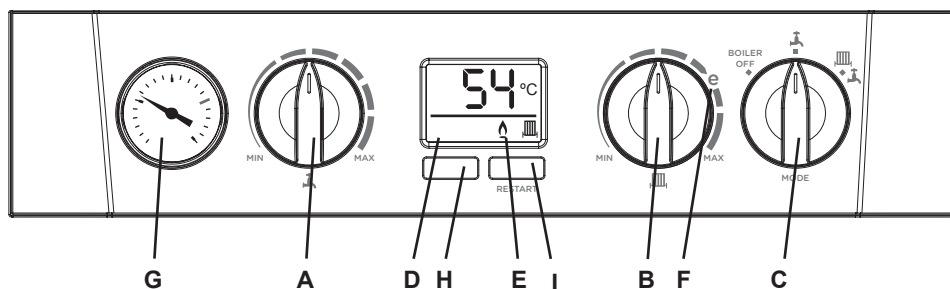

### 2.25 ACCESSING THE INSTALLER MODE

To access Installer Mode press the Function and "RESTART" Buttons together for more than 5s.

1. The last 3 faults will be shown  
See Section 4.1 for Fault Code descriptions
2. "SL" will be shown  
To run the burner at minimum rate press "RESTART", otherwise press the Function button.
3. "SH" will be shown  
To run the burner at maximum rate press "RESTART", otherwise press the Function button.
4. "VF" will be shown  
To activate the venting function press "RESTART", otherwise press the Function button.  
The venting function runs for 5 minutes before automatically returning to normal operation  
The diverter valve moves between CH and DHW every 30s
5. "dU" will be shown  
To move the diverter valve to mid-position for replacement press "RESTART", otherwise press Function button.
6. "P1" will be shown  
To set the minimum CH pump speed to 100% press "RESTART", otherwise press the Function button.
7. "P7" will be shown  
To set the minimum CH pump speed to 70% (default) press "RESTART", otherwise press the Function button.
8. "FL" will be shown  
This feature is not required on this appliance. Press the function button.
9. "SE" will be shown  
For service timer function refer to separate instructions. Press the function button to exit.

### 2.26 HANDING OVER

After completing the installation and commissioning of the system the installer should hand over to the householder by the following actions:

1. Hand the User Instructions to the householder and explain his/her responsibilities under the relevant national regulations.
2. Explain and demonstrate the lighting and shutting down procedures.
3. The operation of the boiler and the use and adjustment of all system controls should be fully explained to the householder, to ensure the greatest possible fuel economy consistent with the household requirements of both heating and hot water consumption.  
Advise the User of the precautions necessary to prevent damage to the system and to the building, in the event of the system remaining inoperative during frosty conditions.
4. Explain the function and the use of the boiler heating and domestic hot water controls.  
Explain that due to system variations and seasonal temperature fluctuations DHW flow rates/temperature rise will vary, requiring adjustment at the draw off tap. It is therefore necessary to draw the user's attention to the section in the User Instructions titled "Control of Water Temperature" and the following statement:  
**"Additionally, the temperature can be controlled by the user via the draw-off tap: the lower the rate the higher the temperature, and vice versa".**
5. Explain the function of the boiler fault mode.  
Emphasise that if a fault is indicated refer to "Fault Codes" in the User Guide.
6. Explain and demonstrate the function of time and temperature controls, radiator valves etc., for the economic use of the system.
7. If a timer is fitted draw attention to the timer User Instructions and hand them to the householder.
8. Loss of system water pressure  
Explain that the dial on the boiler indicates the central heating system pressure and that if the normal COLD pressure of the system is seen to decrease over a period of time then a water leak is indicated. Explain the re-pressurising procedure and if unable to re-pressurise or if the pressure continues to drop a registered local heating installer should be consulted.
9. Explain Boiler restart procedure.
10. After installation and commissioning please complete  Commissioning Checklist before handover to the customer. For IE, it is necessary to complete a "Declaration of Conformity" to indicate compliance to I.S. 813:2002.

#### IMPORTANT

11. A comprehensive service should be carried out ANNUALLY.  
Stress the importance of regular servicing by a Gas Safe Registered Engineer. In IE servicing work must be carried out by a Registered Gas Installer (RGII).
12. Inform the householder of the guarantee/registration found within the envelope pack and the requirement to register it to receive the full benefit of the warranty.

## 3.1 SERVICING SCHEDULE

For the very latest copy of literature for specification & maintenance practices, visit our website [idealheating.com](http://idealheating.com), where you will be able to download the relevant information.

**WARNING.** Always turn OFF the gas supply at the gas service cock, and switch OFF and disconnect the electricity supply to the appliance before servicing.

**Combustion testing must be carried out by a competent person using a combustion analyser conforming to BS7927.**

To ensure the continued safe and efficient operation of the appliance it is recommended that it is checked at regular intervals and serviced as necessary. The frequency of servicing will depend upon the installation condition and usage but should be carried out at least annually.

It is the law that any service work must be carried out by a Gas Safe Registered Engineer. In IE service work must be carried out by a Registered Gas Installer (RGI).

**Note.** In order to carry out either servicing or replacement of components the boiler front panel must be removed. Refer to Section 3.2.

### PRELIMINARY INSPECTION

1. Light the boiler and carry out a pre-service check, noting any operational faults (refer to appropriate fault finding chart as necessary).
2. Check the flue terminal (and terminal guard if fitted) is undamaged and clear of any obstruction.
3. Check combustion by connecting the flue gas analyser to the flue gas sampling point as shown in the diagram and measure CO and CO<sub>2</sub> at maximum rate. To set the boiler to Maximum and Minimum heat inputs see page 68. Repeat at minimum rate.

If the CO / CO<sub>2</sub> ratio is greater than 0.004 please proceed to "Cleaning Procedure".

If the CO / CO<sub>2</sub> ratio is less than 0.004 please proceed to "Check Procedure".

### CHECK PROCEDURE

1. Check all water and gas joints for signs of leakage. Remake any suspect joints ensuring a gas tightness check is carried out if applicable and the water system is correctly refilled, vented and re-pressurised.
2. Proceed to "IMPORTANT".

### CLEANING PROCEDURE

1. Clean the main burner. Refer to Section 3.4.
2. Clean the heat exchanger & condensate trap/siphon. Refer to Section 3.5 & 3.6.
3. Check the main injector for blockage or damage. Refer to Section 3.3.

ALSO IF THE DHW FLOW RATE IS IN QUESTION:

4. Check the DHW filter for blockage.
5. The cleaning procedures are covered more fully in Sections 3.3 - 3.7 and MUST be carried out in sequence.
6. Proceed to "IMPORTANT".

**Do not operate the boiler if the front panel is not fitted.**

### IMPORTANT

1. If, for any reason, the condensate trap/siphon has been removed, ensure the trap is refilled with water before re-assembling.
2. After completing the servicing or exchange of components always ensure all gas valve connections are gas tight with a gas soundness check up to the gas control valve.
3. When work is complete the front panel MUST be correctly refitted, ensuring that a good seal is made.
4. Complete the service section in the Benchmark Commissioning Checklist.

### GENERAL

**Please Note:** During routine servicing, and after any maintenance or change of part of the combustion circuit, the following must be checked:

- The integrity of the flue system and the flue seals,
- The integrity of the boiler combustion circuit and the relevant seals
- The operational (working) gas inlet pressure at maximum rate
- The gas rate
- The combustion performance

### COMPETENCE TO CARRY OUT THE COMBUSTION PERFORMANCE CHECK

**Please Note:** BS 6798:2009 Specification for installation and maintenance of gas-fired boilers of rated input not exceeding 70kW net advises that:

- The person carrying out a combustion measurement should have been assessed as competent in the use of a flue gas analyser and the interpretation of the results
- The flue gas analyser used should be one meeting the requirements of BS7927 or BS-EN50379-3 and be calibrated in accordance with the analyser manufacturer's requirements, and
- Competence can be demonstrated by satisfactory completion of the CPA1 ACS assessment, which covers the use of electronic portable combustion gas analysers in accordance with BS7967, Parts 1 to 4

Ensure all gas valve connections are gas tight with a gas soundness check up to the gas control valve.

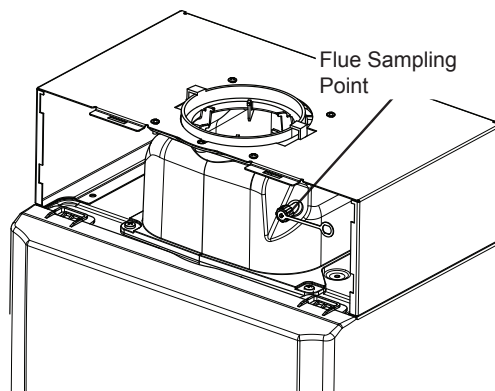

3.2 BOILER TOP POD DOOR & FRONT PANEL REMOVAL / REPLACEMENT

POD DOOR

1. Squeeze the two tabs forward and lift the pod door upwards to remove.
2. Replace and refit in reverse order.

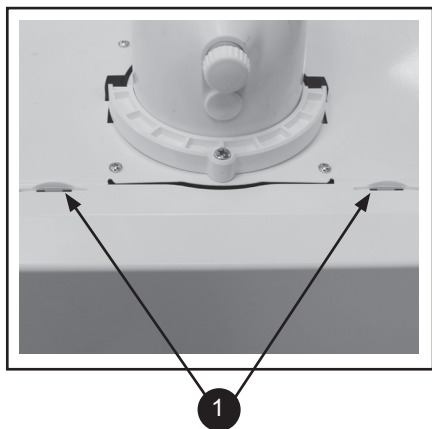

FRONT PANEL REMOVAL

1. Loosen the two screws retaining the front panel.
2. Pull the two clips down to disengage and pull panel forward and upward and remove.

FRONT PANEL REPLACEMENT

3. Hook the panel onto the top retaining clips.
4. Push the panel until the 2 bottom spring clips engage ensuring the 3 control knobs line up with the holes in the front panel.
5. Re-tighten the two retaining screws.

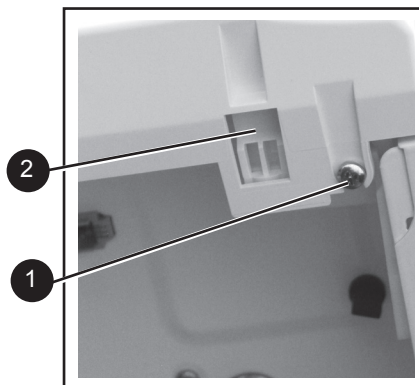

view from bottom of boiler

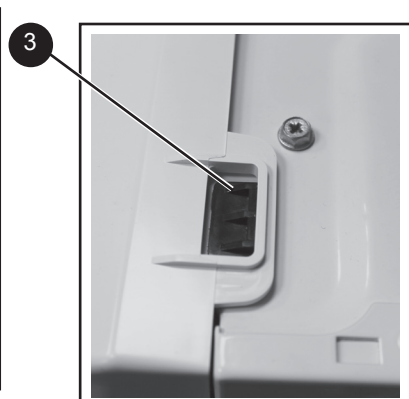

view from top of boiler

SERVICING

3.3 FAN AND VENTURI ASSEMBLY REMOVAL AND CLEANING

1. Disconnect the electrical leads from the fan.
2. Remove the clip from the gas control valve outlet and ease the pipe upwards, rotate and then ease down to remove.
3. Remove the extended nut on the fan mounting bracket.
4. Lift off fan and venturi assembly.
5. Inspect the injector nozzle for debris. If damaged, replace the injector.
6. Inspect fan outlet sealing gasket and replace if necessary.

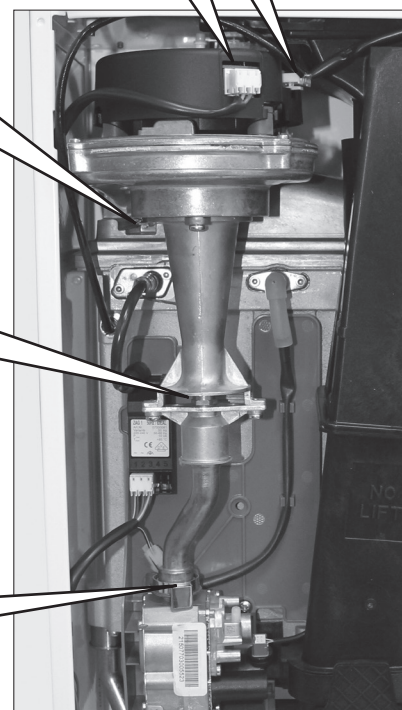
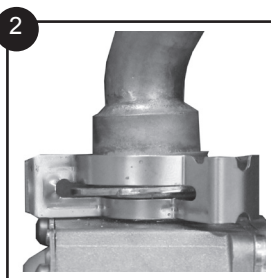
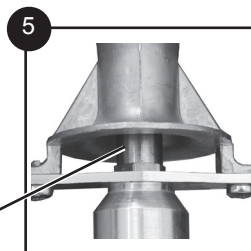
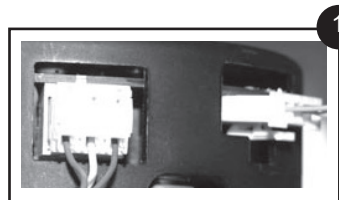
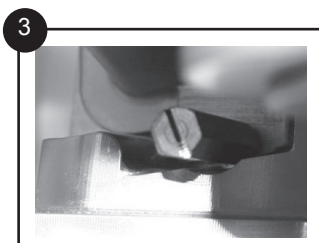

### 3.4 BURNER REMOVAL AND CLEANING

1. Ensure the sump is fully drained.
2. Undo the two screws and remove the sump cover retaining the lower flue manifold.
3. Lift the manifold to clear the bottom sealing gasket and remove manifold.
4. Remove the 2 burner front fixing screws and remove the 2 rear extended nuts by at least ten turns.
5. Lift off the burner from the combustion chamber. To facilitate the removal, hold the DHW flexible pipe against the front of the expansion vessel while withdrawing the burner.

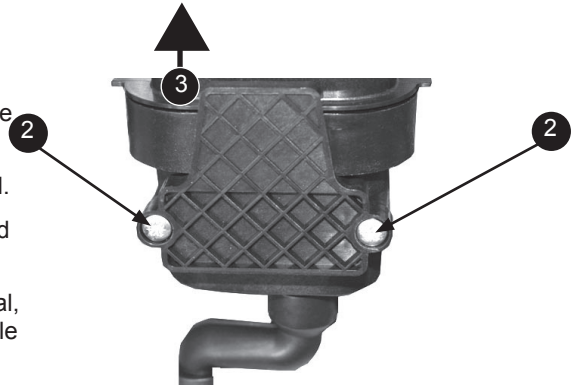

#### IMPORTANT

The burner head is a ceramic plaque construction. Care must be taken to ensure that **the burner is not placed down upon its face** as this may cause damage to the ceramic.

6. Brush off any deposits that may be on the ceramic with a SOFT brush.
7. Inspect the sealing gasket around the burner for any signs of damage. Replace as necessary.

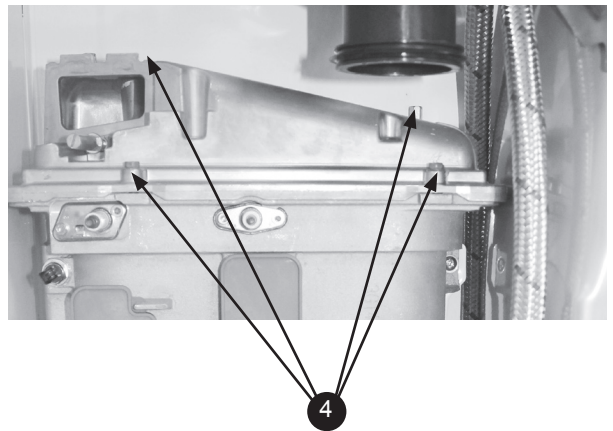
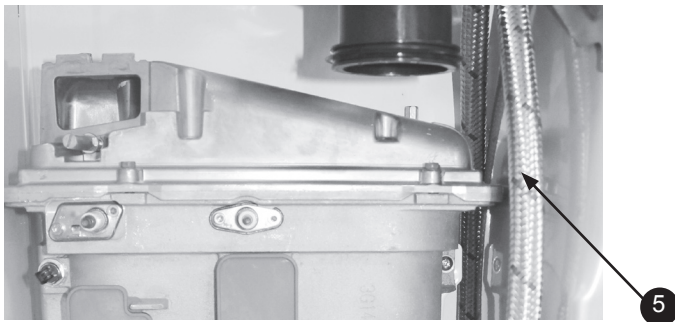

### 3.5 CLEANING THE CONDENSATE TRAP/SIPHON

1. Pull off the rubber pipe at the sump drain.
2. Disconnect the condensate drain pipe.
3. Turn the siphon clockwise to disengage and lift to remove.
4. Clean siphon with water.
5. Re-assemble in reverse order.
6. When re-assembling ensure the trap is full of water.

**Note.** Keep siphon upright when removing

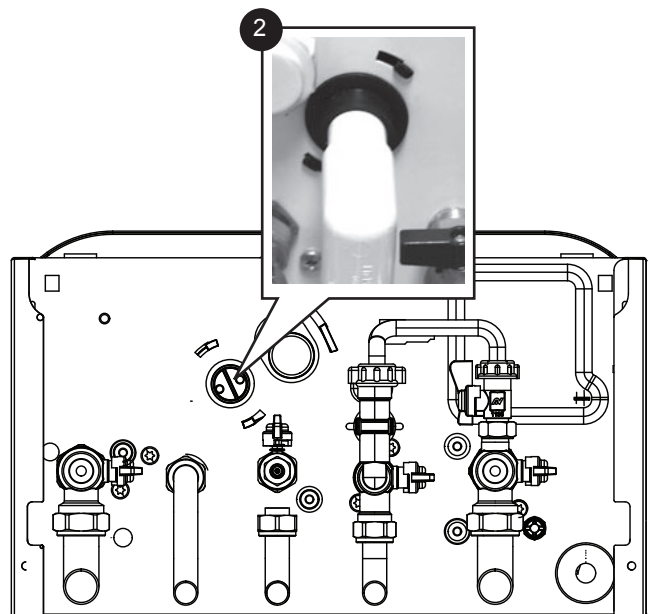

### 3.6 CLEANING THE HEAT EXCHANGER

**Note:** Ensure the condensate trap/siphon is fully drained before cleaning. Refer to Section 3.18.

1. Remove ignition and flame detection electrodes. Refer to Sections 3.13 & 3.14.
2. It is advisable to replace the sump cover prior to the water flush process.
3. Thoroughly flush the heat exchanger by pouring water into the top of the combustion chamber ensuring the full top area is covered.
4. Remove the sump cover and clean loose deposits from the sump.
5. Inspect the ignition and detection electrodes. Ensure that they are clean and in good condition - replace if necessary.
6. Re-fit the ignition and flame detection electrodes, ensuring that both earth tabs are fitted to ignition electrode.
7. Check that the ignition and detection gaps are correct. Refer to Sections 3.13 & 3.14.

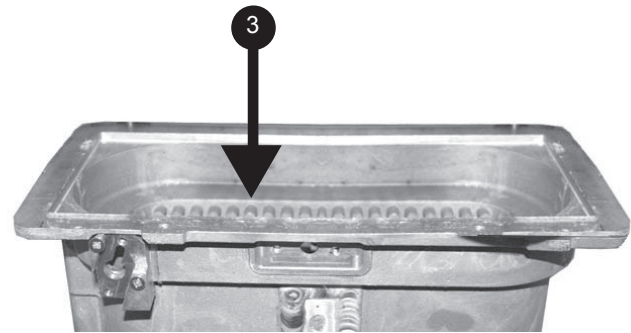
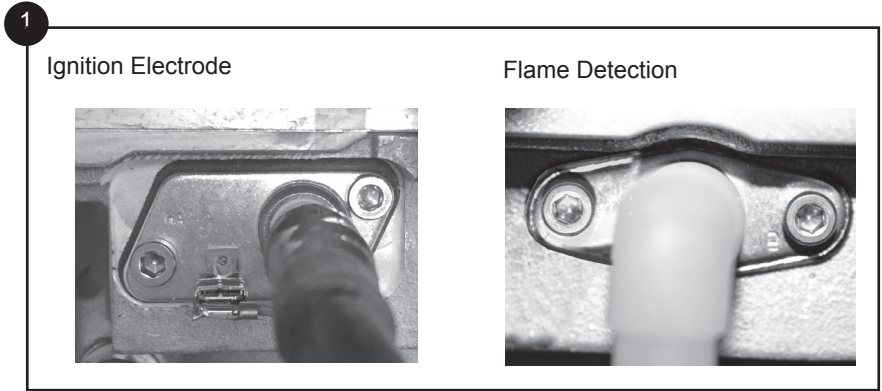

### 3.7 REASSEMBLY

Reassemble the boiler in the following order:

1. Ensure that the condensate trap/siphon is full of water.
2. Refit the burner ensuring the sealing gasket is correctly positioned and free from damage (tighten the 4 fixing screws in the sequence shown below).
3. Refit the fan / venturi assembly ensuring the retaining tabs are correctly positioned and the sealing gasket is correctly positioned and free from damage.
4. Reconnect the fan electrical leads.
5. Remove the sump cover and refit the lower flue manifold as shown.
6. Refit the sump cover.
7. Refit the boiler front panel.
 

**IMPORTANT.** Ensure that the boiler front panel is correctly fitted and that a good seal is made.
8. Swing the control box back into its working position and secure.
9. Turn on the gas supply at the gas service cock.
10. Reconnect the electrical supply.

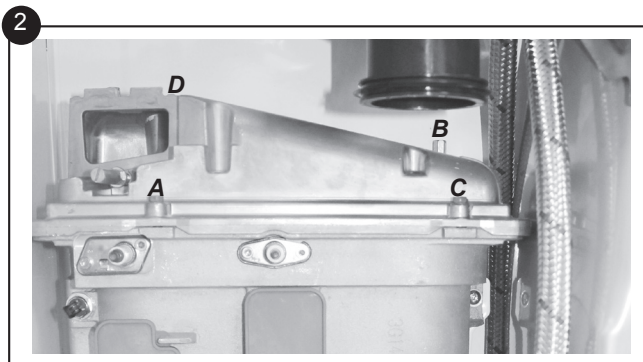

### 3.8 REPLACEMENT OF COMPONENTS

#### GENERAL

#### When replacing ANY component

1. Isolate the electricity supply.
2. Turn off the gas supply.
3. Remove the top pod door and boiler front panel. Refer to Section 3.2.
4. Swing the control box down into its servicing position.

After replacing ANY component check operation of the boiler, including gas soundness, gas rate and combustion test.

#### IMPORTANT.

Ensure all gas valve connections are gas tight with a gas soundness check up to the gas control valve.

When work is complete, the front panel must be correctly refitted - ensuring that a good seal is made.

#### Notes.

1. In order to assist fault finding, the control panel has an LCD diagnostic display. The key to boiler fault conditions is shown in Section 4.1.
2. In order to replace components in Sections 3.20, 3.22 - 3.33 it is necessary to drain the boiler. Refer to Section 3.21.

**THE BOILER MUST NOT BE OPERATED WITHOUT THE FRONT PANEL FITTED**

### 3.9 FAN REPLACEMENT

1. Refer to Section 3.8.
2. Disconnect the electrical leads from the fan.
3. Remove the clip from the gas control valve outlet.
4. Remove the extended nut retaining the fan mounting bracket.
5. Lift and remove the fan and venturi assembly.
6. Remove the screw and twist venturi anti-clockwise to remove venturi assembly, *noting the orientation of the venturi in relation to the fan body.*
7. Transfer the venturi assembly to the new fan, replacing the 'o' ring if evidence of damage or deterioration is visible.
8. Fit the new fan / venturi assembly ensuring the retaining tabs are correctly positioned and the fan outlet sealing gasket is correctly positioned and free from damage. Refit the extended nut.
9. Reassemble the boiler in reverse order, taking care not to overtighten the screw on the fan mounting bracket and ensure all gas 'o' rings are in place.
10. Check the operation of the boiler. Refer to Sections 2.22 & 2.23.

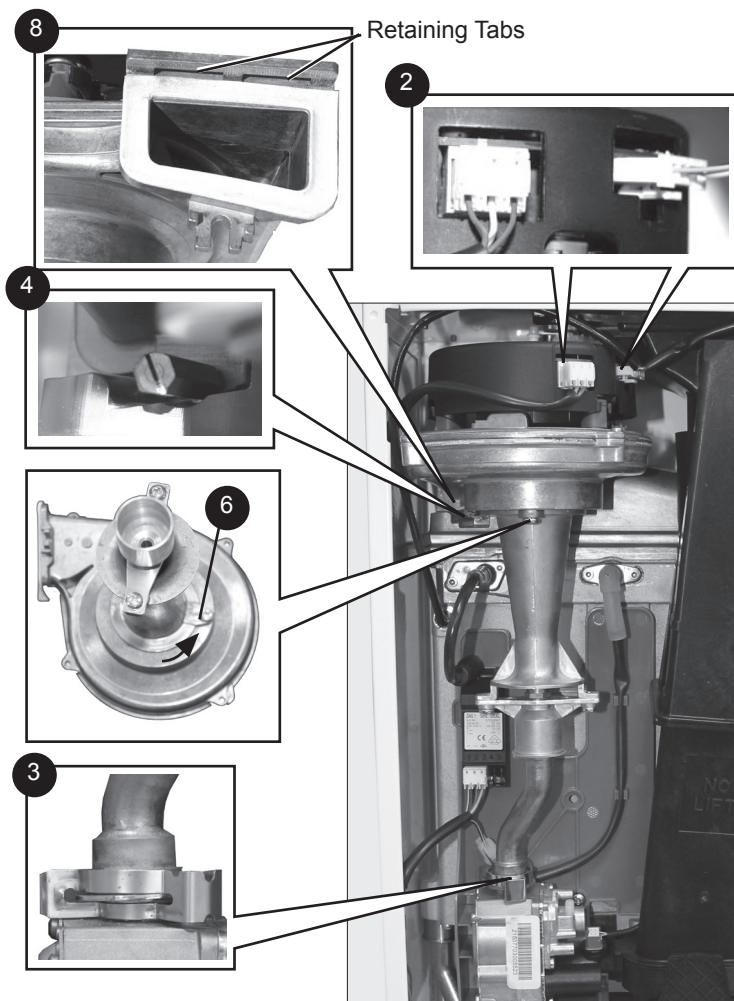

### 3.10 BURNER INJECTOR REPLACEMENT

1. Refer to Section 3.8.
2. Disconnect the electrical leads from the fan.
3. Remove the clip from the gas valve to venturi pipe and ease the pipe upwards, rotate and ease down to remove.
4. Loosen the screw retaining the fan mounting bracket.
5. Lift and remove the fan and venturi assembly.
6. Remove the 2 injector housing screws.
7. Withdraw the injector housing.
8. Fit the new injector housing complete with injector.
9. Reassemble in reverse order, ensuring that the new gas seal supplied is located correctly in the injector housing.
10. Check operation of the boiler.

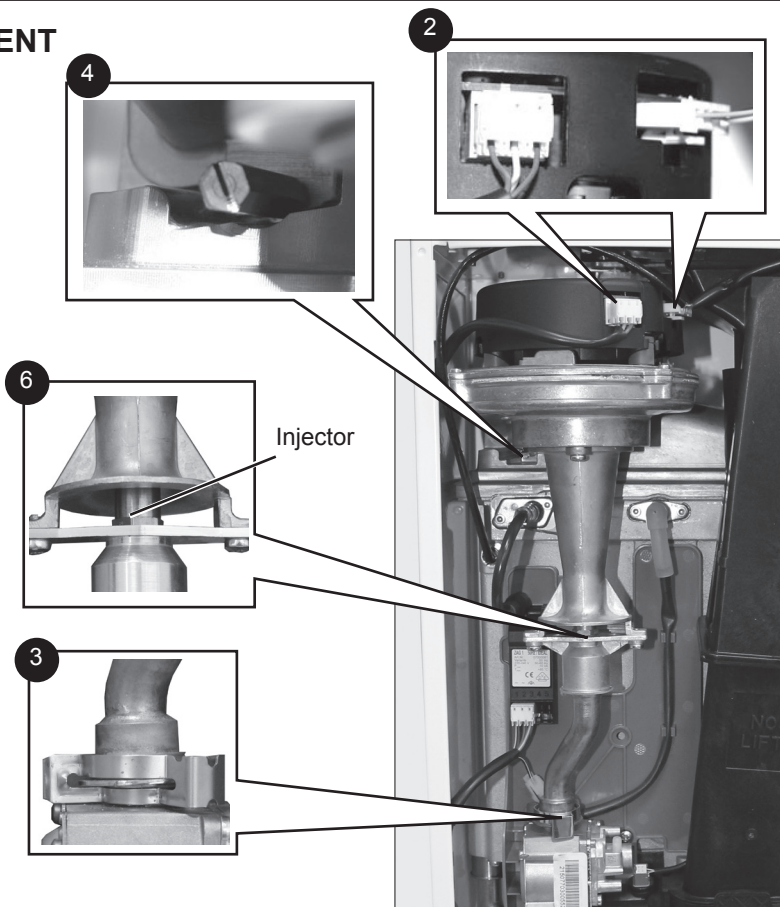

### 3.11 BURNER REPLACEMENT

1. See Section 3.8.
2. Refer to Section 3.4.
3. Remove the fan. Refer to Section 3.9.
4. Undo the two screws and remove the sump cover.
5. Lift the manifold to clear the bottom sealing gasket and remove manifold.
6. Remove the 2 front fixing screws and remove the 2 rear extended nuts.
7. Lift off the burner from the combustion chamber. To facilitate the removal, hold the DHW flexible pipe against the front of the expansion vessel while withdrawing the burner.
8. Fit the new burner, replacing any damaged or deteriorating sealing gasket.
9. Reassemble in reverse order. Refer to Section 3.7.
10. Check the operation of the boiler. Refer to Sections 2.22 & 2.23.

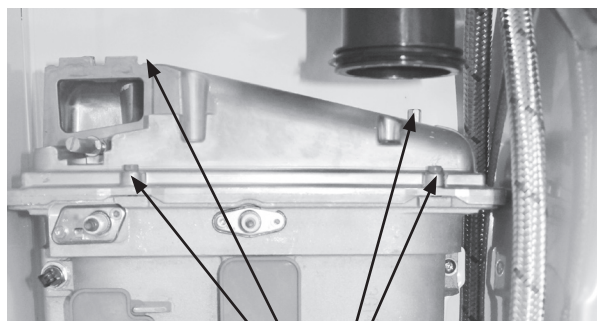
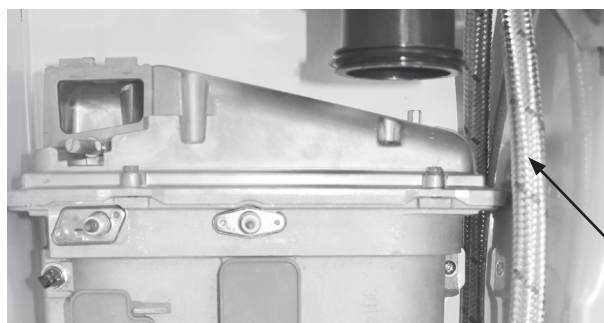
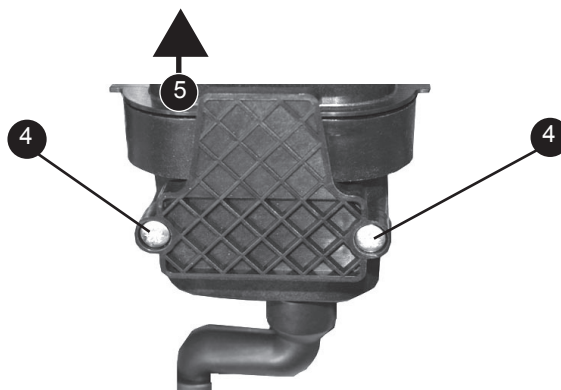

6

### 3.12 RETURN THERMISTOR RENEWAL

1. Refer to Section 3.8.
2. Unclip the return thermistor from the return pipe and withdraw it from the boiler.
3. Disconnect the electrical lead from the thermistor.
4. Reconnect the electrical lead to the new thermistor and reassemble in reverse order, ensuring that the thermistor is securely fitted to the pipe on the thermistor locator tab as shown.
5. Check the operation of the boiler.

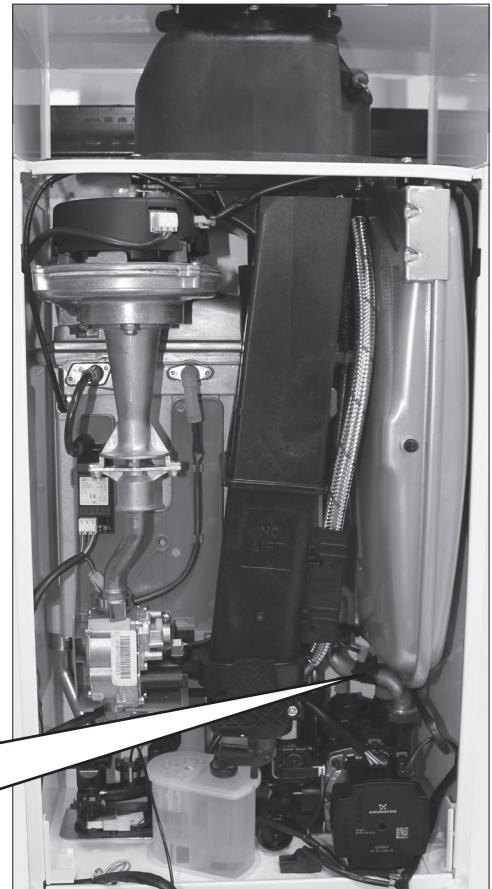
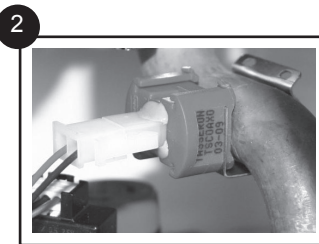
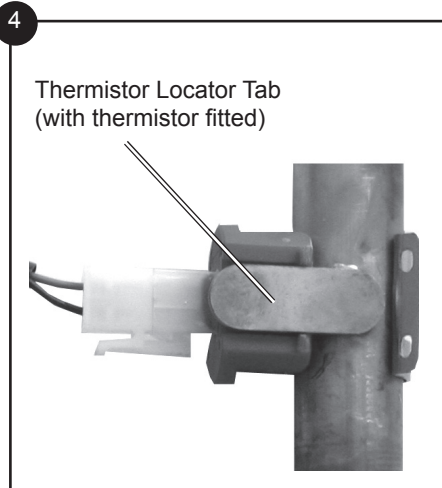

### 3.13 IGNITION ELECTRODE REPLACEMENT

1. Refer to Section 3.8.
2. Remove the burner. Refer to Section 3.11.
3. Unplug the ignition lead from the electrode.
4. Remove the earth lead from the ignition electrode.
5. Remove the 2 screws holding the ignition electrode to the combustion chamber.
6. Remove the electrode.
7. Fit the new ignition electrode, using the new gasket supplied. Check dimensions as shown.
8. Reassemble in reverse order.
9. Check the operation of the boiler. Refer to Sections 2.22 & 2.23.

Ignition Electrode

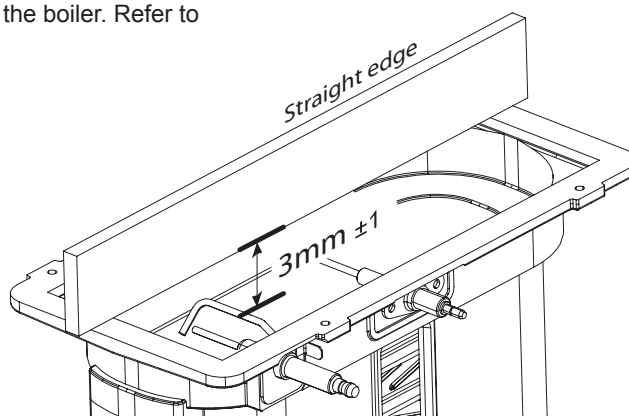
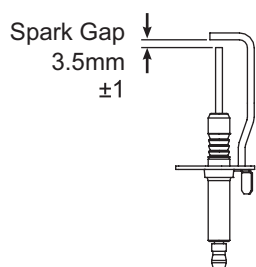
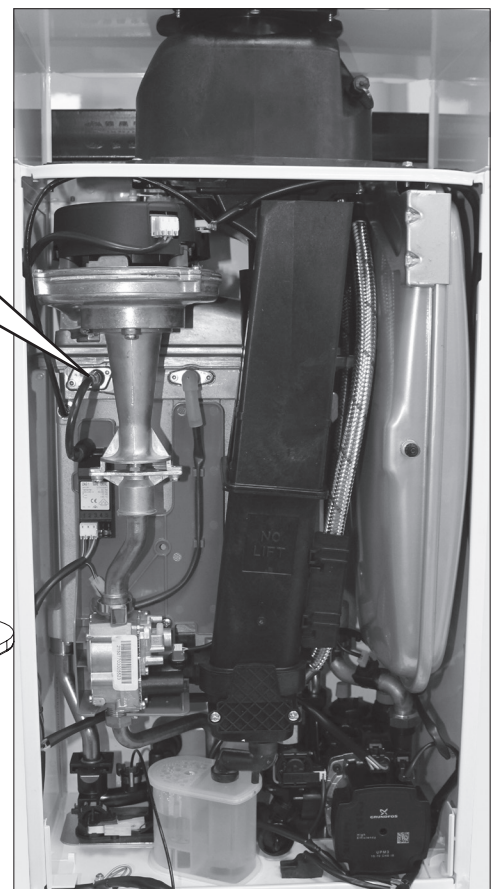
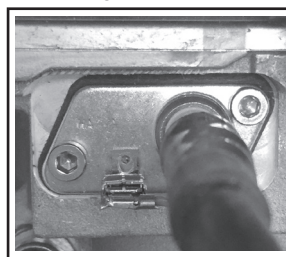

### 3.14 FLAME DETECTION ELECTRODE REPLACEMENT

1. Refer to Section 3.8
2. Remove the burner. Refer to Section 3.11.
3. Unplug the flame detection lead from the electrode.
4. Remove the 2 screws retaining the detection electrode.
5. Remove the electrode.
6. Fit the new flame detection electrode, using the new gasket supplied.
7. Reassemble in reverse order.
8. Check the operation of the boiler. Refer to Sections 2.22 & 2.23.

Flame Detection Electrode

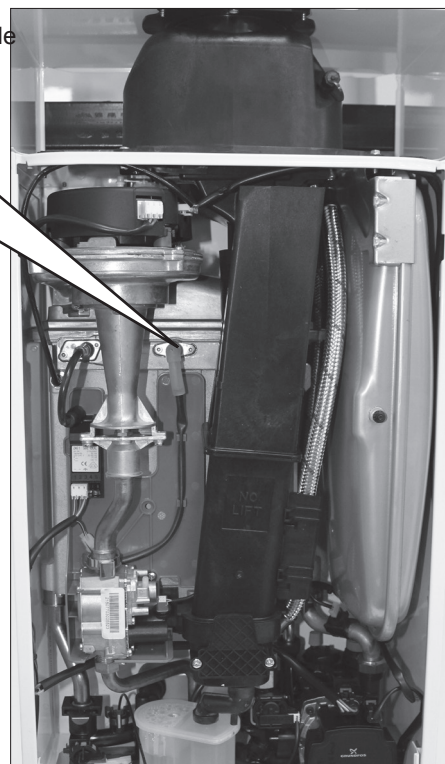
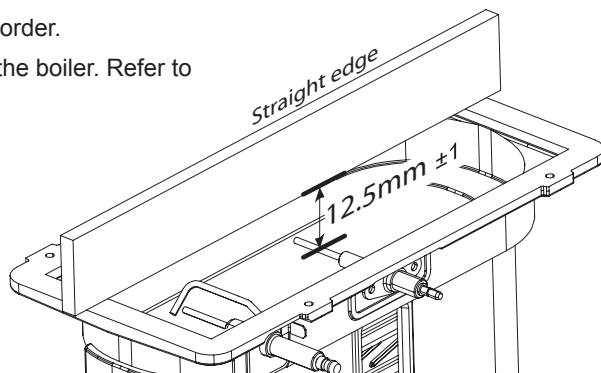
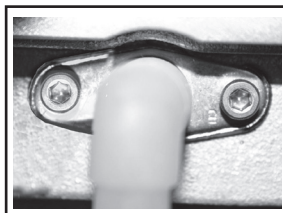

SERVICING

### 3.15 SPARK GENERATOR REPLACEMENT

1. Refer to Section 3.8.
2. Disconnect the leads from the spark generator.
3. Gently push down the generator to release the top clip from the gas valve mounting bracket.
4. Lift the spark generator up and out of the bottom retaining moulding.
5. Fit the new spark generator and re-assemble in reverse order ensuring that the the earth lead is replaced.
6. Check that the boiler operates in both DHW & CH modes.

Spark Generator

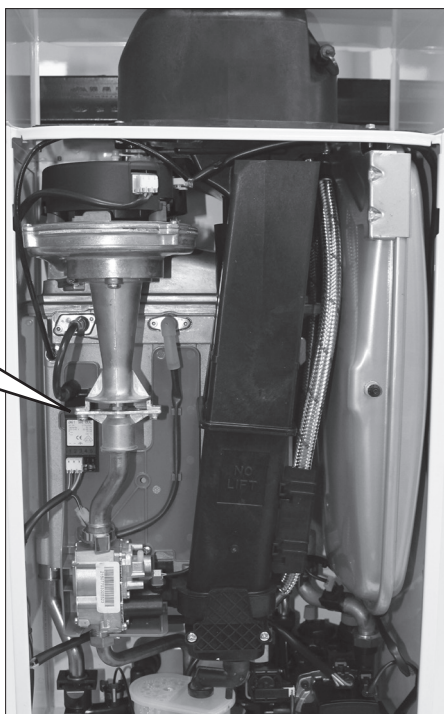

### 3.16 GAS CONTROL VALVE REPLACEMENT

1. Refer to Section 3.8.
2. Unplug the electrical lead connection from the gas control valve.
3. Remove the outlet gas valve clip and slide the pipe upwards.
4. Undo the gas inlet pipe union at the inlet to the gas valve.
5. Undo the single screw fixing the gas valve to the mounting bracket and withdraw the valve forwards.
6. Fit the new gas control valve ensuring that the O ring and sealing washer are in place and reconnect gas and electrical connections.
7. Ensure all gas valve connections are gas tight with a gas soundness check up to the gas control valve.
8. Check operation of the boiler. Refer to Sections 2.22 & 2.23.

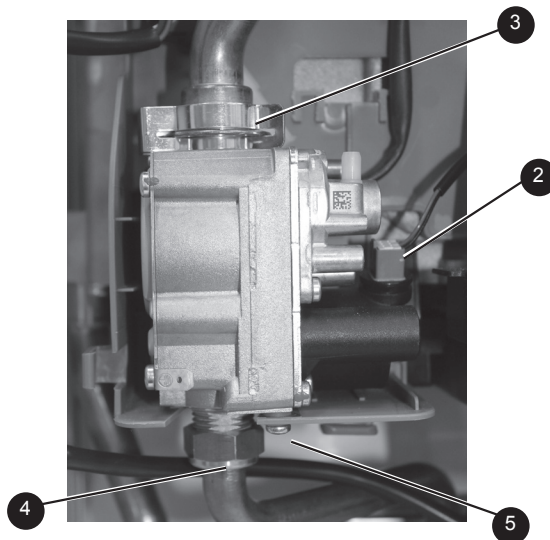

### 3.17 DIVERTER VALVE ACTUATOR REPLACEMENT

Refer to Section 3.8.

To remove the motor:

1. Remove the condensate trap/siphon. Refer to Section 3.18.
2. Place a flat bladed screwdriver in the actuator slot provided and ease out the actuator.
3. Before replacing the diverter valve actuator proceed as follows:
  - a. Ensure that the switched live to the boiler is off and that all DHW taps are shut and that pre-heat is switched off.
  - b. Press and hold the Function button and the "RESTART" buttons together for more than 5s, the last 3 faults will then be shown in sequence before "SL" is shown
  - c. Press the function button, "SH" will be shown
  - d. Press the function button, "UF" will be shown
  - e. Press the function button, "DU" will be shown
  - f. Press the function button and the diverter valve will move to the mid-position
4. Fit the new motor ensuring the arm is correctly engaged in the metal fork and re-assemble in reverse order ensuring the condensate trap/ siphon is refilled with water.
5. Check the operation of the boiler.

**Note.** All spares will be delivered in mid-position therefore ignore point 3 and proceed to point 4.

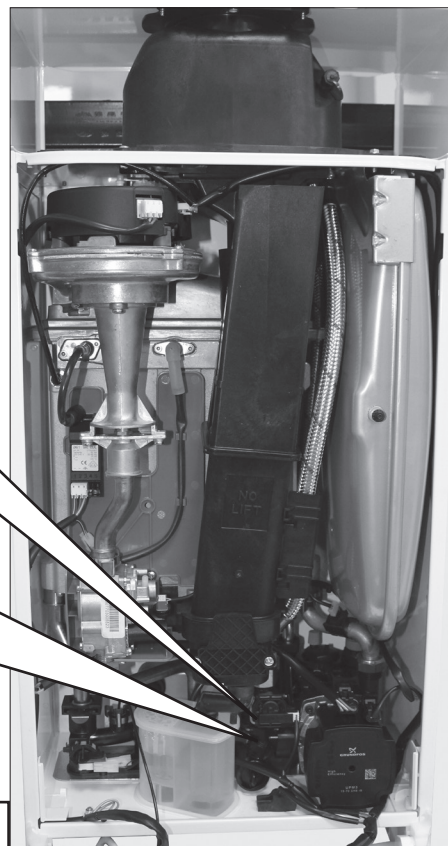
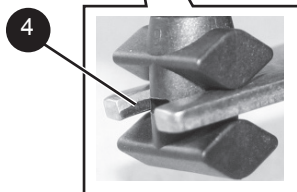
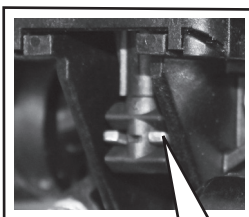
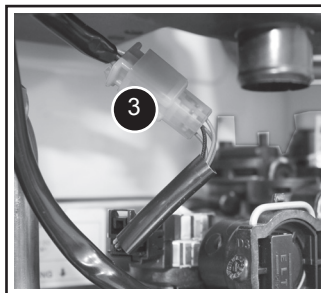

### 3.18 CONDENSATE TRAP/SIPHON REPLACEMENT

1. Refer to Section 3.8.

**Note:** Ensure condensate trap is fully drained before removal.

2. Pull off the rubber pipe at the sump drain.
3. Disconnect the condensate drain pipe.
4. Turn the siphon clockwise to disengage and lift to remove.

5. Reassemble in reverse order.

6. When reassembling ensure the trap is full of water.
7. Check operation of the boiler. Refer to Sections 2.22 & 2.23.

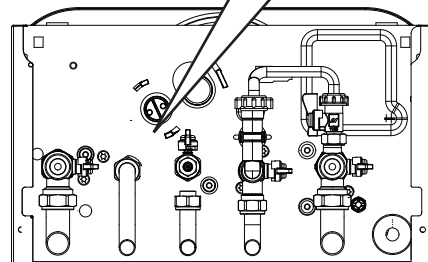
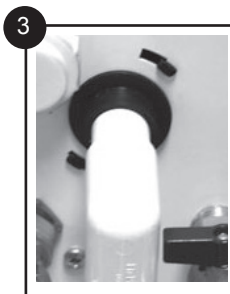
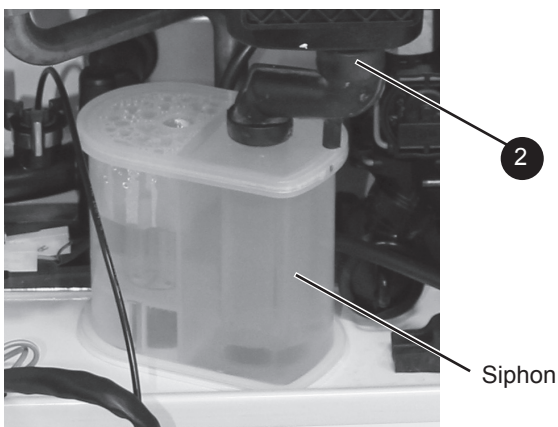

3.19 PCB REPLACEMENT

**Note.** Fit the earth strap provided with the PCB to your wrist and secure to a suitable earth on the boiler chassis.

1. Refer to Section 3.8.
2. Ensure the control knobs are in the 12 o'clock position.
3. Carefully release the six retaining clips and remove control box cover.
4. Unplug all lead connections to the PCB.
5. Remove the 2 screws, if applicable.
6. Spring out the four side retaining clips and pull the PCB upwards to clear the corner retaining posts.
7. Take the new PCB.
8. Re-connect all plug connections.
9. Reassemble in reverse order.
10. a. Turn power on, display shows uP. Rotate all three dials fully anti-clockwise.  
 b. Press RESTART, display shows oF  
 c. Turn power off  
 d. Turn power on, display shows F9  
 e. Using central heating knob, rotate clockwise or anticlockwise to show "C" for Combi, then press RESTART button.  
 f. Using central heating knob, rotate clockwise or anticlockwise to show "n" for Natural Gas, then press restart button.  
 g. Using central heating knob rotate clockwise or anticlockwise to show boiler size, select correct 26, 33 or 38, then press RESTART button.  
 h. Display shows "C", "n", Boiler size, internal number.  
 j. Press restart. New PCB is now programmed.
11. Check that the boiler operates in both DHW and CH modes.

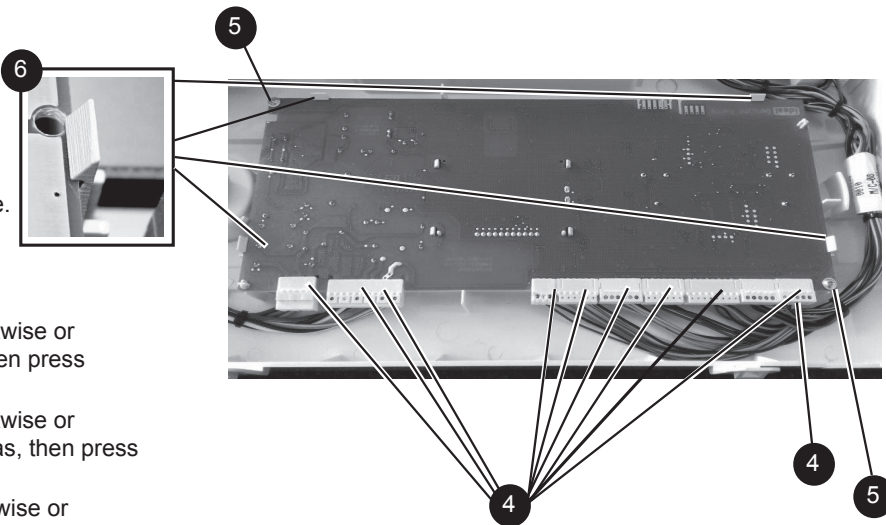
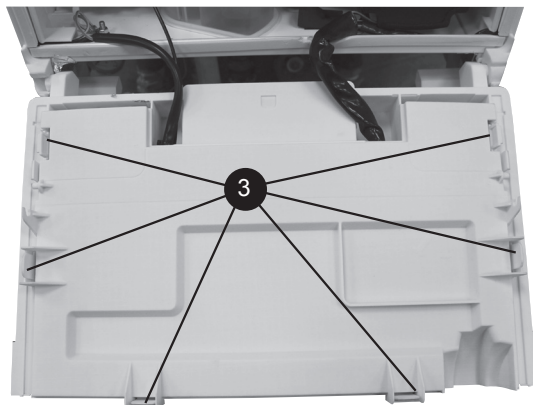

**IMPORTANT.** IT IS CRITICAL FOR SAFE OPERATION THAT THE CORRECT BOILER SIZE AND FUEL TYPE IS ENTERED INTO THE BOILER.

SERVICING

3.20 DHW FLOW TURBINE SENSOR REPLACEMENT

1. Refer to Section 3.8.
2. Drain the DHW system. Refer to Section 3.21.
3. Pull off the electrical connection.
4. Using a suitable tool, lift and remove the retaining clip.
5. Use the clip to ease the turbine sensor from its housing.
6. Re-assemble in reverse order.
7. Check operation of the boiler. Refer to Sections 2.22 & 2.23.

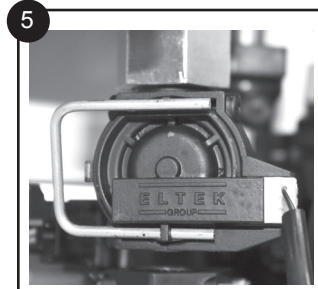
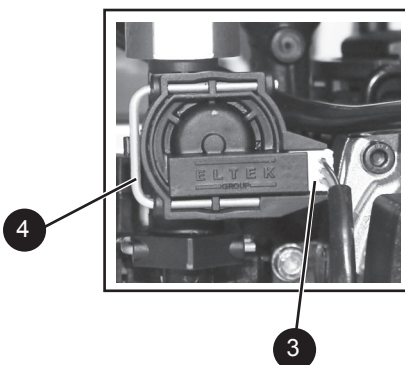

### 3.21 DRAINING THE BOILER

#### CENTRAL HEATING CIRCUIT

1. Refer to Section 3.8.
2. Close all the CH water isolating valves on the boiler inlet.
3. To drain the primary heat exchanger circuit: Open the drain valve and attach a length of hose to the CH drain point.
4. After replacing any component on the boiler, remove the hose, close the drain valve and open all system isolating valves (re-pressurise as appropriate by re-connecting the filling loop, refer to Section 2.15) before proceeding to check operation of the boiler.
5. Disconnect filling loop. Refer to Section 2.15.
6. Check operation of the boiler. Refer to Sections 2.22 & 2.23.

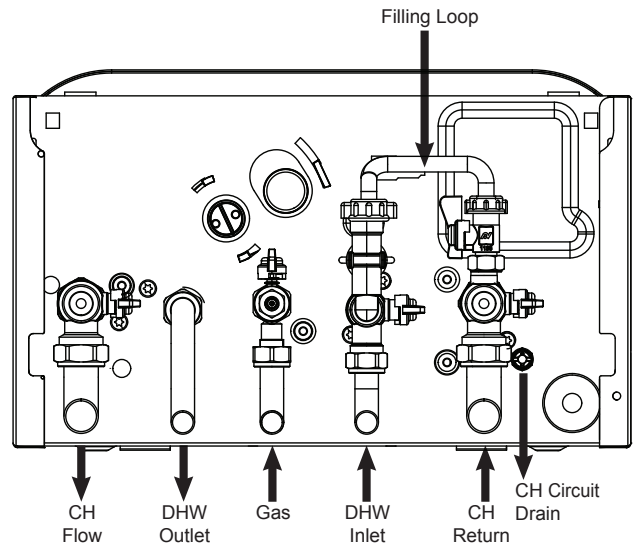

#### DOMESTIC HOT WATER CIRCUIT

1. Refer to Section 3.8.
2. Close all the DHW water isolating valves on the boiler inlet.
3. To drain the DHW circuit: As there is no direct drain for the DHW circuit, depending on the location of the boiler, opening the lowest hot water tap may drain this circuit. However it must be noted that some residual water will be experienced during replacement of components.
4. After replacing any component on the boiler, close tap, open the DHW isolation valve and open all system isolating valves (re-pressurise as appropriate by re-connecting the filling loop, refer to Section 2.15) before proceeding to check operation of the boiler.
5. Disconnect filling loop. Refer to Section 2.15.
6. Check operation of the boiler. Refer to Sections 2.22 & 2.23.

### 3.22 PRESSURE GAUGE REPLACEMENT

1. Refer to Section 3.8.
2. Drain the heating system. Refer to Section 3.21.
3. Remove the boiler front (See Sections 3.2 & 3.19), lower the control panel and remove the control box cover.
4. Ensuring there is no pressure in the system unclip the C clip from the flow manifold port and remove the capillary connection together with 'o' ring.
5. Releasing the two retaining clips on the pressure gauge ease the pressure gauge through the front of the control panel.
6. Fit the new pressure gauge from the front of the control panel ensuring correct orientation. Locate push fit connection into port ensuring 'o' ring in place and secure with the C clip.
7. Refill the boiler. Refer to Section 2.15.
8. Check that the boiler operates in both DHW & CH modes.

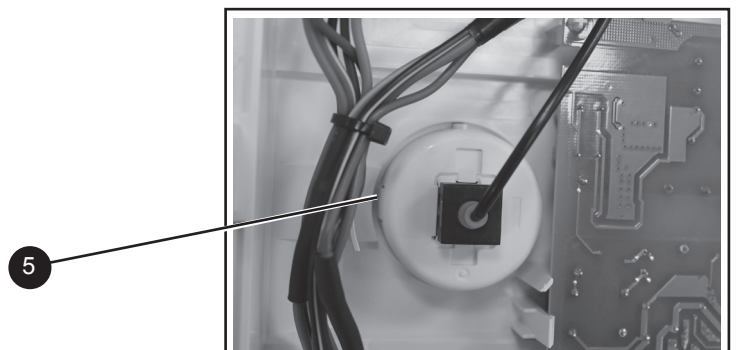
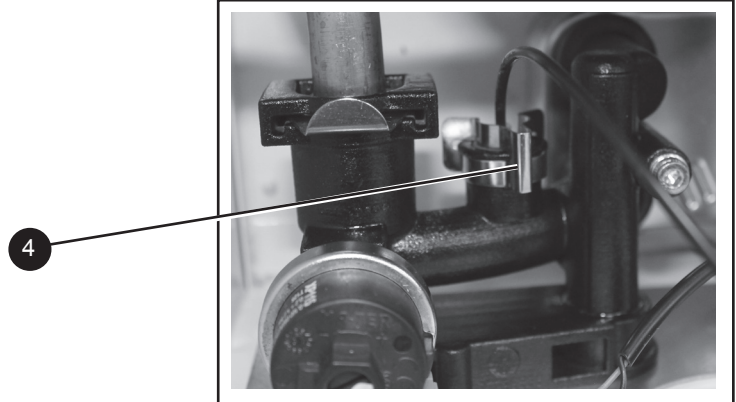

### 3.23 SAFETY RELIEF VALVE RENEWAL

1. Refer to Section 3.8.
2. Drain the boiler. Refer to Section 3.21.
3. Remove the clip on return thermistor. Refer to Section 3.12.
4. Pull out and remove the clip (positioned behind the safety valve) retaining the safety valve.
5. Undo the safety valve pipe compression fitting positioned outside the boiler casing.
6. Lift out the safety valve/pipe assembly.
7. Remove the safety valve pipe and transfer to the new safety valve.
8. Reassemble in reverse order ensuring the retaining clip is correctly fitted, the pipe compression fitting retightened and return thermistor is re-clipped.
9. Refill the boiler. Check operation of the boiler. Refer to Sections 2.22 & 2.23.

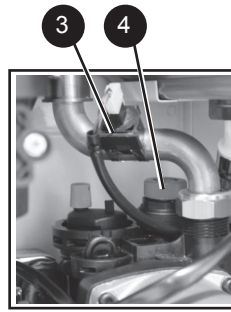

### 3.24 PUMP AUTOMATIC AIR VENT REPLACEMENT

1. Refer to Section 3.8.
2. Drain the boiler. Refer to Section 3.21.
3. Remove the expansion vessel. Refer to Section 3.32.
4. Firstly, increase access area by disconnecting the 22mm pipe connection at top of pump chamber and bottom of heat exchanger and remove pipe.
5. The automatic air vent head is retained in the pump body with a bayonet connection. The air vent head and float assembly is removed by turning the head anti-clockwise (viewed from above) and pulling upwards.
6. Reassembly is the reverse of the above. Ensure the air vent head 'o' ring seal is in place when refitting and the new 'o' ring is fitted to the return pipe top connection.
7. Make sure that the Automatic Air Vent is set at fully OPEN.
8. Refill the boiler. Refer to Section 2.15. Check for leaks around the new air vent joint.
9. Check the operation of the boiler. Refer to Sections 2.22 & 2.23.

Dust Cap

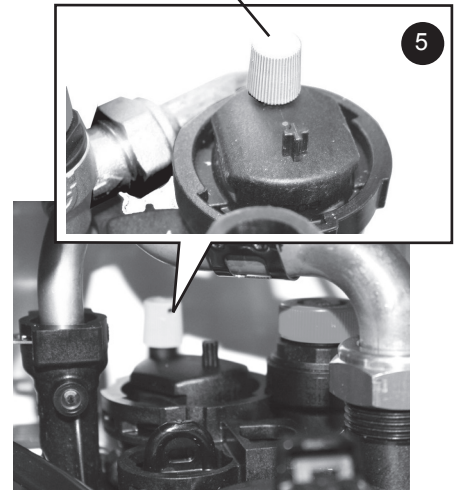

### 3.25 DHW FILTER & DHW FLOW REGULATOR CLEANING/REPLACEMENT

1. Refer to Section 3.8.
2. Drain the DHW system. Refer to Section 3.21.
3. Turn the housing anti clockwise and pull forward to remove the cartridge.
4. Using a pair of pliers, pull out the plastic filter/flow regulator.
5. Clean or replace filter as necessary.
6. Reassemble in reverse order.
7. Refill the boiler.
8. Check operation of the boiler. Refer to Sections 2.22 & 2.23.

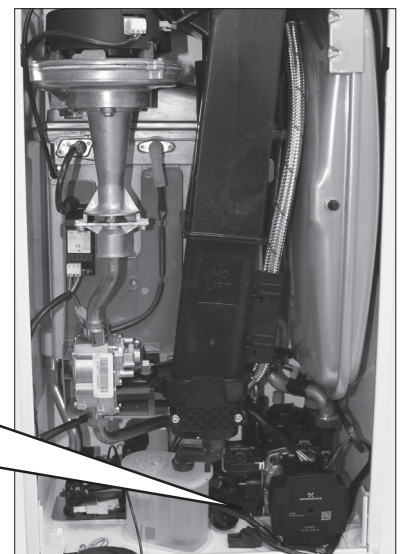
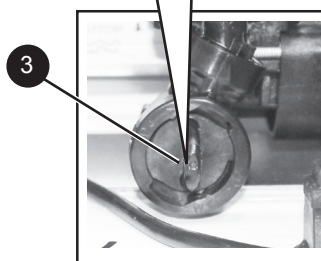
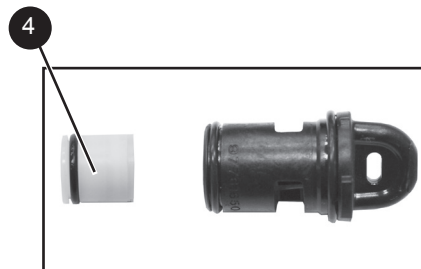

### 3.26 DIVERTER VALVE BODY ASSEMBLY REPLACEMENT

To remove the valve body assembly:

1. Refer to Section 3.8.
2. Drain the boiler. Refer to Section 3.21.
3. Remove the condensate trap/siphon. Refer to Section 3.18.
4. Remove the electrical plug. Refer to Section 3.17.
5. Place a flat bladed screwdriver in the diverter valve motor body slot provided and ease out the motor. Refer to Section 3.17.
6. Remove the return thermistor electrical connection. Refer to Section 3.12.
7. Remove the pump electrical connections. Refer to Section 3.28 no. 3.
8. Remove DHW Turbine electrical connection. Refer to Section 3.20 no. 3.
9. Remove the DHW plate heat exchanger (note orientation). Refer to Section 3.27.
10. Undo the safety valve pipe compression fitting. See No.5 Section 3.23.
11. Loosen the nut above pump and rotate the pipe.
12. If required remove expansion vessel connection hose. Refer to Section 3.32.
13. Remove the DHW inlet and CH return connection situated beneath the boiler.
14. Remove the four torx head screws fixing the return manifold to the boiler sheet steel base.
15. Lift the manifold assembly and remove from boiler.

16. Twist and remove the DHW manifold.
17. Remove the two diverter valve body fixing screws and withdraw the diverter valve body assembly.
18. Fit the new diverter valve body assemble and replace the two fixing screws.
19. Refit the DHW manifold, fit the assembly back to the boiler and reassemble in reverse order.
20. Refill the boiler refer to Section 2.15. Check operation of the boiler. Refer to Sections 2.22 & 2.23.

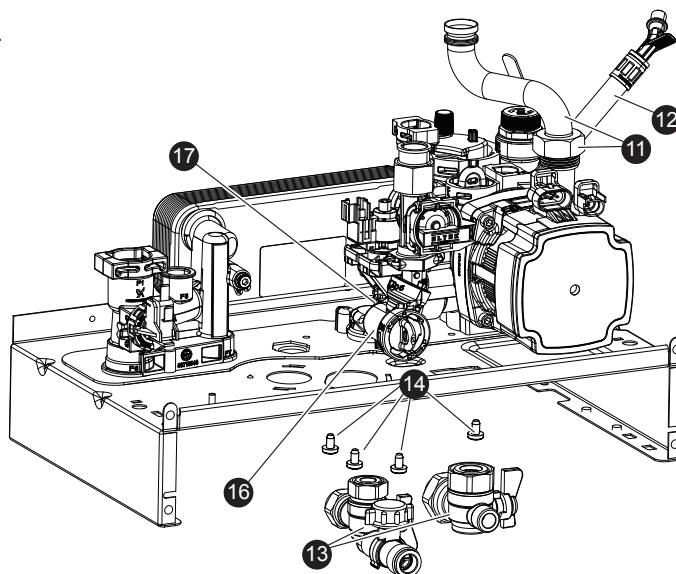

### 3.27 DHW PLATE HEAT EXCH. REPLACEMENT

1. Refer to Section 3.8.
  2. Drain the boiler. Refer to Section 3.21.
  3. Remove condensate trap/siphon. Refer to Section 3.18.
  4. Remove the diverter valve actuator. Refer to Section 3.17.
  5. Remove the 2 allen screws securing the plate heat exchanger to the composite housings.
  6. Manoeuvre the plate heat exchanger out of the top LH or centre of the controls area. Be aware of any water spillage.
  7. Fit the new plate heat exchanger, using the new o-rings supplied.
- Note.** Ensure that the depressions are on the bottom prior to fitting.
8. Reassemble in reverse order.
  9. Refill the boiler. Refer to Section 2.15.
  10. Check operation of the boiler. Refer to Sections 2.22 & 2.23

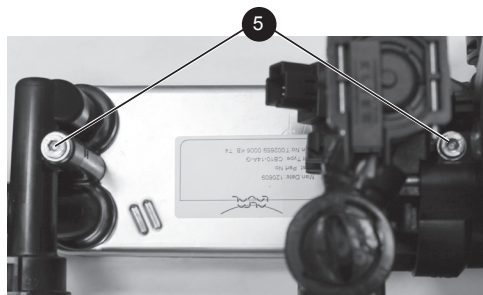

### 3.28 PUMP HEAD REPLACEMENT

1. Refer to Section 3.8.
2. Drain the boiler. Refer to Section 3.21.
3. Disconnect the 2 electrical leads from the pump.
4. Remove the 4 Allen screws retaining the pump head.
5. Remove the pump head.
6. Fit the new pump head.
7. Reassemble in reverse order.
8. Refill the boiler. Refer to Section 2.15.
9. Check operation of the boiler. Refer to Sections 2.22 & 2.23.

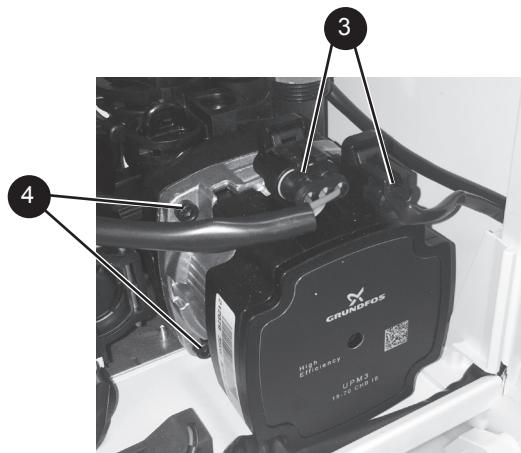

### 3.29 CH WATER PRESSURE SWITCH REPLACEMENT

1. Refer to Section 3.8.
2. Drain the boiler. Refer to Section 3.21.
3. Pull off the two electrical connections.
4. Using a suitable tool, pull out the metal retaining clip.
5. Carefully withdraw the pressure switch.
6. Fit the new pressure switch and re-assemble in reverse order.
7. Refill the boiler.
8. Check operation of the boiler. Refer to Sections 2.22 & 2.23.

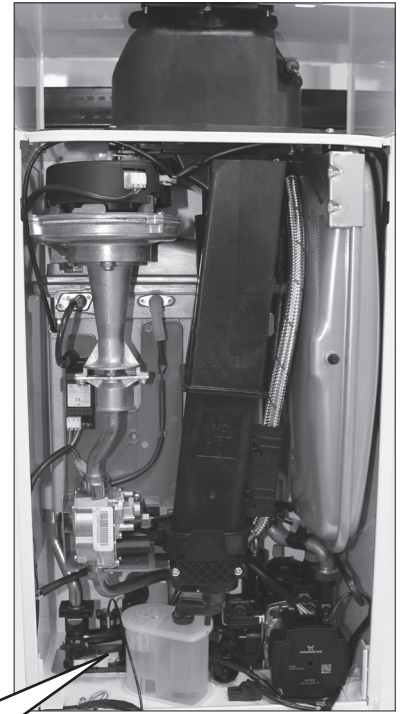
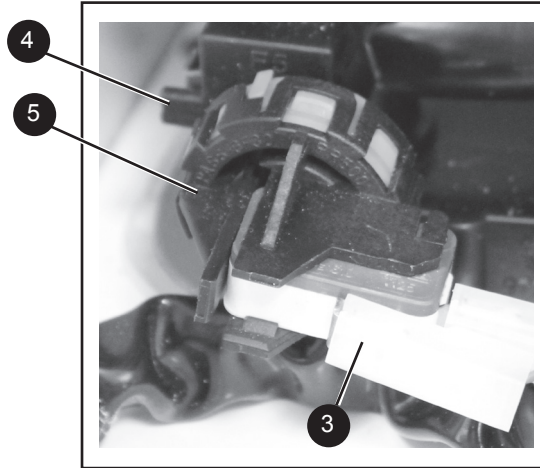

### 3.30 FLOW THERMISTOR REPLACEMENT

1. Refer to Section 3.8.
2. Drain down the boiler. Refer to Section 3.21.
3. Unplug the electrical lead.
4. Unscrew the thermistor (to facilitate removal a 13mm socket spanner should be used).
5. Fit the new thermistor using the sealing washer provided.
6. Reassemble in reverse order.
7. Refill the boiler. Refer to Section 2.15.
8. Check the operation of the boiler. Refer to Sections 2.22 & 2.23.

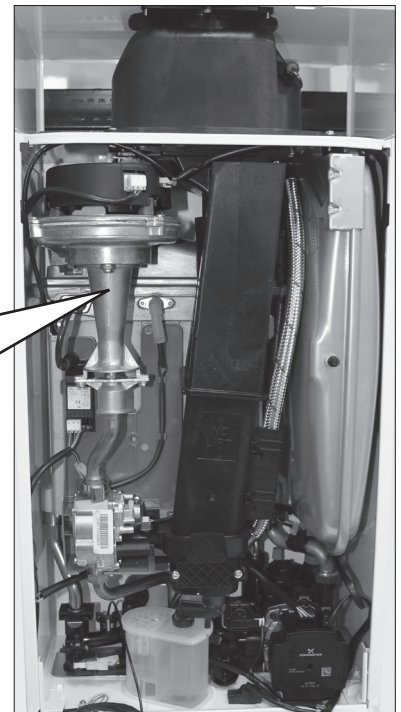
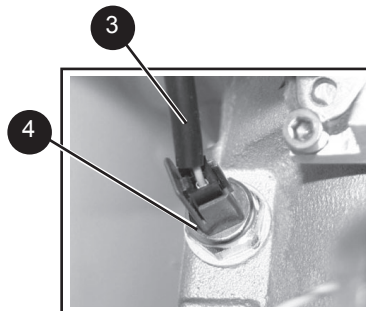

### 3.31 HEAT ENGINE RENEWAL

Refer also to Section 2.1 - 'Boiler Exploded View'

#### IMPORTANT

Before starting the removal procedure, protect the gas and electrical controls with a waterproof sheet or plastic bag.

1. Refer to Section 3.8.
2. Drain the boiler. Refer to Section 3.21.
3. Remove the fan / venturi assembly and place on one side. Disconnect recuperator pipes. Refer to Section 3.33.
4. Remove the burner and place on one side. Refer to Section 3.4.
5. Remove the ignition and detection electrodes. Refer to Section 3.13 & 3.14.
6. Remove the spark generator. Refer to Section 3.15.
7. Remove the gas valve. Refer to Section 3.16.
8. Remove the expansion vessel. Refer to Section 3.32.
9. Remove the flow and return thermistor. Refer to Sections 3.30 & 3.12.
10. Remove the 2 M5 screws retaining the gas valve mounting bracket and transfer bracket to the new heat exchanger.
11. Undo the pump union nut and remove pipe.
12. Remove the two retaining spring clips and remove pipes.
13. Remove the condensate rubber pipe. Refer to Section 3.18, no. 2.
14. Remove the two heat exchanger fixing screws.
15. Remove the Heat exchanger, slide out of location bracket.
16. If replacement sump required: Rotate heat exchanger assembly 180°. Place new sump onto heat exchanger, ensuring correct orientation and seal is in place. Then gently apply pressure to the base of the sump at each tab fixing point and engage tabs onto the heat exchanger.
17. Reassemble in reverse order ensuring the heat exchanger is correctly positioned in the LH retaining bracket. Replace any new 'o' rings supplied with new heat exchanger and replacing gaskets or seals if any sign of damage is evident. When replacing the spring clips located on the return pipe connection, ensure clip is orientated to correctly match connecting pipe diameters.
18. Ensure the trap/siphon is filled with water. Refer to Sections 3.18.
19. Refill the boiler. Refer to Section 2.15.
20. Ensure all gas valve connections are gas tight with a gas soundness check up to the gas control valve.
21. Check operation of the boiler. Refer to Sections 2.22 & 2.23.

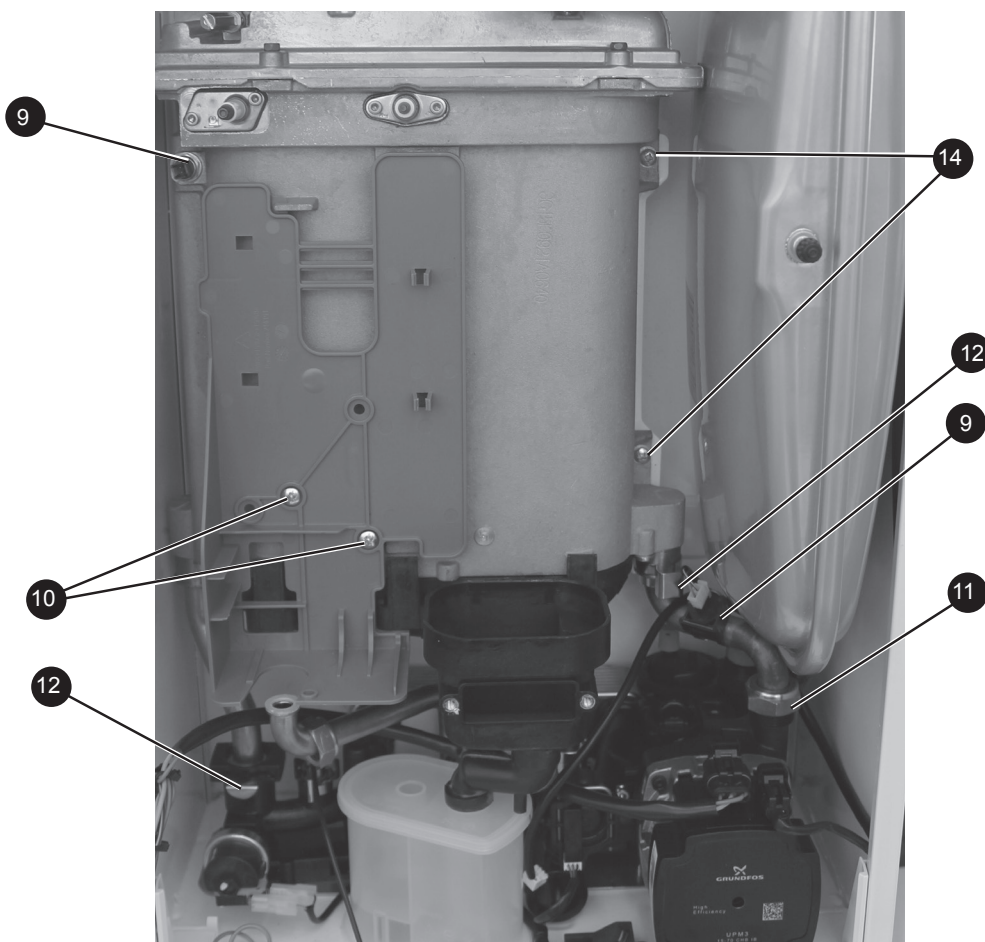

Shown as 180° position

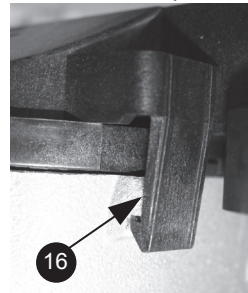

### 3.32 EXPANSION VESSEL RECHARGING & REPLACEMENT

#### RECHARGING

1. Refer to Section 3.8.
2. Remove the charge point cover.
3. Recharge the tank pressure to 0.75 bar.
4. Re-assemble in reverse order
5. Check operation of the boiler. Refer to Sections 2.22 & 2.23.

#### REPLACEMENT

6. Refer to Section 3.3.8.
7. Drain the boiler CH circuit. Refer to Section 3.21.
8. Remove the retaining clip on the vessel water connection pipe.
9. Support the expansion vessel and unscrew the 2 screws from the securing clamp, located on the top of the boiler, and remove. (Note the position of the bracket on the vessel)
10. Remove the expansion vessel.
11. Fit the new expansion vessel.
12. Reassemble in reverse order ensuring the seal is in place.
13. Refill the boiler. Refer to Section 2.15.
14. Check operation of the boiler. Refer to Sections 2.22 & 2.23.

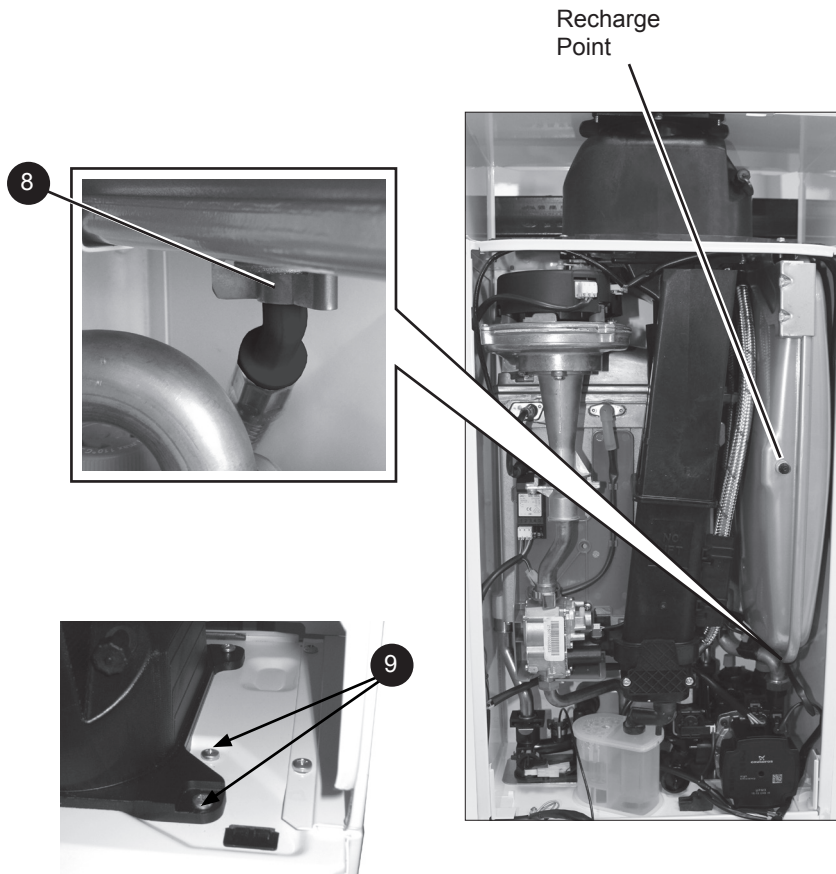

### 3.33 RECUPERATOR REPLACEMENT & CLEANING

1. Refer to Section 3.8.
2. Drain the DHW circuit, refer to Section 3.21.
3. Undo the two screws and remove the sump cover retaining the lower flue manifold.
4. Lift the manifold to clear the bottom sealing gasket and remove manifold.
5. Remove the fan. Refer to Section 3.9.
6. Remove the burner. Refer to Section 3.4.
7. Disconnect the flue sampling tube.
8. Undo the 4 screws retaining the recuperator assembly to the underside on the boiler top panel.
9. Remove the recuperator from the flue connection by pulling downwards.
10. Remove the C clips from the recuperator pipes and disconnect.
11. Fit the new recuperator assembly replacing all flue seals and O rings with those provided. Ensure both flue seals are correctly in place before re-assembly.
12. Reconnect the DHW pipes to the recuperator ensuring both pipes are fitted into the correct connection - blue to the bottom and red to the top.
13. Re-fit the recuperator taking care not to trap the flue sampling tube.
14. Reassemble the boiler in reverse order.
15. Refill the boiler. Refer to Section 2.15.
16. Check the operation of the boiler. Refer to Sections 2.22 & 2.23.

#### CLEANING

Thoroughly flush the recuperator by pouring water into the flue inlet or outlet ensuring the full area is covered.

Re-assemble the boiler in reverse order as above.

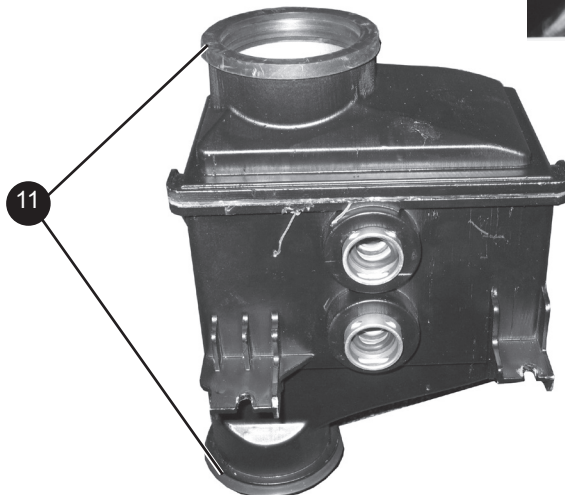
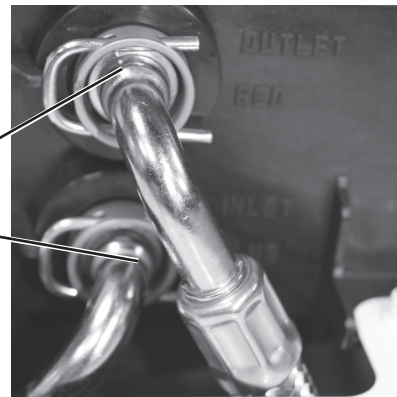
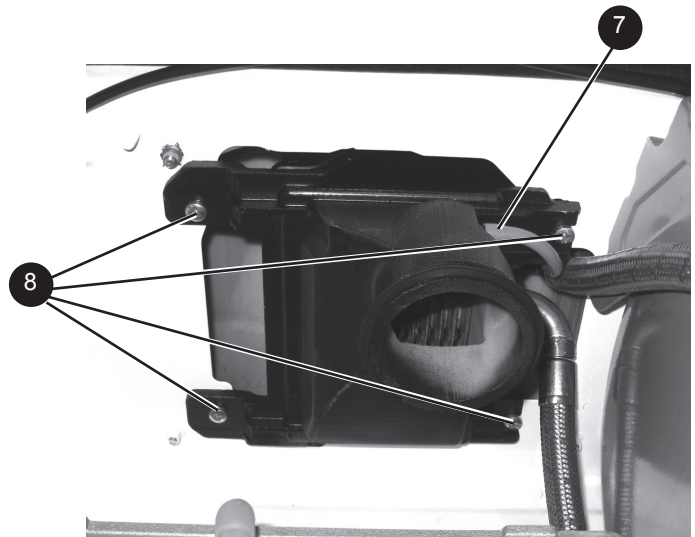

## SECTION 4 - FAULT FINDING

### 4.1 FAULT FINDING CHART MAIN MENU

'L1'	GO TO SECTION 4.2 - FLOW TEMPERATURE OVERHEAT LOCKOUT
'L2'	GO TO SECTION 4.3 - IGNITION LOCKOUT
'LC'	5 RESETS WITHIN 15 MINS - TURN POWER OFF AND ON
'L6'	GO TO SECTION 4.4 - FALSE FLAME LOCKOUT
'F1'	GO TO SECTION 4.5 - LOW WATER PRESSURE
'F2 or Fn or Ln'	GO TO SECTION 4.6 - FLAME LOSS
'F3'	GO TO SECTION 4.7 - FAN FAULT
'L4 or F4'	GO TO SECTION 4.8 - FLOW THERMISTOR FAULT
'L5 or F5'	GO TO SECTION 4.9 RETURN THERMISTOR FAULT
'F6'	GO TO SECTION 4.10 OUTSIDE SENSOR FAULT
'F7'	LOW MAINS VOLTAGE - CONTACT ELECTRICITY PROVIDER
'F9 or L9 or F8 or L8'	PCB UNCONFIGURED OR FAULTY SEE SECTION 3.19 IF FAULT PERSISTS REPLACE PCB
'FA'	NEGATIVE DIFFERENTIAL FLOW OR RETURN THERMISTOR FAULT
'FU'	DIFF GREATER THAN 50°C CHECK ISOLATION VALVES ARE OPEN CHECK PUMP CHECK RAD VALVES OPEN CHECK SYSTEM BLOCKAGES
'dU'	DIVERTER VALVE IN MID-POSITION FOR SERVICE ROTATE KNOBS FULLY CLOCKWISE TURN POWER OFF AND ON RESTART BOILER
NO CH BUT HW OK	GO TO SECTION 4.11
NO HW BUT CH OK	GO TO SECTION 4.12
NO DISPLAY	GO TO SECTION 4.13

RESTART PROCEDURE: to restart boiler press the restart button.

## SECTION 4 - FAULT FINDING

### 4.2 'L1' - FLOW TEMPERATURE OVERHEAT LOCKOUT

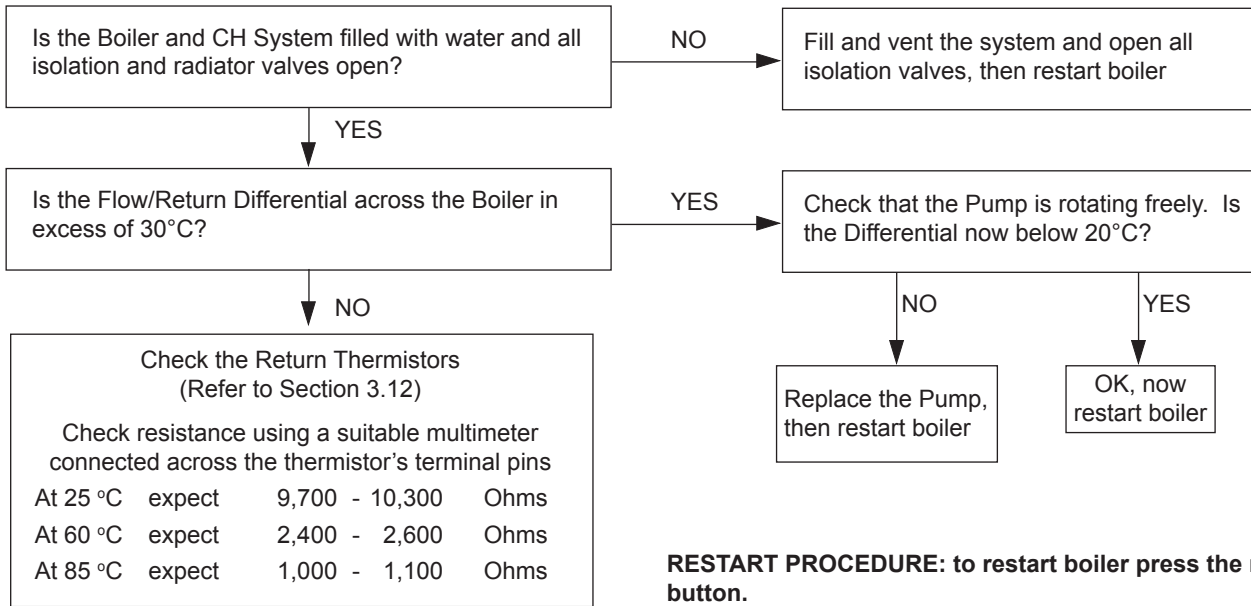

### 4.3 'L2' - IGNITION LOCKOUT

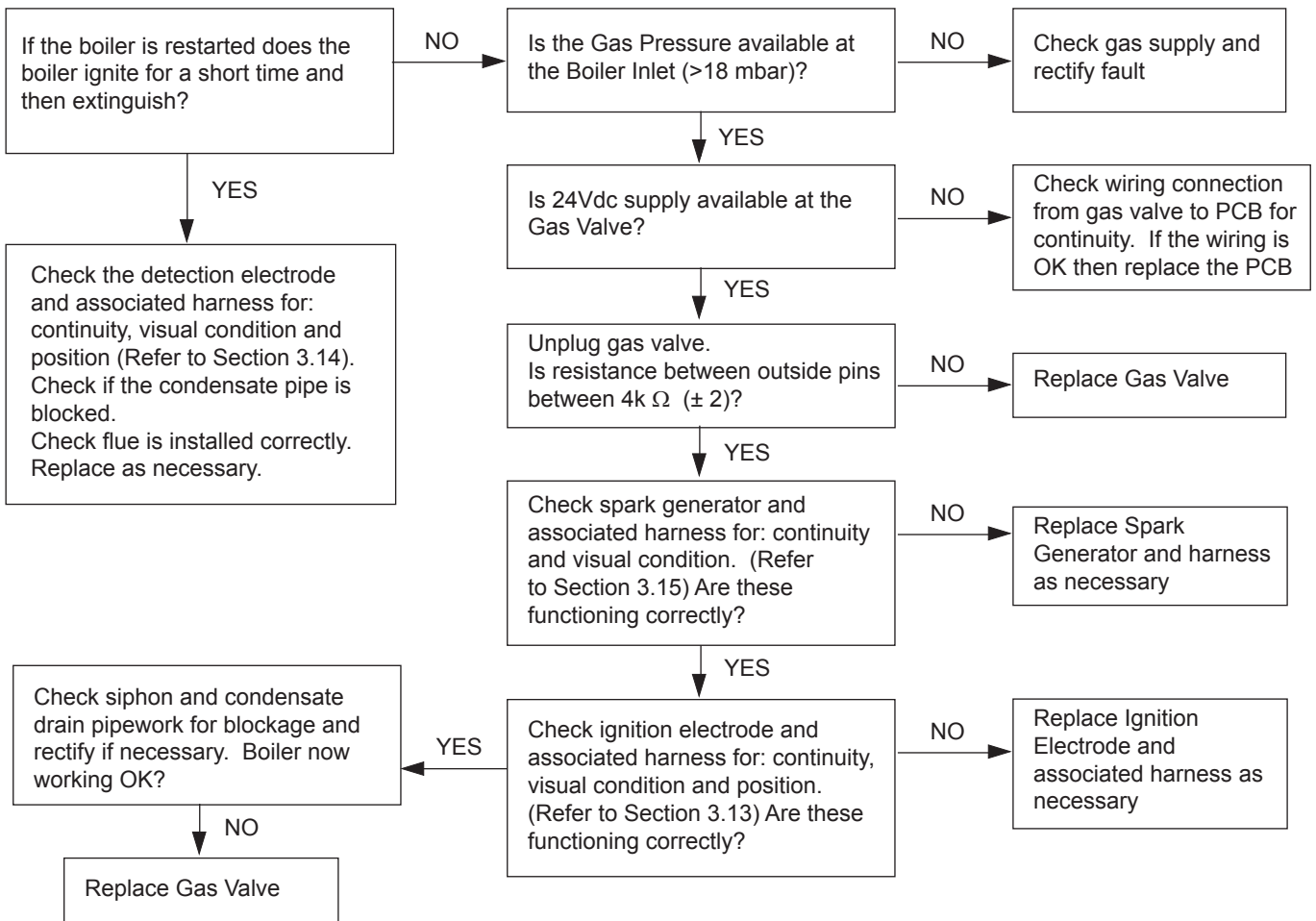

## SECTION 4 - FAULT FINDING

### 4.4 'L6' - FALSE FLAME LOCKOUT

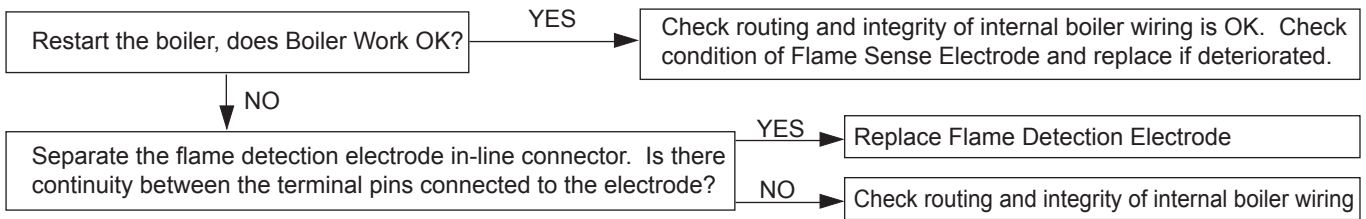

**RESTART PROCEDURE** - To restart boiler, press and release RH push button.

### 4.5 'F1' - LOW WATER PRESSURE

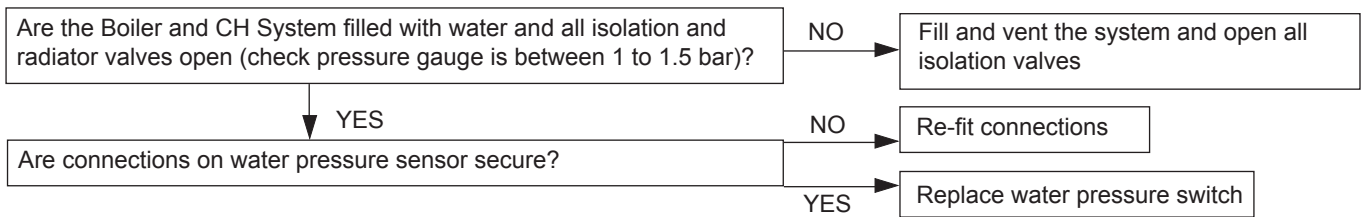

### 4.6 'F2 OR FN OR LN' - FLAME LOSS

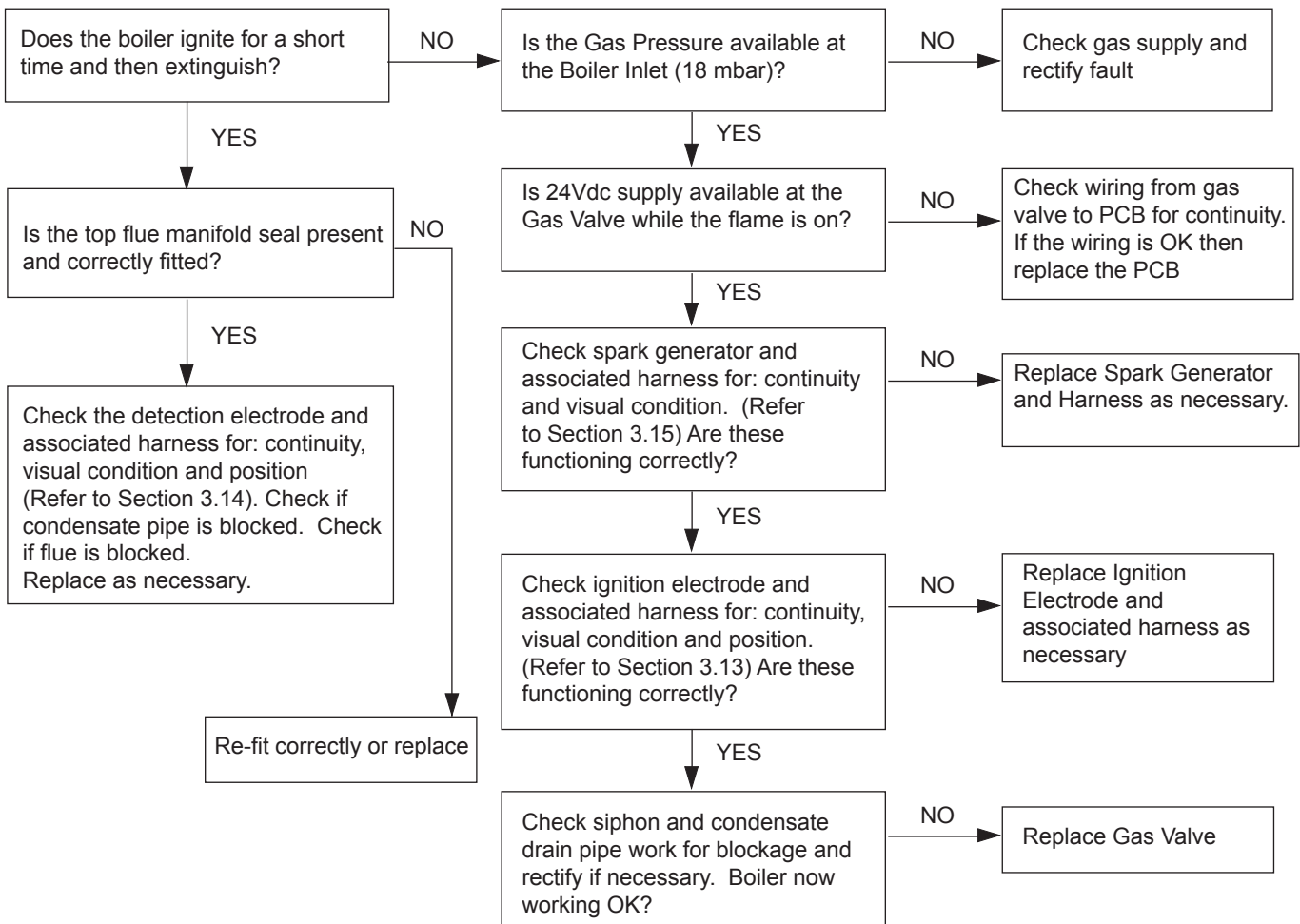

## SECTION 4 - FAULT FINDING

### 4.7 'F3' - FAN FAULT

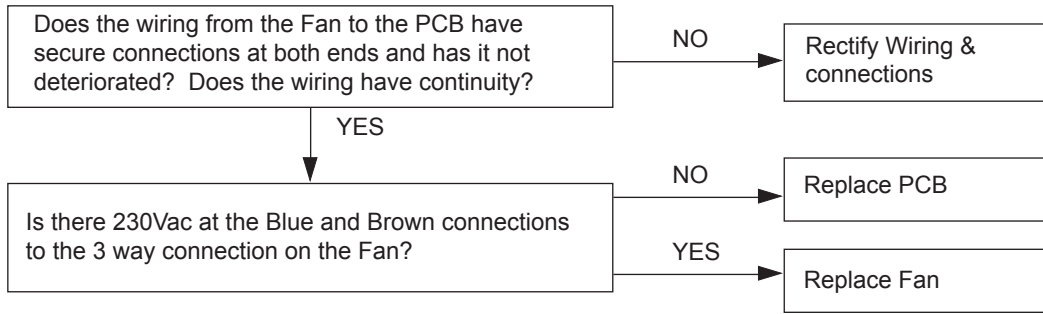

### 4.8 'F4 OR L4' - FLOW THERMISTOR FAULT

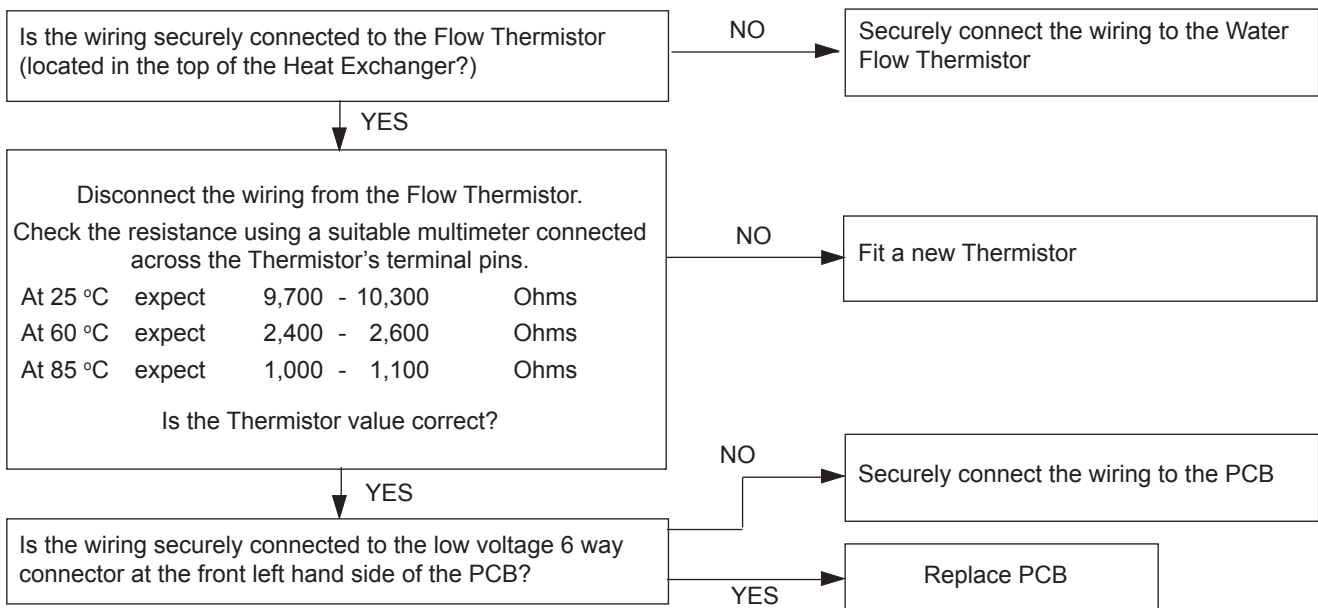

### 4.9 'F5 OR L5' - RETURN THERMISTOR FAULT

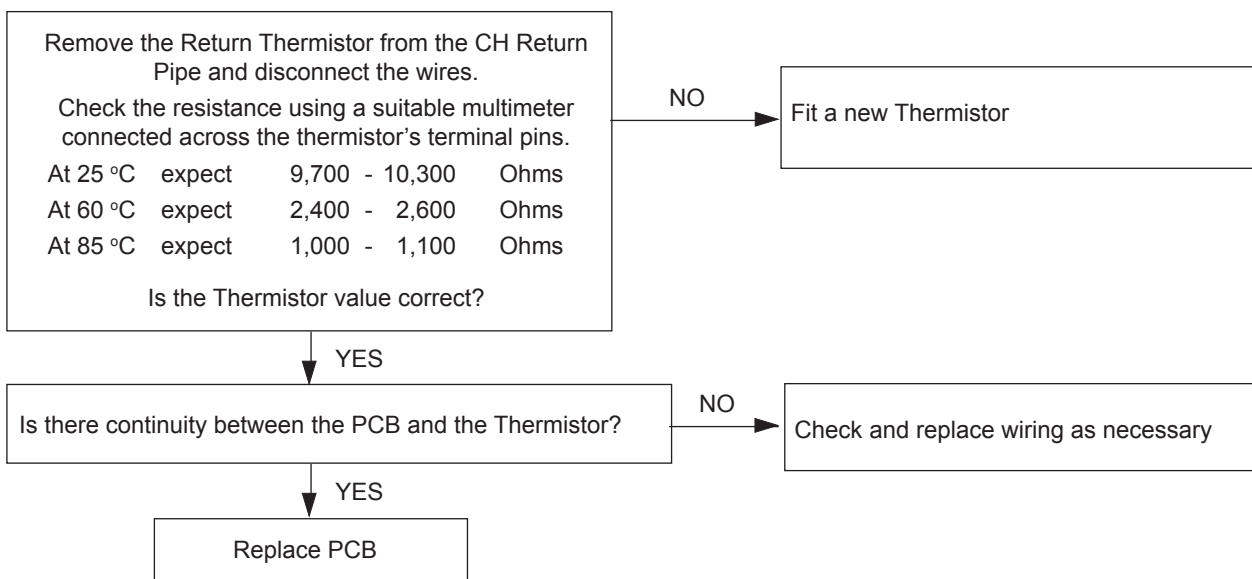

## SECTION 4 - FAULT FINDING

### 4.10 'F6' - OUTSIDE SENSOR FAULT

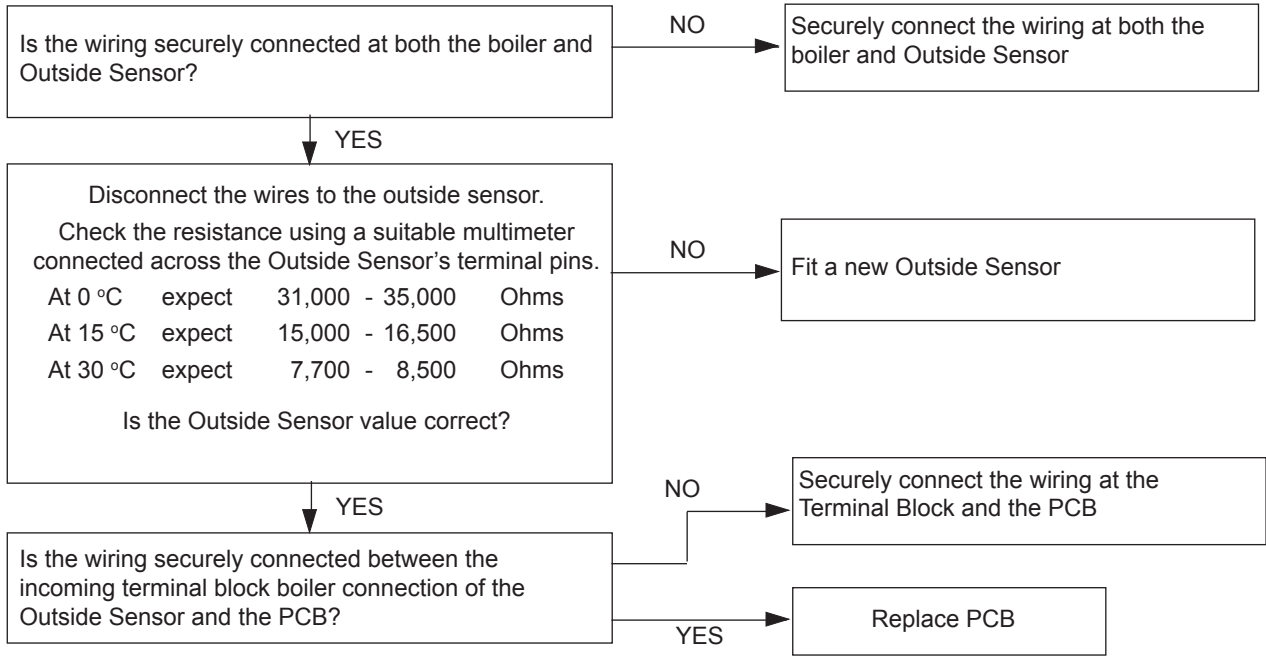

### 4.11 NO CH OPERATION BUT HW WORKS OK

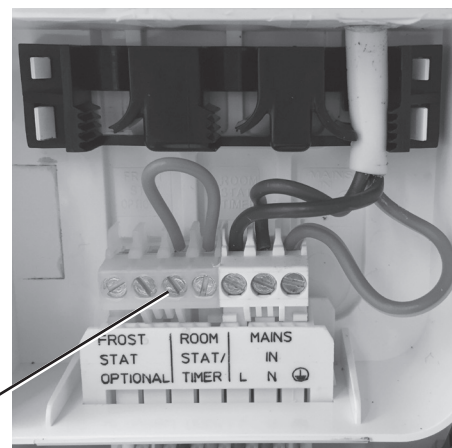
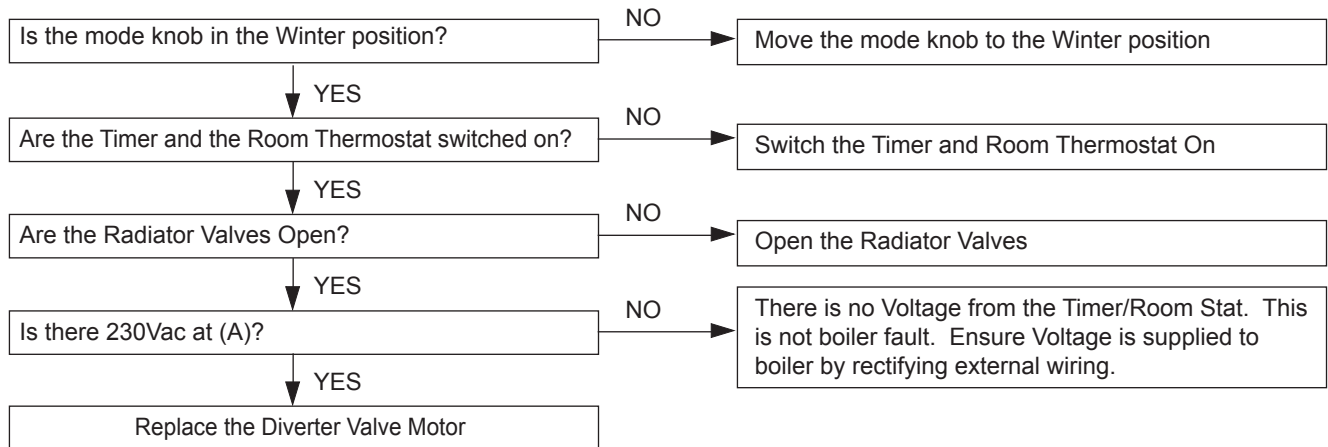

A

## SECTION 4 - FAULT FINDING

### 4.12 NO HW BUT CH ON

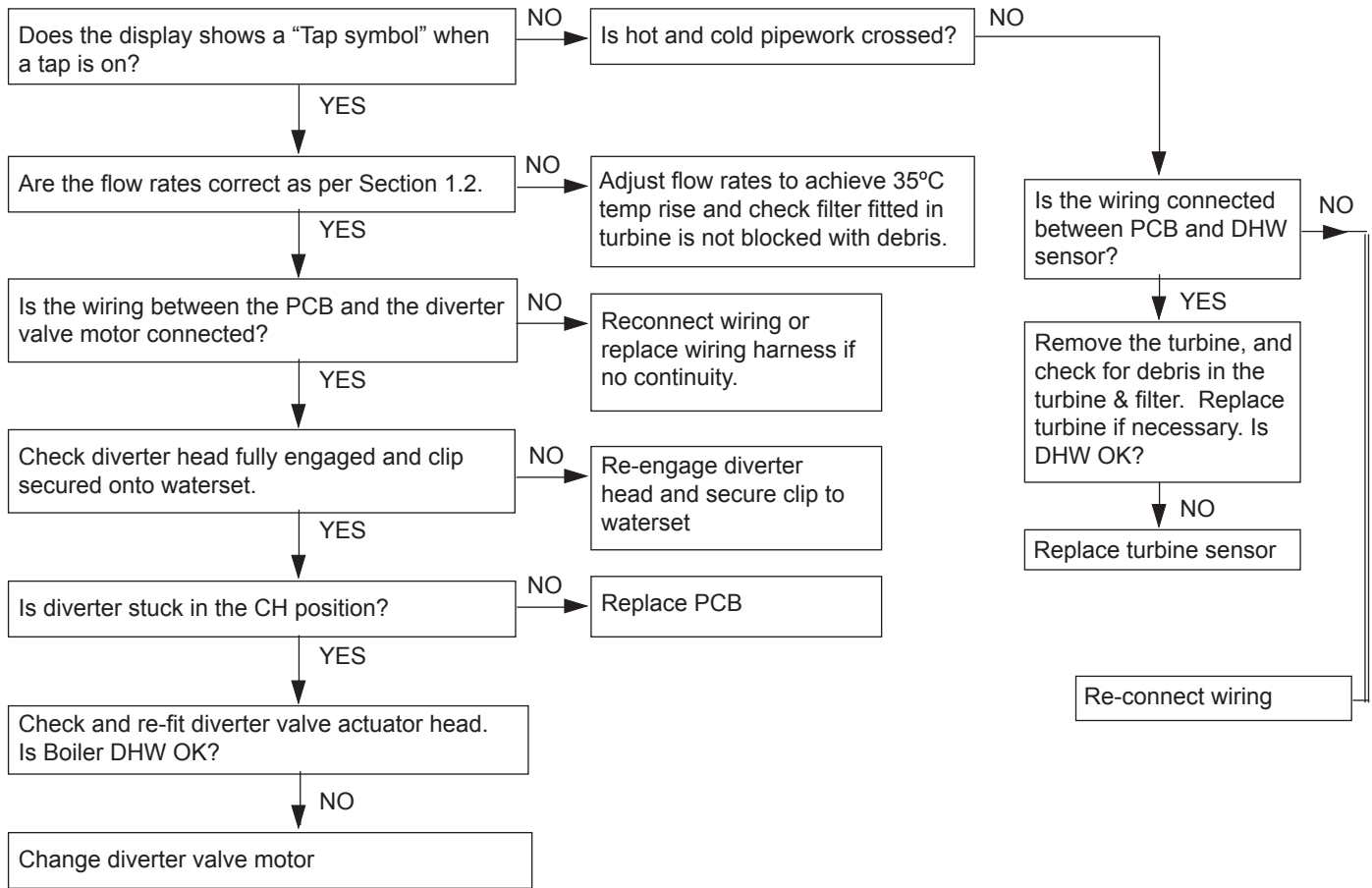

### 4.13 NO DISPLAY

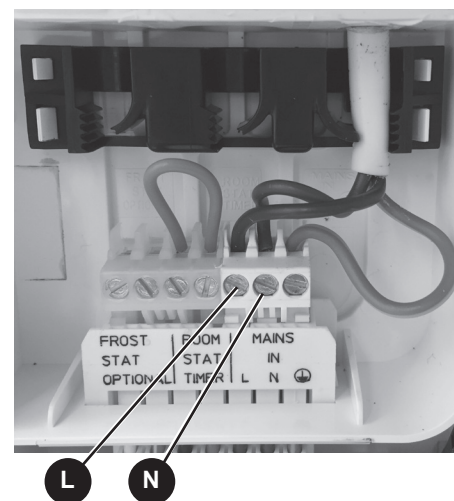
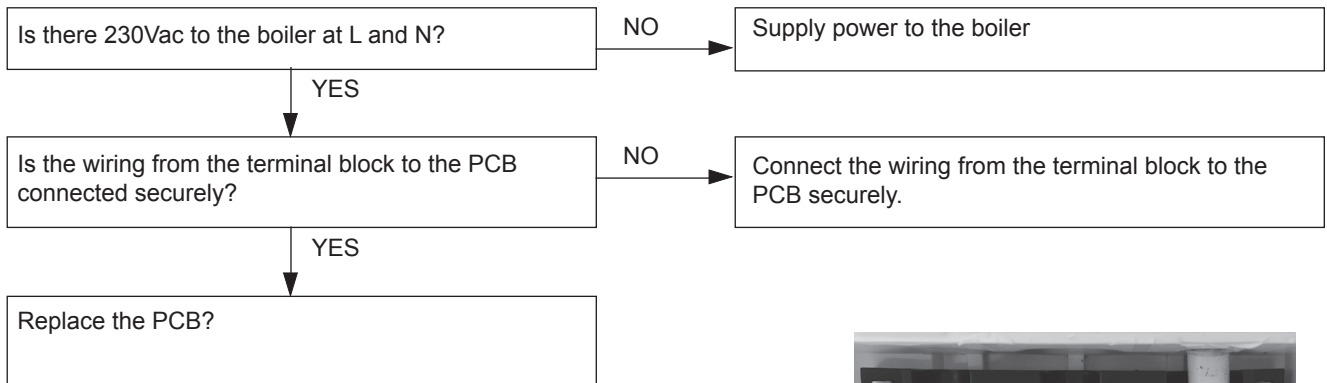

## SECTION 5 - SPARE PARTS

---

When replacing any part on this appliance use only spare parts that you can be assured conform to the safety and performance specification that we require. Do not use reconditioned or copy parts that have not been clearly authorised by Ideal. Failure to do so could affect safety or performance of this appliance.

Comprehensive spares parts information and details of approved Ideal Parts Distributors are available on [idealparts.com](http://idealparts.com)

**Our Parts team are also available to help with your Ideal Spare Parts enquiries on 01482 498665.**

When calling, and to ensure we can provide you with the most accurate parts information, please ensure you have the following to hand;

- Boiler Model
- Appliance GC Number
- Boiler Serial Number

### **IMPORTANT NOTE.**

**Propane Boilers** - After installation of a conversion kit, and when ordering future spares be sure to quote the serial letter code AAV - which indicates a Propane boiler - and the boilers original serial letter code from the original data plate.

# Code Of Practice

For the installation, commissioning and servicing of domestic heating and hot water products

Benchmark places responsibilities on both manufacturers and installers.\* The purpose is to ensure that customers\*\* are provided with the correct equipment for their needs, that it is installed, commissioned and serviced in accordance with the manufacturer's instructions by competent persons and that it meets the requirements of the appropriate Building Regulations. Installers are required to carry out work in accordance with the following:

## Standards of Work

- Be competent and qualified to undertake the work required.
- Install, commission, service and use products in accordance with the manufacturer's instructions provided.
- Ensure that where there is responsibility for design work, the installation is correctly sized and fit for purpose.
- Meet the requirements of the appropriate Building Regulations. Where this involves notifiable work be a member of a Competent Persons Scheme or confirm that the customer has notified Local Authority Building Control (LABC), prior to work commencing.
- Complete all relevant sections of the Benchmark Checklist/Service Record when carrying out commissioning or servicing of a product or system.
- Ensure that the product or system is left in a safe condition and, whenever possible, in good working order.
- Highlight to the customer any remedial or improvement work identified during the course of commissioning or servicing work.
- Refer to the manufacturer's helpline where assistance is needed.
- Report product faults and concerns to the manufacturer in a timely manner.

## Customer Service

- Show the customer any identity card that is relevant to the work being carried out prior to commencement or on request.
- Give a full and clear explanation/demonstration of the product or system and its operation to the customer.
- Hand over the manufacturer's instructions, including the Benchmark Checklist, to the customer on completion of an installation.
- Obtain the customer's signature, on the Benchmark Checklist, to confirm satisfactory demonstration and receipt of manufacturer's instructions.
- Advise the customer that regular product servicing is needed, in line with manufacturers' recommendations, to ensure that safety and efficiency is maintained.
- Respond promptly to calls from a customer following completion of work, providing advice and assistance by phone and, if necessary, visiting the customer.
- Rectify any installation problems at no cost to the customer during the installer's guarantee period.



\*The use of the word "installer" is not limited to installation itself and covers those carrying out installation, commissioning and/or servicing of heating and hot water products, or the use of supporting products (such as water treatment or test equipment).

\*\*Customer includes householders, landlords and tenants.

# Benchmark Commissioning & Warranty Validation Service Record

It is a requirement that the boiler is installed and commissioned to the manufacturers' instructions and the data fields on the commissioning checklist completed in full.

To instigate the boiler warranty the boiler needs to be registered with the manufacturer within one month of the installation. The warranty rests with the end-user (consumer), and they should be made aware it is ultimately their responsibility to register with the manufacturer, within the allotted time period.

It is essential that the boiler is serviced in line with the manufacturers' recommendations, at least annually. This must be carried out by a competent Gas Safe registered engineer. The service details should be recorded on the Benchmark Service and Interim Boiler Work Record and left with the householder. Failure to comply with the manufacturers' servicing instructions and requirements will invalidate the warranty.



[www.hhic.co.uk](http://www.hhic.co.uk)

**This Commissioning Checklist is to be completed in full by the competent person who commissioned the boiler as a means of demonstrating compliance with the appropriate Building Regulations and then handed to the customer to keep for future reference.**

Failure to install and commission according to the manufacturers' instructions and complete this Benchmark Commissioning Checklist will invalidate the warranty. This does not affect the customer's statutory rights.

\* All installations in England and Wales must be notified to Local Authority Building Control (LABC) either directly or through a Competent Persons Scheme. A Building Regulations Compliance Certificate will then be issued to the customer.

© Heating and Hotwater Industry Council (HHIC)



[www.centralheating.co.uk](http://www.centralheating.co.uk)

## GAS BOILER SYSTEM COMMISSIONING CHECKLIST & WARRANTY VALIDATION RECORD

Address:													
Boiler make and model:													
Boiler serial number:													
Commissioned by (PRINT NAME):						Gas Safe registration number:							
Company name:						Telephone number:							
Company email:						Company address:							
										Commissioning date:			
Heating and hot water system complies with the appropriate Building Regulations?											Yes		
Optional: Building Regulations Notification Number (if applicable):													
Time, temperature control and boiler interlock provided for central heating and hot water											Yes		
Boiler Plus requirements (tick the appropriate box(s))													
Boiler Plus option chosen for combination boiler in ENGLAND						Weather compensation			Smart thermostat with automisation and optimisation				
						Load compensation			Flue Gas Heat Recovery				
Time and temperature control to hot water			Cylinder thermostat and programmer/timer						Combination boiler				
Zone valves			pre-existing			Fitted			Not required				
Thermostatic radiator valves			pre-existing			Fitted			Not required				
Automatic bypass to system			pre-existing			Fitted			Not required				
Underfloor heating			pre-existing			Fitted			Not required				
Water quality													
The system has been flushed, cleaned and a suitable inhibitor applied upon final fill, in accordance with BS7593 and boiler manufacturers' instructions											Yes		
What system cleaner was used?						Brand:			Product:				
What inhibitor was used?						Brand:			Product:				
Primary water system filter			pre-existing			Fitted			Not required				
CENTRAL HEATING MODE measure and record (as appropriate)													
Gas rate (for combination boilers complete DHW mode gas rate)						m <sup>3</sup> /hr			or		ft <sup>3</sup> /hr		
Central heating output left at factory settings?											Yes	No	
If no, what is the maximum central heating output selected?													kW
Dynamic gas inlet pressure													mbar
Central heating flow temperature													°C
Central heating return temperature													°C
System correctly balanced/rebalanced?													Yes
COMBINATION BOILERS ONLY													
Is the installation in a hard water area (above 200ppm)?						Yes			No				
Water scale reducer/softener			pre-existing			Fitted			Not required				
What type of scale reducer/softener has been fitted?						Brand:			Product:				
Water meter fitted?						Yes			No				
If yes- DHW expansion vessel			pre-existing			Fitted			Not required				
Pressure reducing valve			pre-existing			Fitted			Not required				
DOMESTIC HOT WATER MODE Measure and record													
Gas rate						m <sup>3</sup> /hr			or		ft <sup>3</sup> /hr		
Dynamic gas inlet pressure at maximum rate													mbar
Cold water inlet temperature													°C
Hot water has been checked at all outlets						Yes			Temperature		°C		
CONDENSATE DISPOSAL													
The condensate drain has been installed in accordance with the manufacturers' instructions and/or BS5546/BS6798													Yes
Point of termination						Internal			External (only where internal termination impractical)				
Method of disposal						Gravity			Pumped				
ALL INSTALLATIONS													
Record the following		At max rate:		CO ppm		CO <sub>2</sub> %		CO/CO <sub>2</sub>		Ratio			
		At min rate (where possible)		CO ppm		CO <sub>2</sub> %		CO/CO <sub>2</sub>		Ratio			
Where possible, has a flue integrity check been undertaken in accordance with manufacturers' instructions, and readings are correct?											Yes		
The operation of the boiler and system controls have been demonstrated to and understood by the customer											Yes		
The manufacturers' literature, including Benchmark Checklist and Service Record, has been explained and left with the customer											Yes		
Commissioning Engineer's signature													
Customer's signature (To confirm satisfactory demonstration and receipt of manufacturers' literature)													

\* All installations in England and Wales must be notified to Local Authority Building Control (LABC) either directly or through a Competent Persons Scheme. A Building Regulations Compliance Certificate will then be issued to the customer.

© Heating and Hotwater Industry Council (HHIC)



www.centralheating.co.uk

# SERVICE & INTERIM BOILER WORK RECORD

It is recommended that your boiler and heating system are regularly serviced and maintained, in line with manufacturers' instructions, and that the appropriate service / interim work record is completed.

## Service provider

When completing a service record (as below), please ensure you have carried out the service as described in the manufacturers' instructions. Always use the manufacturers' specified spare parts.

SERVICE/INTERIM WORK ON BOILER <small>delete as appropriate</small>					Date:
Engineer name:		Company name:			
Telephone N°:		Gas Safe registration N°:			
Max rate	CO	ppm	CO <sub>2</sub>	%	CO/CO <sub>2</sub>
Min rate	CO	ppm	CO <sub>2</sub>	%	CO/CO <sub>2</sub>
Where possible, has a flue integrity check been undertaken in accordance with manufacturers' instructions, and readings are correct?*					yes
Gas rate:	m <sup>3</sup> /h	OR	ft <sup>3</sup> /h		
Were parts fitted? <small>delete as appropriate</small>	Yes	No			
Parts fitted:					
System inhibitor concentration has been checked and appropriate action taken, in accordance with BS 7593 and boiler manufacturers' instructions. *					yes      n/a
Comments:					
Signature:					

\*A System inhibitor efficacy test is required on every annual service in accordance with the manufacturers' instructions and BS 7593. It is only acceptable to not have undertaken this if the service engineers attendance visit was in between annual services to attend a non-water facing component.

SERVICE/INTERIM WORK ON BOILER <small>delete as appropriate</small>					Date:
Engineer name:		Company name:			
Telephone N°:		Gas Safe registration N°:			
Max rate	CO	ppm	CO <sub>2</sub>	%	CO/CO <sub>2</sub>
Min rate	CO	ppm	CO <sub>2</sub>	%	CO/CO <sub>2</sub>
Where possible, has a flue integrity check been undertaken in accordance with manufacturers' instructions, and readings are correct?*					yes
Gas rate:	m <sup>3</sup> /h	OR	ft <sup>3</sup> /h		
Were parts fitted? <small>delete as appropriate</small>	Yes	No			
Parts fitted:					
System inhibitor concentration has been checked and appropriate action taken, in accordance with BS 7593 and boiler manufacturers' instructions. *					yes      n/a
Comments:					
Signature:					

\*A System inhibitor efficacy test is required on every annual service in accordance with the manufacturers' instructions and BS 7593. It is only acceptable to not have undertaken this if the service engineers attendance visit was in between annual services to attend a non-water facing component.

SERVICE/INTERIM WORK ON BOILER <small>delete as appropriate</small>					Date:
Engineer name:		Company name:			
Telephone N°:		Gas Safe registration N°:			
Max rate	CO	ppm	CO <sub>2</sub>	%	CO/CO <sub>2</sub>
Min rate	CO	ppm	CO <sub>2</sub>	%	CO/CO <sub>2</sub>
Where possible, has a flue integrity check been undertaken in accordance with manufacturers' instructions, and readings are correct?*					yes
Gas rate:	m <sup>3</sup> /h	OR	ft <sup>3</sup> /h		
Were parts fitted? <small>delete as appropriate</small>	Yes	No			
Parts fitted:					
System inhibitor concentration has been checked and appropriate action taken, in accordance with BS 7593 and boiler manufacturers' instructions. *					yes      n/a
Comments:					
Signature:					

\*A System inhibitor efficacy test is required on every annual service in accordance with the manufacturers' instructions and BS 7593. It is only acceptable to not have undertaken this if the service engineers attendance visit was in between annual services to attend a non-water facing component.

SERVICE/INTERIM WORK ON BOILER <small>delete as appropriate</small>					Date:
Engineer name:		Company name:			
Telephone N°:		Gas Safe registration N°:			
Max rate	CO	ppm	CO <sub>2</sub>	%	CO/CO <sub>2</sub>
Min rate	CO	ppm	CO <sub>2</sub>	%	CO/CO <sub>2</sub>
Where possible, has a flue integrity check been undertaken in accordance with manufacturers' instructions, and readings are correct?*					yes
Gas rate:	m <sup>3</sup> /h	OR	ft <sup>3</sup> /h		
Were parts fitted? <small>delete as appropriate</small>	Yes	No			
Parts fitted:					
System inhibitor concentration has been checked and appropriate action taken, in accordance with BS 7593 and boiler manufacturers' instructions. *					yes      n/a
Comments:					
Signature:					

\*A System inhibitor efficacy test is required on every annual service in accordance with the manufacturers' instructions and BS 7593. It is only acceptable to not have undertaken this if the service engineers attendance visit was in between annual services to attend a non-water facing component.

SERVICE/INTERIM WORK ON BOILER <small>delete as appropriate</small>					Date:
Engineer name:		Company name:			
Telephone N°:		Gas Safe registration N°:			
Max rate	CO	ppm	CO <sub>2</sub>	%	CO/CO <sub>2</sub>
Min rate	CO	ppm	CO <sub>2</sub>	%	CO/CO <sub>2</sub>
Where possible, has a flue integrity check been undertaken in accordance with manufacturers' instructions, and readings are correct?*					yes
Gas rate:	m <sup>3</sup> /h	OR	ft <sup>3</sup> /h		
Were parts fitted? <small>delete as appropriate</small>	Yes	No			
Parts fitted:					
System inhibitor concentration has been checked and appropriate action taken, in accordance with BS 7593 and boiler manufacturers' instructions. *					yes      n/a
Comments:					
Signature:					

\*A System inhibitor efficacy test is required on every annual service in accordance with the manufacturers' instructions and BS 7593. It is only acceptable to not have undertaken this if the service engineers attendance visit was in between annual services to attend a non-water facing component.

SERVICE/INTERIM WORK ON BOILER <small>delete as appropriate</small>					Date:
Engineer name:		Company name:			
Telephone N°:		Gas Safe registration N°:			
Max rate	CO	ppm	CO <sub>2</sub>	%	CO/CO <sub>2</sub>
Min rate	CO	ppm	CO <sub>2</sub>	%	CO/CO <sub>2</sub>
Where possible, has a flue integrity check been undertaken in accordance with manufacturers' instructions, and readings are correct?*					yes
Gas rate:	m <sup>3</sup> /h	OR	ft <sup>3</sup> /h		
Were parts fitted? <small>delete as appropriate</small>	Yes	No			
Parts fitted:					
System inhibitor concentration has been checked and appropriate action taken, in accordance with BS 7593 and boiler manufacturers' instructions. *					yes      n/a
Comments:					
Signature:					

\*A System inhibitor efficacy test is required on every annual service in accordance with the manufacturers' instructions and BS 7593. It is only acceptable to not have undertaken this if the service engineers attendance visit was in between annual services to attend a non-water facing component.

\* All installations in England and Wales must be notified to Local Authority Building Control (LABC) either directly or through a Competent Persons Scheme. A Building Regulations Compliance Certificate will then be issued to the customer.

© Heating and Hotwater Industry Council (HHIC)



www.centralheating.co.uk

Installation and Servicing

# SERVICE & INTERIM BOILER WORK RECORD

It is recommended that your boiler and heating system are regularly serviced and maintained, in line with manufacturers' instructions, and that the appropriate service / interim work record is completed.

## Service provider

When completing a service record (as below), please ensure you have carried out the service as described in the manufacturers' instructions. Always use the manufacturers specified spare parts.

SERVICE/INTERIM WORK ON BOILER <small>delete as appropriate</small>				Date:	
Engineer name:		Company name:			
Telephone N°:		Gas Safe registration N°:			
Max rate	CO	ppm	CO <sub>2</sub>	% CO/CO <sub>2</sub>	
Min rate	CO	ppm	CO <sub>2</sub>	% CO/CO <sub>2</sub>	
Where possible, has a flue integrity check been undertaken in accordance with manufacturers' instructions, and readings are correct?*				yes	
Gas rate:	m <sup>3</sup> /h	OR	ft <sup>3</sup> /h		
Were parts fitted? <small>delete as appropriate</small>		Yes	No		
Parts fitted:					
System inhibitor concentration has been checked and appropriate action taken, in accordance with BS 7593 and boiler manufacturers' instructions. *				yes	n/a
Comments:					
Signature:					

\*A System inhibitor efficacy test is required on every annual service in accordance with the manufacturers' instructions and BS 7593. It is only acceptable to not have undertaken this if the service engineers attendance visit was in between annual services to attend a non-water facing component.

SERVICE/INTERIM WORK ON BOILER <small>delete as appropriate</small>				Date:	
Engineer name:		Company name:			
Telephone N°:		Gas Safe registration N°:			
Max rate	CO	ppm	CO <sub>2</sub>	% CO/CO <sub>2</sub>	
Min rate	CO	ppm	CO <sub>2</sub>	% CO/CO <sub>2</sub>	
Where possible, has a flue integrity check been undertaken in accordance with manufacturers' instructions, and readings are correct?*				yes	
Gas rate:	m <sup>3</sup> /h	OR	ft <sup>3</sup> /h		
Were parts fitted? <small>delete as appropriate</small>		Yes	No		
Parts fitted:					
System inhibitor concentration has been checked and appropriate action taken, in accordance with BS 7593 and boiler manufacturers' instructions. *				yes	n/a
Comments:					
Signature:					

\*A System inhibitor efficacy test is required on every annual service in accordance with the manufacturers' instructions and BS 7593. It is only acceptable to not have undertaken this if the service engineers attendance visit was in between annual services to attend a non-water facing component.

SERVICE/INTERIM WORK ON BOILER <small>delete as appropriate</small>				Date:	
Engineer name:		Company name:			
Telephone N°:		Gas Safe registration N°:			
Max rate	CO	ppm	CO <sub>2</sub>	% CO/CO <sub>2</sub>	
Min rate	CO	ppm	CO <sub>2</sub>	% CO/CO <sub>2</sub>	
Where possible, has a flue integrity check been undertaken in accordance with manufacturers' instructions, and readings are correct?*				yes	
Gas rate:	m <sup>3</sup> /h	OR	ft <sup>3</sup> /h		
Were parts fitted? <small>delete as appropriate</small>		Yes	No		
Parts fitted:					
System inhibitor concentration has been checked and appropriate action taken, in accordance with BS 7593 and boiler manufacturers' instructions. *				yes	n/a
Comments:					
Signature:					

\*A System inhibitor efficacy test is required on every annual service in accordance with the manufacturers' instructions and BS 7593. It is only acceptable to not have undertaken this if the service engineers attendance visit was in between annual services to attend a non-water facing component.

SERVICE/INTERIM WORK ON BOILER <small>delete as appropriate</small>				Date:	
Engineer name:		Company name:			
Telephone N°:		Gas Safe registration N°:			
Max rate	CO	ppm	CO <sub>2</sub>	% CO/CO <sub>2</sub>	
Min rate	CO	ppm	CO <sub>2</sub>	% CO/CO <sub>2</sub>	
Where possible, has a flue integrity check been undertaken in accordance with manufacturers' instructions, and readings are correct?*				yes	
Gas rate:	m <sup>3</sup> /h	OR	ft <sup>3</sup> /h		
Were parts fitted? <small>delete as appropriate</small>		Yes	No		
Parts fitted:					
System inhibitor concentration has been checked and appropriate action taken, in accordance with BS 7593 and boiler manufacturers' instructions. *				yes	n/a
Comments:					
Signature:					

\*A System inhibitor efficacy test is required on every annual service in accordance with the manufacturers' instructions and BS 7593. It is only acceptable to not have undertaken this if the service engineers attendance visit was in between annual services to attend a non-water facing component.

SERVICE/INTERIM WORK ON BOILER <small>delete as appropriate</small>				Date:	
Engineer name:		Company name:			
Telephone N°:		Gas Safe registration N°:			
Max rate	CO	ppm	CO <sub>2</sub>	% CO/CO <sub>2</sub>	
Min rate	CO	ppm	CO <sub>2</sub>	% CO/CO <sub>2</sub>	
Where possible, has a flue integrity check been undertaken in accordance with manufacturers' instructions, and readings are correct?*				yes	
Gas rate:	m <sup>3</sup> /h	OR	ft <sup>3</sup> /h		
Were parts fitted? <small>delete as appropriate</small>		Yes	No		
Parts fitted:					
System inhibitor concentration has been checked and appropriate action taken, in accordance with BS 7593 and boiler manufacturers' instructions. *				yes	n/a
Comments:					
Signature:					

\*A System inhibitor efficacy test is required on every annual service in accordance with the manufacturers' instructions and BS 7593. It is only acceptable to not have undertaken this if the service engineers attendance visit was in between annual services to attend a non-water facing component.

SERVICE/INTERIM WORK ON BOILER <small>delete as appropriate</small>				Date:	
Engineer name:		Company name:			
Telephone N°:		Gas Safe registration N°:			
Max rate	CO	ppm	CO <sub>2</sub>	% CO/CO <sub>2</sub>	
Min rate	CO	ppm	CO <sub>2</sub>	% CO/CO <sub>2</sub>	
Where possible, has a flue integrity check been undertaken in accordance with manufacturers' instructions, and readings are correct?*				yes	
Gas rate:	m <sup>3</sup> /h	OR	ft <sup>3</sup> /h		
Were parts fitted? <small>delete as appropriate</small>		Yes	No		
Parts fitted:					
System inhibitor concentration has been checked and appropriate action taken, in accordance with BS 7593 and boiler manufacturers' instructions. *				yes	n/a
Comments:					
Signature:					

\*A System inhibitor efficacy test is required on every annual service in accordance with the manufacturers' instructions and BS 7593. It is only acceptable to not have undertaken this if the service engineers attendance visit was in between annual services to attend a non-water facing component.

\* All installations in England and Wales must be notified to Local Authority Building Control (LABC) either directly or through a Competent Persons Scheme. A Building Regulations Compliance Certificate will then be issued to the customer.

© Heating and Hotwater Industry Council (HHIC)



www.centralheating.co.uk

# FLOWCHART FOR CO LEVEL AND COMBUSTION RATIO CHECK ON COMMISSIONING A CONDENSING BOILER

## Important Preliminary Information on Checks

The air gas ratio valve is factory-set and must not be adjusted DURING COMMISSIONING.

If the boiler requires conversion to operate with a different gas family (e.g. conversion from natural gas to LPG) separate guidance is provided with the conversion kit supplied and this must be followed.

### PRIOR TO CO LEVEL AND COMBUSTION RATIO CHECK

The installation instructions must have been followed, gas type verified and gas supply pressure / gas rate checked as required prior to commissioning.

As part of the installation process, ESPECIALLY WHERE A FLUE HAS BEEN FITTED BY PERSONS OTHER THAN THE BOILER INSTALLER, visually check the integrity of the whole flue system to confirm that all components are correctly assembled, fixed and supported. Check that maximum flue lengths have not been exceeded and all guidance has been followed (e.g. Gas Safe Register Technical Bulletin (TB) 008 where chimney/flues are in voids).

The ECGA should be of the correct type, as specified by BS 7967.

Prior to its use, the ECGA should have been maintained and calibrated as specified by the manufacturer. The installer must have the relevant competence for use of the analyser.

Check and zero the analyser IN FRESH AIR in accordance with the analyser manufacturer's instructions.

#### KEY:

**CO** = carbon monoxide

**CO<sub>2</sub>** = carbon dioxide

**O<sub>2</sub>** = oxygen

**Combustion Ratio** = The CO reading measured in ppm divided by the CO<sub>2</sub> reading first converted to ppm

**ppm** = parts per million

**GS(I&U)R** = Gas Safety (Installation and Use) Regulations

**IMPORTANT:** Ensure boiler is in normal operation with a heat demand before setting Maximum / Minimum rate function.

#### Setting to Maximum Rate:

1. Hold "RESTART" & Function buttons together for more than 5s
2. Last 3 faults will be shown
3. SL shown, press the Function button
4. SH shown, press "RESTART"
5. Burner will run for 10 minutes at maximum rate.
6. Press "RESTART" to exit Maximum rate mode.

#### \*Setting to Minimum Rate:

1. Hold "RESTART" & Function buttons together for more than 5s
2. Last 3 faults will be shown
3. SL shown, press "RESTART"
4. If the return temperature is under 40 °C the fan will run for 90 seconds starting at maximum.
5. The boiler will reduce to minimum rate for 10 minutes unless manually overridden.
6. Press "RESTART" to exit Minimum Rate mode.

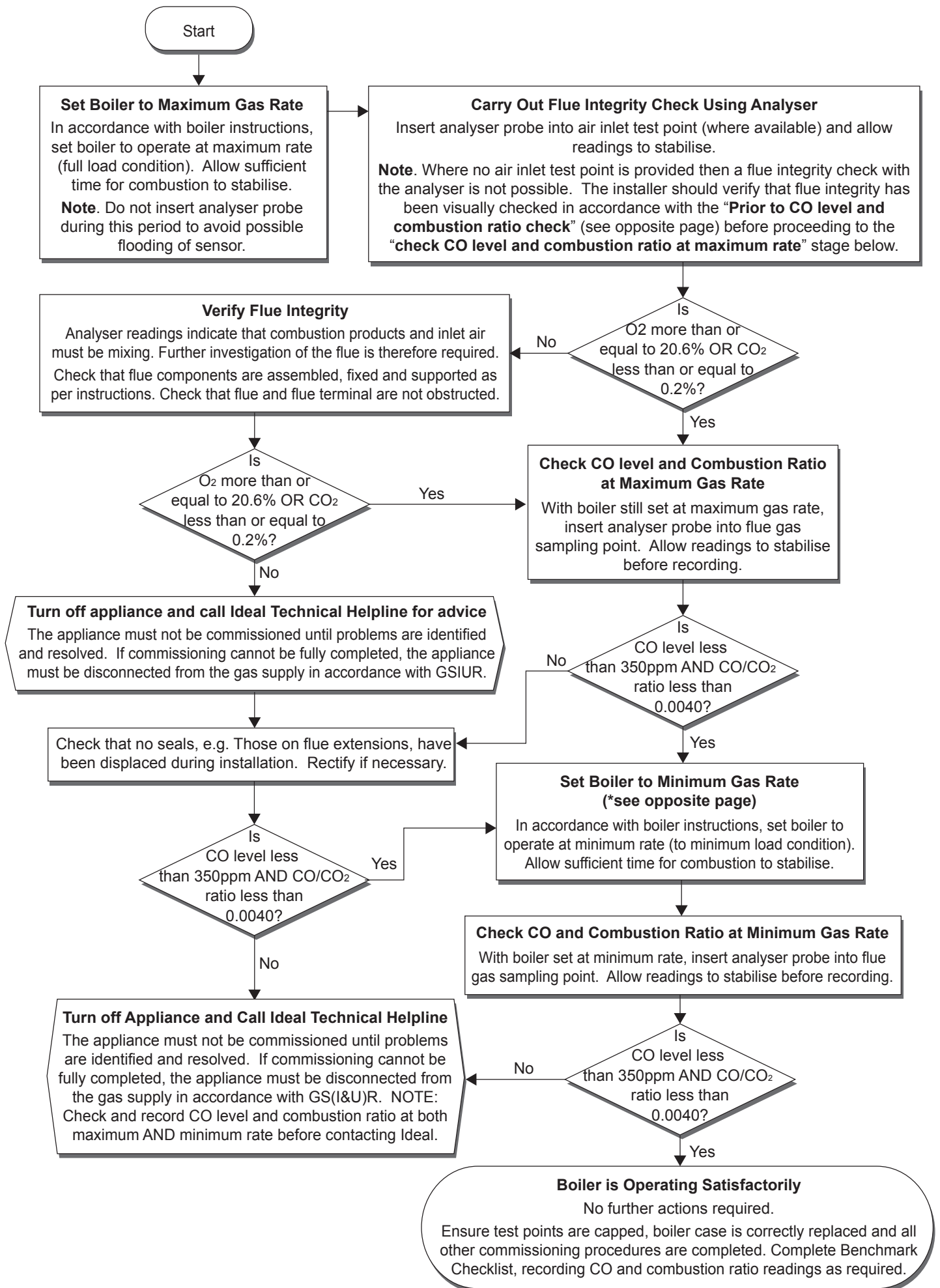

## NOTES

## NOTES



**WEEE DIRECTIVE 2012/19/EU**  
**Waste Electrical and Electronic Equipment Directive**

- At the end of the product life, dispose of the packaging and product in a corresponding recycle centre.
- Do not dispose of the unit with the usual domestic refuse.
- Do not burn the product.
- Remove the batteries.
- Dispose of the batteries according to the local statutory requirements and not with the usual domestic refuse.



FM 59915  
Manufactured under  
an ISO 9001  
registered quality  
management system



The code of practice for the installation, commissioning  
& servicing of central heating systems

At Ideal Heating we take our environmental impact seriously, therefore when installing any Ideal Heating product please make sure to dispose of any previous appliance in an environmentally conscious manner. Households can contact their local authority to find out how. See <https://www.gov.uk/managing-your-waste-an-overview> for guidance on how to efficiently recycle your business waste.

### Technical Training

Our Expert Academy offer a range of training options designed and delivered by our experts in heating. For details please contact:  
[expert-academy.co.uk](http://expert-academy.co.uk)

Ideal Boilers Ltd., pursues a policy of continuing improvement in the design and performance of its products. The right is therefore reserved to vary specification without notice.

Ideal is a trademark of Ideal Heating.

Registered Office

Ideal Boilers Ltd., National Avenue, Hull, East Yorkshire, HU5 4JB

Tel 01482 492251 Fax 01482 448858

Registration No. London 322 137

EU Authorised Representative:

Atlantic SFDT

44 Boulevard des Etats-Unis, 85 000 La Roche-Sur-Yon, France

+33 (0)2 51 44 34 34

Ideal Technical Helpline: 01482 498663

Ideal Consumer Helpline: 01482 498660

Ideal Parts: 01482 498665

[idealheating.com](http://idealheating.com)

**ideal**  
HEATING