

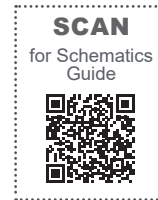

SCHEMATICS

LOGIC AIR MONOBLOC HEAT PUMP SYSTEM



When replacing any part on this appliance, use only spare parts that you can be assured conform to the safety and performance specification that we require. Do not use reconditioned or copy parts that have not been clearly authorised by Ideal Heating.

For the very latest copy of literature for specification and maintenance practices visit our website idealheating.com where you can download the relevant information in PDF format.





**WEEE DIRECTIVE 2012/19/EU
Waste Electrical and Electronic Equipment Directive**

- At the end of the product life, dispose of the packaging and product in a corresponding recycle centre.
- Do not dispose of the unit with the usual domestic refuse.
- Do not burn the product.
- Remove the batteries.
- Dispose of the batteries according to the local statutory requirements and not with the usual domestic refuse.



The code of practice for the installation,
commissioning & servicing of central
heating systems



Ideal Heating reserve the right to vary specification without notice

CONTENTS

Figure 1. Legend	4
Figure 2. Logic Air + Single Zone Pre-Plumbed Cylinder with Integrated Buffer	5
Figure 3. Logic Air + Two Zone Pre-Plumbed Cylinder with Integrated Buffer	6
Figure 4. Logic Air + Single Zone Pre-Plumbed Cylinder	7
Figure 5. Logic Air + Standard Non Pre-Plumbed Heat Pump Cylinder + Buffer with Single Zone.....	8
Figure 6. Logic Air + Standard Non Pre-Plumbed Heat Pump Cylinder + Buffer with Two Zones	9
Figure 7. Logic Air + Single Zone Pre-Plumbed Cylinder + External Buffer with Two Zones	10
Figure 8. Logic Air + Two Zone Pre-Plumbed Cylinder with Integrated Low Loss Header	11
Figure 9. Logic Air Three Zone + Two Zone Pre-Plumbed Cylinder with Integrated Buffer (Note, requires additional 3rd party electrical wiring for a 3rd zone).....	12
Figure 10. Logic Air Three Zone + Two Zone Pre-Plumbed Cylinder with Integrated Low Loss Header (Note, requires additional 3rd party electrical wiring for a 3rd zone).....	13
Figure 11. Logic Air + Decoupling Buffer for Heating Only with Two Zones	14
Figure 12. Logic Air + Combi Boiler + Single Zone without Buffer (Bivalent System)	15
Figure 13. Logic Air + Combi Boiler + Buffer + Single Zone (Bivalent System).....	16
Figure 14. Logic Air + Combi Boiler + Buffer + Two Zones (Bivalent System)	17
Figure 15. Logic Air + Heating Only + System Boiler + Buffer with Two Zones (Bivalent System)	18
Figure 16. Logic Air + Heat Only Boiler Backup + Single Zone	19
Figure 17. Logic Air + Heat Only Boiler Backup + Buffer with Two Zones.....	20
Figure 18. Logic Air + System Boiler + Two Zone Pre-Plumbed Cylinder with Integrated Buffer	21
Figure 19. Hydraulically Separated Logic Air + System Boiler + DHW + Two Zones (Bivalent System) ..	22
Figure 20. Logic Air Monobloc Cascade Heat Only, Decoupler with Two Zones.....	23
Figure 21. Logic Air Monobloc Cascade, Third Party DHW Cylinder, Decoupler with Two Zones	24
Figure 22. Logic Air Monobloc Cascade + Third Party DHW Cylinder + Multi-Port Decoupler with Two Zones	25
Figure 23. Logic Air Monobloc Cascade Heat Only + Multi-Port Decoupler with Two Zones.....	26

ⓘ IMPORTANT: PLEASE USE THIS MANUAL IN CONJUNCTION WITH THE LOGIC AIR MONOBLOC HEAT PUMP SYSTEM – INSTALLATION & SERVICING MANUAL

Figure 1. Legend

1. LEGEND

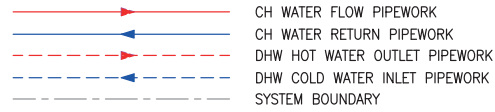

COMPONENT SYMBOLS

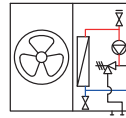
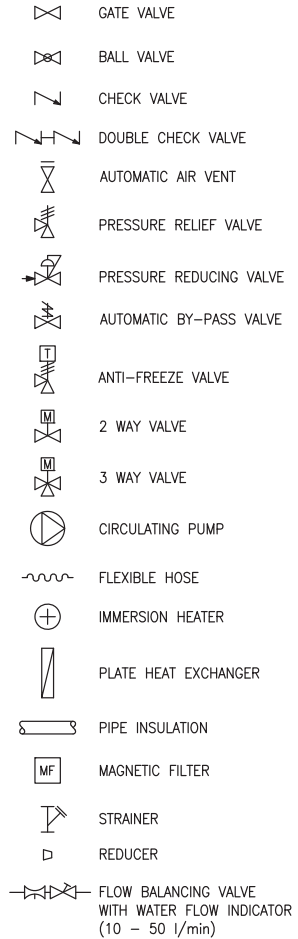

MONOBLOCK HEAT PUMP

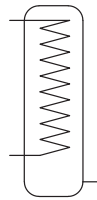

INDIRECT DHW CYLINDER



HEAT EMITTER



EXPANSION VESSEL



VOLUMISER

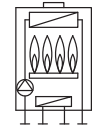

COMBINATION BOILER

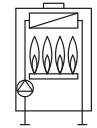

SYSTEM BOILER

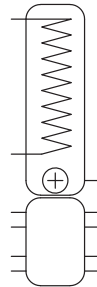

INDIRECT DHW CYLINDER WITH INTEGRATED BUFFER TANK



MULTI CONNECTION BUFFER TANK



MULTI CONNECTION HYDRAULIC SEPARATOR



HYDRAULIC SEPARATOR

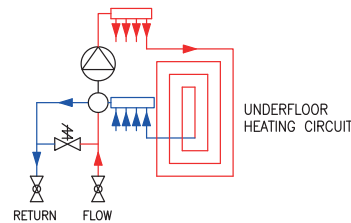

UNDERFLOOR HEATING CIRCUIT

INSTRUMENT ABBREVIATIONS
(LOGIC AIR CONTROL BOX CONNECTIONS)

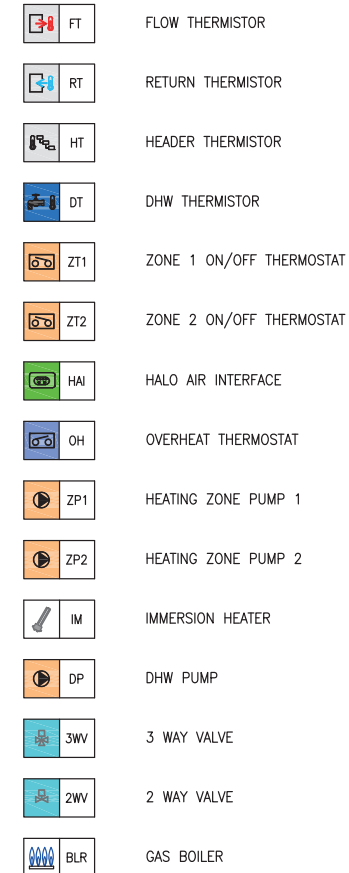

Refer to Logic Air monobloc heat pump system installation and maintenance manual in conjunction with these schematic drawings.

CONNECTION POINT LIST				
TP No	DESCRIPTION	SIZE	MATERIAL	TYPE
1	HEAT PUMP FLOW	1" BSP	BRASS	BSP MALE
2	HEAT PUMP RETURN	1" BSP	BRASS	BSP MALE
3	HEAT PUMP CONDENSATE DISPOSAL	-	-	-
4	PRESSURE RELIEF VALVE (PRV)	15MM	COPPER	COPPER PIPE OUTLET
5	CYLINDER HEAT PUMP FLOW	28MM	BRASS	COMPRESSION
6	CYLINDER HEAT PUMP RETURN	28MM	BRASS	COMPRESSION
7	ZONE 1 FLOW	28MM	BRASS	COMPRESSION
8	ZONE 1 RETURN	28MM	BRASS	COMPRESSION

Figure 2. Logic Air + Single Zone Pre-Plumbed Cylinder with Integrated Buffer

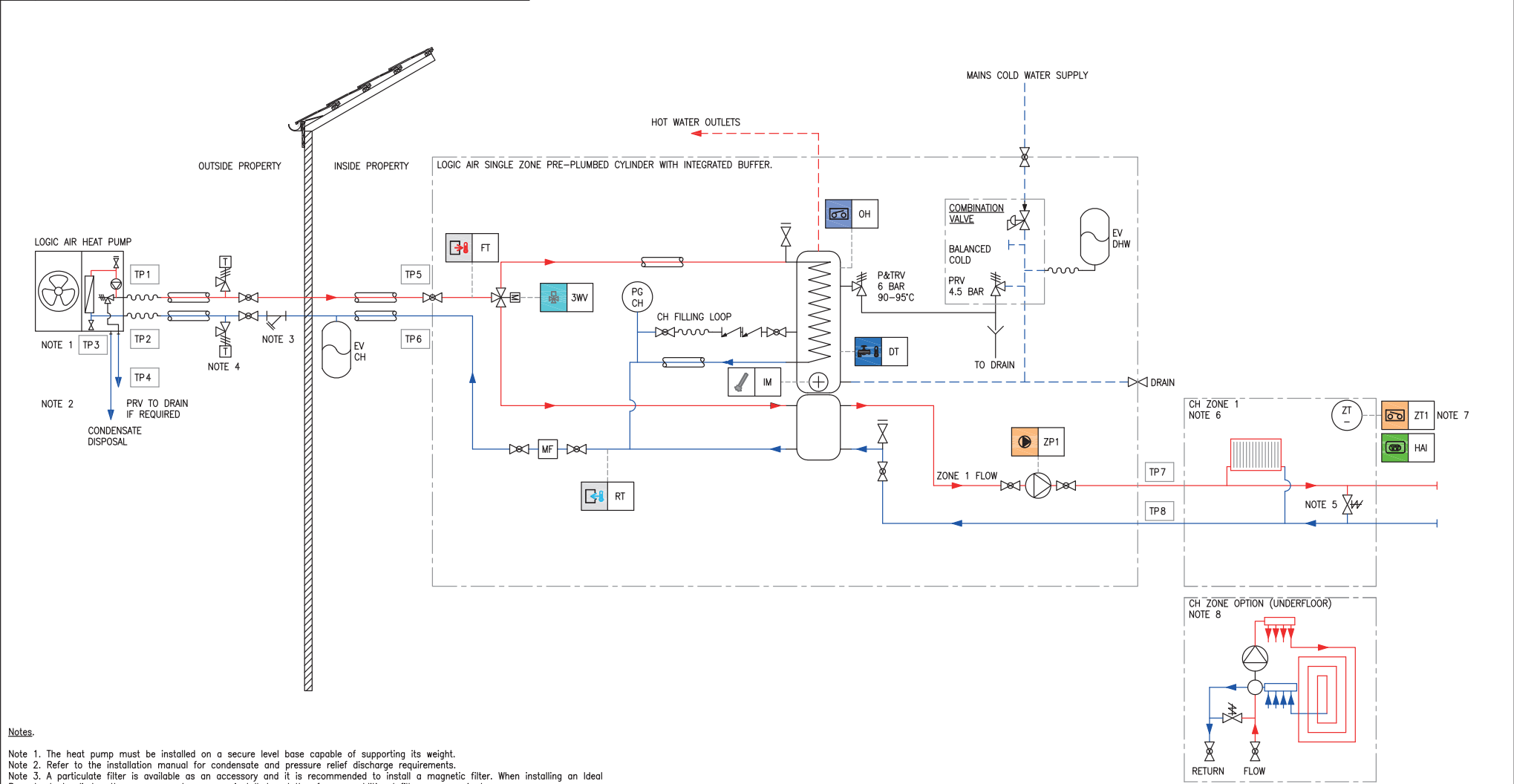

- Notes:
- Note 1. The heat pump must be installed on a secure level base capable of supporting its weight.
 - Note 2. Refer to the installation manual for condensate and pressure relief discharge requirements.
 - Note 3. A particulate filter is available as an accessory and it is recommended to install a magnetic filter. When installing an Ideal Pre-plumbed cylinder, these components are pre-installed and therefore no additional filters are required.
 - Note 4. Refer to the installation manual for anti-freeze recommendations.
 - Note 5. Install an auto-bypass if no permanent open circuit is available to allow secondary side pump overrun and normal operation.
 - Note 6. Logic Air two zone pre-plumbed arrangement is available.
 - Note 7. Refer to the installation manual for smart or ON/OFF thermostat connection.
 - Note 8. Underfloor heating circuit option. Refer to the manufacturers installation instructions for pump and bypass requirements.

This drawing is for information and guidance only. It is the heating designer/ installers responsibility to adhere to the latest relevant standards.
 Refer to Logic Air monobloc heat pump system installation and maintenance manual in conjunction with these schematic drawings.

CONNECTION POINT LIST				
TP No	DESCRIPTION	SIZE	MATERIAL	TYPE
1	HEAT PUMP FLOW	1" BSP	BRASS	BSP MALE
2	HEAT PUMP RETURN	1" BSP	BRASS	BSP MALE
3	HEAT PUMP CONDENSATE DISPOSAL	-	-	-
4	PRESSURE RELIEF VALVE (PRV)	15MM	COPPER	COPPER PIPE OUTLET
5	CYLINDER HEAT PUMP FLOW	28MM	BRASS	COMPRESSION
6	CYLINDER HEAT PUMP RETURN	28MM	BRASS	COMPRESSION
7	ZONE 1 FLOW	28MM	BRASS	COMPRESSION
8	ZONE 1 RETURN	28MM	BRASS	COMPRESSION
9	ZONE 2 FLOW	28MM	BRASS	COMPRESSION
10	ZONE 2 RETURN	28MM	BRASS	COMPRESSION

Figure 3. Logic Air + Two Zone Pre-Plumbed Cylinder with Integrated Buffer

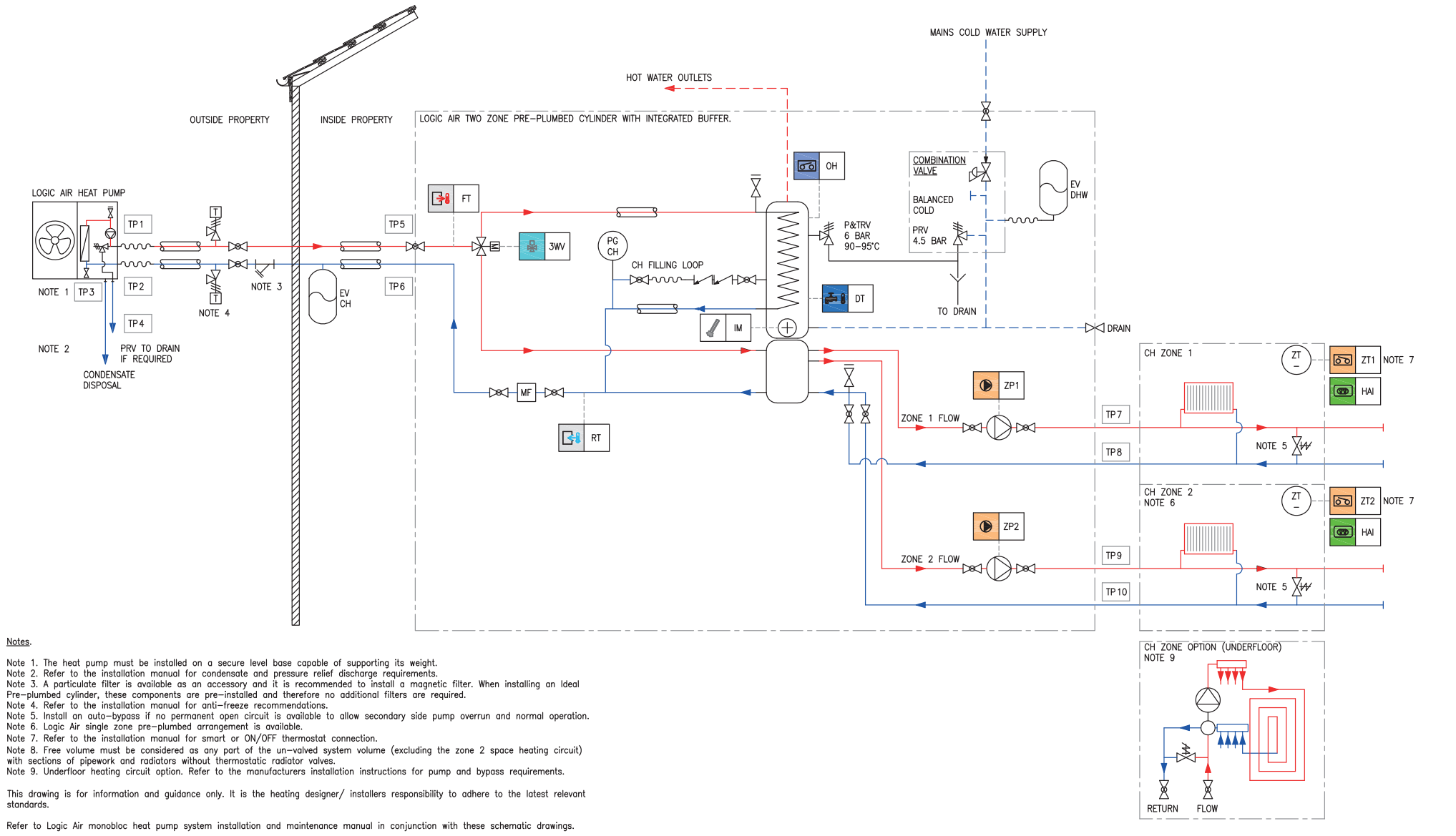

Notes.

Note 1. The heat pump must be installed on a secure level base capable of supporting its weight.
 Note 2. Refer to the installation manual for condensate and pressure relief discharge requirements.
 Note 3. A particulate filter is available as an accessory and it is recommended to install a magnetic filter. When installing an Ideal Pre-plumbed cylinder, these components are pre-installed and therefore no additional filters are required.
 Note 4. Refer to the installation manual for anti-freeze recommendations.
 Note 5. Install an auto-bypass if no permanent open circuit is available to allow secondary side pump overrun and normal operation.
 Note 6. Logic Air single zone pre-plumbed arrangement is available.
 Note 7. Refer to the installation manual for smart or ON/OFF thermostat connection.
 Note 8. Free volume must be considered as any part of the un-valved system volume (excluding the zone 2 space heating circuit) with sections of pipework and radiators without thermostatic radiator valves.
 Note 9. Underfloor heating circuit option. Refer to the manufacturers installation instructions for pump and bypass requirements.

This drawing is for information and guidance only. It is the heating designer/ installers responsibility to adhere to the latest relevant standards.

Refer to Logic Air monobloc heat pump system installation and maintenance manual in conjunction with these schematic drawings.

CONNECTION POINT LIST				
TP No	DESCRIPTION	SIZE	MATERIAL	TYPE
1	HEAT PUMP FLOW	1" BSP	BRASS	BSP MALE
2	HEAT PUMP RETURN	1" BSP	BRASS	BSP MALE
3	HEAT PUMP CONDENSATE DISPOSAL	-	-	-
4	PRESSURE RELIEF VALVE (PRV)	15MM	COPPER	COPPER PIPE OUTLET
5	CYLINDER HEAT PUMP FLOW	28MM	BRASS	COMPRESSION
6	CYLINDER HEAT PUMP RETURN	28MM	BRASS	COMPRESSION
7	ZONE 1 FLOW	28MM	BRASS	COMPRESSION
8	ZONE 1 RETURN	28MM	BRASS	COMPRESSION

Figure 4. Logic Air + Single Zone Pre-Plumbed Cylinder

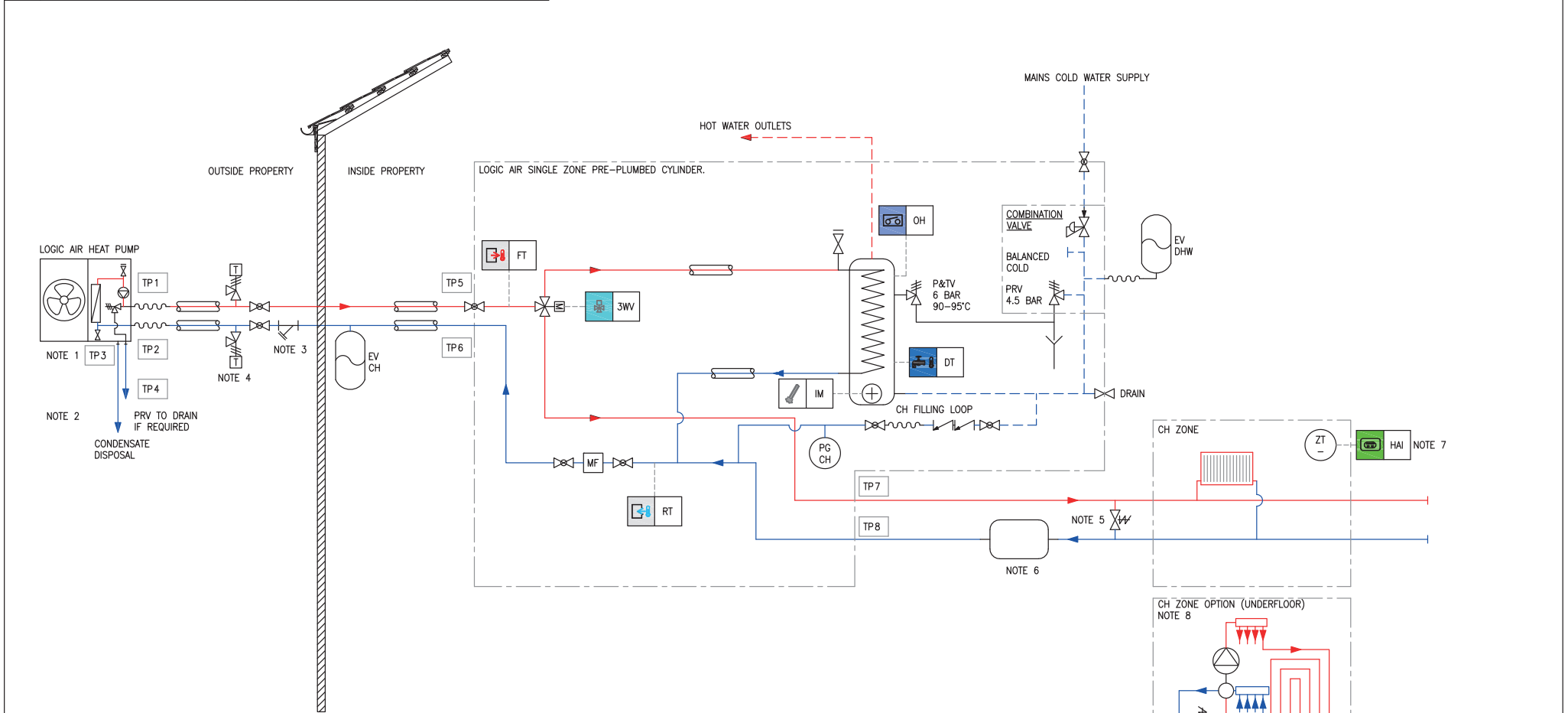

Notes.

- Note 1. The heat pump must be installed on a secure level base capable of supporting its weight.
- Note 2. Refer to the installation manual for condensate and pressure relief discharge requirements.
- Note 3. A particulate filter is available as an accessory and it is recommended to install a magnetic filter. When installing an Ideal Pre-plumbed cylinder, these components are pre-installed and therefore no additional filters are required.
- Note 4. Refer to the installation manual for anti-freeze recommendations.
- Note 5. Install an auto-bypass if no permanent open circuit is available to allow primary side pump overrun and normal operation. Ensuring minimum circulating water flow rate for heat pump defrost requirements.
- Note 6. If minimum free system water volume cannot be met, a volumiser is required.
- Note 7. Refer to the installation manual for smart thermostat connection.
- Note 8. Underfloor heating circuit option. Refer to the manufacturers installation instructions for pump and bypass requirements.

This drawing is for information and guidance only. It is the heating designer/installers responsibility to adhere to the latest relevant standards.

Refer to Logic Air monobloc heat pump system installation and maintenance manual in conjunction with these schematic drawings.

CONNECTION POINT LIST				
TP No	DESCRIPTION	SIZE	MATERIAL	TYPE
1	HEAT PUMP FLOW	1" BSP	BRASS	BSP MALE
2	HEAT PUMP RETURN	1" BSP	BRASS	BSP MALE
3	HEAT PUMP CONDENSATE DISPOSAL	-	-	-
4	PRESSURE RELIEF VALVE (PRV)	15MM	COPPER	COPPER PIPE OUTLET
5	HEAT PUMP FLOW	28MM	BRASS	COMPRESSION
6	HEAT PUMP RETURN	28MM	BRASS	COMPRESSION
7	ZONE FLOW	28MM	BRASS	COMPRESSION
8	ZONE RETURN	28MM	BRASS	COMPRESSION

Figure 5. Logic Air + Standard Non Pre-Plumbed Heat Pump Cylinder + Buffer with Single Zone

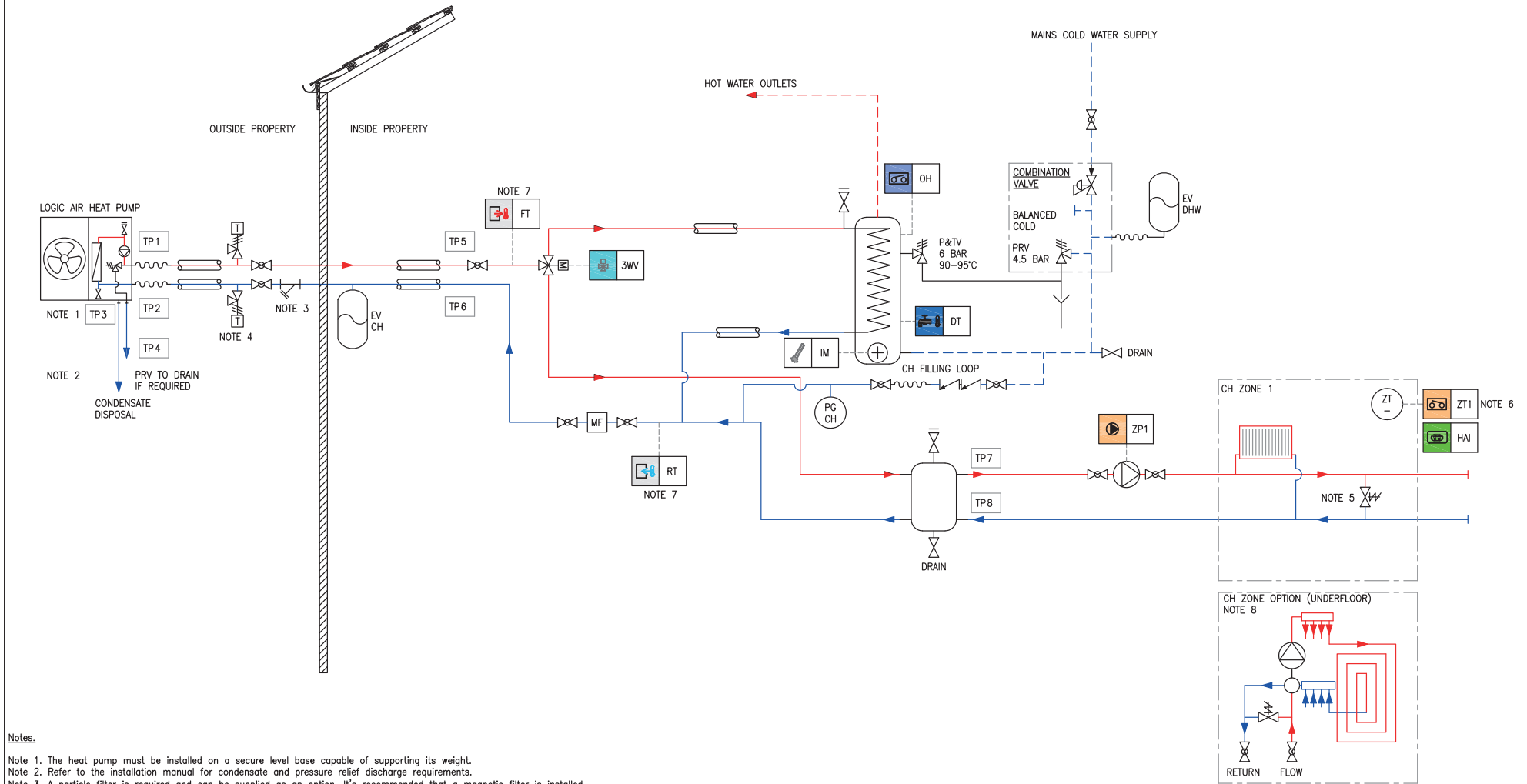

Notes.

- Note 1. The heat pump must be installed on a secure level base capable of supporting its weight.
- Note 2. Refer to the installation manual for condensate and pressure relief discharge requirements.
- Note 3. A particle filter is required and can be supplied as an option. It's recommended that a magnetic filter is installed.
- Note 4. Refer to the installation manual for anti-freeze recommendations.
- Note 5. Install an auto-bypass if no permanent open circuit is available to allow secondary side pump overrun and normal operation.
- Note 6. Refer to the installation manual for smart or ON/OFF thermostatic connection.
- Note 7. Flow and return pipe clip-on sensors must be installed on the 28mm copper pipe work.
- Note 8. Underfloor heating circuit option. Refer to the manufacturers installation instructions for pump and bypass requirements.

This drawing is for information and guidance only. It is the heating designer/installers responsibility to adhere to the latest relevant standards.

Refer to Logic Air monobloc heatpump system installation and maintenance manual in conjunction with these schematic drawings.

CONNECTION POINT LIST				
TP No	DESCRIPTION	SIZE	MATERIAL	TYPE
1	HEAT PUMP FLOW	1" BSP	BRASS	BSP MALE
2	HEAT PUMP RETURN	1" BSP	BRASS	BSP MALE
3	HEAT PUMP CONDENSATE DISPOSAL	-	-	-
4	PRESSURE RELIEF VALVE (PRV)	15MM	COPPER	COPPER PIPE OUTLET
5	HEAT PUMP FLOW	28MM	BRASS	COMPRESSION
6	HEAT PUMP RETURN	28MM	BRASS	COMPRESSION
7	ZONE FLOWS	28MM	BRASS	COMPRESSION
8	ZONE RETURNS	28MM	BRASS	COMPRESSION

Figure 6. Logic Air + Standard Non Pre-Plumbed Heat Pump Cylinder + Buffer with Two Zones

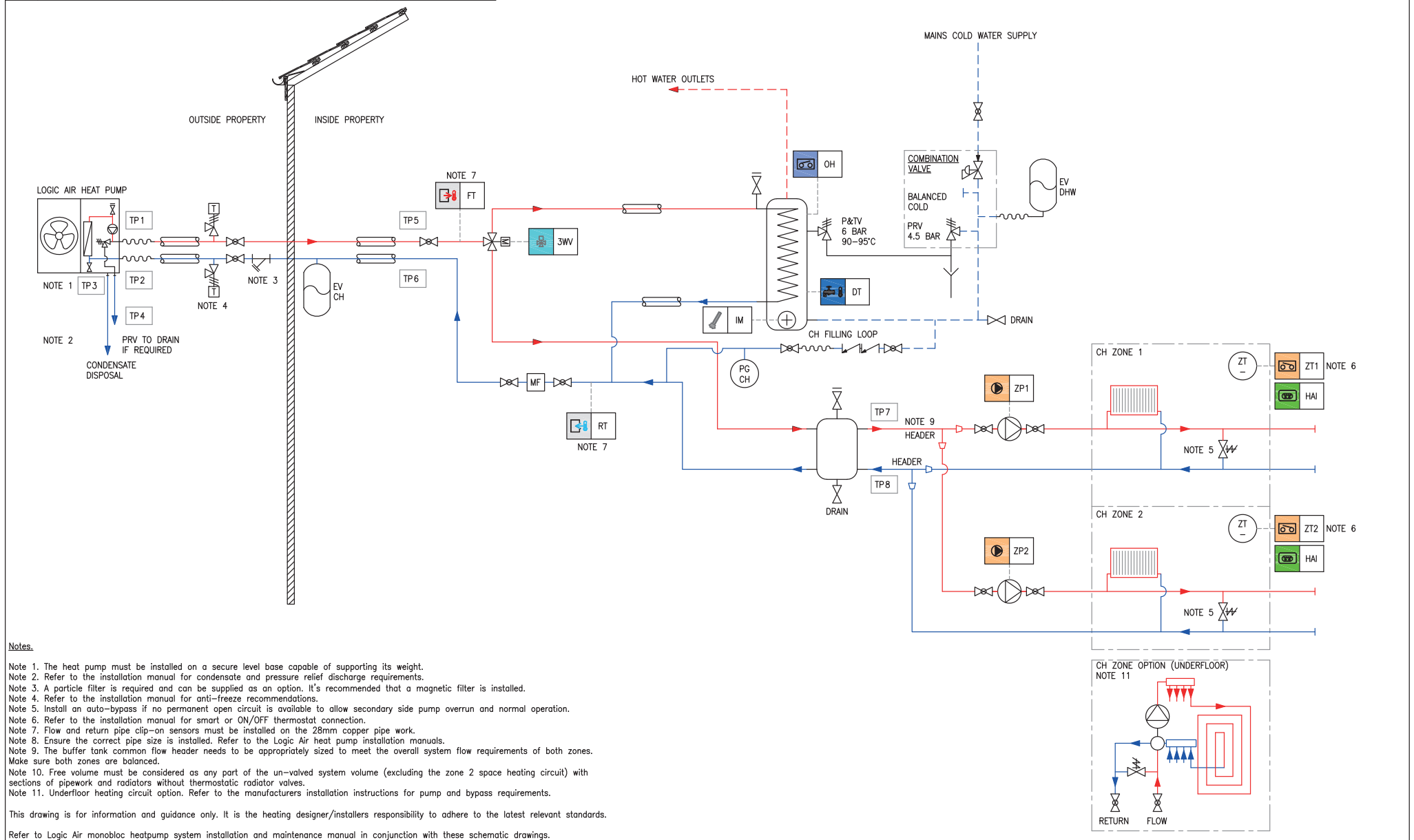

Notes.

- Note 1. The heat pump must be installed on a secure level base capable of supporting its weight.
 - Note 2. Refer to the installation manual for condensate and pressure relief discharge requirements.
 - Note 3. A particle filter is required and can be supplied as an option. It's recommended that a magnetic filter is installed.
 - Note 4. Refer to the installation manual for anti-freeze recommendations.
 - Note 5. Install an auto-bypass if no permanent open circuit is available to allow secondary side pump overrun and normal operation.
 - Note 6. Refer to the installation manual for smart or ON/OFF thermostat connection.
 - Note 7. Flow and return pipe clip-on sensors must be installed on the 28mm copper pipe work.
 - Note 8. Ensure the correct pipe size is installed. Refer to the Logic Air heat pump installation manuals.
 - Note 9. The buffer tank common flow header needs to be appropriately sized to meet the overall system flow requirements of both zones. Make sure both zones are balanced.
 - Note 10. Free volume must be considered as any part of the un-valved system volume (excluding the zone 2 space heating circuit) with sections of pipework and radiators without thermostatic radiator valves.
 - Note 11. Underfloor heating circuit option. Refer to the manufacturers installation instructions for pump and bypass requirements.
- This drawing is for information and guidance only. It is the heating designer/installers responsibility to adhere to the latest relevant standards.
Refer to Logic Air monobloc heatpump system installation and maintenance manual in conjunction with these schematic drawings.

CONNECTION POINT LIST				
TP No	DESCRIPTION	SIZE	MATERIAL	TYPE
1	HEAT PUMP FLOW	1" BSP	BRASS	BSP MALE
2	HEAT PUMP RETURN	1" BSP	BRASS	BSP MALE
3	HEAT PUMP CONDENSATE DISPOSAL	-	-	-
4	PRESSURE RELIEF VALVE (PRV)	15MM	COPPER	COPPER PIPE OUTLET
5	HEAT PUMP FLOW	28MM	BRASS	COMPRESSION
6	HEAT PUMP RETURN	28MM	BRASS	COMPRESSION
7	ZONE FLOWS	28MM	BRASS	COMPRESSION
8	ZONE RETURNS	28MM	BRASS	COMPRESSION

Figure 7. Logic Air + Single Zone Pre-Plumbed Cylinder + External Buffer with Two Zones

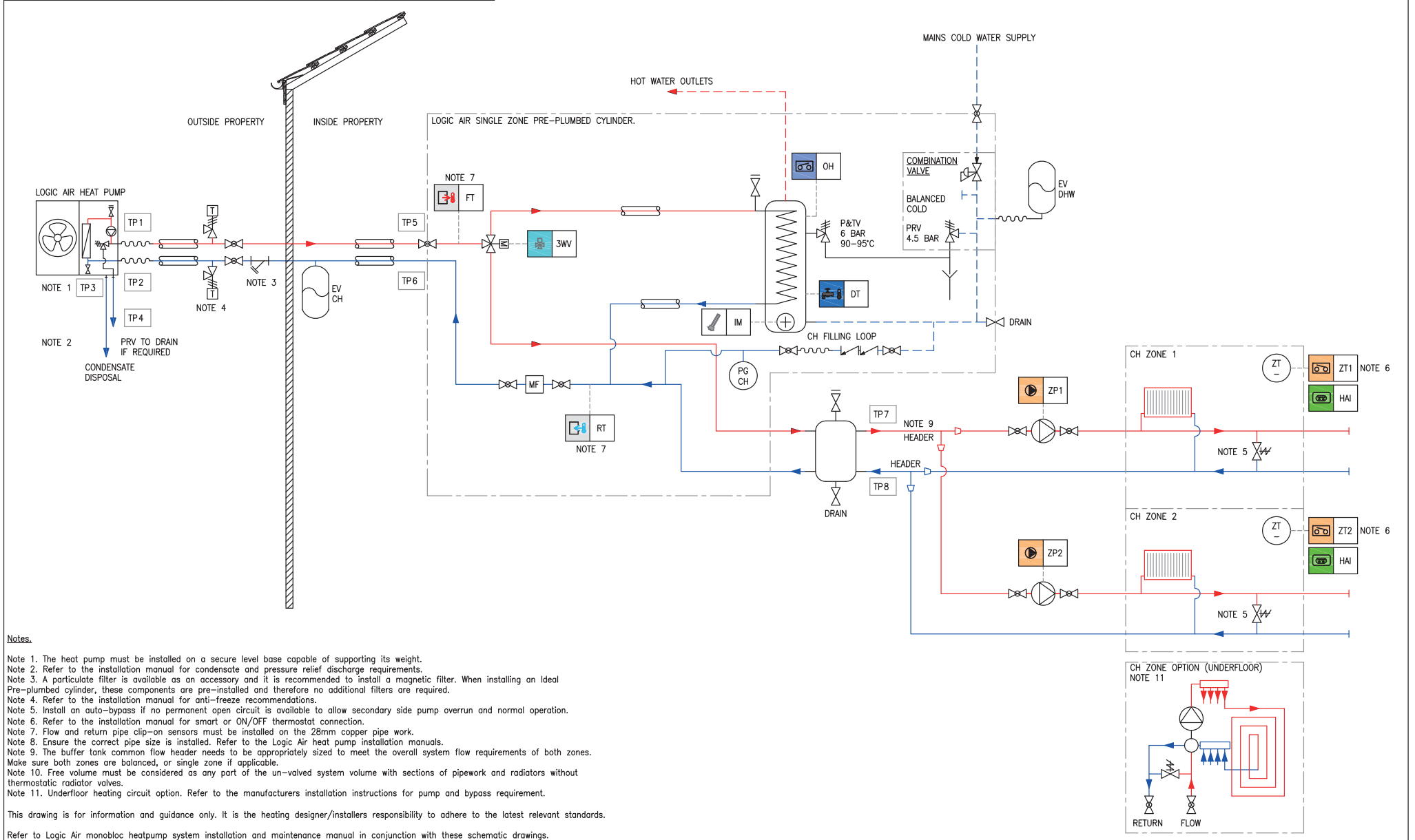

CONNECTION POINT LIST				
TP No	DESCRIPTION	SIZE	MATERIAL	TYPE
1	HEAT PUMP FLOW	1" BSP	BRASS	BSP MALE
2	HEAT PUMP RETURN	1" BSP	BRASS	BSP MALE
3	HEAT PUMP CONDENSATE DISPOSAL	-	-	-
4	PRESSURE RELIEF VALVE (PRV)	15MM	COPPER	COPPER PIPE OUTLET
5	CYLINDER HEAT PUMP FLOW	28MM	BRASS	COMPRESSION
6	CYLINDER HEAT PUMP RETURN	28MM	BRASS	COMPRESSION
7	ZONE 1 FLOW	28MM	BRASS	COMPRESSION
8	ZONE 1 RETURN	28MM	BRASS	COMPRESSION
9	ZONE 2 FLOW	28MM	BRASS	COMPRESSION
10	ZONE 2 RETURN	28MM	BRASS	COMPRESSION

Figure 8. Logic Air + Two Zone Pre-Plumbed Cylinder with Integrated Low Loss Header

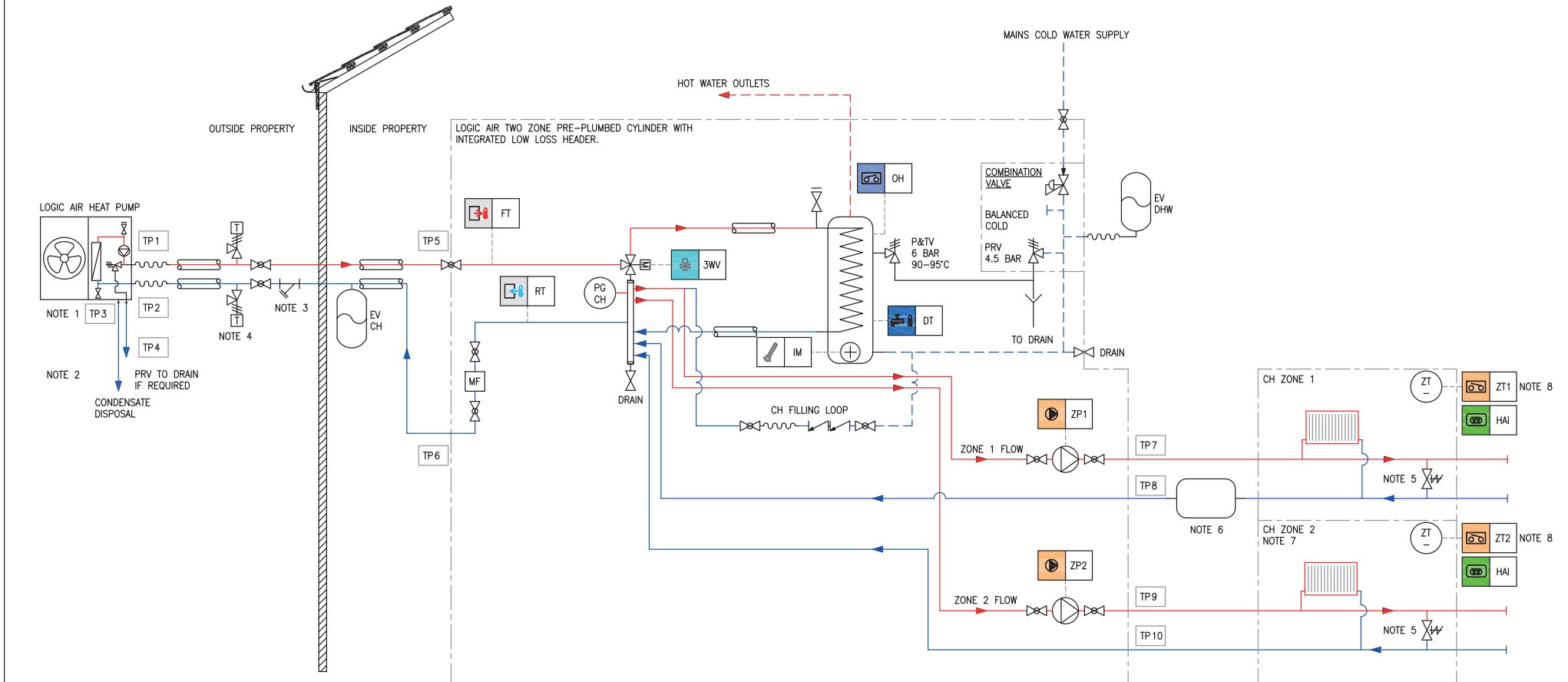

Notes.

- Note 1. The heat pump must be installed on a secure level base capable of supporting its weight.
- Note 2. Refer to the installation manual for condensate and pressure relief discharge requirements.
- Note 3. A particulate filter is available as an accessory and it is recommended to install a magnetic filter. When installing an Ideal Pre-plumbed cylinder, these components are pre-installed and therefore no additional filters are required.
- Note 4. Refer to the installation manual for anti-freeze recommendations.
- Note 5. Install an auto-bypass if no permanent open circuit is available to allow secondary side pump overrun and normal operation.
- Note 6. If minimum free system water volume cannot be met, a volumiser is required.
- Note 7. Logic Air single zone pre-plumbed arrangement is available.
- Note 8. Refer to the installation manual for smart or ON/OFF thermostat connection.
- Note 9. Free volume must be considered as any part of the un-valved system volume (excluding the zone 2 space heating circuit) with sections of pipework and radiators without thermostatic radiator valves.
- Note 10. Underfloor heating circuit option. Refer to the manufacturers installation instructions for pump and bypass requirements.

This drawing is for information and guidance only. It is the heating designer/installers responsibility to adhere to the latest relevant standards.

Refer to Logic Air monobloc heat pump system installation and maintenance manual in conjunction with these schematic drawings.

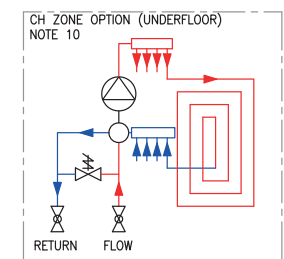

CONNECTION POINT LIST				
TP No	DESCRIPTION	SIZE	MATERIAL	TYPE
1	HEAT PUMP FLOW	1" BSP	BRASS	BSP MALE
2	HEAT PUMP RETURN	1" BSP	BRASS	BSP MALE
3	HEAT PUMP CONDENSATE DISPOSAL	-	-	-
4	PRESSURE RELIEF VALVE (PRV)	15MM	COPPER	COPPER PIPE OUTLET
5	CYLINDER HEAT PUMP FLOW	28MM	BRASS	COMPRESSION
6	CYLINDER HEAT PUMP RETURN	28MM	BRASS	COMPRESSION
7	ZONE 1 FLOW	28MM	BRASS	COMPRESSION
8	ZONE 1 RETURN	28MM	BRASS	COMPRESSION
9	ZONE 2 FLOW	28MM	BRASS	COMPRESSION
10	ZONE 2 RETURN	28MM	BRASS </td <td>COMPRESSION</td>	COMPRESSION

Figure 9. Logic Air Three Zone + Two Zone Pre-Plumbed Cylinder with Integrated Buffer (Note, requires additional 3rd party electrical wiring for a 3rd zone).

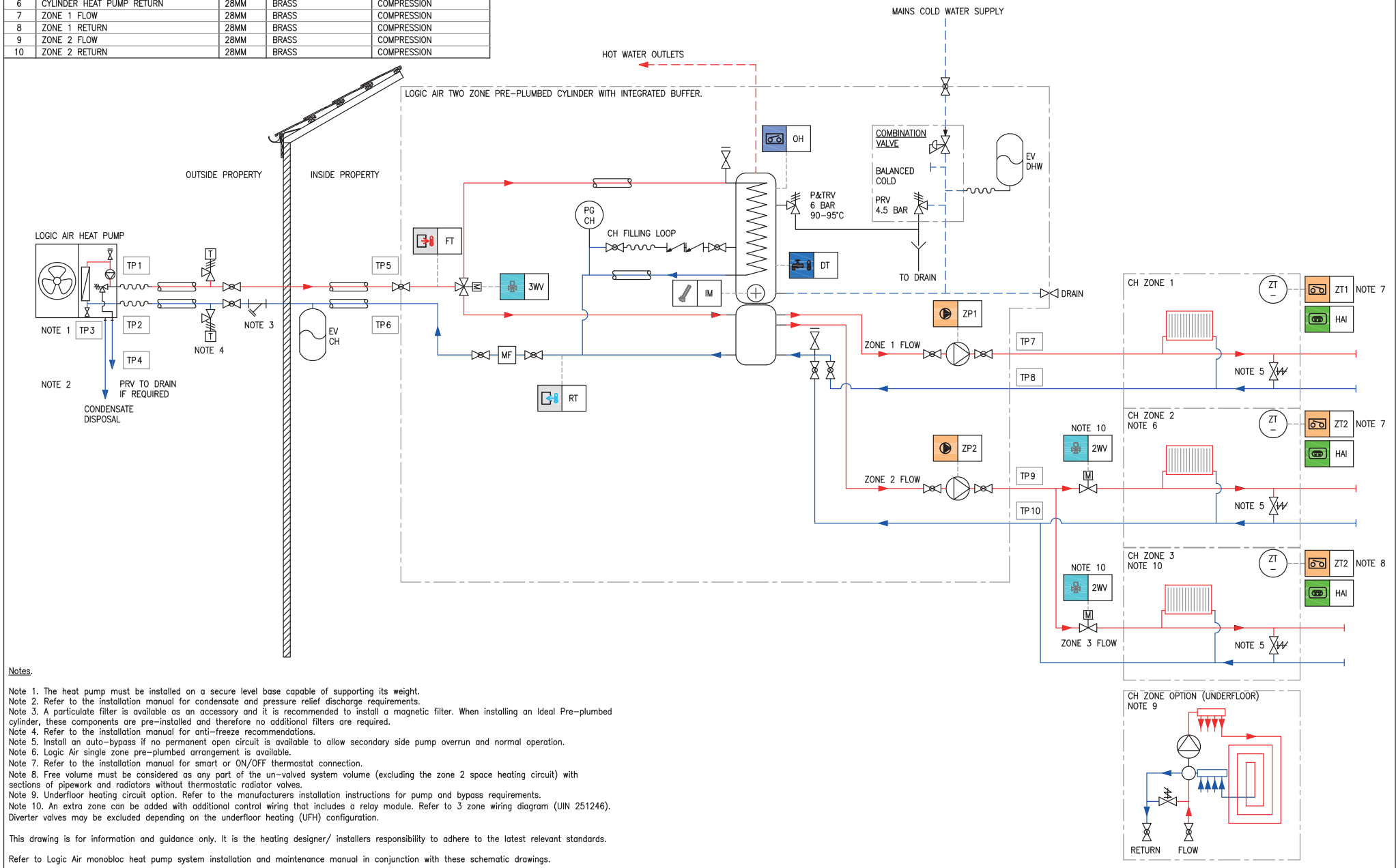

Notes.

Note 1. The heat pump must be installed on a secure level base capable of supporting its weight.

Note 2. Refer to the installation manual for condensate and pressure relief discharge requirements.

Note 3. A particulate filter is available as an accessory and it is recommended to install a magnetic filter. When installing an Ideal Pre-plumbed cylinder, these components are pre-installed and therefore no additional filters are required.

Note 4. Refer to the installation manual for anti-freeze recommendations.

Note 5. Install an auto-bypass if no permanent open circuit is available to allow secondary side pump overrun and normal operation.

Note 6. Logic Air single zone pre-plumbed arrangement is available.

Note 7. Refer to the installation manual for smart or ON/OFF thermostat connection.

Note 8. Free volume must be considered as any part of the un-valved system volume (excluding the zone 2 space heating circuit) with sections of pipework and radiators without thermostatic radiator valves.

Note 9. Underfloor heating circuit option. Refer to the manufacturers installation instructions for pump and bypass requirements.

Note 10. An extra zone can be added with additional control wiring that includes a relay module. Refer to 3 zone wiring diagram (UIN 251246). Diverter valves may be excluded depending on the underfloor heating (UFH) configuration.

This drawing is for information and guidance only. It is the heating designer/ installers responsibility to adhere to the latest relevant standards.

Refer to Logic Air monobloc heat pump system installation and maintenance manual in conjunction with these schematic drawings.

CONNECTION POINT LIST				
TP No	DESCRIPTION	SIZE	MATERIAL	TYPE
1	HEAT PUMP FLOW	1" BSP	BRASS	BSP MALE
2	HEAT PUMP RETURN	1" BSP	BRASS	BSP MALE
3	HEAT PUMP CONDENSATE DISPOSAL	-	-	-
4	PRESSURE RELIEF VALVE (PRV)	15MM	COPPER	COPPER PIPE OUTLET
5	CYLINDER HEAT PUMP FLOW	28MM	BRASS	COMPRESSION
6	CYLINDER HEAT PUMP RETURN	28MM	BRASS	COMPRESSION
7	ZONE 1 FLOW	28MM	BRASS	COMPRESSION
8	ZONE 1 RETURN	28MM	BRASS	COMPRESSION
9	ZONE 2 FLOW	28MM	BRASS	COMPRESSION
10	ZONE 2 RETURN	28MM	BRASS	COMPRESSION

Figure 10. Logic Air Three Zone + Two Zone Pre-Plumbed Cylinder with Integrated Low Loss Header (Note, requires additional 3rd party electrical wiring for a 3rd zone).

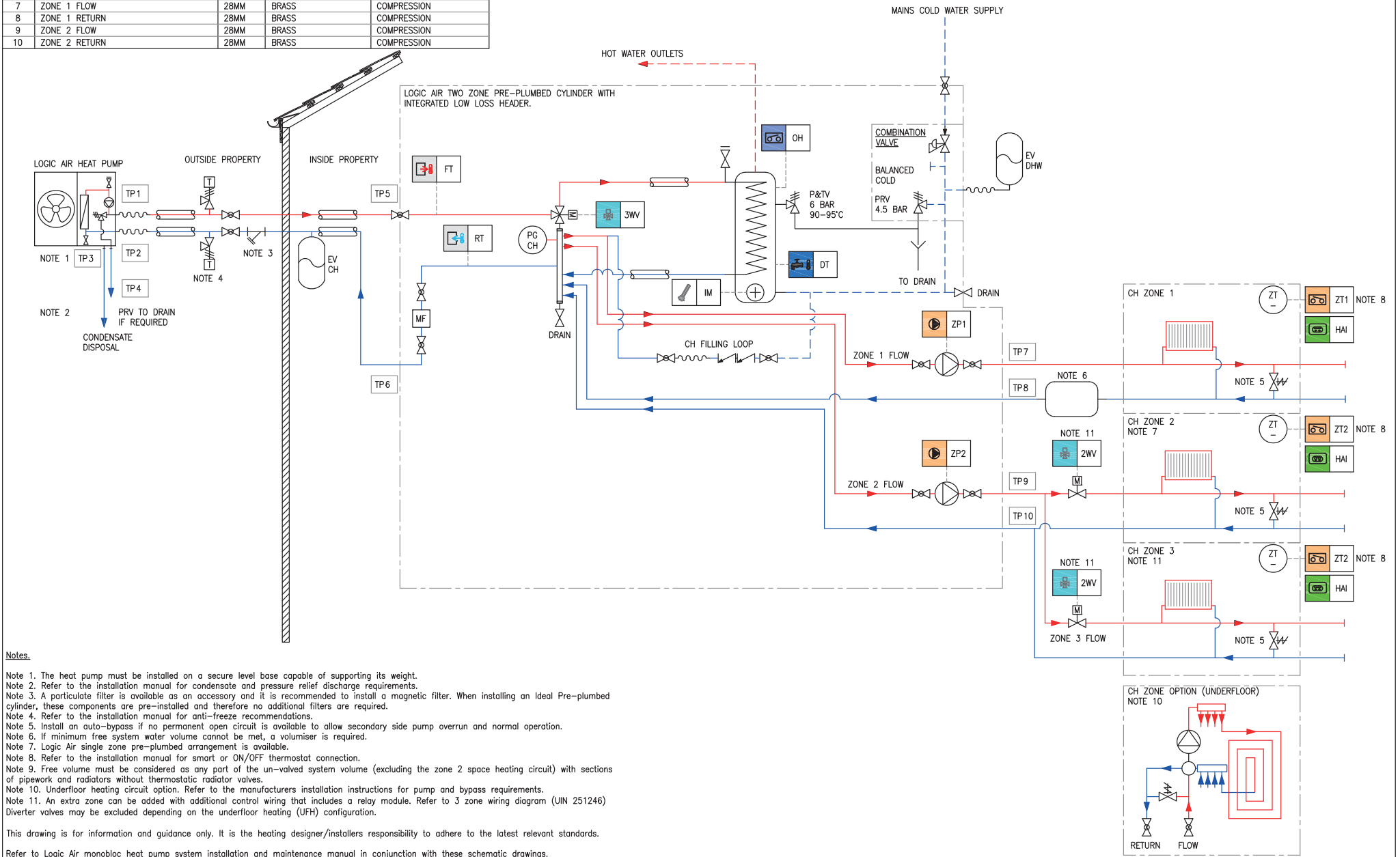

Notes.

- Note 1. The heat pump must be installed on a secure level base capable of supporting its weight.
- Note 2. Refer to the installation manual for condensate and pressure relief discharge requirements.
- Note 3. A particulate filter is available as an accessory and it is recommended to install a magnetic filter. When installing an Ideal Pre-plumbed cylinder, these components are pre-installed and therefore no additional filters are required.
- Note 4. Refer to the installation manual for anti-freeze recommendations.
- Note 5. Install an auto-bypass if no permanent open circuit is available to allow secondary side pump overrun and normal operation.
- Note 6. If minimum free system water volume cannot be met, a volumiser is required.
- Note 7. Logic Air single zone pre-plumbed arrangement is available.
- Note 8. Refer to the installation manual for smart or ON/OFF thermostat connection.
- Note 9. Free volume must be considered as any part of the un-valved system volume (excluding the zone 2 space heating circuit) with sections of pipework and radiators without thermostatic radiator valves.
- Note 10. Underfloor heating circuit option. Refer to the manufacturers installation instructions for pump and bypass requirements.
- Note 11. An extra zone can be added with additional control wiring that includes a relay module. Refer to 3 zone wiring diagram (UIN 251246) Diverter valves may be excluded depending on the underfloor heating (UFH) configuration.

This drawing is for information and guidance only. It is the heating designer/installers responsibility to adhere to the latest relevant standards.

Refer to Logic Air monobloc heat pump system installation and maintenance manual in conjunction with these schematic drawings.

CONNECTION POINT LIST				
TP No	DESCRIPTION	SIZE	MATERIAL	TYPE
1	HEAT PUMP FLOW	1" BSP	BRASS	BSP MALE
2	HEAT PUMP RETURN	1" BSP	BRASS	BSP MALE
3	HEAT PUMP CONDENSATE DISPOSAL	-	-	-
4	PRESSURE RELIEF VALVE (PRV)	15MM	COPPER	COPPER PIPE OUTLET

Figure 11. Logic Air + Decoupling Buffer for Heating Only with Two Zones

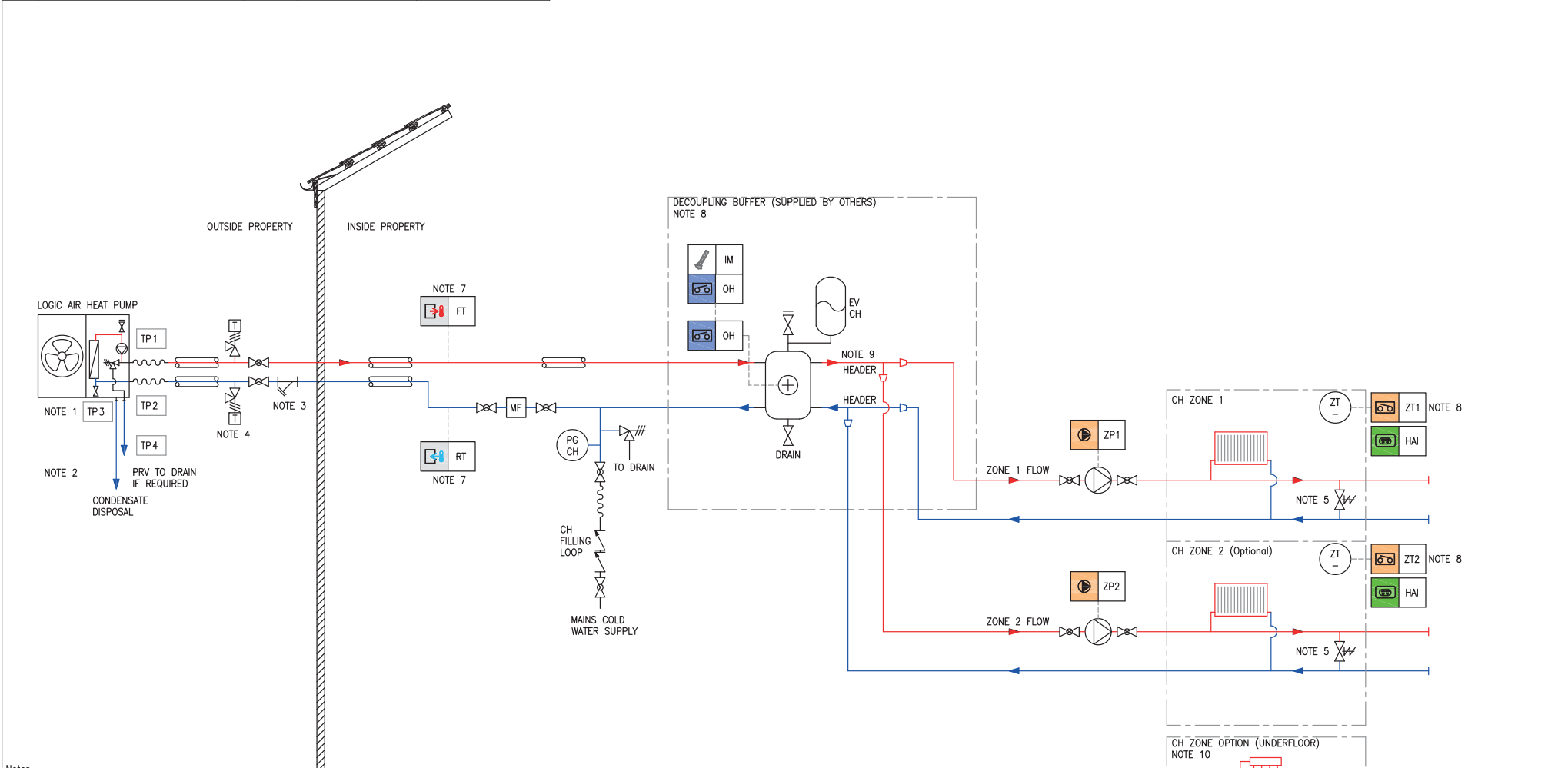

Notes.

- Note 1. The heat pump must be installed on a secure level base capable of supporting its weight.
- Note 2. Refer to the installation manual for condensate and pressure relief discharge requirements.
- Note 3. A particulate filter is required and can be supplied as an option. A magnetic filter is recommended.
- Note 4. Refer to the installation manual for anti-freeze recommendations.
- Note 5. Install an auto-bypass if no permanent open circuit is available to allow secondary side pump overrun and normal operation.
- Note 6. Refer to the installation manual for smart or ON/OFF thermostat connection.
- Note 7. Flow and return pipe clip-on sensors must be installed on the 28mm copper pipe work.
- Note 8. Decoupling buffer vessel complete with heater and safety accessories. It is the installers responsibility to ensure all relevant regulations and buffer tank manufactures installation requirements are met. Make sure a pressure relief valve is always open to the decoupling buffer vessel without means of isolation. Make sure the immersion heater control thermostat is set to less than or equal to 55°C.
- Note 9. The buffer tank common flow header needs to be appropriately sized to meet the overall system flow requirements of both zones. Make sure both zones are balanced. This can be arranged as a single zone if required.
- Note 10. Underfloor heating circuit option. Refer to the manufacturers installation instructions for pump and bypass requirements.

This drawing is for information and guidance only. It is the heating designer/ installers responsibility to adhere to the latest relevant standards.

Refer to Logic Air monobloc heatpump system installation and maintenance manual in conjunction with these schematic drawings.

CONNECTION POINT LIST				
TP No	DESCRIPTION	SIZE	MATERIAL	TYPE
1	HEAT PUMP FLOW	1" BSP	BRASS	BSP MALE
2	HEAT PUMP RETURN	1" BSP	BRASS	BSP MALE
3	HEAT PUMP CONDENSATE DISPOSAL	-	-	-
4	PRESSURE RELIEF VALVE (PRV)	15MM	COPPER	COPPER PIPE OUTLET

Figure 12. Logic Air + Combi Boiler + Single Zone without Buffer (Bivalent System)

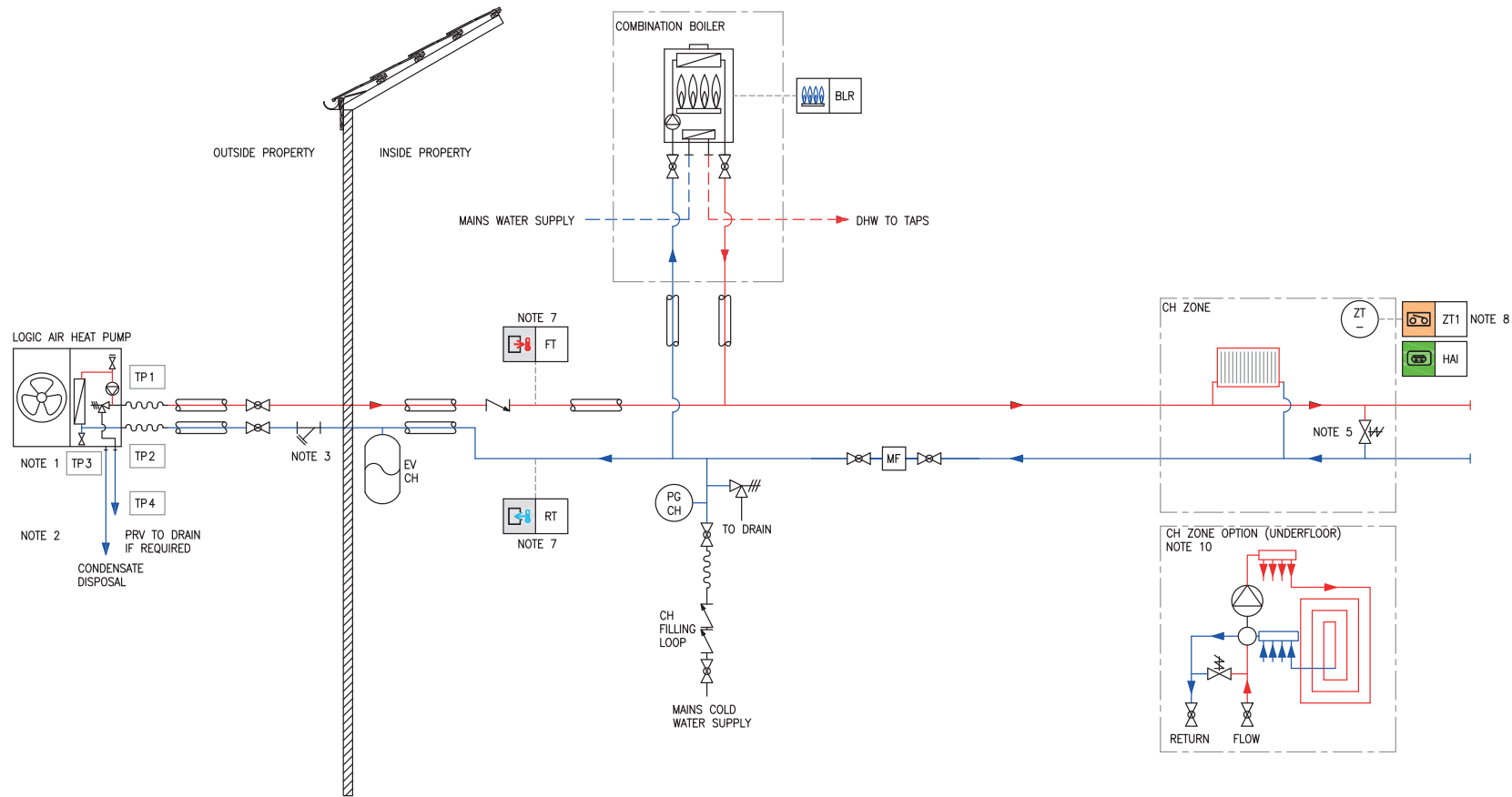

Notes.

- Note 1. The heat pump must be installed on a secure level base capable of supporting its weight.
- Note 2. Refer to the installation manual for condensate and pressure relief discharge requirements.
- Note 3. A particulate filter is required and can be supplied as an option. A magnetic filter is recommended.
- Note 4. Glycol is required for antifreeze protection on all hybrid systems.
- Note 5. Install an auto-bypass if no permanent open circuit is available to allow secondary side pump overrun and normal operation.
- Note 6. Boiler flow temperature should not be set above 50°C. A non-return valve may be required on the boiler flow pipe depending on the boiler characteristics. A non-return valve is not required for ideal combination boilers.
- Note 7. Flow and return pipe clip-on sensors must be installed on the 28mm copper pipe work.
- Note 8. Refer to the installation manual for smart or ON/OFF thermostat connection.
- Note 9. Ensure the correct pipe size is installed. Refer to the Logic Air heat pump and boiler installation manuals.
- Note 10. Underfloor heating circuit option. Refer to the manufacturers installation instructions for pump and bypass requirements.

This drawing is for information and guidance only. It is the heating designer/ installers responsibility to adhere to the latest relevant standards.

Refer to Logic Air monobloc heatpump system installation and maintenance manual in conjunction with these schematic drawings.

CONNECTION POINT LIST				
TP No	DESCRIPTION	SIZE	MATERIAL	TYPE
1	HEAT PUMP FLOW	1" BSP	BRASS	BSP MALE
2	HEAT PUMP RETURN	1" BSP	BRASS	BSP MALE
3	HEAT PUMP CONDENSATE DISPOSAL	-	-	-
4	PRESSURE RELIEF VALVE (PRV)	15MM	COPPER	COPPER PIPE OUTLET

Figure 13. Logic Air + Combi Boiler + Buffer + Single Zone (Bivalent System)

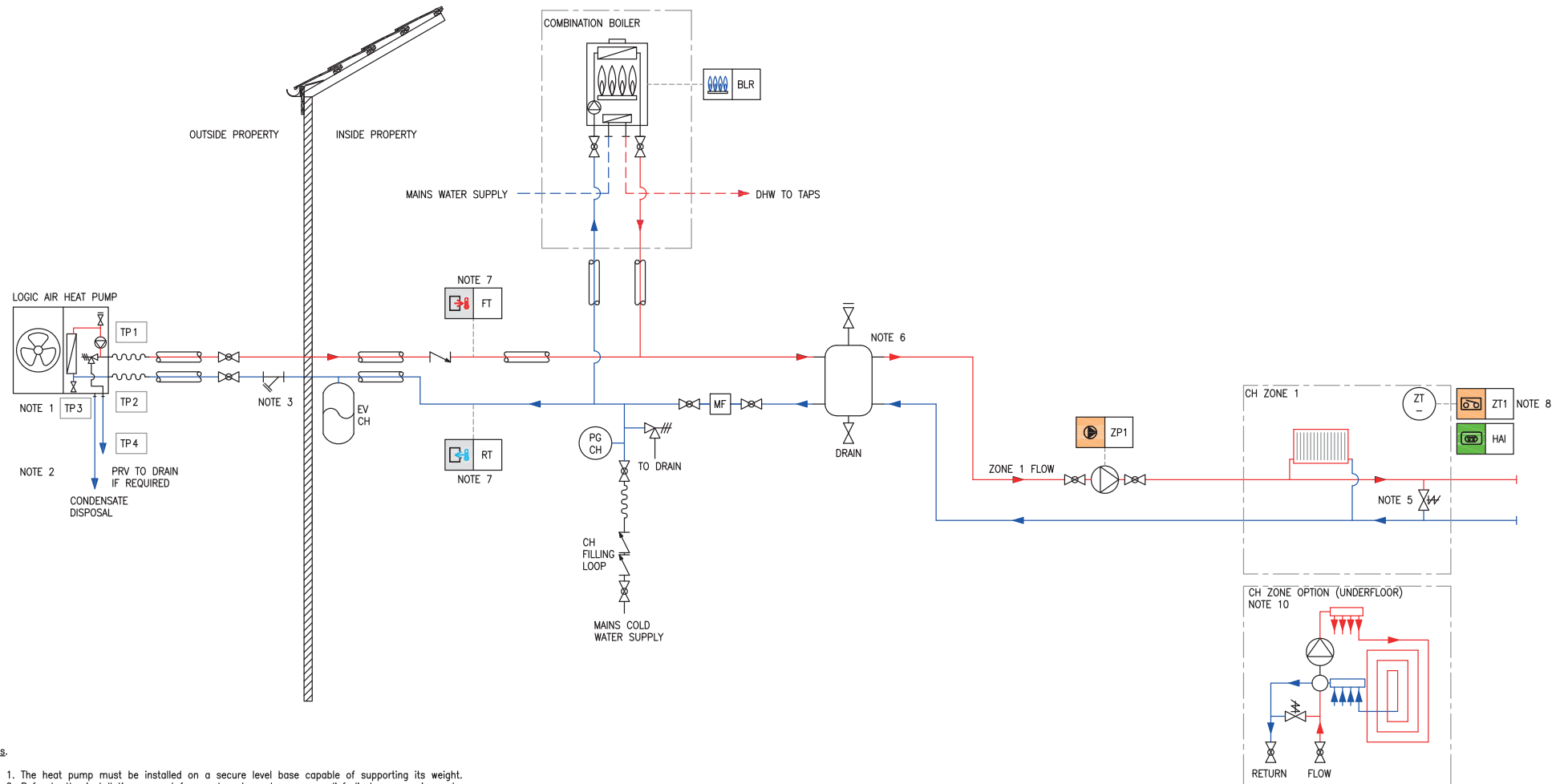

Notes.

- Note 1. The heat pump must be installed on a secure level base capable of supporting its weight.
- Note 2. Refer to the installation manual for condensate and pressure relief discharge requirements.
- Note 3. A particulate filter is required and can be supplied as an option. A magnetic filter is recommended.
- Note 4. Glycol is required for antifreeze protection on all hybrid systems.
- Note 5. Install an auto-bypass if no permanent open circuit is available to allow secondary side pump overrun and normal operation.
- Note 6. Boiler flow temperature should not be set above 50°C. A non-return valve may be required on the boiler flow pipe depending on the boiler characteristics. A non-return valve is not required for Ideal combination boilers.
- Note 7. Flow and return pipe clip-on sensors must be installed on the 28mm copper pipe work.
- Note 8. Refer to the installation manual for smart or ON/OFF thermostat connection.
- Note 9. Ensure the correct pipe size is installed. Refer to the Logic Air heat pump and boiler installation manuals.
- Note 10. Underfloor heating circuit option. Refer to the manufacturers installation instructions for pump and bypass requirements.

This drawing is for information and guidance only. It is the heating designer/ installers responsibility to adhere to the latest relevant standards.

Refer to Logic Air monobloc heatpump system installation and maintenance manual in conjunction with these schematic drawings.

CONNECTION POINT LIST				
TP No	DESCRIPTION	SIZE	MATERIAL	TYPE
1	HEAT PUMP FLOW	1" BSP	BRASS	BSP MALE
2	HEAT PUMP RETURN	1" BSP	BRASS	BSP MALE
3	HEAT PUMP CONDENSATE DISPOSAL	-	-	-
4	PRESSURE RELIEF VALVE (PRV)	15MM	COPPER	COPPER PIPE OUTLET

Figure 14. Logic Air + Combi Boiler + Buffer + Two Zones (Bivalent System)

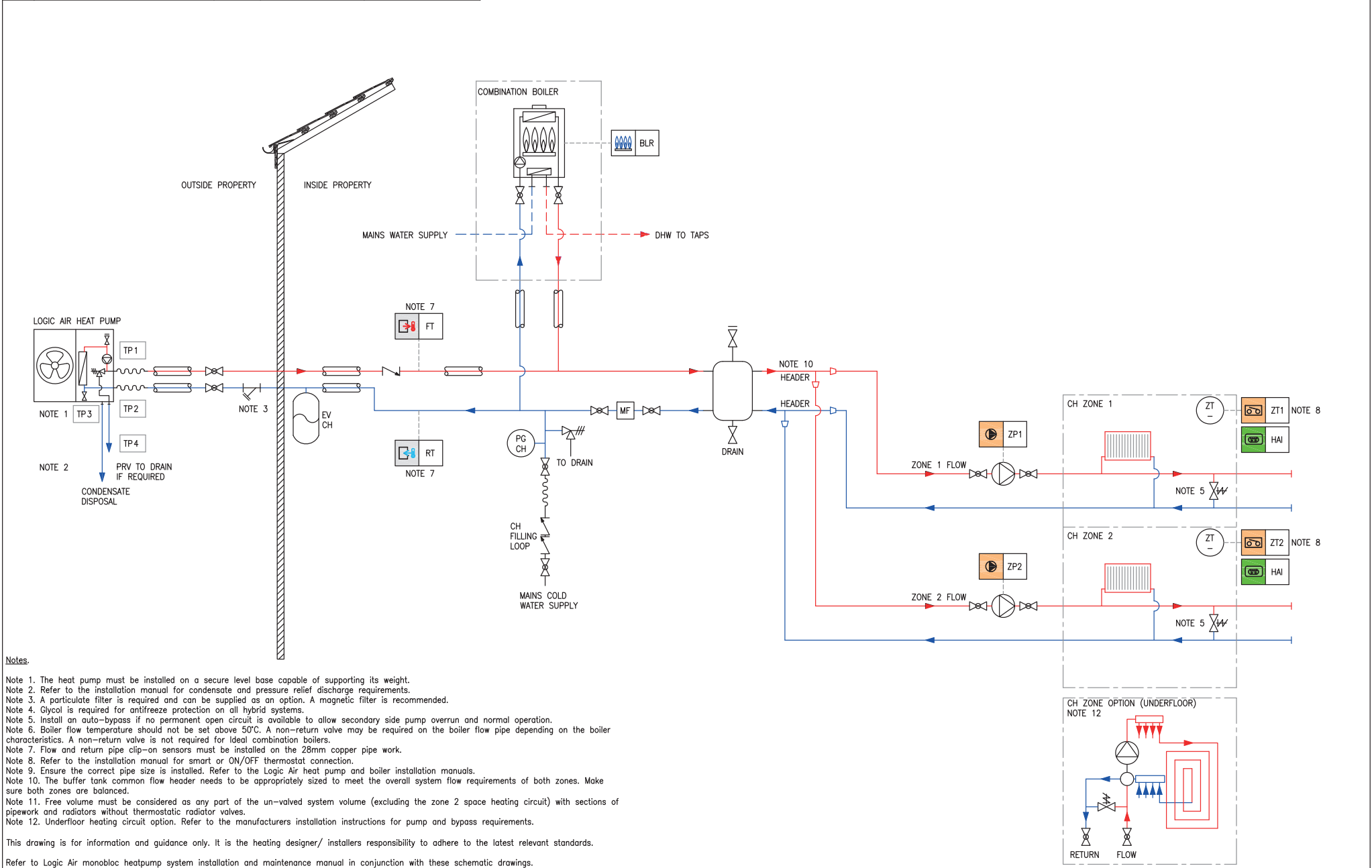

CONNECTION POINT LIST				
TP No	DESCRIPTION	SIZE	MATERIAL	TYPE
1	HEAT PUMP FLOW	1" BSP	BRASS	BSP MALE
2	HEAT PUMP RETURN	1" BSP	BRASS	BSP MALE
3	HEAT PUMP CONDENSATE DISPOSAL	-	-	-
4	PRESSURE RELIEF VALVE (PRV)	15MM	COPPER	COPPER PIPE OUTLET

Figure 15. Logic Air + Heating Only + System Boiler + Buffer with Two Zones (Bivalent System)

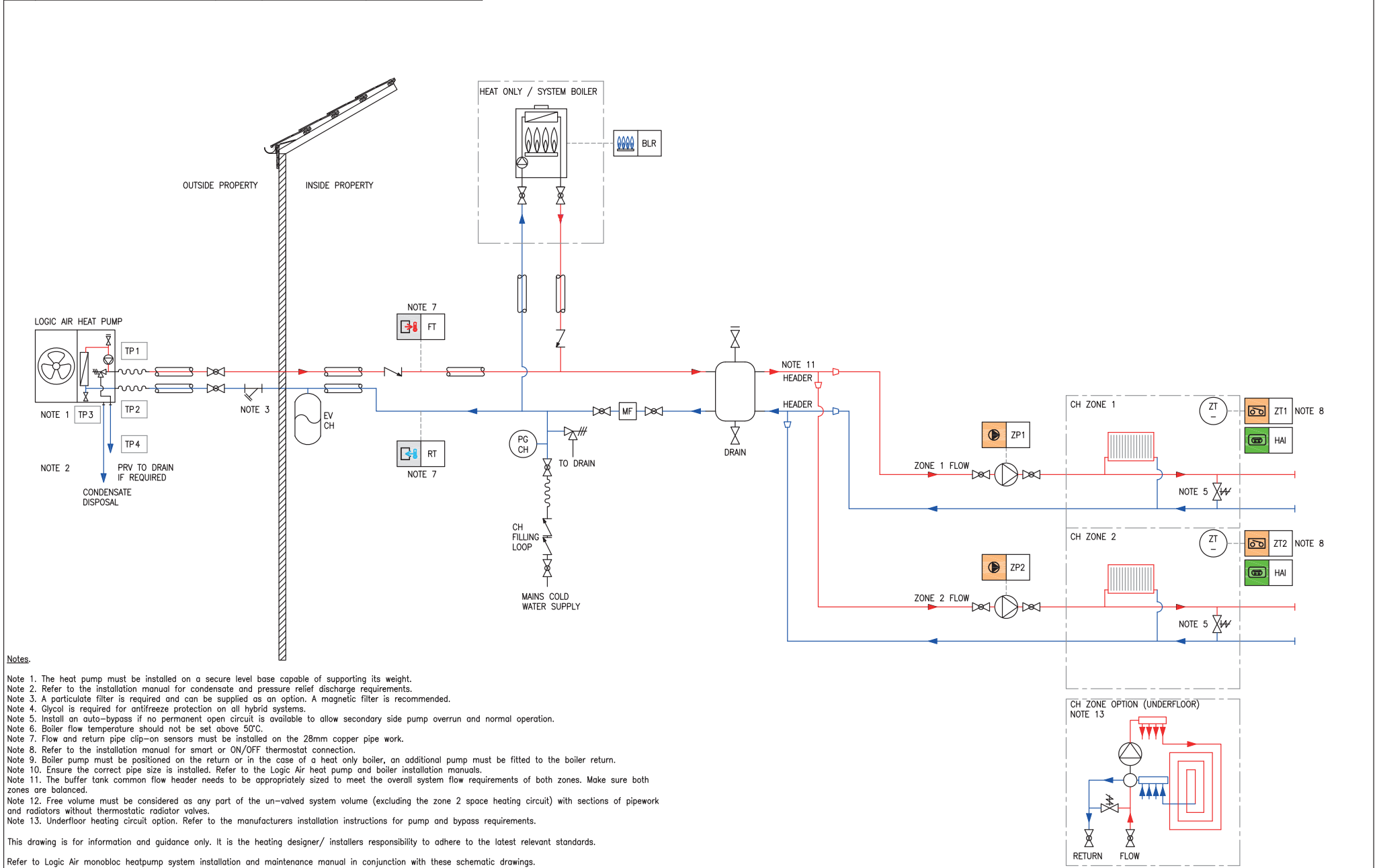

CONNECTION POINT LIST				
TP No	DESCRIPTION	SIZE	MATERIAL	TYPE
1	HEAT PUMP FLOW	1" BSP	BRASS	BSP MALE
2	HEAT PUMP RETURN	1" BSP	BRASS	BSP MALE
3	HEAT PUMP CONDENSATE DISPOSAL	-	-	-
4	PRESSURE RELIEF VALVE (PRV)	15MM	COPPER	COPPER PIPE OUTLET

Figure 16. Logic Air + Heat Only Boiler Backup + Single Zone

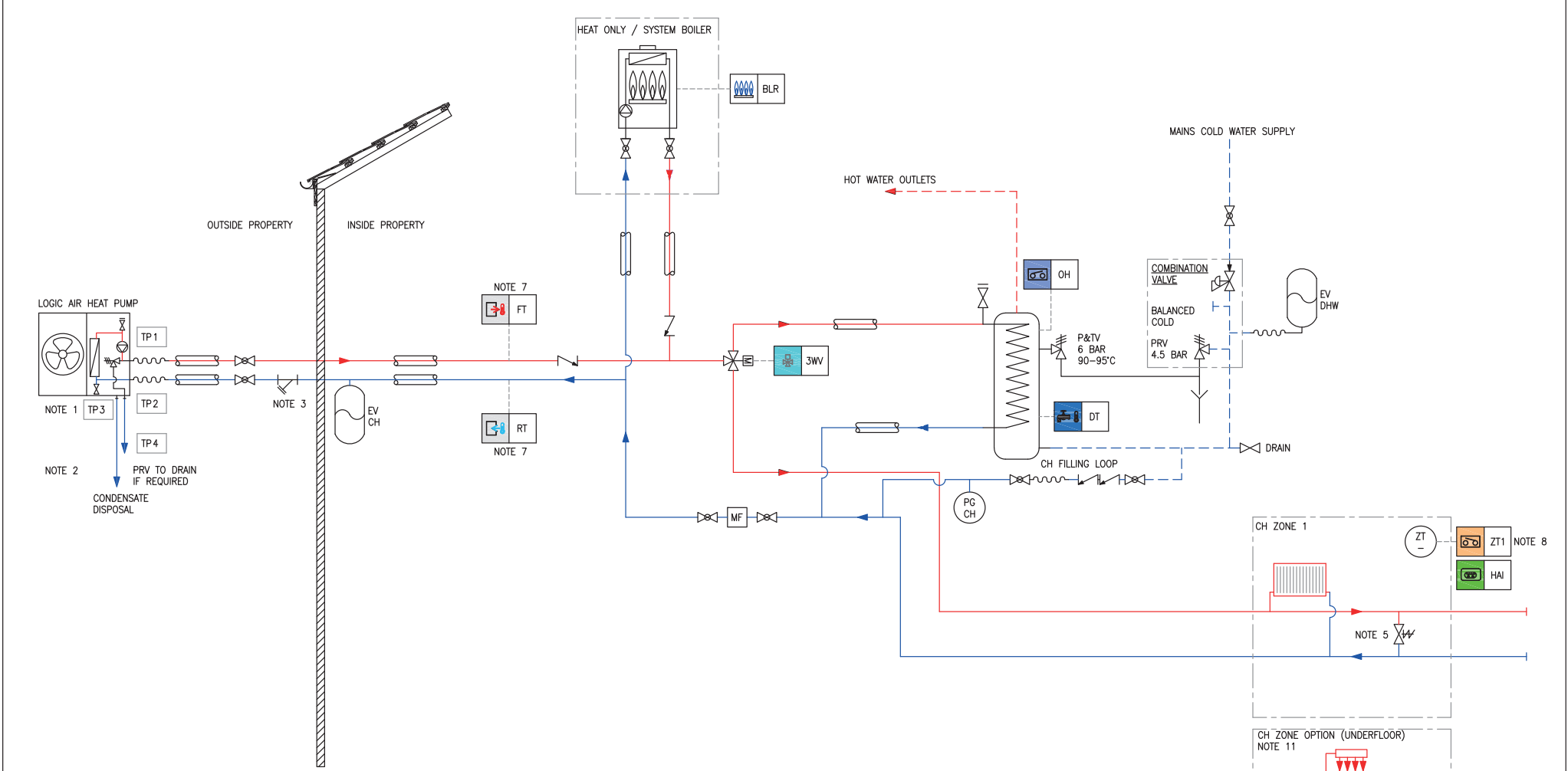

- Notes.**
- Note 1. The heat pump must be installed on a secure level base capable of supporting its weight.
 - Note 2. Refer to the installation manual for condensate and pressure relief discharge requirements.
 - Note 3. A particulate filter is required and can be supplied as an option. A magnetic filter is recommended.
 - Note 4. Glycol is required for antifreeze protection on all hybrid systems.
 - Note 5. Install an auto-bypass if no permanent open circuit is available to allow secondary side pump overrun and normal operation.
 - Note 6. Boiler flow temperature must be set to 65°C to achieve DHW legionella temperature.
 - Note 7. Flow and return pipe clip-on sensors must be installed on the 28mm copper pipe work.
 - Note 8. Refer to the installation manual for smart or ON/OFF thermostat connection.
 - Note 9. Boiler pump must be positioned on the return or in the case of a heat only boiler, an additional pump must be fitted to the boiler return.
 - Note 10. Ensure the correct pipe size is installed. Refer to the Logic Air heat pump and boiler installation manuals.
 - Note 11. Underfloor heating circuit option. Refer to the manufacturers installation instructions for pump and bypass requirements.

This drawing is for information and guidance only. It is the heating designer/ installers responsibility to adhere to the latest relevant standards.
 Refer to Logic Air monobloc heatpump system installation and maintenance manual in conjunction with these schematic drawings.

CONNECTION POINT LIST				
TP No	DESCRIPTION	SIZE	MATERIAL	TYPE
1	HEAT PUMP FLOW	1" BSP	BRASS	BSP MALE
2	HEAT PUMP RETURN	1" BSP	BRASS	BSP MALE
3	HEAT PUMP CONDENSATE DISPOSAL	-	-	-
4	PRESSURE RELIEF VALVE (PRV)	15MM	COPPER	COPPER PIPE OUTLET

Figure 17. Logic Air + Heat Only Boiler Backup + Buffer with Two Zones

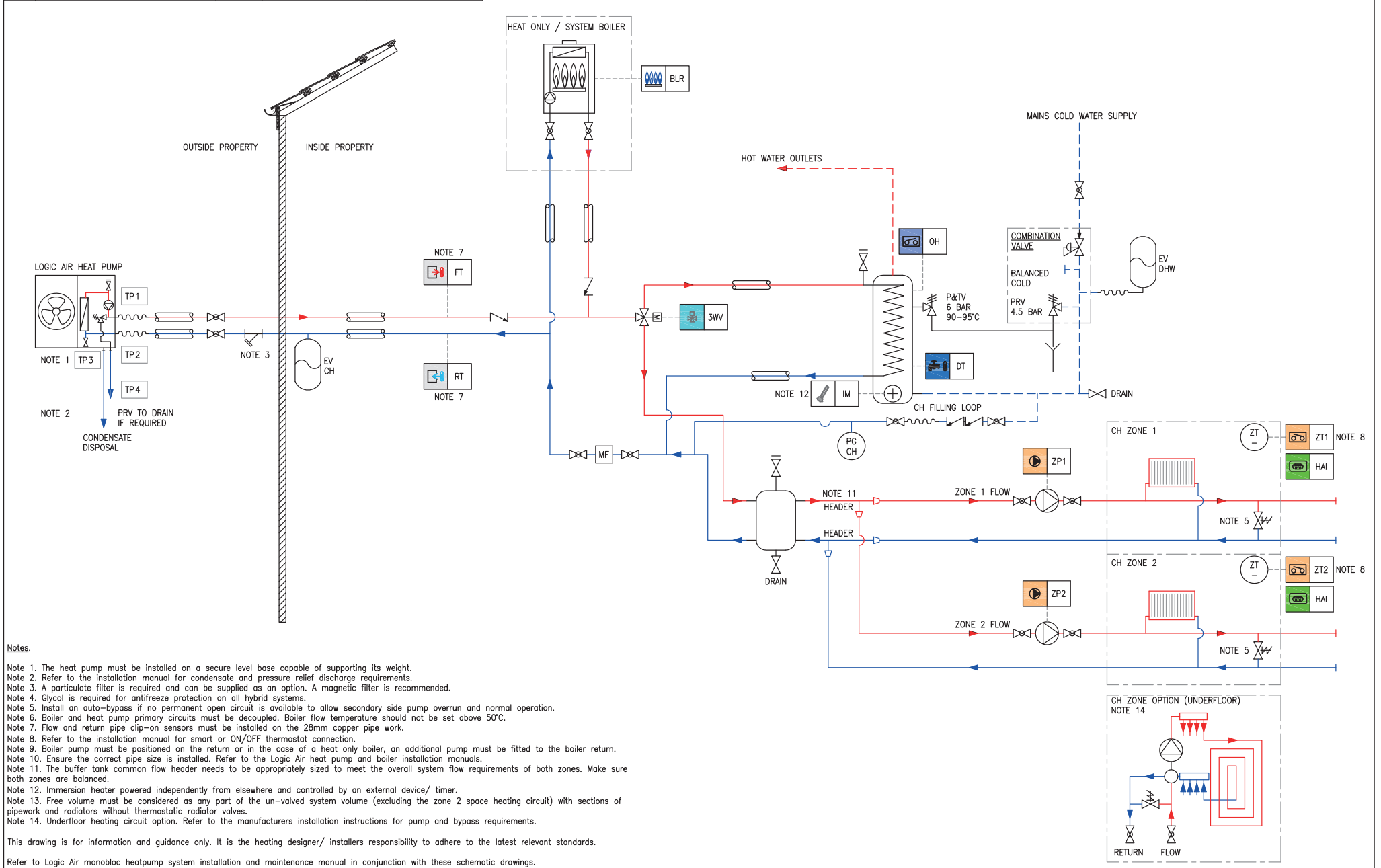

Notes.

- Note 1. The heat pump must be installed on a secure level base capable of supporting its weight.
- Note 2. Refer to the installation manual for condensate and pressure relief discharge requirements.
- Note 3. A particulate filter is required and can be supplied as an option. A magnetic filter is recommended.
- Note 4. Glycol is required for antifreeze protection on all hybrid systems.
- Note 5. Install an auto-bypass if no permanent open circuit is available to allow secondary side pump overrun and normal operation.
- Note 6. Boiler and heat pump primary circuits must be decoupled. Boiler flow temperature should not be set above 50°C.
- Note 7. Flow and return pipe clip-on sensors must be installed on the 28mm copper pipe work.
- Note 8. Refer to the installation manual for smart or ON/OFF thermostat connection.
- Note 9. Boiler pump must be positioned on the return or in the case of a heat only boiler, an additional pump must be fitted to the boiler return.
- Note 10. Ensure the correct pipe size is installed. Refer to the Logic Air heat pump and boiler installation manuals.
- Note 11. The buffer tank common flow header needs to be appropriately sized to meet the overall system flow requirements of both zones. Make sure both zones are balanced.
- Note 12. Immersion heater powered independently from elsewhere and controlled by an external device/ timer.
- Note 13. Free volume must be considered as any part of the un-valved system volume (excluding the zone 2 space heating circuit) with sections of pipework and radiators without thermostatic radiator valves.
- Note 14. Underfloor heating circuit option. Refer to the manufacturers installation instructions for pump and bypass requirements.

This drawing is for information and guidance only. It is the heating designer/ installers responsibility to adhere to the latest relevant standards.

Refer to Logic Air monobloc heatpump system installation and maintenance manual in conjunction with these schematic drawings.

CONNECTION POINT LIST				
TP No	DESCRIPTION	SIZE	MATERIAL	TYPE
1	HEAT PUMP FLOW	1" BSP	BRASS	BSP MALE
2	HEAT PUMP RETURN	1" BSP	BRASS	BSP MALE
3	HEAT PUMP CONDENSATE DISPOSAL	-	-	-
4	PRESSURE RELIEF VALVE (PRV)	15MM	COPPER	COPPER PIPE OUTLET
5	CYLINDER HEAT PUMP FLOW	28MM	BRASS	COMPRESSION
6	CYLINDER HEAT PUMP RETURN	28MM	BRASS	COMPRESSION
7	ZONE 1 FLOW	28MM	BRASS	COMPRESSION
8	ZONE 1 RETURN	28MM	BRASS	COMPRESSION
9	ZONE 2 FLOW	28MM	BRASS	COMPRESSION
10	ZONE 2 RETURN	28MM	BRASS	COMPRESSION

Figure 18. Logic Air + System Boiler + Two Zone Pre-Plumbed Cylinder with Integrated Buffer

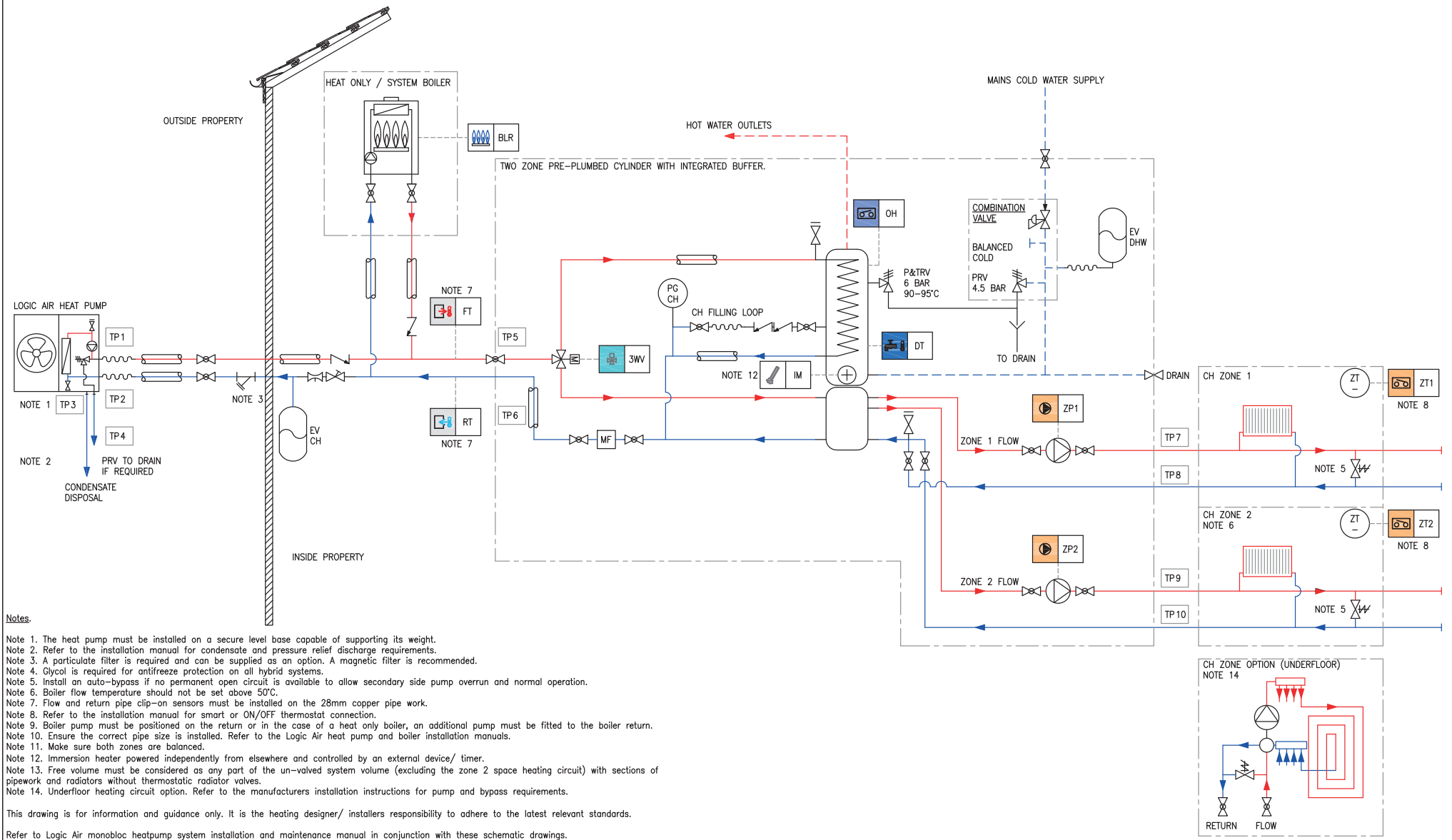

- Notes.**
- Note 1. The heat pump must be installed on a secure level base capable of supporting its weight.
 - Note 2. Refer to the installation manual for condensate and pressure relief discharge requirements.
 - Note 3. A particulate filter is required and can be supplied as an option. A magnetic filter is recommended.
 - Note 4. Glycol is required for antifreeze protection on all hybrid systems.
 - Note 5. Install an auto-bypass if no permanent open circuit is available to allow secondary side pump overrun and normal operation.
 - Note 6. Boiler flow temperature should not be set above 50°C.
 - Note 7. Flow and return pipe clip-on sensors must be installed on the 28mm copper pipe work.
 - Note 8. Refer to the installation manual for smart or ON/OFF thermostat connection.
 - Note 9. Boiler pump must be positioned on the return or in the case of a heat only boiler, an additional pump must be fitted to the boiler return.
 - Note 10. Ensure the correct pipe size is installed. Refer to the Logic Air heat pump and boiler installation manuals.
 - Note 11. Make sure both zones are balanced.
 - Note 12. Immersion heater powered independently from elsewhere and controlled by an external device/ timer.
 - Note 13. Free volume must be considered as any part of the un-valved system volume (excluding the zone 2 space heating circuit) with sections of pipework and radiators without thermostatic radiator valves.
 - Note 14. Underfloor heating circuit option. Refer to the manufacturers installation instructions for pump and bypass requirements.
- This drawing is for information and guidance only. It is the heating designer/ installers responsibility to adhere to the latest relevant standards.
Refer to Logic Air monobloc heatpump system installation and maintenance manual in conjunction with these schematic drawings.

Figure 19. Hydraulically Separated Logic Air + System Boiler + DHW + Two Zones (Bivalent System)

CONNECTION POINT LIST				
TP No	DESCRIPTION	SIZE	MATERIAL	TYPE
1	HEAT PUMP FLOW	1" BSP	BRASS	BSP MALE
2	HEAT PUMP RETURN	1" BSP	BRASS	BSP MALE
3	HEAT PUMP CONDENSATE DISPOSAL	-	-	-
4	PRESSURE RELIEF VALVE (PRV)	15MM	COPPER	COPPER PIPE OUTLET

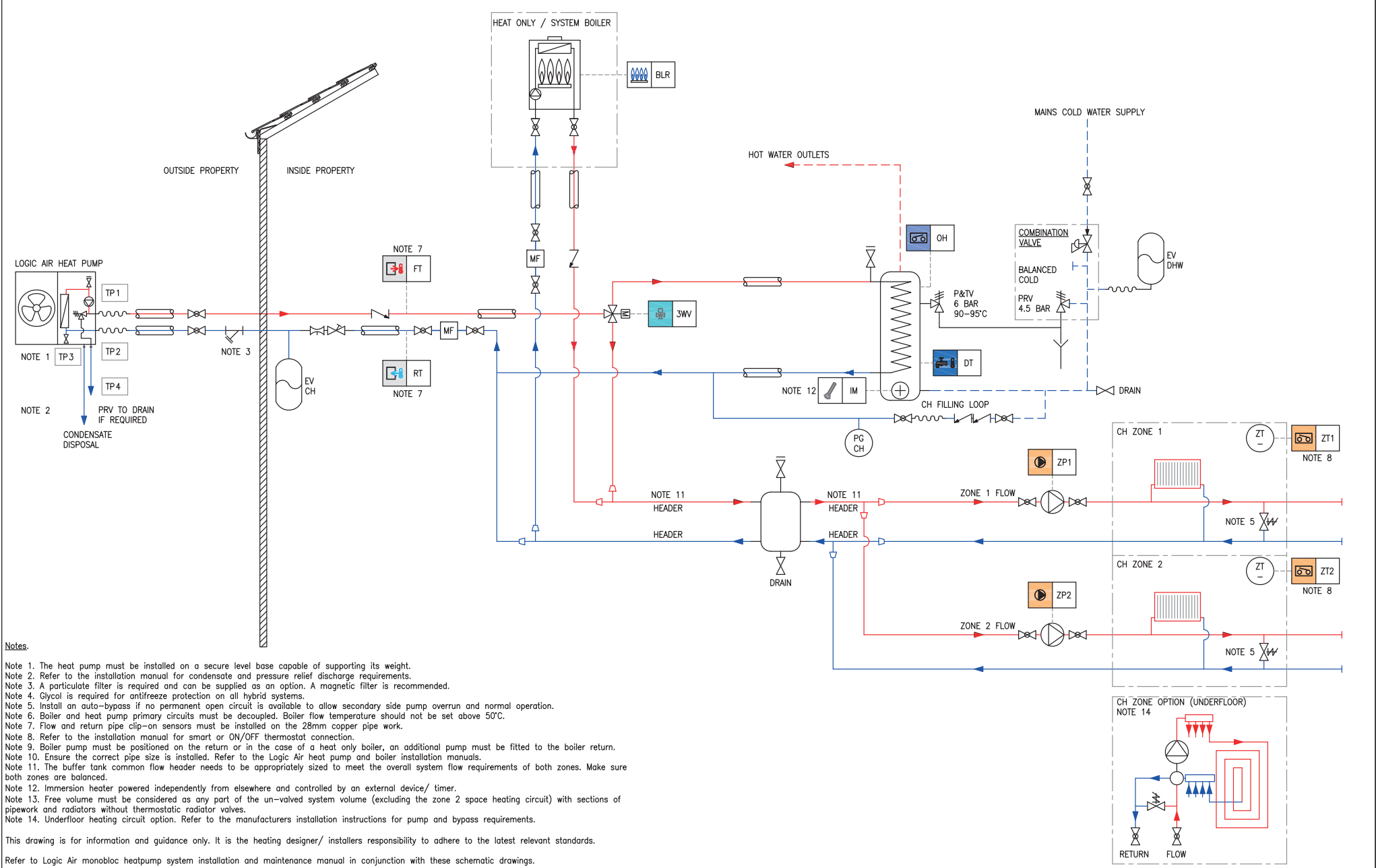

- Notes.**
- Note 1. The heat pump must be installed on a secure level base capable of supporting its weight.
 - Note 2. Refer to the installation manual for condensate and pressure relief discharge requirements.
 - Note 3. A particulate filter is required and can be supplied as an option. A magnetic filter is recommended.
 - Note 4. Glycol is required for antifreeze protection on all hybrid systems.
 - Note 5. Install an auto-bypass if no permanent open circuit is available to allow secondary side pump overrun and normal operation.
 - Note 6. Boiler and heat pump primary circuits must be decoupled. Boiler flow temperature should not be set above 50°C.
 - Note 7. Flow and return pipe clip-on sensors must be installed on the 28mm copper pipe work.
 - Note 8. Refer to the installation manual for smart or ON/OFF thermostat connection.
 - Note 9. Boiler pump must be positioned on the return or in the case of a heat only boiler, an additional pump must be fitted to the boiler return.
 - Note 10. Ensure the correct pipe size is installed. Refer to the Logic Air heat pump and boiler installation manuals.
 - Note 11. The buffer tank common flow header needs to be appropriately sized to meet the overall system flow requirements of both zones. Make sure both zones are balanced.
 - Note 12. Immersion heater powered independently from elsewhere and controlled by an external device/ timer.
 - Note 13. Free volume must be considered as any part of the un-valved system volume (excluding the zone 2 space heating circuit) with sections of pipework and radiators without thermostatic radiator valves.
 - Note 14. Underfloor heating circuit option. Refer to the manufacturers installation instructions for pump and bypass requirements.
- This drawing is for information and guidance only. It is the heating designer/ installers responsibility to adhere to the latest relevant standards.
Refer to Logic Air monobloc heatpump system installation and maintenance manual in conjunction with these schematic drawings.

CONNECTION POINT LIST				HEADER SIZE GUIDE		
TP No	DESCRIPTION	SIZE	MATERIAL	TYPE	LOGIC AIR HEAT PUMP	HEADER SIZE (mm)
1	HEAT PUMP FLOW	1" BSP	BRASS	BSP MALE	2 x 4kW	28 OD (26.2 ID)
2	HEAT PUMP RETURN	1" BSP	BRASS	BSP MALE	2 x 5kW	28 OD (26.2 ID)
3	HEAT PUMP CONDENSATE DISPOSAL	-	-	-	2 x 8kW	35 OD (32.6 ID)
4	PRESSURE RELIEF VALVE (PRV)	15MM	COPPER	COPPER PIPE OUTLET	2 x 10kW	42 OD (39.6 ID)

Figure 20. Logic Air Monobloc Cascade Heat Only, Decoupler with Two Zones

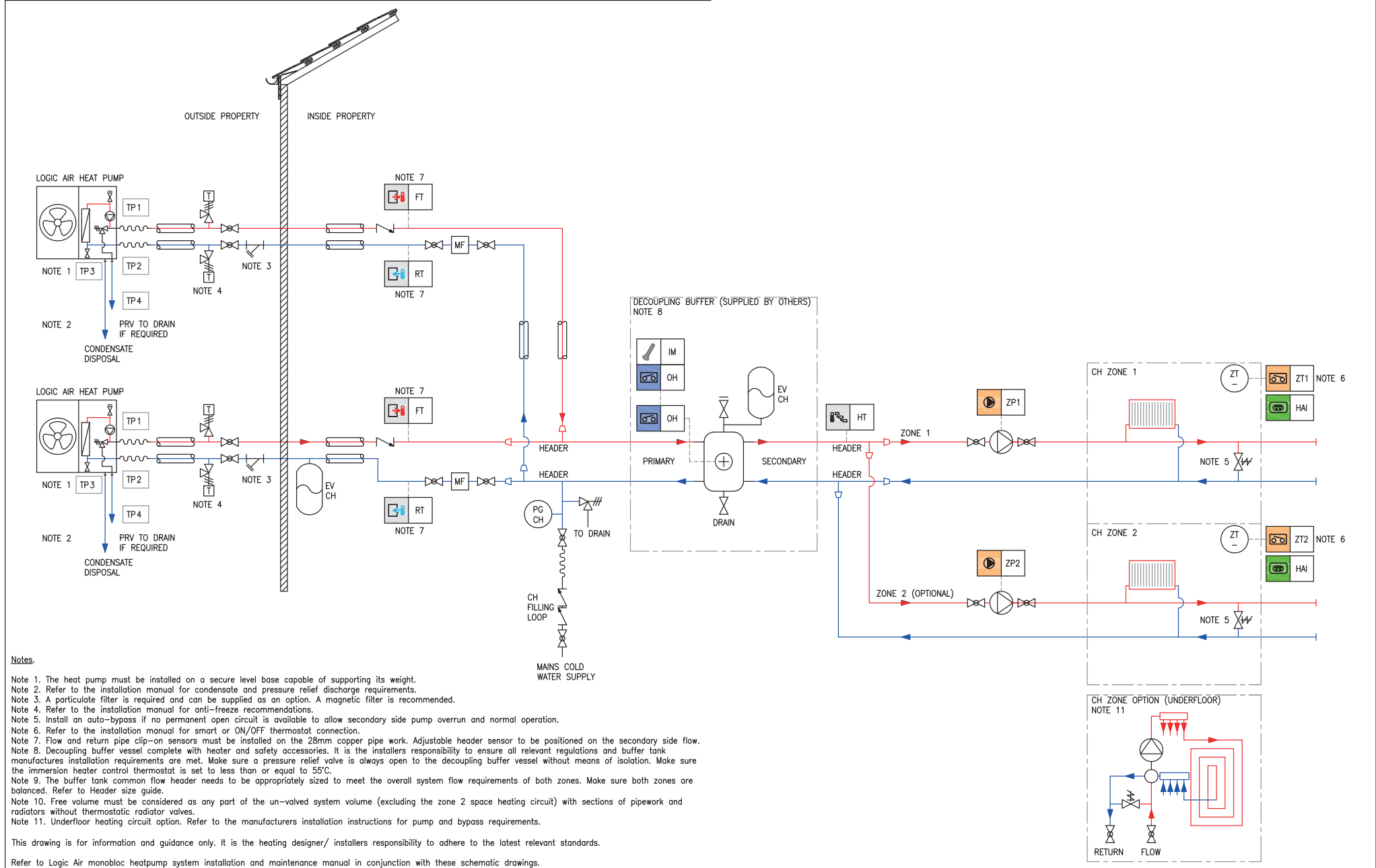

CONNECTION POINT LIST				HEADER SIZE GUIDE		
TP No	DESCRIPTION	SIZE	MATERIAL	TYPE	LOGIC AIR HEAT PUMP	HEADER SIZE (mm)
1	HEAT PUMP FLOW	1" BSP	BRASS	BSP MALE	2 x 4kW	28 OD (26.2 ID)
2	HEAT PUMP RETURN	1" BSP	BRASS	BSP MALE	2 x 5kW	28 OD (26.2 ID)
3	HEAT PUMP CONDENSATE DISPOSAL	-	-	-	2 x 8kW	35 OD (32.6 ID)
4	PRESSURE RELIEF VALVE (PRV)	15MM	COPPER	COPPER PIPE OUTLET	2 x 10kW	42 OD (39.6 ID)

Figure 21. Logic Air Monobloc Cascade, Third Party DHW Cylinder, Decoupler with Two Zones

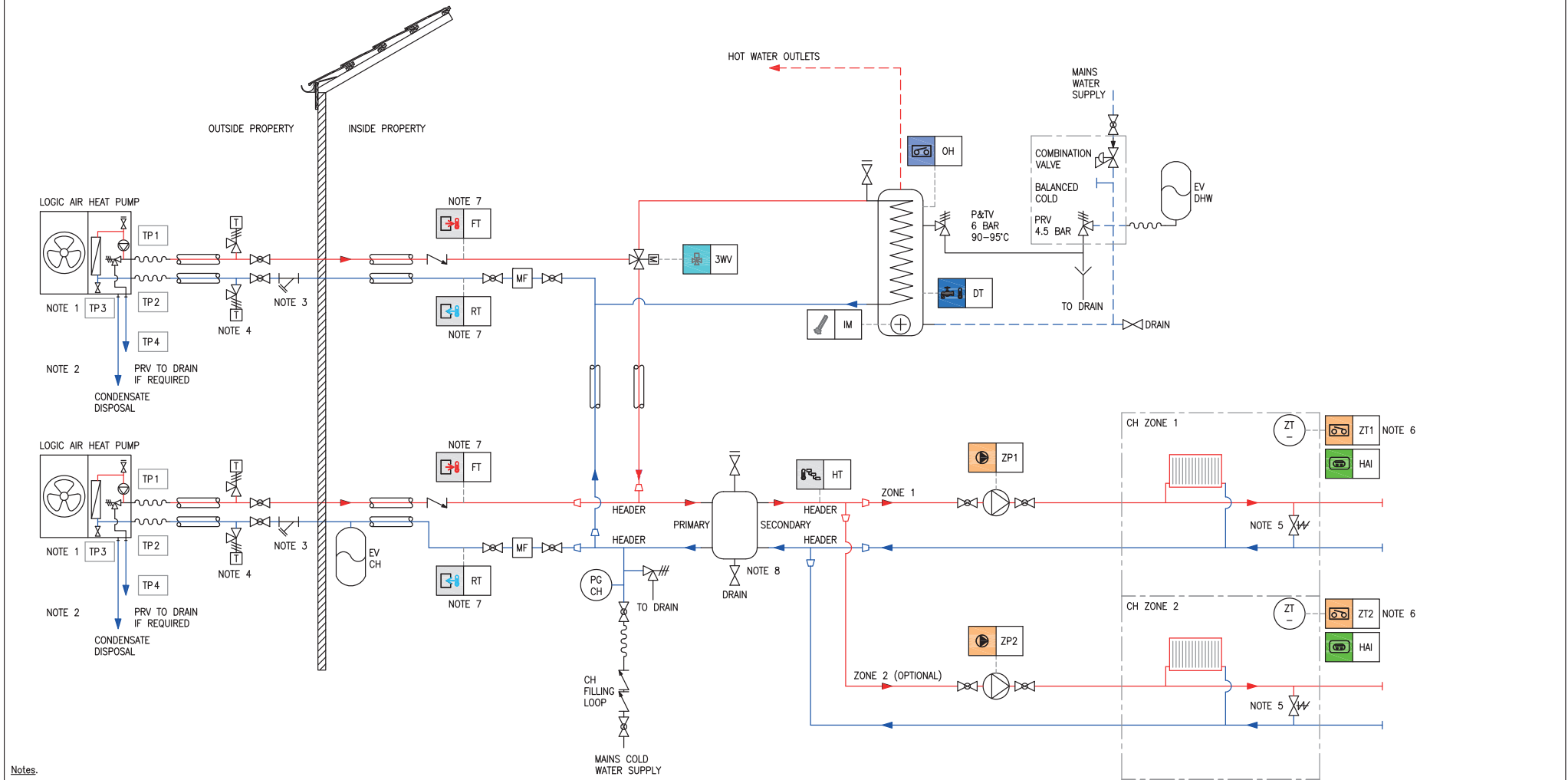

- Notes:**
- Note 1. The heat pump must be installed on a secure level base capable of supporting its weight.
 - Note 2. Refer to the installation manual for condensate and pressure relief discharge requirements.
 - Note 3. A particulate filter is required and can be supplied as an option. A magnetic filter is recommended.
 - Note 4. Refer to the installation manual for anti-freeze recommendations.
 - Note 5. Install an auto-bypass if no permanent open circuit is available to allow secondary side pump overrun and normal operation.
 - Note 6. Refer to the installation manual for smart or ON/OFF thermostat connection.
 - Note 7. Flow and return pipe clip-on sensors must be installed on the 28mm copper pipe work. Adjustable header sensor to be positioned on the secondary side flow.
 - Note 8. Buffer vessel (Hydraulic decoupler).
 - Note 9. The hydraulic decoupler common flow header needs to be appropriately sized to meet the overall system flow requirements of both zones. Make sure both zones are balanced. Refer to Header size guide.
 - Note 10. Free volume must be considered as any part of the un-valved system volume (excluding the zone 2 space heating circuit) with sections of pipework and radiators without thermostatic radiator valves.
 - Note 11. Underfloor heating circuit option. Refer to the manufacturers installation instructions for pump and bypass requirements.
- This drawing is for information and guidance only. It is the heating designer/ installers responsibility to adhere to the latest relevant standards.
Refer to Logic Air monobloc heatpump system installation and maintenance manual in conjunction with these schematic drawings.

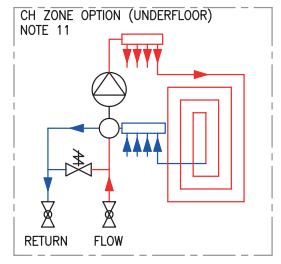

CONNECTION POINT LIST				
TP No	DESCRIPTION	SIZE	MATERIAL	TYPE
1	HEAT PUMP FLOW	1" BSP	BRASS	BSP MALE
2	HEAT PUMP RETURN	1" BSP	BRASS	BSP MALE
3	HEAT PUMP CONDENSATE DISPOSAL	-	-	-
4	PRESSURE RELIEF VALVE (PRV)	15MM	COPPER	COPPER PIPE OUTLET

Figure 22. Logic Air Monobloc Cascade + Third Party DHW Cylinder + Multi-Port Decoupler with Two Zones

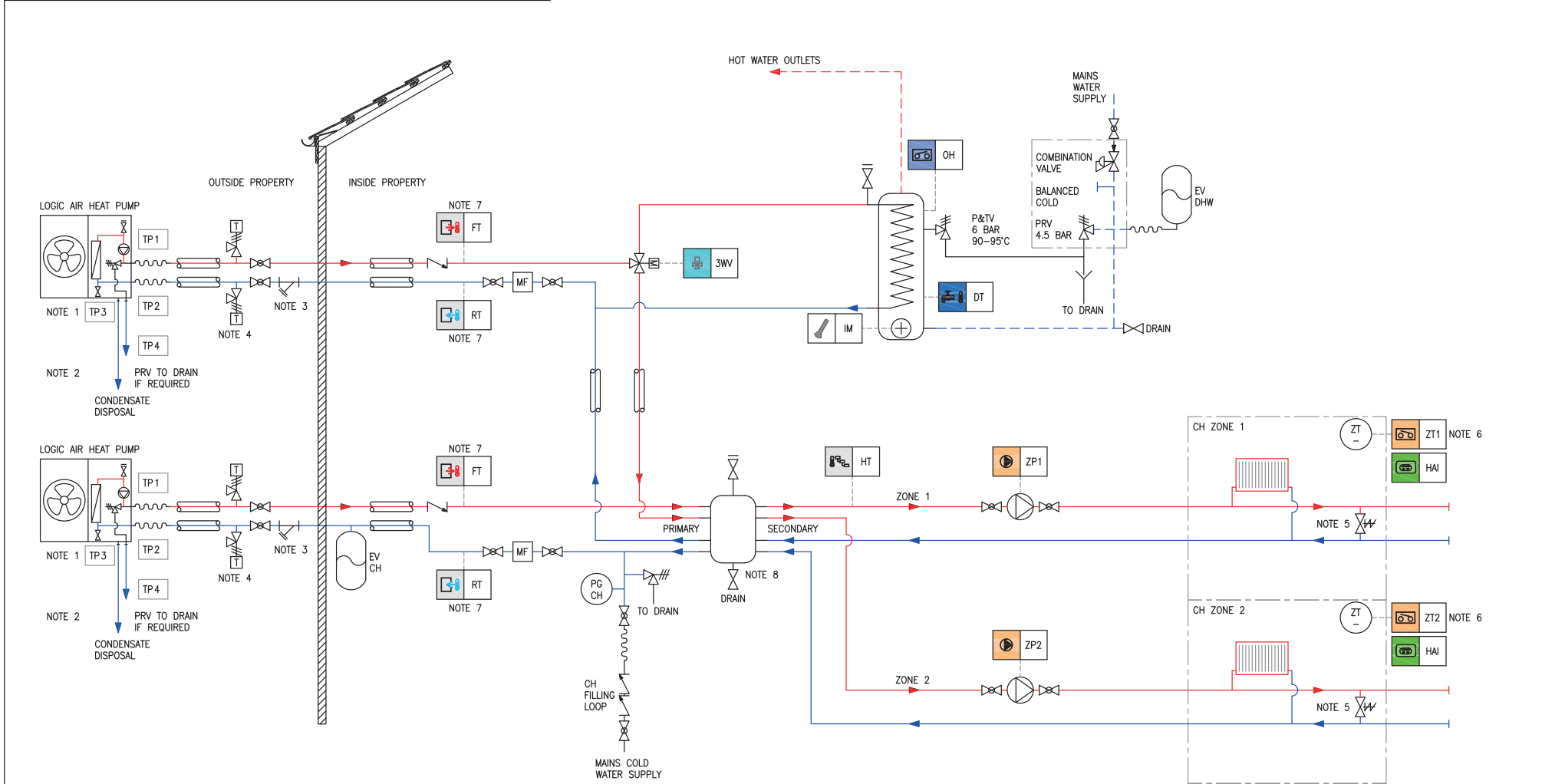

Notes.

- Note 1. The heat pump must be installed on a secure level base capable of supporting its weight.
- Note 2. Refer to the installation manual for condensate and pressure relief discharge requirements.
- Note 3. A particulate filter is required and can be supplied as an option. A magnetic filter is recommended.
- Note 4. Refer to the installation manual for anti-freeze recommendations.
- Note 5. Install an auto-bypass if no permanent open circuit is available to allow secondary side pump overrun and normal operation.
- Note 6. Refer to the installation manual for smart or ON/OFF thermostat connection.
- Note 7. Flow and return pipe clip-on sensors must be installed on the 26mm copper pipe work. Adjustable header sensor to be positioned on the secondary side flow.
- Note 8. The decoupling buffer vessel needs to be appropriately sized to meet the overall system flow requirements of both zones. Make sure both zones are balanced.
- Note 9. Free volume must be considered as any part of the un-valved system volume (excluding the zone 2 space heating circuit) with sections of pipework and radiators without thermostatic radiator valves.
- Note 10. Underfloor heating circuit option. Refer to the manufacturers installation instructions for pump and bypass requirements.

This drawing is for information and guidance only. It is the heating designer/ installers responsibility to adhere to the latest relevant standards.

Refer to Logic Air monobloc heatpump system installation and maintenance manual in conjunction with these schematic drawings.

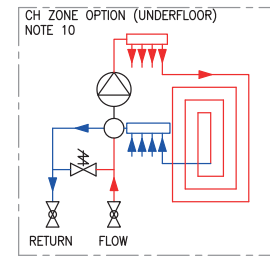

CONNECTION POINT LIST				
TP No	DESCRIPTION	SIZE	MATERIAL	TYPE
1	HEAT PUMP FLOW	1" BSP	BRASS	BSP MALE
2	HEAT PUMP RETURN	1" BSP	BRASS	BSP MALE
3	HEAT PUMP CONDENSATE DISPOSAL	-	-	-
4	PRESSURE RELIEF VALVE (PRV)	15MM	COPPER	COPPER PIPE OUTLET

Figure 23. Logic Air Monobloc Cascade Heat Only + Multi-Port Decoupler with Two Zones

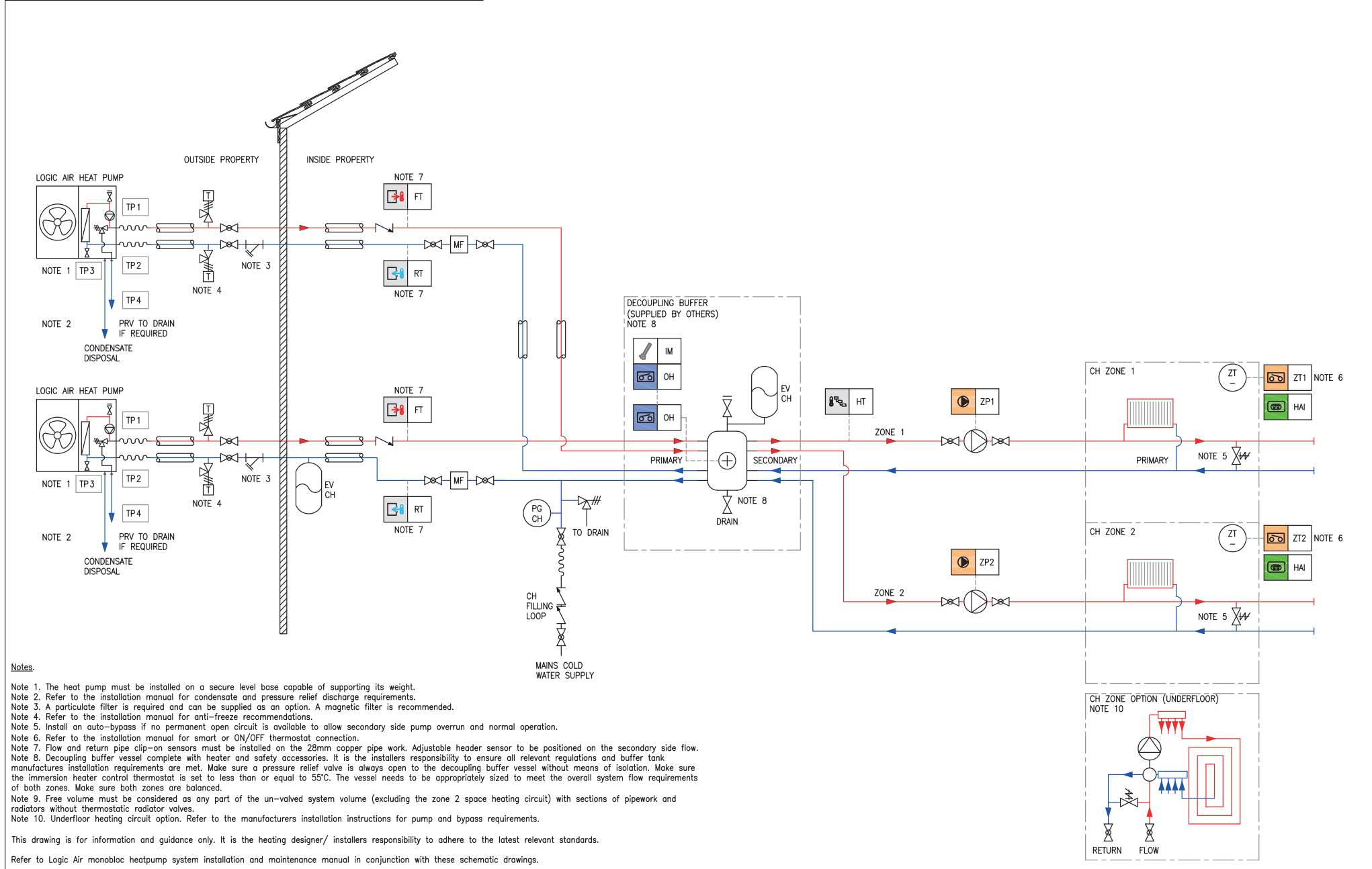

Notes.

- Note 1. The heat pump must be installed on a secure level base capable of supporting its weight.
- Note 2. Refer to the installation manual for condensate and pressure relief discharge requirements.
- Note 3. A particulate filter is required and can be supplied as an option. A magnetic filter is recommended.
- Note 4. Refer to the installation manual for anti-freeze recommendations.
- Note 5. Install an auto-bypass if no permanent open circuit is available to allow secondary side pump overrun and normal operation.
- Note 6. Refer to the installation manual for smart or ON/OFF thermostat connection.
- Note 7. Flow and return pipe clip-on sensors must be installed on the 28mm copper pipe work. Adjustable header sensor to be positioned on the secondary side flow.
- Note 8. Decoupling buffer vessel complete with heater and safety accessories. It is the installers responsibility to ensure all relevant regulations and buffer tank manufactures installation requirements are met. Make sure the immersion heater control thermostat is set to less than or equal to 55°C. The vessel needs to be appropriately sized to meet the overall system flow requirements of both zones. Make sure both zones are balanced.
- Note 9. Free volume must be considered as any part of the un-valved system volume (excluding the zone 2 space heating circuit) with sections of pipework and radiators without thermostatic radiator valves.
- Note 10. Underfloor heating circuit option. Refer to the manufacturers installation instructions for pump and bypass requirements.

This drawing is for information and guidance only. It is the heating designer/ installers responsibility to adhere to the latest relevant standards.

Refer to Logic Air monobloc heatpump system installation and maintenance manual in conjunction with these schematic drawings.

At Ideal Heating we take our environmental impact seriously, therefore when installing any Ideal Heating product please make sure to dispose of any previous appliance in an environmentally conscious manner. Households can contact their local authority to find out how. See <https://www.gov.uk/managing-your-waste-an-overview> for guidance on how to efficiently recycle your business waste.



Technical Training

Our Expert Academy offer a range of training options designed and delivered by our experts in heating. For details please contact: expert-academy.co.uk

Ideal Boilers Ltd., pursues a policy of continuing improvement in the design and performance of its products. The right is therefore reserved to vary specification without notice.

Ideal is a trademark of Ideal Boilers.

Registered Office

Ideal Boilers Ltd., National Avenue, Hull, East Yorkshire, HU5 4JB

Tel 01482 492251 Fax 01482 448858

Registration No. London 322 137

EU Authorised Representative:

Atlantic SFDT

44 Boulevard des Etats-Unis, 85 000 La Roche-Sur-Yon, France

+33 (0)2 51 44 34 34

Ideal Technical Helpline: 01482 498663

Ideal Consumer Helpline: 01482 498660

Ideal Parts: 01482 498665

idealheating.com

ideal
HEATING